

FEBAMETAL

GRAF[®]
WERKZEUGSYSTEME

HOCHLEISTUNGSWERKZEUGE FÜR DREHTECHNIK

HIGH-PERFORMANCE TOOLS FOR TURNING TECHNOLOGY

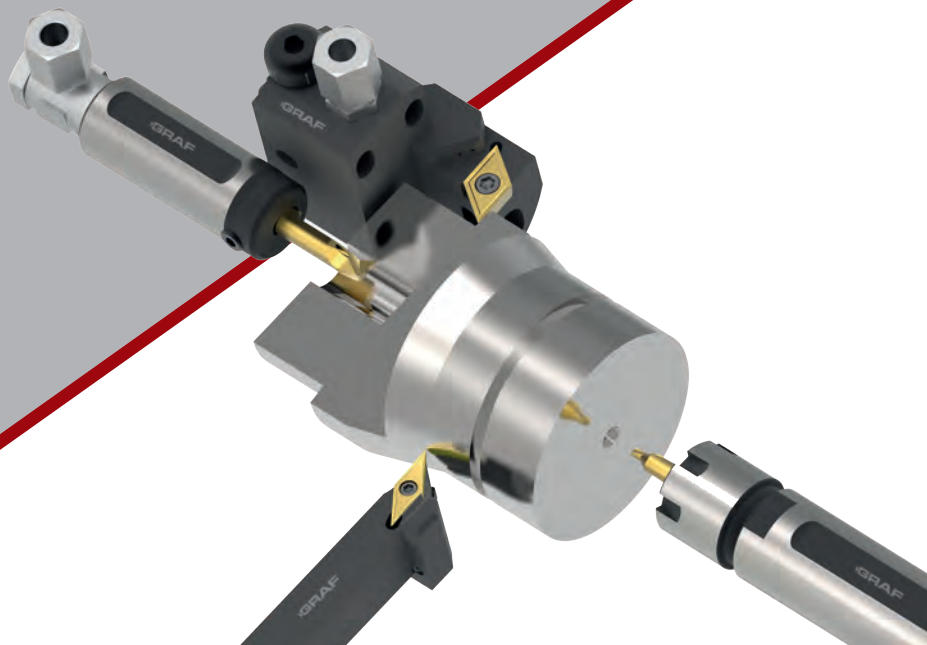

GRAF 2021/2022

Reduzierte Standzeiten

Kühlmittelezufuhr

Wendeplattenhalter

Langdrehautomaten

Schneidplatten

Hochleistungswerkzeuge

Höhenverstellbare Rückseitenwerkzeuge

Kühlmittelanschluss

Rundschaftwerkzeuge

Drehhalter

Spannmutter

Fräsdorne

Reduzierhülsen

Schnellwechselsystem

Reduced service life

Cooling supply

Insert holder

Swiss type machines

High Performance Tools

Inserts

Height-adjustable back working tools

Coolant Routing

Round Shank Tools

Turning holder

Milling Arbors

Reducing sleeves

Clamping nut

Quick change system

Kapitel 1 / Chapter 1

Wendeplattenhalter /
Turret Plate holder

1.00 – 1.57



1

Kapitel 2 / Chapter 2

Hartmetall-Wendeschneidplatten /
Hard Metal Inserts

2.1 – 2.21

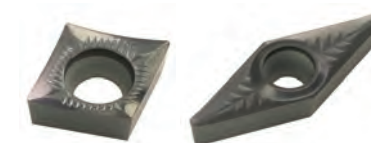

2

Kapitel 3 / Chapter 3

Höhenverstellbare Rückseitenbearbeitungs-Werkzeuge /
Height Adjustable Back Working Tools

3.1 – 3.141



3

Kapitel 4 / Chapter 4

Rundschaft-Werkzeuge /
Round Shank Tools

4.1 – 4.87



4

Kapitel 5 / Chapter 5

Kühlmittelführung /
Cooling Routing

5.1 – 5.10



5

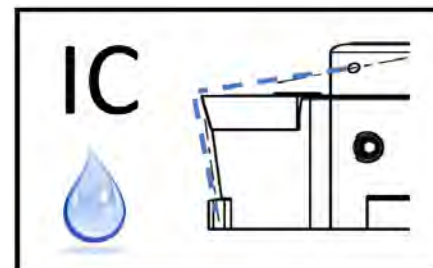

**Wendeplattenhalter
mit Innenkühlung von oben und unten**

turret plate holder with coolant supply
from above and below

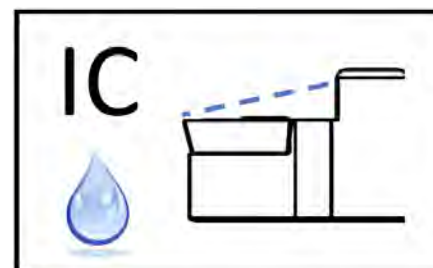

**Wendeplattenhalter
mit Innenkühlung von oben**

turret plate holder with coolant supply
from above

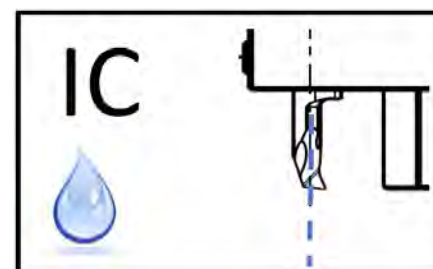

**Wendeplattenhalter
mit Innenkühlung durch die Platte**

turret plate holder with coolant supply
through the insert

INHALTSVERZEICHNIS
SUMMARY

Wendeplattenhalter für GRAF G Wendeplatten Turret plate holder for GRAF G insert	1.8
Wendeplattenhalter für WN..06 04.. Wendeplatten Turret plate holder for WN..06 04..insert	1.12
Wendeplattenhalter für DC.. Wendeplatten Turret plate holder for DC.. insert	1.13
Wendeplattenhalter für YW.. Wendeplatten Turret plate holder for YW.. insert	1.23
Wendeplattenhalter für CC.. Wendeplatten Turret plate holder for CC.. insert	1.24
Wendeplattenhalter für VC.. Wendeplatten Turret plate holder for VC.. insert	1.26
Wendeplattenhalter für VB.. Wendeplatten Turret plate holder for VB.. insert	1.35
Wendeplattenhalter für HORN Schneidplatten Typ 105 Turret plate holder for HORN insert type 105	1.37
Wendeplattenhalter für HORN Schneidplatten Typ 312 Turret plate holder for HORN insert type 312	1.40
Wendeplattenhalter für HORN Schneidplatten Typ S 274 Turret plate holder for HORN insert type S 274	1.41
Wendeplattenhalter für HORN Schneidplatten Typ 105 und S 274 Turret plate holder for HORN insert type 105 and S 274	1.42
Wendeplattenhalter für HORN Schneidplatten Typ S 100 Turret plate holder for HORN insert type S 100	1.43

INHALTSVERZEICHNIS
SUMMARY

Wendeplattenhalter für Precitool Typ 615 Turret plate holder for Precitool type 615	1.46
Wendeplattenhalter für NKT.. Wendeplatten Turret plate holder for NKT.. insert	1.47
Wendeplattenhalter für ER16/16EL Wendeplatten Turret plate holder for ER16/EL16 insert	1.48
Wendeplattenhalter für CS.. Wendeplatten Turret plate holder for CS.. insert	1.50
Wendeplattenhalter für CoroCut Wendeplatten Turret plate holder for CoroCut insert	1.52
Rändel-Werkzeuge Knurling tools	1.53
Bohr- und Ausdreh-Werkzeuge Boring tools	1.55
Zentrierbohrerhalter Center boring holder	1.56

Wendeplattenhalter Typ GRAF G-Platte
Turret plate holder type GRAF G-insert

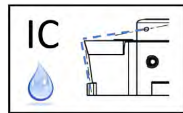

Anwendungsbereich Abstechen, Einstech-Langdrehen
Range of application plunging, grooving

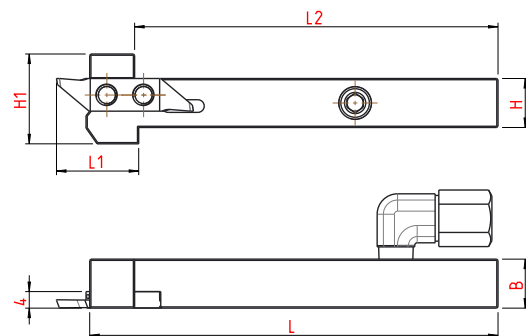

Bestell Nummer Order Number	Bezeichnung Description	L	B	H	L1	L2	H1	für Wendeplatte for insert
01-1365	G.101.R.2IK	100	12	10	20	89	20	für alle Graf G-Wendeplatten for all GRAF G-insert
01-1366	G.101.L.2IK	100	12	10	20	89	20	
01-1367	G.121.R.2IK	100	12	12	20	89	22	
01-1368	G.121.L.2IK	100	12	12	20	89	22	
01-1369	G.161.R.2IK	100	16	16	20	89	26	
01-1370	G.161.L.2IK	100	16	16	20	89	26	

Abmessungen in mm
Dimensions in mm

Wendeplatten siehe 2.2-2.7
insert see page 2.2-2.7

Ersatzteile / Spare parts	
004.00.22	001.01.12

Weitere Größen auf Anfrage
other sizes on request

Wendeplattenhalter Typ GRAF G-Platte
Turret plate holder type GRAF G-insert

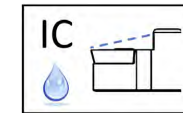

Anwendungsbereich Abstechen, Einstech-Langdrehen
Range of application plunging, grooving

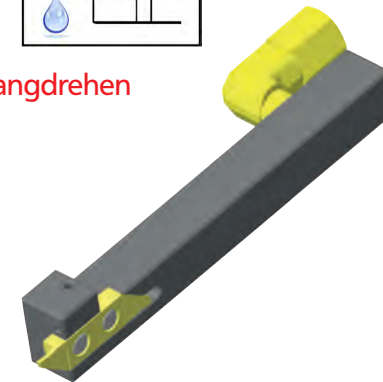
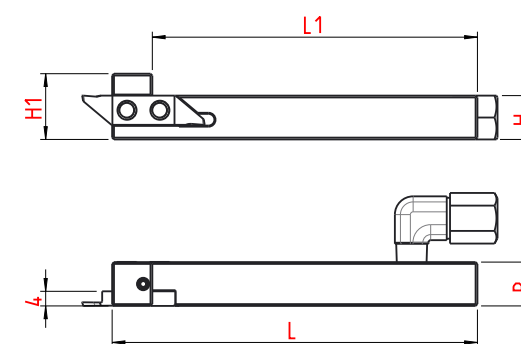

Bestell Nummer Order Number	Bezeichnung Description	L	L1	B	H	H1	für Wendeplatte for insert
14-0350	G.101.R.IK	100	89	10	12	16	für alle GRAF G-Wendeplatten for all GRAF G-insert
14-0351	G.101.L.IK	100	89	10	12	16	
14-0324	G.121.R.IK	100	89	12	12	18	
14-0346	G.121.L.IK	100	89	12	12	18	
14-0325	G.161.R.IK	100	89	16	16	22	
14-0347	G.161.L.IK	100	89	16	16	22	

Abmessungen in mm
Dimensions in mm

Wendeplatten siehe Seite 2.2 – 2.7
insert see page 2.2 – 2.7

Ersatzteile / Spare parts	
004.00.22	001.01.12

Weitere Größen auf Anfrage
other sizes on request

Wendepplattenhalter Typ GRAF G-Platte
Turret plate holder type GRAF G-insert

Anwendungsbereich Abstechen, Einstech-Langdrehen
Range of application plunging, grooving



Bestell Nummer Order Number	Bezeichnung Description	L	B	H	für Wendepplatte for insert
14-0266	G.101.R	125	10	10	für alle GRAF G-Wendepplatten for all GRAF G-insert
14-0268	G.101.L	125	10	10	
14-0267	G.121.R	125	12	12	
14-0273	G.121.L	125	12	12	
14-0269	G.161.R	125	16	16	
14-0274	G.161.L	125	16	16	

Abmessungen in mm
Dimensions in mm

Wendepplatten siehe Seite 2.2 – 2.7
insert see page 2.2 – 2.7

Ersatzteile / Spare parts

001.01.12

Weitere Größen auf Anfrage
other sizes on request

Wendepplattenhalter Typ GRAF G-Platte
Turret plate holder type GRAF G-insert

Anwendungsbereich Abstechen, Einstech-Langdrehen
Range of application plunging, grooving



Bestell Nummer Order Number	Bezeichnung Description	L	B	H	für Wendepplatte for insert
14-0278	G.106.R	125	10	10	für GRAF G-Wendepplatten G 0006.0 for all GRAF G 0006.0 G-insert
14-0279	G.106.L	125	10	10	
14-0314	G.126.R	125	12	12	
14-0313	G.126.L	125	12	12	
14-0316	G.166.R	125	16	16	
14-0315	G.166.L	125	16	16	

Abmessungen in mm
Dimensions in mm

Wendepplatten siehe Seite 2.2 – 2.7
insert see page 2.2 – 2.7

Ersatzteile / Spare parts

001.01.12

Weitere Größen auf Anfrage
other sizes on request

Wendepplattenhalter Typ WN..Platte
Turret plate holder type WN.. insert

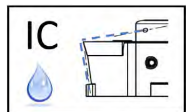

Anwendungsbereich Langdrehen
Range of application turning

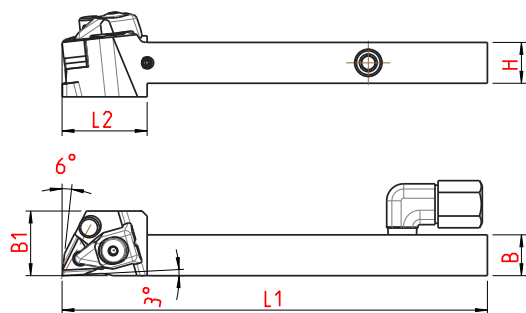

Bestell Nummer Order Number	Bezeichnung Description	L1	L2	B	H	B1	für Wendepplatte for insert
01-0562	DWJN.R.1212.K06.2IK	125	25	12	12	19	WN..06 04 ..
01-0563	DWJN.R.1616.K06.2IK	125	25	16	16	19	

Abmessungen in mm
Dimensions in mm

Ersatzteile / Spare parts			
004.00.22	001.01.602	001.01.601	001.01.600

Weitere Größen auf Anfrage
other sizes on request

Wendepplattenhalter Typ DC.. Platte
Turret plate holder type DC.. insert



Anwendungsbereich Kopierdrehen
Range of application copy turning

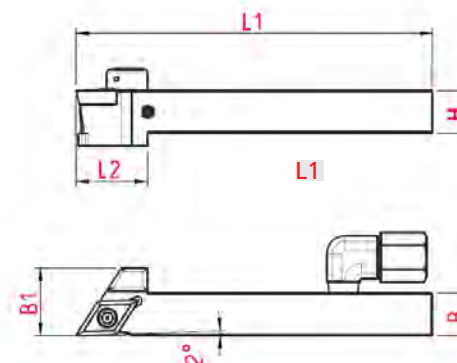

Bestell Nummer Order Number	Bezeichnung Description	L1	L2	H	B	B1	für Wendepplatte for insert
01-0558	SDAC.R.1012.H11.2.IK	100	20	12	10	19	DC..11 T3..
01-1285	SDAC.L.1012.H11.2.IK	100	20	12	10	19	
01-0534	SDAC.R.1212.H11.2.IK	100	20	12	12	19	
01-0535	SDAC.L.1212.H11.2.IK	100	20	12	12	19	
01-0536	SDAC.R.1616.H11.2.IK	100	20	16	16	19	
01-0537	SDAC.L.1616.H11.2.IK	100	20	16	16	19	
01-1434	SDAC.R.2020.H11.2.IK	100	22	20	20	20	
01-1435	SDAC.L.2020.H11.2.IK	100	22	20	20	20	

Abmessungen in mm
Dimensions in mm

Wendepplatten siehe Seite 2.10 – 2.11
insert see page 2.10 – 2.11

Ersatzteile / Spare parts	
004.00.22	001.01.15

Weitere Größen auf Anfrage
other sizes on request

Wendeplattenhalter Typ DC.. Platte
Turret plate holder type DC.. insert

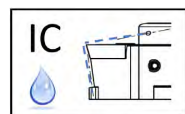

Anwendungsbereich Kopierdrehen
Range of application copy turning

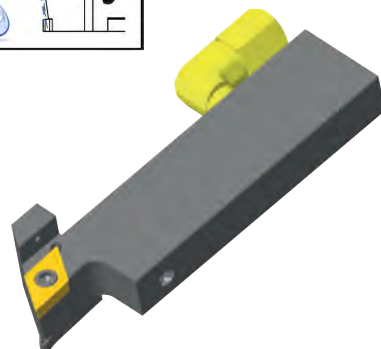
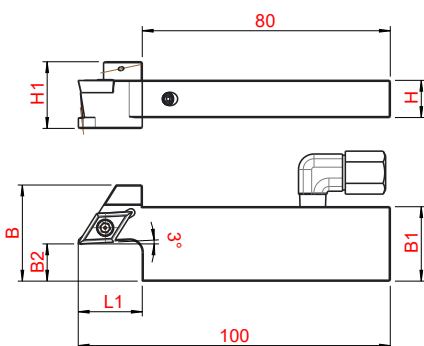

Bestell Nummer Order Number	Bezeichnung Description	L1	H	H1	B	B1	B2	für Wendeplatte for insert
01-1413	SDJCR.1020.H11.2IK.A10	20	10	18,5	29	20	10	DC..11 T3..
01-1310	SDJCR.1224.H11.2IK.A12	20	12	21,5	31	24	12	
01-1313	SDJCR.1232.H11.2IK.A20	20	12	21,5	39	32	20	
01-1306	SDJCR.1632.H11.2IK.A16	22	16	25,5	35	32	16	
01-1314	SDJCR.1646.H11.2IK.A30	22	16	25,5	51	46	30	

Abmessungen in mm
Dimensions in mm

Wendeplatten siehe Seite 2.10 – 2.11
insert see page 2.10 – 2.11

Ersatzteile / Spare parts	
004.00.22	001.01.15

Weitere Größen auf Anfrage
other sizes on request

Wendeplattenhalter Typ DC.. Platte
Turret plate holder type DC.. insert

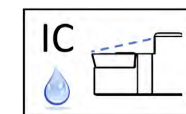

Anwendungsbereich Kopierdrehen
Range of application copy turning

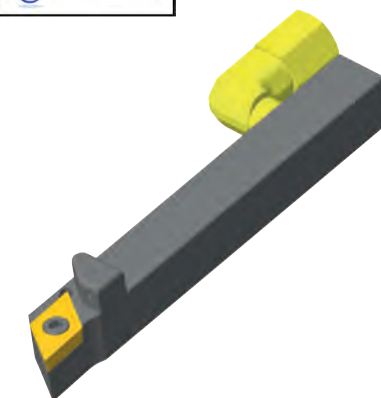
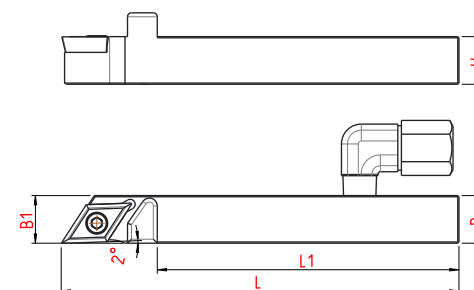

Bestell Nummer Order Number	Bezeichnung Description	L	L1	B	H	B1	für Wendeplatte for insert
01-0411	SDACR.1012.H07.IK	100	80	12	10	14	DC..07 02..
01-0340	SDACL.1012.H07.IK	100	80	12	10	14	
01-0129	SDACR.1212.H07.IK	100	80	12	12	16	
01-1253	SDACL.1212.H07.IK	100	80	12	12	16	DC..11 T3..
01-0412	SDACR.1012.H11.IK	100	76	12	10	15	
01-1287	SDACL.1012.H11.IK	100	76	12	10	15	
01-0319	SDACR.1212.H11.IK	100	76	12	12	18	
01-0320	SDACL.1212.H11.IK	100	76	12	12	18	
01-0520	SDACR.1212.H11.01.IK	100	78	12	12	19	
01-0575	SDACL.1212.H11.01.IK	100	78	12	12	19	
01-0321	SDACR.1616.H11.IK	100	76	16	16	22	
01-0322	SDACL.1616.H11.IK	100	76	16	16	22	
01-0324	SDACR.2020.H11.IK	100	75	20	20	20	
01-0323	SDACL.2020.H11.IK	100	75	20	20	20	

Abmessungen in mm
Dimensions in mm

Ersatzteile / Spare parts	
004.00.22	001.01.15 für DC..11 T3..
	001.01.01 für DC..07 02..

Wendeplatten siehe Seite 2.10 – 2.11
insert see page 2.10 – 2.11

Weitere Größen auf Anfrage
other sizes on request

Wendeplattenhalter Typ DC.. Platte
Turret plate holder type DC.. insert

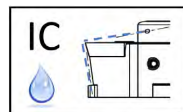

Anwendungsbereich Kopierdrehen
Range of application copy turning

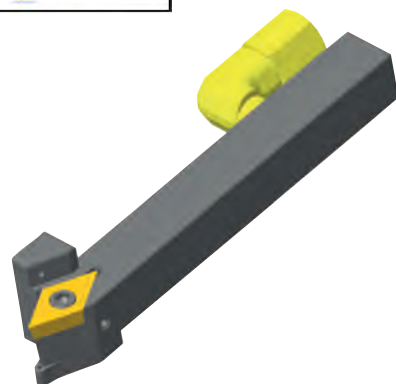
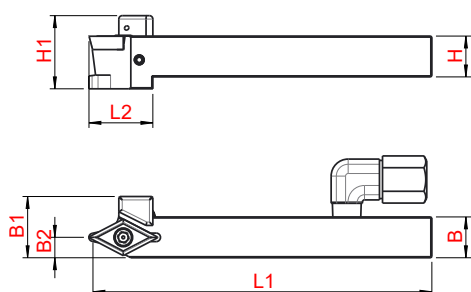

Bestell Nummer Order Number	Bezeichnung Description	L1	L2	B	H	B1	B2	H1	für Wendeplatte for insert
01-1282	SDNC.N.1212.H11.2IK	100	20	12	12	18	6	21,5	DC..11 T3 ..
01-0539	SDNC.N.1616.H11.2IK	100	20	16	16	20	8	25,5	

Abmessungen in mm
Dimensions in mm

Wendeplatten siehe Seite 2.10 – 2.11
insert see page 2.10 – 2.11

Ersatzteile / Spare parts	
004.00.22	001.01.15

Weitere Größen auf Anfrage
other sizes on request

Wendeplattenhalter Typ DC.. Platte
Turret plate holder type DC.. insert

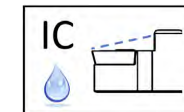

Anwendungsbereich Kopierdrehen
Range of application copy turning

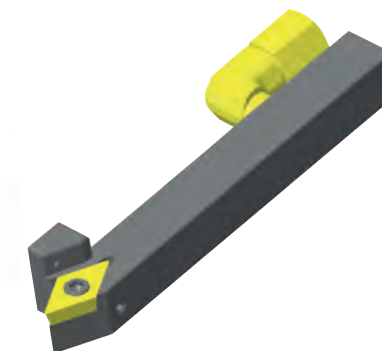
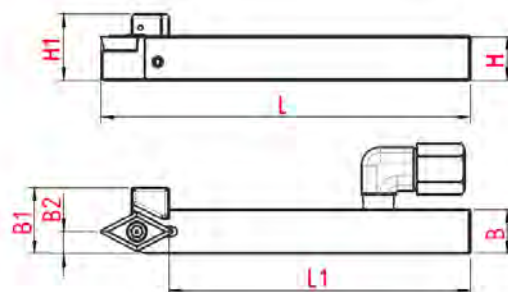

Bestell Nummer Order Number	Bezeichnung Description	L	L1	B	H	H1	B1	B2	für Wendeplatte for insert
01-1281	SDNC.N.1012.H07.IK	100	82	12	10	16	16	5	DC..07 02..
01-0466	SDNC.N.1212.H07.IK	100	82	12	10	18	18	6	
01-0338	SDNC.N.1212.H11.IK	100	82	12	12	18	18	6	DC..11 T3..
01-0337	SDNC.N.1616.H11.IK	100	82	16	16	22	22	8	

Abmessungen in mm
Dimensions in mm

Wendeplatten siehe Seite 2.10 – 2.11
insert see page 2.10 – 2.11

Ersatzteile / Spare parts	
004.00.22	001.01.15 für DC.. 11 T3 ..
	001.01.01 für DC.. 07 02 ..

Weitere Größen auf Anfrage
other sizes on request

Wendeplattenhalter Typ DC.. Platte
Turret plate holder type DC.. insert

Anwendungsbereich Kopierdrehen
Range of application copy turning



Bestell Nummer Order Number	Bezeichnung Description	L	B	H	für Wendeplatte for insert
01-0081	SDAC.R.1010.K07	125	10	10	DC.. 07 02 ..
01-0071	SDAC..L.1010.K07	125	10	10	
01-0083	SDAC.R.1212.K07	125	12	12	
01-0073	SDAC.L.1212.K07	125	12	12	
01-0086	SDAC.R.1616.K07	125	16	16	
01-0076	SDAC.L.1616.K07	125	16	16	
01-0082	SDAC.R.1010.K11	125	10	10	DC.. 11 T3 ..
01-1288	SDAC..L.1010.K11	125	10	10	
01-0084	SDAC.R.1212.K11	125	12	12	
01-0074	SDAC.L.1212.K11	125	12	12	
01-0088	SDAC.R.1616.K11	125	16	16	
01-0077	SDAC.L.1616.K11	125	16	16	

Abmessungen in mm
Dimensions in mm

Wendeplatten siehe Seite 2.10 – 2.11
insert see page 2.10 – 2.11

Ersatzteile / Spare parts

001.01.15 für DC..11 T3..
001.01.01 für DC..07 02..

Weitere Größen auf Anfrage
other sizes on request

Wendeplattenhalter Typ DC.. Platte
Turret plate holder type DC.. insert

Anwendungsbereich Kopierdrehen
Range of application copy turning

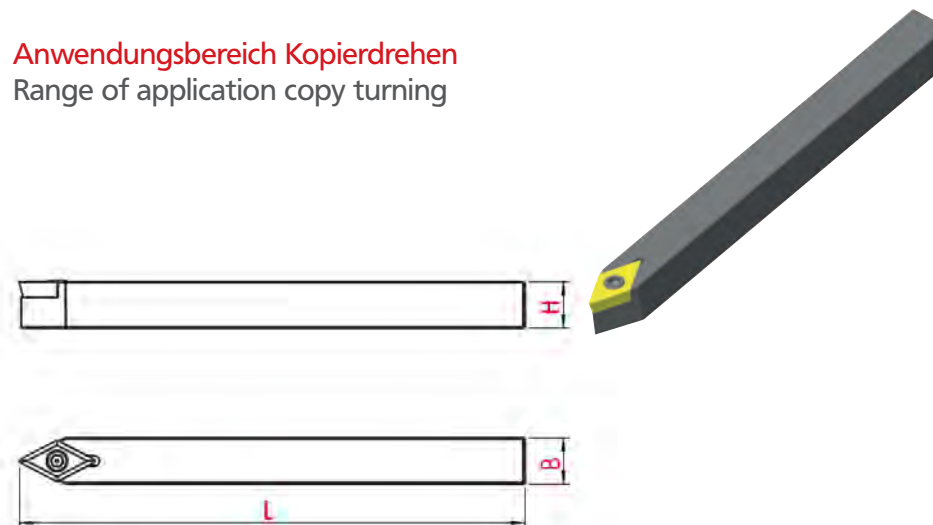

Bestell Nummer Order Number	Bezeichnung Description	L	B	H	für Wendeplatte for insert
01-0100	SDNC.N.1010.K07	125	10	10	DC.. 07 02 ..
01-0101	SDNC.N.1212.K07	125	12	12	
01-0104	SDNC.N.1616.K07	125	16	16	
01-0102	SDNC.N.1212.K11	125	12	12	DC.. 11 T3 ..
01-0105	SDNC.N.1616.K11	125	16	16	
01-0106	SDNC.N.2020.K11	125	20	20	

Abmessungen in mm
Dimensions in mm

Wendeplatten siehe Seite 2.10 – 2.11
insert see page 2.10 – 2.11

Ersatzteile / Spare parts

001.01.15 für DC.. 11 T3 ..
001.01.01 für DC.. 07 02 ..

Weitere Größen auf Anfrage
other sizes on request

Wendeplattenhalter Typ DC..Platte
Turret plate holder type DC.. insert

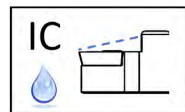

Anwendungsbereich Kopierdrehen
Range of application copy turning

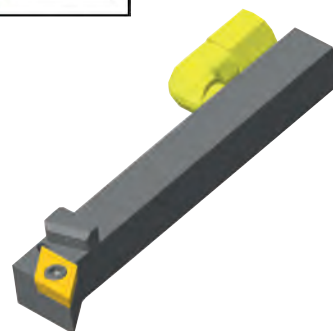
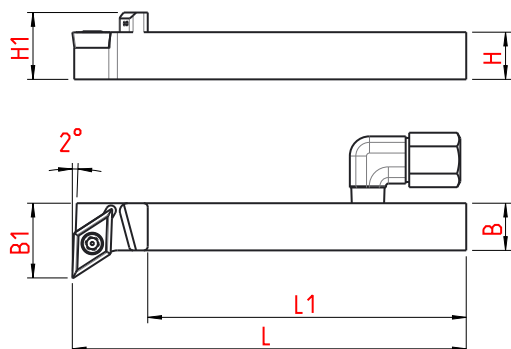

Bestell Nummer Order Number	Bezeichnung Description	L	L1	B	H	H1	B1	für.Wendeplatte for insert
01-0560	SDUC.R.1212.H07.IK	100	84	12	12	17	17,0	DC.. 07 02 ..
01-1296	SDUC.L.1212.H07.IK	100	84	12	12	17	17,0	
01-1297	SDUC.R.1212.H11.IK	100	81	12	12	17	19,0	DC.. 11 T3 ..
01-1298	SDUC.L.1212.H11.IK	100	81	12	12	17	19,0	
01-1299	SDUC.R.1616.H11.IK	100	81	16	16	22	23,5	
01-1300	SDUC.L.1616.H11.IK	100	81	16	16	22	23,5	
01-1301	SDUC.R.2020.H11.IK	100	78	20	20	26	27,5	
01-0525	SDUC.L.2020.H11.IK	100	78	20	20	26	27,5	

Abmessungen in mm
Dimensions in mm

Wendeplatten siehe Seite 2.10 – 2.11
insert see page 2.10 – 2.11

Ersatzteile / Spare parts	
004.00.22	001.01.15 für DC.. 11 T3 ..
	001.01.01 für DC.. 07 02 ..

Weitere Größen auf Anfrage
other sizes on request

Wendeplattenhalter Typ DC.. Platte
Turret plate holder type DC..insert

Anwendungsbereich Kopierdrehen
Range of application copy turning

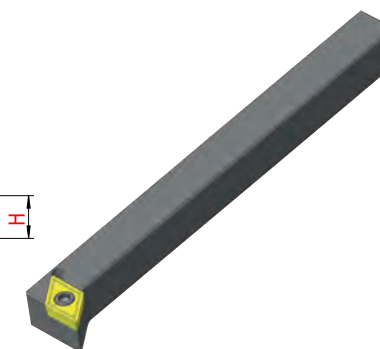
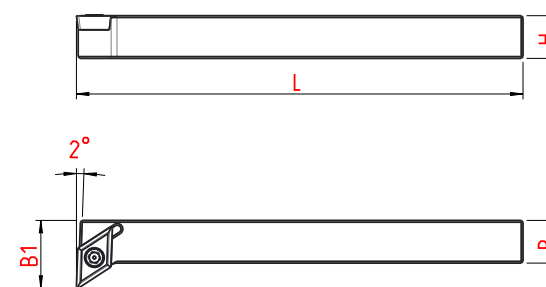

Bestell Nummer Order Number	Bezeichnung Description	L	B	H	B1	für.Wendeplatte for insert
01-0096	SDUC.R.1112.K07	130	12	12	17,5	DC.. 07 02 ..
01-0092	SDUC.L.1212.K07	130	12	12	17,5	
01-0473	SDUC.R.1212.K11	130	12	12	19	DC.. 11 T3 ..
01-0557	SDUC.L.1212.K11	130	12	12	19	
01-0097	SDUC.R.1616.K11	130	16	16	22,5	
01-0093	SDUC.L.1616.K11	130	16	16	22,5	
01-0098	SDUC.R.2020.K11	130	20	20	27,5	
01-0094	SDUC.L.2020.K11	130	20	20	27,5	

Abmessungen in mm
Dimensions in mm

Wendeplatten siehe Seite 2.10 – 2.11
insert see page 2.10 – 2.11

Ersatzteile / Spare parts	
	001.01.15 für DC.. 11 T3 ..
	001.01.01 für DC.. 07 02 ..

Weitere Größen auf Anfrage
other sizes on request

Wendeplattenhalter Typ DC.. Platte
Turnet plate holder type DC.. insert

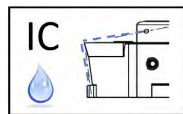

Anwendungsbereich Kopierdrehen
Range of application copy turning

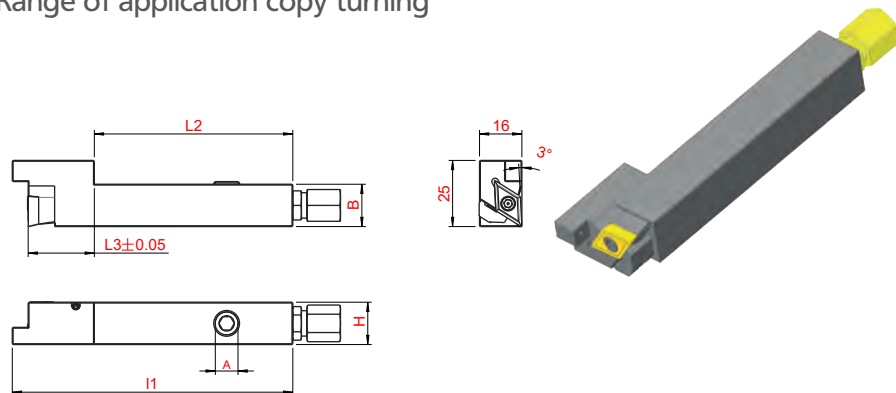

Bestell Nummer Order Number	Bezeichnung Description	L1	L2	B	H	L3	A	für Wendeplatte for insert
01-1431	Y.SDJCR.1212.H11.2IK	106	78	12	12	22	M8x1	DC.. 11 T3 ..
01-1419	Y.SDJCR.1616.H11.2IK	106	75	16	16	25	G1/8"	

Abmessungen in mm
Dimensions in mm

Wendeplatten siehe 2.10 - 2.11
insert see page 2.10 - 2.11

Ersatzteile / Spare parts	
004.00.22/M8x1	001.01.15
004.00.33/G1/8"	001.01.15

Zustellung über y-Achse
infeed via y-axis

Weitere Größen auf Anfrage
other sizes on request

Wendeplattenhalter Typ YW..Platte
Turret plate holder type yw.. insert

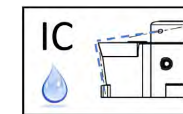

Anwendungsbereich Kopierdrehen
Range of application copy turning

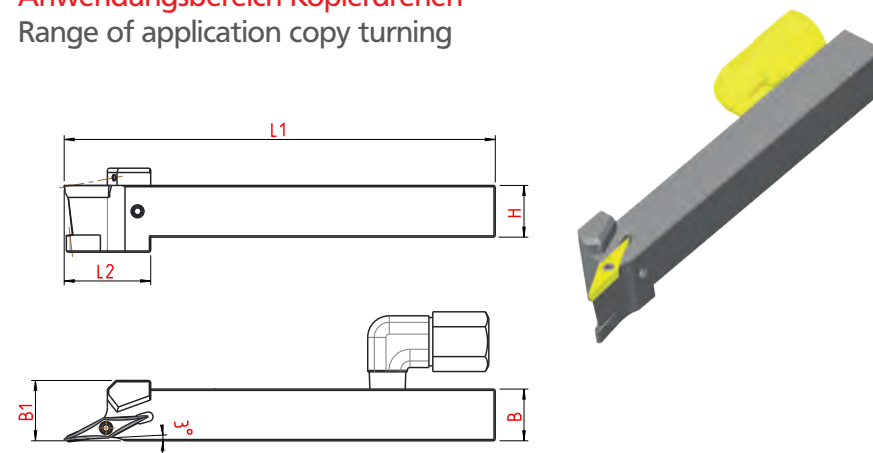

Bestell Nummer Order Number	Bezeichnung Description	L1	L2	B	H	B1	für Wendeplatte for insert
01-1429	SYJCR.1012.H11.2IK	100	20	12	10	14	YW.. 11 T2 ..
01-1430	SYJCL.1012.H11.2IK	100	20	12	10	14	
01-0580	SYJCR.1212.H11.2IK	100	20	12	12	14	
01-0581	SYJCL.1212.H11.2IK	100	20	12	12	14	
01-0582	SYJCR.1212.H16.2IK	100	23	12	12	16	YW.. 16 T3 ..
01-0583	SYJCL.1212.H16.2IK	100	23	12	12	16	
01-1427	SYJCR.1616.H16.2IK	100	23	16	16	16	
01-1428	SYJCL.1616.H16.2IK	100	23	16	16	16	

Abmessungen in mm
Dimensions in mm

Ersatzteile / Spare parts	
004.00.22	001.01.25 YW.. 11 T2 ..
	001.01.85 YW.. 16 T3 ..

Weitere Größen auf Anfrage
other sizes on request

Wendeplattenhalter Typ CC.. Platte
Turret plate holder type CC.. insert

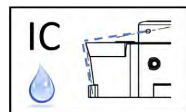

Anwendungsbereich Langdrehen
Range of application turning

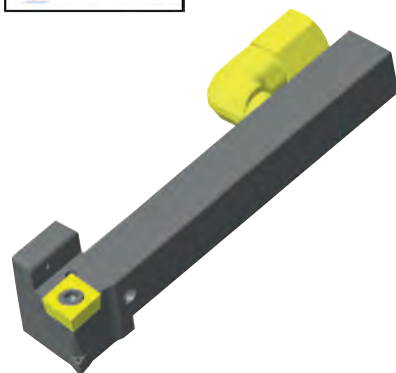
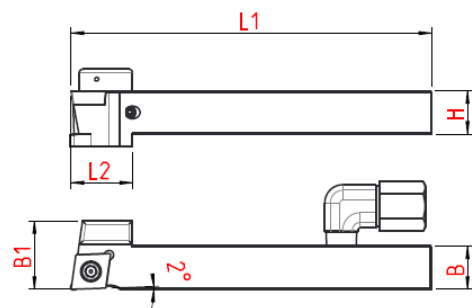

Bestell Nummer Order Number	Bezeichnung Description	L1	L2	B	H	B1	für Wendeplatte for insert
01-1305	SCAC.R.1012.H09.2IK	100	17	12	10	19	CC.. 09 T3 ..
01-0549	SCAC.R.1212.H09.2IK	100	17	12	12	19	
01-1312	SCAC.R.1616.H09.2IK	100	17	16	16	19	

Abmessungen in mm
Dimensions in mm

Wendeplatten siehe Seite 2.9
insert see page 2.9

Ersatzteile / Spare parts	
004.00.22	001.01.15

Weitere Größen auf Anfrage
other sizes on request

Wendeplattenhalter Typ CC.. Platte
Turret plate holder type CC.. insert

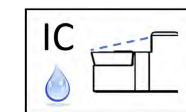

Anwendungsbereich Langdrehen
Range of application turning

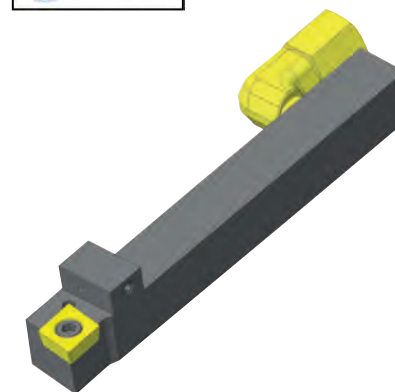
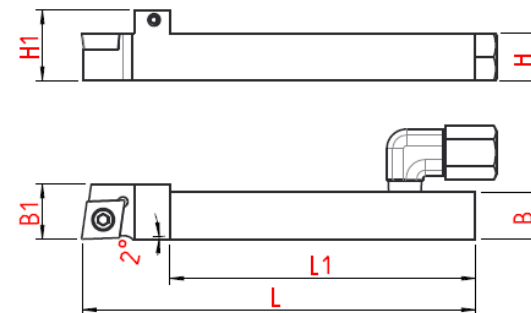

Bestell Nummer Order Number	Bezeichnung Description	L	L1	B	H	H1	B1	für Wendeplatte for insert
01-0001	SCAC.R.1012.H06.IK	100	82	12	10	16	12	CC...06 02...
01-1302	SCAC.L.1012.H06.IK	100	82	12	10	16	12	
01-0441	SCAC.R.1212.H06.IK	100	82	12	12	18	12	
01-1303	SCAC.L.1212.H06.IK	100	85	12	12	18	12	CC...09 T3...
01-0389	SCAC.R.1012.H09.IK	100	78	12	10	16	14	
01-1304	SCAC.L.1012.H09.IK	100	78	12	10	16	14	
01-0362	SCAC.R.1212.H09.IK	100	78	12	12	18	14	
01-0400	SCAC.L.1212.H09.IK	100	78	12	12	18	14	
01-0363	SCAC.R.1616.H09.IK	100	78	16	16	22	16	
01-0516	SCAC.L.1616.H09.IK	100	78	16	16	22	16	

Abmessungen in mm
Dimensions in mm

Wendeplatten siehe Seite 2.9
insert see page 2.9

Ersatzteile / Spare parts	
004.00.22	001.01.15 für CC.. 09 T3 ..
	001.01.01 für CC.. 06 02 ..

Weitere Größen auf Anfrage
other sizes on request

Wendeplattenhalter Typ VC.. Platte
Turret plate holder type VC..insert

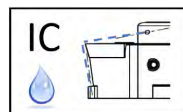

Anwendungsbereich Kopierdrehen
Range of application copy turning

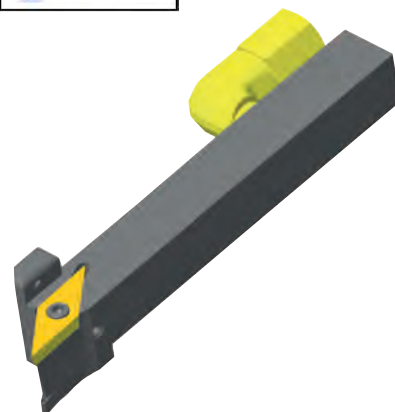
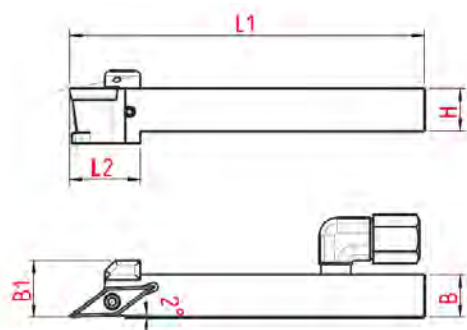

Bestell Nummer Order Number	Bezeichnung Description	L1	L2	B	H	B1	für.Wendeplatte for insert
01-1283	SVAC.R.1012.H11.2.IK	100	20	12	10	16	VC.. 11 03..
01-1291	SVAC.L.1012.H11.2.IK	100	20	12	10	16	
01-0540	SVAC.R.1212.H11.2.IK	100	20	12	12	16	
01-0541	SVAC.L.1212.H11.2.IK	100	20	12	12	16	
01-1284	SVAC.R.1616.H11.2.IK	100	20	16	16	16	VC.. 13 03..
01-1293	SVAC.L.1616.H11.2.IK	100	20	16	16	16	
01-1286	SVAC.R.1212.H13.2.IK	100	20	12	12	16	
01-1292	SVAC.L.1212.H13.2.IK	100	20	12	12	16	
01-1289	SVAC.R.1616.H13.2.IK	100	20	16	16	16	VC.. 16 04..
01-1294	SVAC.L.1616.H13.2.IK	100	20	16	16	16	
01-1290	SVAC.R.1616.H16.2.IK	100	20	16	16	18	
01-1295	SVAC.L.1616.H16.2.IK	100	20	16	16	18	

Wendeplatten siehe Seite 2.12
insert see page 2.12

Abmessungen in mm
Dimensions in mm

Ersatzteile / Spare parts	
004.00.22	001.01.08 für VC.. 11 03 ..
	001.01.07 für VC.. 13 03 ..
	001.01.15 für VC.. 16 04 ..

Weitere Größen auf Anfrage
other sizes on request

Wendeplattenhalter Typ VC.. Platte
Turret plate holder type VC.. insert



Anwendungsbereich Kopierdrehen
Range of application copy turning

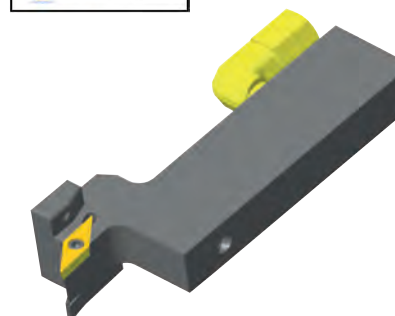
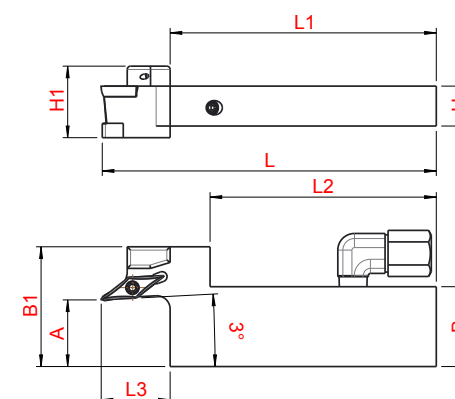

Bestell Nummer Order Number	Bezeichnung Description	L	L1	L2	L3	H	H1	B	B1	A	für.Wendeplatte for insert
01-0573	SVJCR.1224.H11.2IK.A12	100	80	/	20	12	21,5	24	28	12	VC.. 11 03..
01-0574	SVJCR.1224.H11.2IK.A20	100	80	68	20	12	21,5	24	36	20	
01-1410	SVJCR.1632.H13.2IK.A16	100	80	/	23	16	26	32	35	16	VC.. 13 03..
01-1411	SVJCR.1632.H13.2IK.A30	100	80	62	23	16	26	32	49	30	
01-1307	SVJCR.1632.H16.2IK.A16	100	80	/	23	16	25,5	32	35	16	VC.. 16 04..
01-1364	SVJCR.1632.H16.2IK.A30	100	80	62	23	16	25,5	32	49	30	

Abmessungen in mm
Dimensions in mm

Wendeplatten siehe Seite 2.12
insert see page 2.12

Ersatzteile / Spare parts	
004.00.22	001.01.08 für VC..11 03..
	001.01.07 für VC..13 03..
	001.01.15 für VC..16 04..

Weitere Größen auf Anfrage
other sizes on request

Wendeplattenhalter Typ VC.. Platte
Turret plate holder type VC.. insert

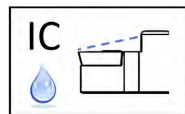

Anwendungsbereich Kopierdrehen
Range of application turning

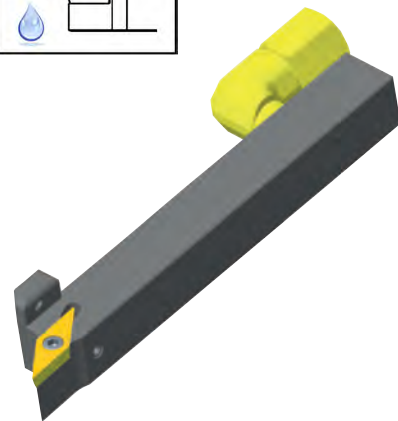
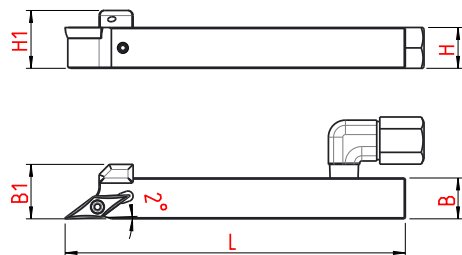

Bestell Nummer Order Number	Bezeichnung Description	L	L1	B	H	H1	B1	für Wendeplatte for insert
01-0464	SVAC.R.1012.H11.IK	100	80	12	10	14	14	VC.. 11 03...
01-0364	SVAC.L.1012.H11.IK	100	80	12	10	14	14	
01-0346	SVAC.R.1212.H11.IK	100	80	12	12	17	16	
01-0347	SVAC.L.1212.H11.IK	100	80	12	12	17	16	
01-0348	SVAC.R.1616.H11.IK	100	80	16	16	22	16	
01-0349	SVAC.L.1616.H11.IK	100	80	16	16	22	16	VC.. 13 03...
01-0373	SVAC.R.1012.H13.IK	100	80	12	10	16	16	
01-0379	SVAC.L.1012.H13.IK	100	80	12	10	16	16	
01-0326	SVAC.R.1212.H13.IK	100	80	12	12	18	16	
01-0343	SVAC.L.1212.H13.IK	100	80	12	12	18	16	
01-0327	SVAC.R.1616.H13.IK	100	80	16	16	22	16	VC.. 16 04...
01-0344	SVAC.L.1616.H13.IK	100	80	16	16	22	16	
01-0371	SVAC.R.1212.H16.IK	100	80	12	12	18	16	
01-0372	SVAC.L.1212.H16.IK	100	80	12	12	18	16	
01-0365	SVAC.R.1616.H16.IK	100	80	16	16	22	16	
01-0366	SVAC.L.1616.H16.IK	100	80	16	16	22	16	

Abmessungen in mm
Dimensions in mm

Wendeplatten siehe Seite 2.12
insert see page 2.12

Ersatzteile / Spare parts	
004.00.22	001.01.08 für VC.. 11 03 ..
	001.01.07 für VC.. 13 03 ..
	001.01.15 für VC.. 16 04 ..

Weitere Größen auf Anfrage
other sizes on request

Wendeplattenhalter Typ VC.. Platte
Turret plate holder type VC.. insert

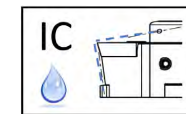

Anwendungsbereich Kopierdrehen
Range of application copy turning

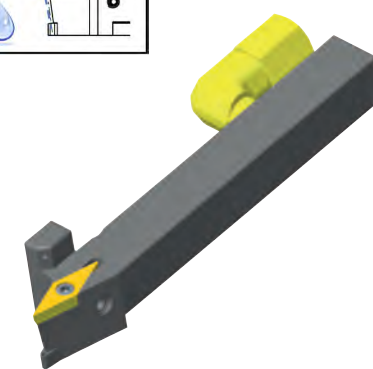
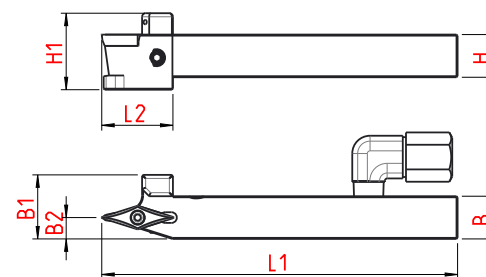

Bestell Nummer Order Number	Bezeichnung Description	L1	L2	B	H	B1	B2	H1	für Wendeplatte for insert
01-1311	SVVC.N.1212.H11.2IK	100	20	12	12	18	6	21,5	VC.. 11 03 ..
01-1320	SVVC.N.1616.H11.2IK	100	20	16	16	21	7	25,5	
01-1319	SVVC.N.1212.H13.2IK	100	20	12	12	18	6	21,5	VC.. 13 03 ..
01-1321	SVVC.N.1616.H13.2IK	100	20	16	16	21	7	25,5	
01-1322	SVVC.N.1616.H16.2IK	100	25	16	16	21	7	25	

Abmessungen in mm
Dimensions in mm

Wendeplatten siehe Seite 2.12
insert see page 2.12

Ersatzteile / Spare parts	
004.00.22	001.01.07 für VC.. 13 03 ..
	001.01.08 für VC.. 11 03 ..

Weitere Größen auf Anfrage
other sizes on request

Wendeplattenhalter Typ VC.. Platte
Turret plate holder type VC.. insert

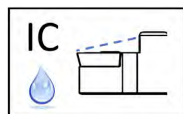

Anwendungsbereich Kopierdrehen
Range of application copy turning

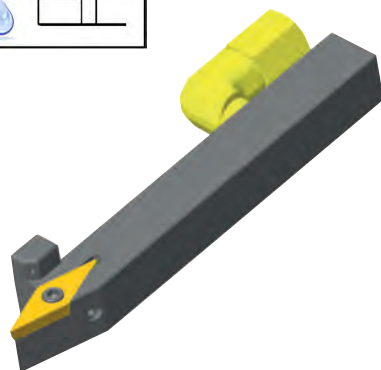
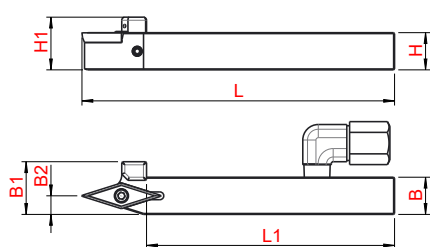

Bestell Nummer Order Number	Bezeichnung Description	L	L1	B	H	H1	B1	B2	für Wendeplatte for insert
01-0356	SVVC.N.1012.H11.IK	100	82	12	10	16	16	5	VC.. 11 03 ..
01-0380	SVVC.N.1212.H11.IK	100	80	12	12	16	16	6	
01-1315	SVVC.N.1616.H11.IK	100	80	16	16	22	20	6	
01-0354	SVVC.N.1212.H13.IK	100	80	12	12	17	17	6	VC.. 13 03 ..
01-0339	SVVC.N.1616.H13.IK	100	80	16	16	22	20	6	VC.. 16 04 ..
01-0437	SVVC.N.1616.H16.IK	100	79	16	16	22	22	8	

Abmessungen in mm
Dimensions in mm

Wendeplatten siehe Seite 2.12
insert see page 2.12

Ersatzteile / Spare parts	
004.00.22	001.01.15 für VC.. 16 04 ..
	001.01.07 für VC.. 13 03 ..
	001.01.08 für VC.. 11 03 ..

Weitere Größen auf Anfrage
other sizes on request

Wendeplattenhalter Typ VC.. Platte
Turret plate holder type VC.. insert

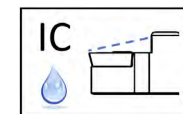

Anwendungsbereich Kopierdrehen
Range of application copy turning

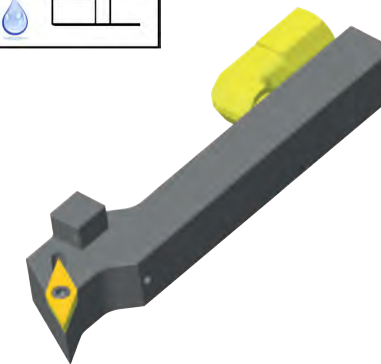
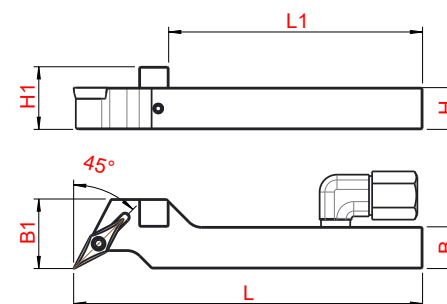

Bestell Nummer Order Number	Bezeichnung Description	L	L1	B	H	H1	B1	für Wendeplatte for insert
01-1317	SVLC.R.1012.H11.IK	100	76,5	12	10	16	18	VC.. 11 03 ..
01-1318	SVLC.L.1012.H11.IK	100	76,5	12	10	16	18	
01-0519	SVLC.R.1212.H11.IK	100	73	12	12	18	20	
01-1316	SVLC.L.1212.H11.IK	100	73	12	12	18	20	
01-0555	SVLC.R.1616.H11.IK	100	73	16	16	22	16	
01-0556	SVLC.L.1616.H11.IK	100	73	16	16	22	16	

Abmessungen in mm
Dimensions in mm

Wendeplatten siehe Seite 2.12
insert see page 2.12

Ersatzteile / Spare parts	
004.00.22	001.01.08 für VC.. 11 03 ..

Weitere Größen auf Anfrage
other sizes on request

Wendeplattenhalter Typ VC.. Platte
Turret plate holder type VC.. insert

Anwendungsbereich Kopierdrehen
Range of application copy turning

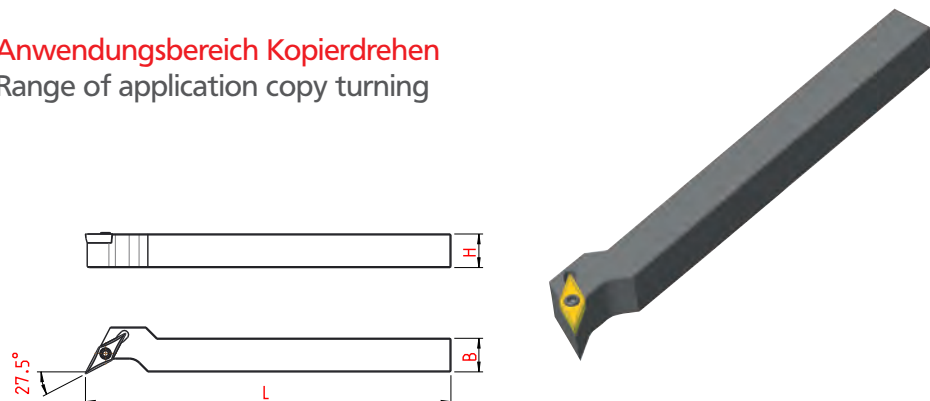

Bestell Nummer Order Number	Bezeichnung Description	L	B	H	für Wendeplatte for insert
01-0254	SVLC.R.1010.K11	130	10	10	VC.. 11 03 ..
01-0246	SVLC.L.1010.K11	130	10	10	
01-0255	SVLC.R.1212.K11	130	12	12	
01-0247	SVLC.L.1212.K11	130	12	12	
01-0257	SVLC.R.1616.K11	130	16	16	
01-0249	SVLC.L.1616.K11	130	16	16	
01-0357	SVLC.R.1616.K13	130	16	16	VC.. 13 03 ..
01-0358	SVLC.L.1616.K13	130	16	16	

Abmessungen in mm
Dimensions in mm

Wendeplatten siehe Seite 2.12
insert see page 2.12

Ersatzteile / Spare parts

001.01.08 für VC.. 11 03 ..
001.01.07 für VC.. 13 03 ..

Weitere Größen auf Anfrage
other sizes on request

Wendeplattenhalter Typ VC.. Platte
Turret plate holder type VC.. insert

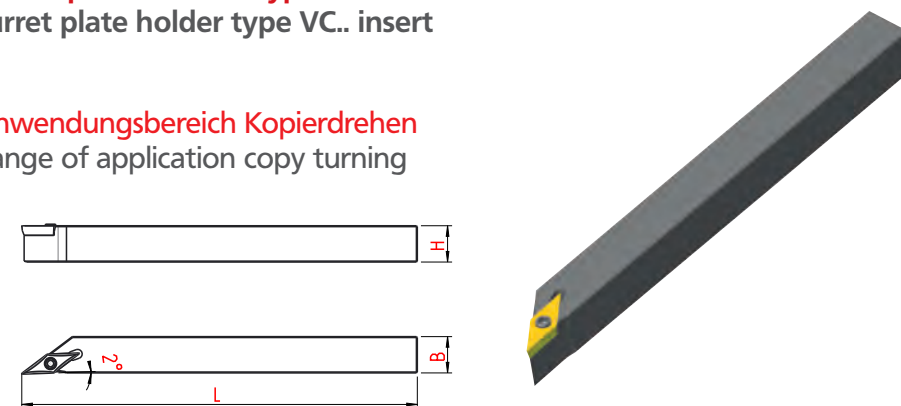
Anwendungsbereich Kopierdrehen
Range of application copy turning



Bestell Nummer Order Number	Bezeichnung Description	L	B	H	für Wendeplatte for insert
01-0226	SVAC.R.1010.K11	130	10	10	VC.. 11 03 ..
01-0206	SVAC.L.1010.K11	130	10	10	
01-0229	SVAC.R.1212.K11	130	12	12	
01-0209	SVAC.L.1212.K11	130	12	12	
01-0234	SVAC.R.1616.K11	130	16	16	
01-0367	SVAC.L.1616.K11	130	16	16	
01-0227	SVAC.R.1010.K13	130	10	10	VC.. 13 03 ..
01-0207	SVAC.L.1010.K13	130	10	10	
01-0230	SVAC.R.1212.K13	130	12	12	
01-0210	SVAC.L.1212.K13	130	12	12	
01-0235	SVAC.R.1616.K13	130	16	16	
01-0214	SVAC.L.1616.K13	130	16	16	
01-0239	SVAC.R.2020.K13	130	20	20	VC.. 16 04 ..
01-0218	SVAC.L.2020.K13	130	20	20	
01-0233	SVAC.R.1212.K16	130	12	12	
01-0559	SVAC.L.1212.K16	130	12	12	
01-0237	SVAC.R.1616.K16	130	16	16	
01-0216	SVAC.L.1616.K16	130	16	16	
01-0241	SVAC.R.2020.K16	130	20	20	
01-0220	SVAC.L.2020.K16	130	20	20	

Abmessungen in mm
Dimensions in mm

Wendeplatten siehe Seite 2.12
insert see page 2.12

Ersatzteile / Spare parts

001.01.08 für VC.. 11 03 ..
001.01.07 für VC.. 13 03 ..
001.01.15 für VC.. 16 04 ..

Weitere Größen auf Anfrage
other sizes on request

Wendepplattenhalter Typ VC.. Platte
Turret plate holder type VC.. insert

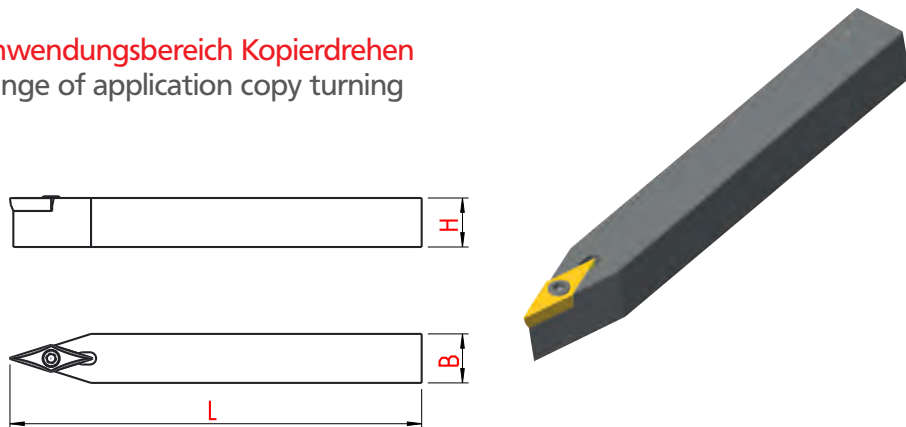
Anwendungsbereich Kopierdrehen
Range of application copy turning



Bestell Nummer Order Number	Bezeichnung Description	L	B	H	für Wendepplatte for insert
01-0265	SVVC.N.1010.K11	130	10	10	VC.. 11 03 ..
01-0267	SVVC.N.1212.K11	130	12	12	
01-0266	SVVC.N.1010.K13	130	10	10	VC.. 13 03 ..
01-0268	SVVC.N.1212.K13	130	12	12	
01-0271	SVVC.N.1616.K13	130	16	16	VC.. 16 04 ..
01-0272	SVVC.N.1616.K16	130	16	16	

Abmessungen in mm
Dimensions in mm

Wendepplatten siehe Seite 2.12
insert see page 2.12

Ersatzteile / Spare parts	
	
001.01.08 für VC.. 11 03 ..	
001.01.07 für VC.. 13 03 ..	
001.01.15 für VC.. 16 04 ..	

Weitere Größen auf Anfrage
other sizes on request

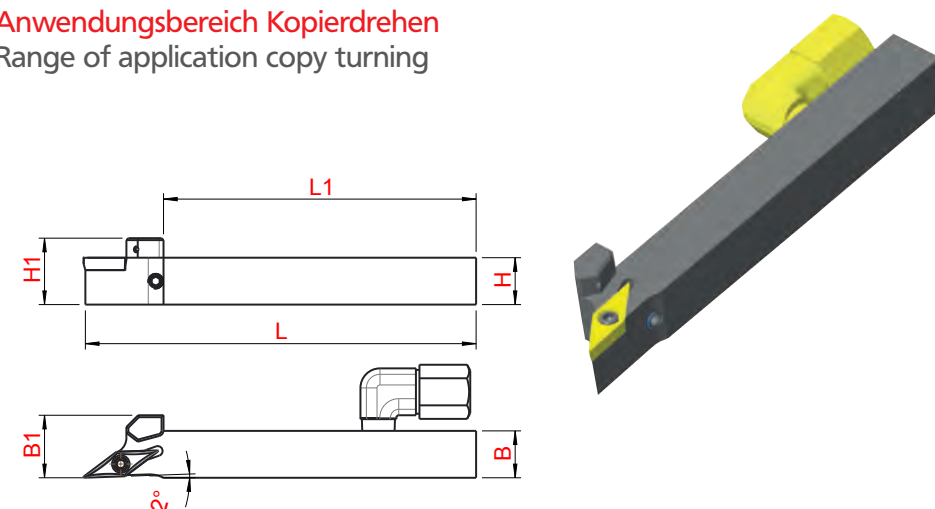
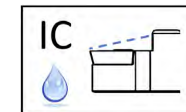

Wendepplattenhalter Typ VB.. Platte
Turret plate holder type VB.. insert

Anwendungsbereich Kopierdrehen
Range of application copy turning



Bestell Nummer Order Number	Bezeichnung Description	L	L1	B	H	H1	B1	für Wendepplatte for insert
01-0421	SVAB.R.1012.H11.IK	100	80	12	10	16	16	VB.. 11 03 ..
01-0420	SVAB.L.1012.H11.IK	100	80	12	10	16	16	
01-0391	SVAB.R.1212.H11.IK	100	80	12	12	17	16	
01-0445	SVAB.L.1212.H11.IK	100	80	12	12	17	16	
01-0493	SVAB.R.1616.H11.IK	100	80	16	16	22	16	
01-0202	SVAB.L.1616.H11.IK	100	80	16	16	22	16	
01-0511	SVAB.R.1214.H16.IK	100	80	14	12	17	18	VB.. 16 04 ..
01-1251	SVAB.L.1214.H16.IK	100	80	14	12	17	18	
01-0431	SVAB.R.1616.H16.IK	100	80	16	16	20	16	
01-1250	SVAB.L.1616.H16.IK	100	80	16	16	20	16	

Abmessungen in mm
Dimensions in mm

Ersatzteile / Spare parts	
	
004.00.22	001.01.08 für VB.. 11 03 ..
	001.01.15 für VB.. 16 04 ..

Weitere Größen auf Anfrage
other sizes on request

Wendeplattenhalter Typ VB.. Platte
Turret plate holder type VB.. insert

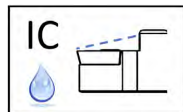

Anwendungsbereich Kopierdrehen
Range of application copy turning

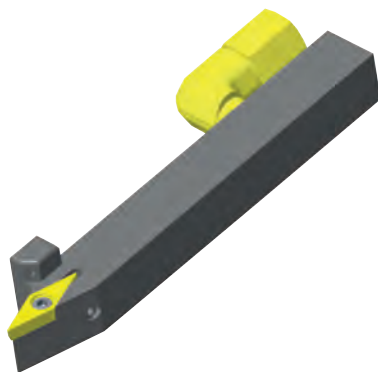
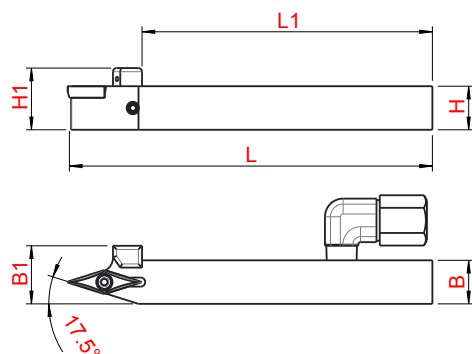

Bestell Nummer Order Number	Bezeichnung Description	L	L1	B	H	H1	B1	für.Wendeplatte for insert
01-0432	SVVB.N.1212.H11.IK	100	80	12	12	17	16	VB...11 03...
01-0436	SVVB.N.1616.H11.IK	100	80	16	16	20	18	
01-0385	SVVB.N.1212.H16.IK	100	78	12	12	17	18	VB...16 04...
01-0261	SVVB.N.1616.H16.IK	100	78	16	16	20	20	

Abmessungen in mm
Dimensions in mm

Ersatzteile / Spare parts	
004.00.22	001.01.08 für VB.. 11 03 ..
	001.01.15 für VB.. 16 04 ..

Weitere Größen auf Anfrage
other sizes on request

Innendrehhalter HORN Typ 105
Internal turning holder HORN type 105

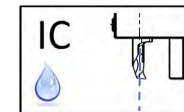

Anwendungsbereich Innenbearbeitung
Range of application internal turning tools

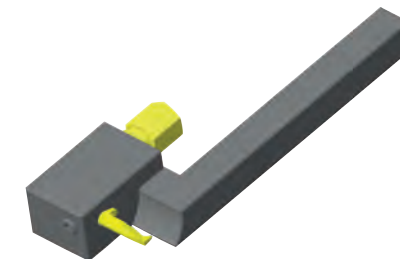
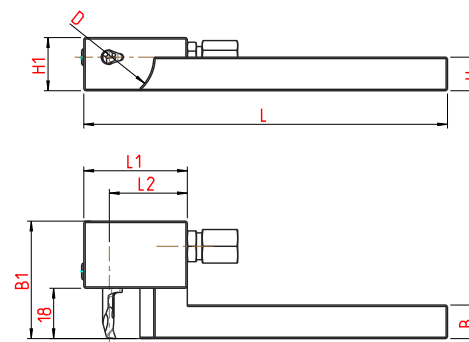

Bestell Nummer Order Number	Bezeichnung Description	L	B	H	L1	L2	D	H1	B1	für Wendeplatte for insert
01-1323	962.08.01.R.IK	130	8	8	37	27	30	15	42	HORN Typ 105
01-1324	962.08.02.L.IK	130	8	8	37	27	30	15	42	
01-1325	962.10.01.R.IK	130	10	10	37	27	30	17	42	
01-1326	962.10.02.L.IK	130	10	10	37	27	30	17	42	
01-1327	962.12.01.R.IK	130	12	12	37	27	30	19	42	
01-1328	962.12.02.L.IK	130	12	12	37	27	30	19	42	
01-1329	962.16.01.R.IK	130	16	16	37	27	34	23	42	
01-1330	962.16.02.L.IK	130	16	16	37	27	34	23	42	
01-1331	962.20.01.R.IK	130	20	20	37	27	34	27	42	
01-1332	962.20.02.L.IK	130	20	20	37	27	34	27	42	

Abmessungen in mm
Dimensions in mm

Ersatzteile / Spare parts	
004.00.19	001.01.36

Weitere Größen auf Anfrage
other sizes on request

Innendrehhalter HORN Typ 105
Internal turning holder HORN type 105

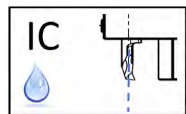

Anwendungsbereich Innenbearbeitung
Range of application internal turning tools

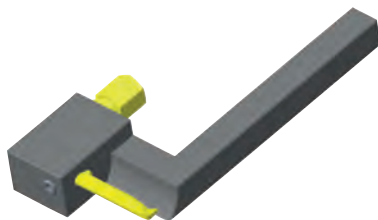
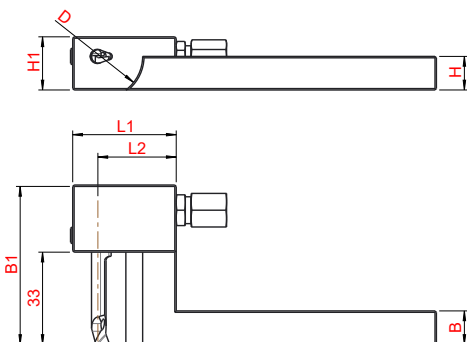

Bestell Nummer Order Number	Bezeichnung Description	L	B	H	L1	L2	D	H1	B1	für.Wendeplatte for insert
01-1333	962.10.03.R.IK	130	10	10	37	27	30	17	57	HORN Typ 105
01-1334	962.10.04.L.IK	130	10	10	37	27	30	17	57	
01-1335	962.12.03.R.IK	130	12	12	37	27	30	19	57	
01-1336	962.12.04.L.IK	130	12	12	37	27	30	19	57	
01-1337	962.16.03.R.IK	130	16	16	37	27	34	23	57	
01-1338	962.16.04.L.IK	130	16	16	37	27	34	23	57	

Abmessungen in mm
Dimensions in mm

Ersatzteile / Spare parts

004.00.19	001.01.36

Weitere Größen auf Anfrage
other sizes on request

Innendrehhalter HORN Typ 105
Internal turning holder HORN type 105

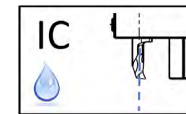

Anwendungsbereich Innenbearbeitung
Range of application internal turning tools

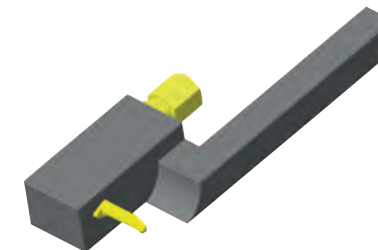
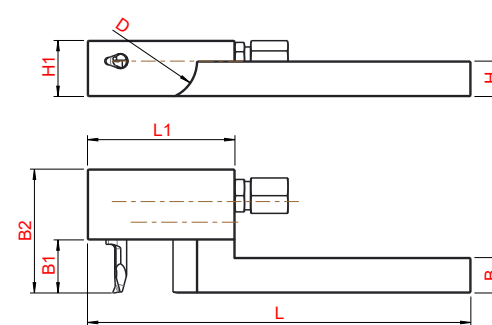

Bestell Nummer Order Number	Bezeichnung Description	L	B	H	L1	B1	D	H1	B2	für Wendeplatte for insert
01-1345	963.12.01.R IK	130	12	12	50	18	46	19	42	HORN Typ 105
01-1346	963.12.02.L IK	130	12	12	50	18	46	19	42	
01-1347	963.16.01.R IK	130	16	16	55	18	52	23	42	
01-1348	963.16.02.L IK	130	16	16	55	18	52	23	42	

Abmessungen in mm
Dimensions in mm

Ersatzteile / Spare parts

004.00.19	001.01.36

Weitere Größen auf Anfrage
other sizes on request

Wendepplattenhalter HORN Typ 312
Turret plate holder HORN type 312

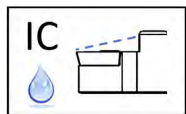

Anwendungsbereich Kopierdrehen, Abstechen
Range of application copy turning, plunging

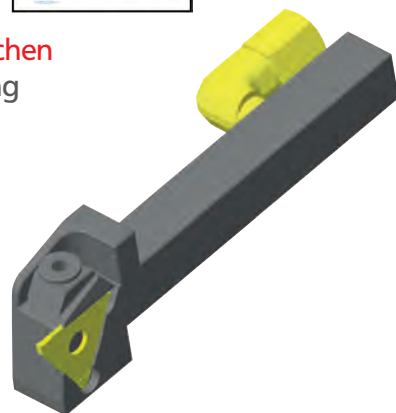
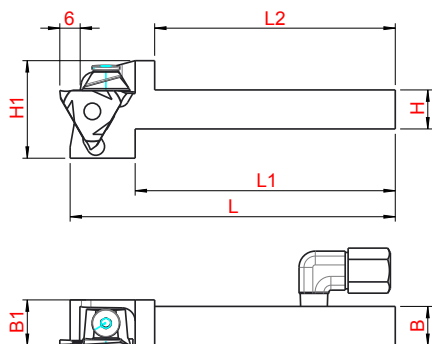

Bestell Nummer Order Number	Bezeichnung Description	L	L1	L2	B	B1	H	H1	für Wendepplatte for insert
01-0566	912.R.1012.01.IK	100	80	74	12	14	10	30	HORN Typ 312 0,5 - 1,9
01-0567	912.L.1012.01.IK	100	80	74	12	14	10	30	
01-0480	912.R.1212.01.IK	100	80	74	12	14	12	30	
01-0460	912.L.1212.01.IK	100	80	74	12	14	12	30	
01-0440	912.R.1616.01.IK	100	80	74	16	16	16	34	
01-0568	912.L.1616.01.IK	100	80	74	16	16	16	34	
01-0469	912.R.1012.02.IK	100	80	74	12	14	10	30	HORN Typ 312 1,9 - 2,9
01-0569	912.L.1012.02.IK	100	80	74	12	14	10	30	
01-0446	912.R.1212.02.IK	100	80	74	12	14	12	30	
01-0529	912.L.1212.02.IK	100	80	74	12	14	12	30	
01-0428	912.R.1616.02.IK	100	80	74	16	16	16	34	
01-0570	912.L.1616.02.IK	100	80	74	16	16	16	34	

Abmessungen in mm
Dimensions in mm

Ersatzteile / Spare parts	
004.00.22	4117.R
	4156.L

Weitere Größen auf Anfrage
other sizes on request

Wendepplattenhalter HORN Typ S 274
Turret plate holder HORN type S 274

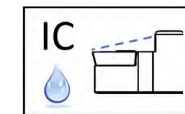

Anwendungsbereich Kopierdrehen, Abstechen
Range of application copy turning, plunging

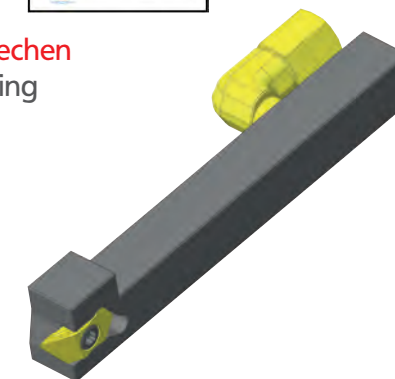
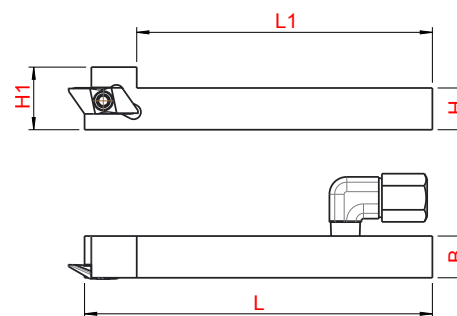

Bestell Nummer Order Number	Bezeichnung Description	L	L1	B	H	B1	für Wendepplatte for insert
01-0522	974.R.1012.04.IK	100	85	10	12	16	HORN Typ S 274
01-0532	974.L.1012.04.IK	100	85	10	12	16	
01-0413	974.R.1212.04.IK	100	85	12	12	18	
01-0414	974.L.1212.04.IK	100	85	12	12	18	
01-0430	974.R.1616.04.IK	100	85	16	16	22	
01-0512	974.L.1616.04.IK	100	85	16	16	22	
01-0438	974.R.2020.04.IK	100	85	20	20	26	
01-0500	974.L.2020.04.IK	100	85	20	20	26	

Abmessungen in mm
Dimensions in mm

Ersatzteile / Spare parts	
004.00.22	001.01.39

Weitere Größen auf Anfrage
other sizes on request

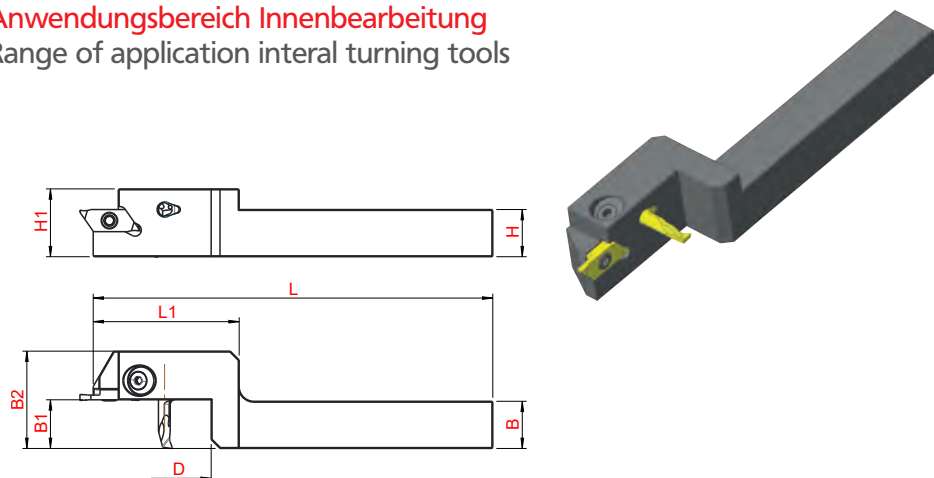

Außen- / Innendrehhalter Typ HORN Typ 105 und S 274
External- / Internal turning holder type HORN type 105 and S 274

Anwendungsbereich Innenbearbeitung
Range of application internal turning tools



Bestell Nummer Order Number	Bezeichnung Description	L	B	H	H1	B1	B2	L1	D	für Wendeplatte for insert
14-0987	AIH.974.R.1212.K04	130	12	12	19	16,5	33	50	30	Horn Typ 105 und S 274
14-0986	AIH.974.R.1616.K04	130	16	16	23	16,5	33	50	30	
14-0367	AIH.974.R.2020.K04	130	20	20	27	16,5	33	55	32	

Abmessungen in mm
Dimensions in mm

Ersatzteile / Spare parts	
	
4.123	001.01.39

Weitere Größen auf Anfrage
other sizes on request

Wendeplattenhalter HORN Typ S 100
Turret plate holder HORN type S 100

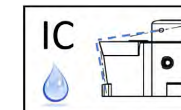

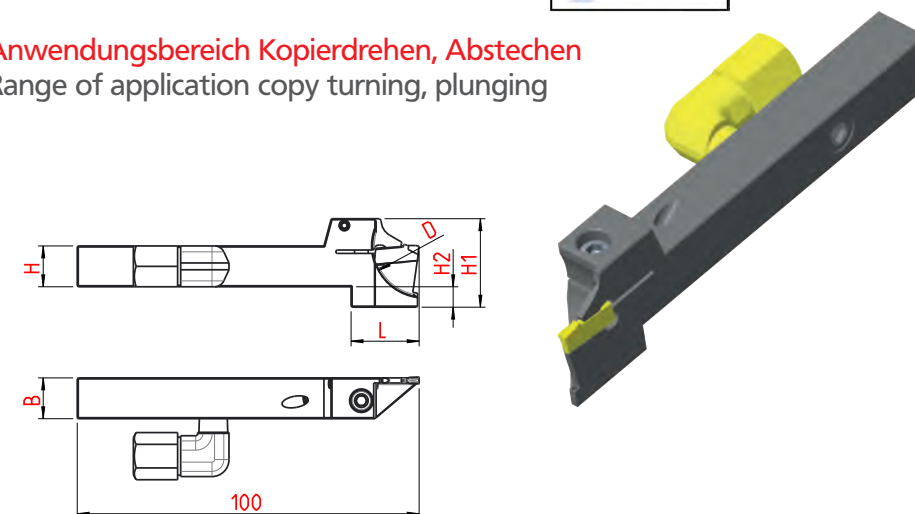

Anwendungsbereich Kopierdrehen, Abstechen
Range of application copy turning, plunging



Bestell Nummer Order Number	Bezeichnung Description	H	B	H1	H2	L	D _{max}	für Wendeplatte for insert
01-1341	910.R.1012.01.2IK	10	12	24	6	20	20	HORN Typ S 100 Größe 01
01-1342	910.L.1012.01.2IK	10	12	24	6	20	20	
01-1339	910.R.1212.01.2IK	12	12	26	6	20	26	
01-1340	910.L.1212.01.2IK	12	12	26	6	20	26	
01-1343	910.R.1616.01.2IK	16	16	34	10	25	42	
01-1344	910.L.1616.01.2IK	16	16	34	10	25	42	

Abmessungen in mm
Dimensions in mm

für Stechbreite 2,0 - 2,2 mm
width of groove 2,0 - 2,2 mm

Ersatzteile / Spare parts	
	
004.00.22	001.01.64

Weitere Größen auf Anfrage
other sizes on request

Wendepplattenhalter HORN Typ S 100
Turret plate holder HORN type S 100

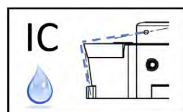

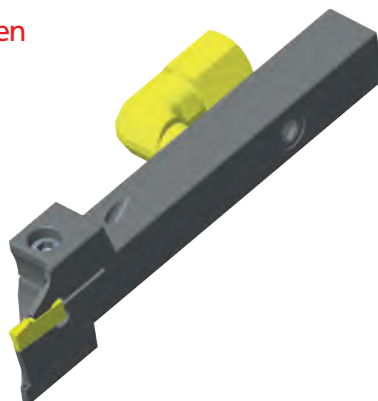
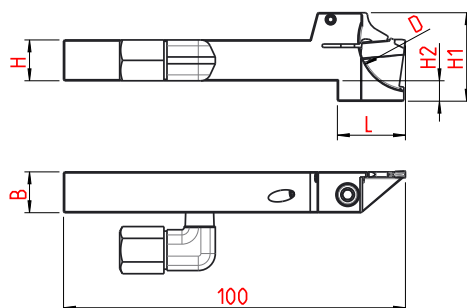

Anwendungsbereich Kopierdrehen, Abstechen
Range of application copy turning, plunging



Bestell Nummer Order Number	Bezeichnung Description	H	B	H1	H2	L	D _{max}	für Wendepplatte for insert
01-1354	910.R.1012.02.2IK	10	12	24	6	20	20	HORN Typ S 100 Größe 02
01-1356	910.L.1012.02.2IK	10	12	24	6	20	20	
01-1352	910.R.1212.02.2IK	12	12	26	6	20	26	
01-1353	910.L.1212.02.2IK	12	12	26	6	20	26	
01-1355	910.R.1616.02.2IK	16	16	34	10	25	42	
01-1357	910.L.1616.02.2IK	16	16	34	10	25	42	

Abmessungen in mm
Dimensions in mm

für Stechbreite 2,5 mm
width of groove 2,5 mm

Ersatzteile / Spare parts	
	
004.00.22	001.01.64

Weitere Größen auf Anfrage
other sizes on request

Wendepplattenhalter HORN Typ S 100
Turret plate holder HORN type S 100

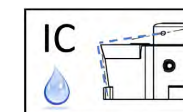

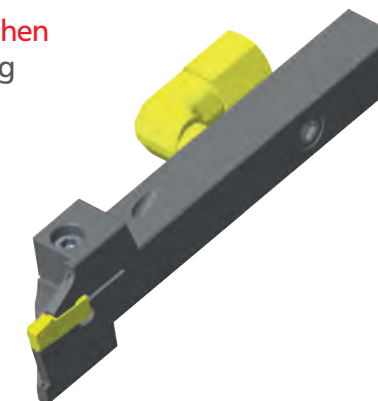
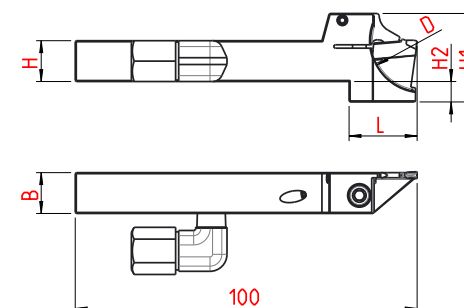

Anwendungsbereich Kopierdrehen, Abstechen
Range of application copy turning, plunging



Bestell Nummer Order Number	Bezeichnung Description	H	B	H1	H2	L	D _{max}	für Wendepplatte for insert
01-1358	910.R.1212.03.2IK	12	12	26	6	20	26	HORN Typ S 100 Größe 03
01-1359	910.L.1212.03.2IK	12	12	26	6	20	26	
01-1362	910.R.1616.03.2IK	16	16	34	10	25	42	
01-1363	910.L.1616.03.2IK	16	16	34	10	25	42	

Abmessungen in mm
Dimensions in mm

für Stechbreite 3,0 mm
width of groove 3,0 mm

Ersatzteile / Spare parts	
	
004.00.22	001.01.64

Weitere Größen auf Anfrage
other sizes on request

Wendepplattenhalter Precitool Typ 615
Turret plate holder Precitool type 615

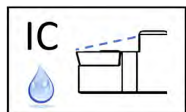

Anwendungsbereich Abstechen, Einstech-Langdrehen
Range of application plunging, grooving

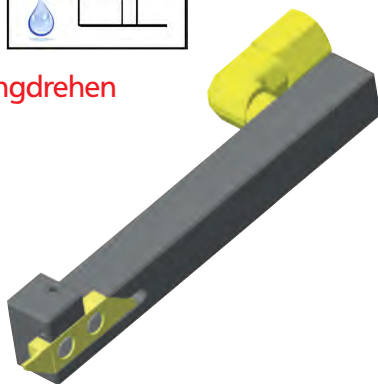
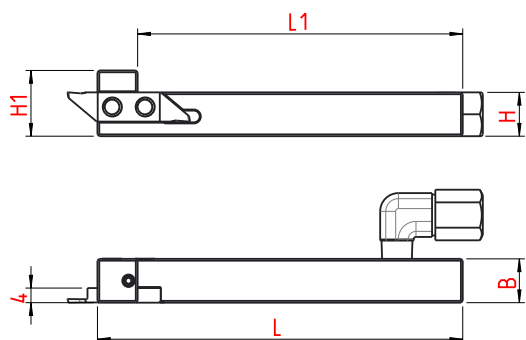

Bestell Nummer Order Number	Bezeichnung Description	L	L1	B	H	H1	für Wendepplatte for insert
01-1360	PR615.1012.R.IK	100	86	10	12	18	Precitool Typ 615
01-1361	PR615.1012.L.IK	100	86	10	12	18	
01-1247	PR615.1212.R.IK	100	86	12	12	18	
01-1255	PR615.1212.L.IK	100	86	12	12	18	
01-1248	PR615.1616.R.IK	100	86	16	16	22	
01-1254	PR615.1616.L.IK	100	86	16	16	22	

Abmessungen in mm
Dimensions in mm

Ersatzteile / Spare parts	
004.00.22	628 V

Weitere Größen auf Anfrage
other sizes on request

Wendepplattenhalter Typ NKT
Turret plate holder type NKT

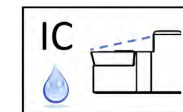

Anwendungsbereich Formstechen
Range of application profiling

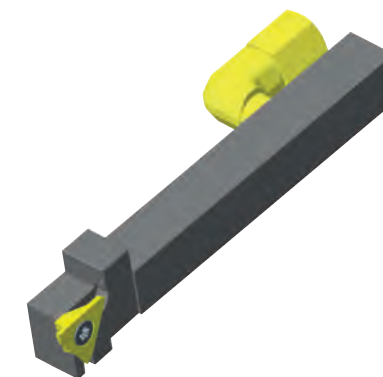
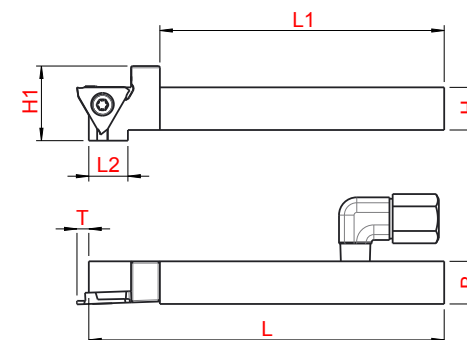

Bestell Nummer Order Number	Bezeichnung Description	L	L1	L2	B	H	T _{max}	H1	für Wendepplatte for insert
01-0148	GTTR.1212.H32.IK	100	80	11	12	12	3	21	NKT Typ GTM.. 32..
01-0489	GTTR.1616.H32.IK	100	80	-	16	16	3	22	

Abmessungen in mm
Dimensions in mm

Ersatzteile / Spare parts	
004.00.22	001.01.27

Weitere Größen auf Anfrage
other sizes on request

Wendepplattenhalter Typ 16ER/16EL
Turret plate holder type 16ER/16EL

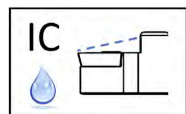

Anwendungsbereich Gewindestrehlen
Range of application copy thread cutting

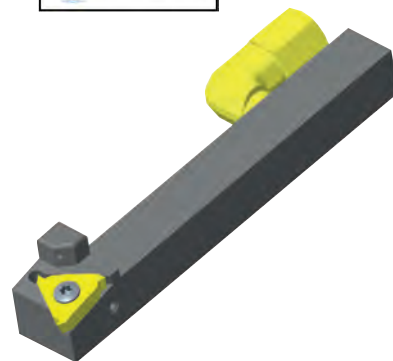
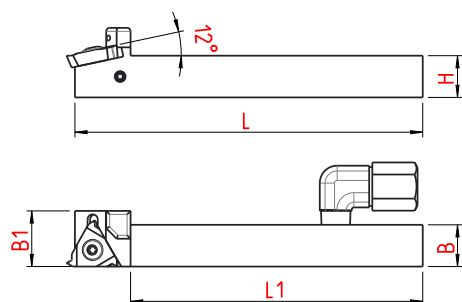

Bestell Nummer Order Number	Bezeichnung Description	L	L1	B	H	B1	für Wendepplatte for insert
01-0126	SER.1012.H16.IK	100	84	12	10	16	16ER 16EL
01-0564	SEL.1012.H16.IK	100	84	12	10	16	
01-0122	SER.1212.H16.IK	100	84	12	12	16	
01-0136	SEL.1212.H16.IK	100	84	12	12	16	
01-0119	SER.1616.H16.IK	100	84	16	16	16	
01-0565	SEL.1616.H16.IK	100	84	16	16	16	

Abmessungen in mm
Dimensions in mm

Wendepplatten siehe Seite 2.17
insert see page 2.17

Ersatzteile / Spare parts	
004.00.22	001.01.65

Weitere Größen auf Anfrage
other sizes on request

Wendepplattenhalter Typ 16ER/16EL
Turret plate holder type 16ER/16EL

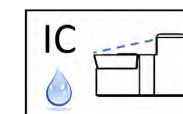

Anwendungsbereich Gewindestrehlen
Range of application copy thread cutting

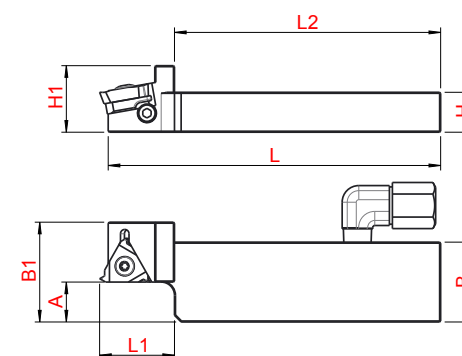

Bestell Nummer Order Number	Bezeichnung Description	L	L1	L2	A	B	H	B1	H1	für Wendepplatte for insert
01-1309	SER.1224.H16.IK.A12	100	22,5	80	12	24	12	30	20	16ER
01-0571	SER.1232.H16.IK.A20	100	22,5	80	20	32	12	38	20	
01-1308	SER.1632.H16.IK.A16	100	22,5	80	16	32	16	35	24	
01-0572	SER.1646.H16.IK.A30	100	22,5	80	30	46	16	49	24	

Abmessungen in mm
Dimensions in mm

Wendepplatten siehe Seite 2.17
insert see page 2.17

Unterlegplatte / Shim						
	3° N	2° N	1° N	0°	1° P	2° P
Art. Nr. R	00200185	00200184	00200183	00200180	00200182	00200181
Art. Nr. L	00200195	00200194	00200193	00200190	00200192	00200191

Berechnung Steigungswinkel auf Seite 4.82 – 4.83, calculation gradient angle see page 4.82 – 4.83

Ersatzteile / Spare parts	
004.00.22	001.01.65

Weitere Größen auf Anfrage
other sizes on request

Wendeplattenhalter Typ CS..
Turret plate holder type CS..

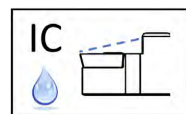

Anwendungsbereich Einstech-Langdrehen
Range of application grooving and turning

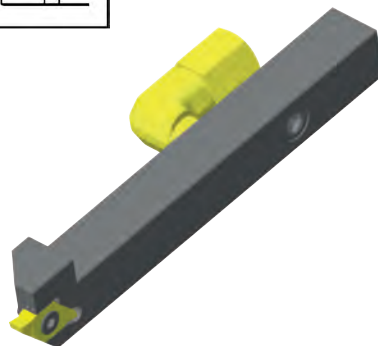
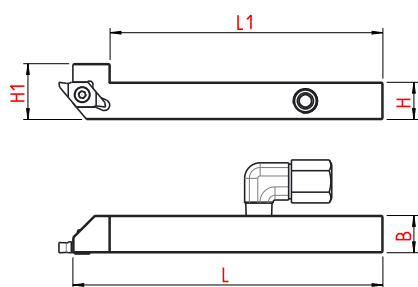

Bestell Nummer Order Number	Bezeichnung Description	L	L1	B	H	H1	für Wendeplatte for insert
01-1349	ANSS.R.1012.H08.IK	100	88	12	10	16	CS 08 / SCD 08
01-1350	ANSS.R.1212.H08.IK	100	88	12	12	18	TP CS 08
01-1351	ANSS.R.1616.H08.IK	100	88	16	16	22	VP CS 08

Abmessungen in mm
Dimensions in mm

Wendeplatten siehe Seite 2.13 – 2.16
insert see page 2.13 – 2.16

Ersatzteile / Spare parts	
004.00.22	001.01.39

Weitere Größen auf Anfrage
other sizes on request

Wendeplattenhalter Typ CS..
Turret plate holder type CS..

Anwendungsbereich Einstech-Langdrehen
Range of application grooving and turning

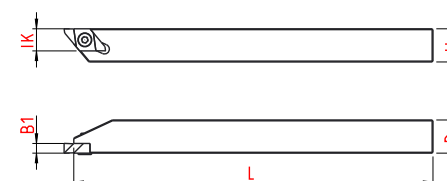

Bestell Nummer Order Number	Bezeichnung Description	L	B	H	B1	IK	für Wendeplatte for insert
01-0037	ANSS.R.1010.K06	130	10	10	2,5	6	CS.06 SCD.06. TP.CS.06 VP.CS.06
01-0027	ANSS.L.1010.K06	130	10	10	2,5	6	
01-0039	ANSS.R.1212.K06	130	12	12	2,5	6	
01-0029	ANSS.L.1212.K06	130	12	12	2,5	6	
01-0038	ANSS.R.1010.K08	130	10	10	3,5	8	CS.08 SCD.08. TP.CS.08 VP.CS.08
01-0028	ANSS.L.1010.K08	130	10	10	3,5	8	
01-0040	ANSS.R.1212.K08	130	12	12	3,5	8	
01-0030	ANSS.L.1212.K08	130	12	12	3,5	8	
01-0043	ANSS.R.1616.K08	130	16	16	3,5	8	
01-0033	ANSS.L.1616.K08	130	16	16	3,5	8	

Abmessungen in mm
Dimensions in mm

Wendeplatten siehe Seite 2.13 – 2.16,
insert see page 2.13 – 2.16

Ersatzteile / Spare parts	
001.01.04 für CS.08	001.01.03 für CS.06

Weitere Größen auf Anfrage
other sizes on request

Wendepplattenhalter Typ CoroCut Turret plate holder type CoroCut

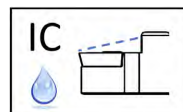

Anwendungsbereich Abstechen Range of application plunging

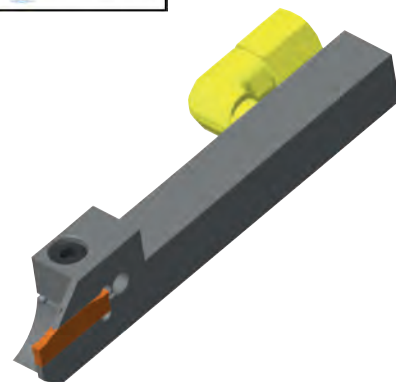
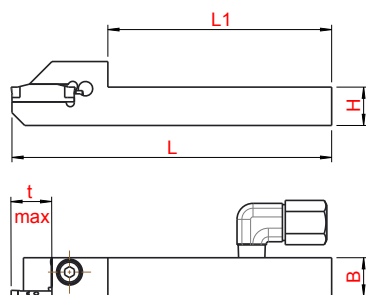

Bestell Nummer Order Number	Bezeichnung Description	L	L1	B	H	t max	für Wendeplatte for insert
01-1264	G.R.F123.E12.1012B.IK	100	70	12	10	12	Sandvik CoroCut 123 Größe E - 2.0
01-1265	G.L.F123.E12.1012B.IK	100	70	12	10	12	
01-0478	G.R.F123.E12.1212B.IK	100	70	12	12	12	
01-0435	G.L.F123.E12.1212B.IK	100	70	12	12	12	
01-0477	G.R.F123.E15.1616B.IK	100	70	16	16	15	
01-0434	G.L.F123.E15.1616B.IK	100	70	16	16	15	
01-0479	G.R.F123.G12.1012B.IK	100	70	12	10	12	Sandvik CoroCut 123 Größe G - 3.0
01-1278	G.L.F123.G12.1012B.IK	100	70	12	10	12	
01-1277	G.R.F123.G12.1212B.IK	100	70	12	12	12	
01-1256	G.L.F123.G12.1212B.IK	100	70	12	12	12	
01-0476	G.R.F123.G12.1616B.IK	100	70	16	16	12	
01-0419	G.L.F123.G12.1616B.IK	100	70	16	16	12	
01-0474	G.R.F123.G15.1616B.IK	100	70	16	16	15	
01-0475	G.L.F123.G15.1616B.IK	100	70	16	16	15	

Abmessungen in mm
Dimensions in mm

Ersatzteile / Spare parts	
004.00.22	001.00.66 M4x12
	001.00.14 M5x16
	001.01.51 M5x14

Weitere Größen auf Anfrage
other sizes on request

RÄNW-Rändel-Werkzeug RÄNW-knurling tool

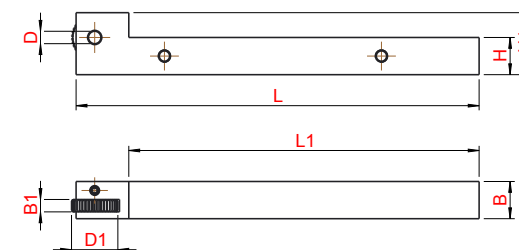

Bestell Nummer Order Number	Bezeichnung Description	L	L1	H	H1	B	B1	D	D1
14-0193	RAENWR.1010.15.4.4	130	102	10	18	10	4	4	15
14-0196	RAENWR.1212.15.4.4	130	113	12	20	12	4	4	15
14-0988	RAENWR.1212.15.5.4	130	113	12	20	12	5	4	15
14-0197	RAENWR.1212.15.5.5	130	113	12	20	12	5	5	15
14-0199	RAENWR.1212.15.6.4	130	109	12	20	12	6	4	15
14-0260	RAENWR.1616.15.4.4	130	113	16	24	16	4	4	15
14-0203	RAENWR.1616.20.6.6	130	106	16	24	16	6	6	20
14-0257	RAENWR.1616.20.8.6	130	106	16	24	16	8	6	20

Abmessungen in mm
Dimensions in mm

Rändelrad siehe Seite 2.18
knurling see page 2.18

Ersatzteile / Spare parts		
für Bestell.Nr.		
14-0193	002.00.28	002.00.123
14-0196	002.00.47	002.00.124
14-0988	002.00.47	002.00.124
14-0197	002.00.47	002.00.144
14-0199	002.00.46	002.00.124
14-0260	002.00.28	002.00.125
14-0203	002.00.46	002.00.133
14-0257	002.00.46	002.00.133

Weitere Größen auf Anfrage
other sizes on request

RÄDW-Rändel-Werkzeug
RÄDW-knurling tool

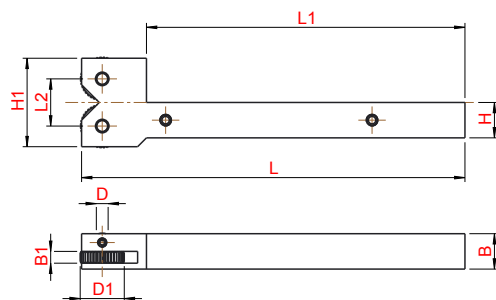

1



Bestell Nummer Order Number	Bezeichnung Description	L	L1	L2	H	H1	B	B1	D	D1
14-0156	RAEDW.R.1010.15.4.4	130	108	16	10	30	10	4	4	15
14-0159	RAEDW.R.1212.15.4.4	130	108	16	12	30	12	4	4	15
14-0196	RAEDW.R.1212.15.6.4	130	108	16	12	30	12	6	4	15

Abmessungen in mm
Dimensions in mm

Rändelrad siehe Seite 2.18
knurling see page 2.18

Ersatzteile / Spare parts		
für Bestell.Nr.		
14-0193	002.00.46	002.00.123
14-0203	002.00.46	002.00.124
14-0257	002.00.46	002.00.133

Weitere Größen auf Anfrage
other sizes on request

BADW Bohr und Ausdrehwerkzeug
BADW-boring tool

1

Anwendungsbereich Bohren / Ausdrehen
Range of application boring tools

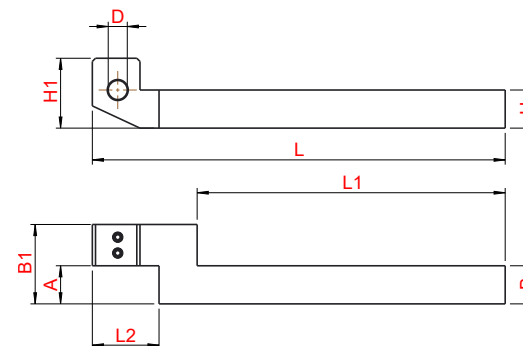

Bezeichnung Description Bestell-Nr.	L	L1	L2	H	H1	B	B1	A	D
BADW.1010.R.12-	130	102	18	10	18	10	25	12	3-6
BADW.1010.R.20-	130	102	18	10	18	10	33	20	3-6
BADW.1212.R.12-	130	97	21	12	22	12	25	12	3-8
BADW.1212.R.20-	130	97	21	12	22	12	33	20	3-8
BADW.1616.R.12-	130	93	25	16	24	16	26	12	3-10
BADW.1616.R.20-	130	91	25	16	25	16	33	20	3-10

Abmessungen in mm
Dimensions in mm

Zentrierbohrer siehe Seite 2.19 – 2.21
centering drills see page 2.19 – 2.21

Ersatzteile / Spare parts	
	
D.Ø 3	002.00.53
D.Ø 3 - Ø 6	002.00.47
D.Ø 6 - Ø 10	002.00.39

Bestellbeispiel / order example:

BADW.1212.R.12.4
Maß A
dimension A

Weitere Größen auf Anfrage
other sizes on request

ZISW N Zentrierbohrerhalter
ZISW N center holder

Anwendungsbereich Zentrieren
Range of application center

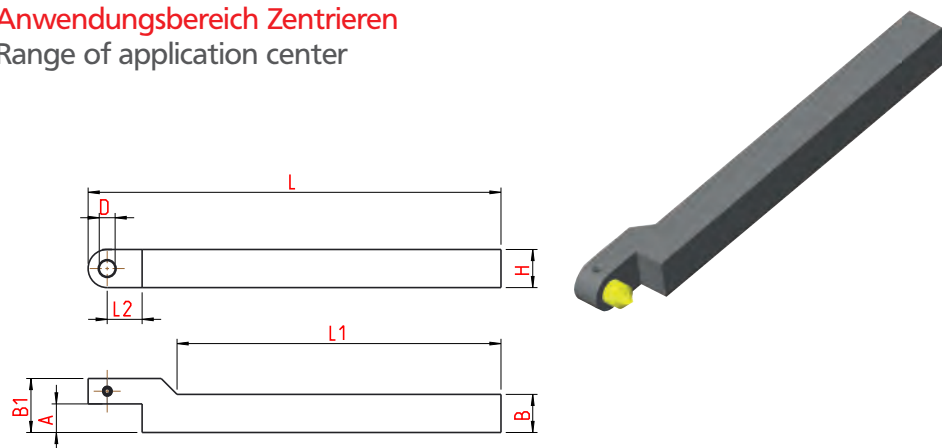

Bezeichnung Description Bestell-Nr.	L	L1	L2	H	B	B1	A	D
ZISW.N.1212.9-	130	102	11	12	12	17	9	3-6
ZISW.N.1212.12-	130	100	11	12	12	20	12	3-6
ZISW.N.1616.12.	130	100	14	16	16	20	12	3-6

Abmessungen in mm
Dimensions in mm

Zentrierbohrer siehe Seite 2.19 – 2.21
centering drills see page 2.19 – 2.21

Bestellbeispiel / order example:

ZISW.N.1212.9.4

Maß A
dimension A

Ersatzteile / Spare parts	
	
D.Ø 3	002.00.53
D.Ø 4 - Ø 6	002.00.45

Weitere Größen auf Anfrage
other sizes on request

ZISW R/L Zentrierbohrerhalter
ZISW R/L center holder

Anwendungsbereich Zentrieren
Range of application center

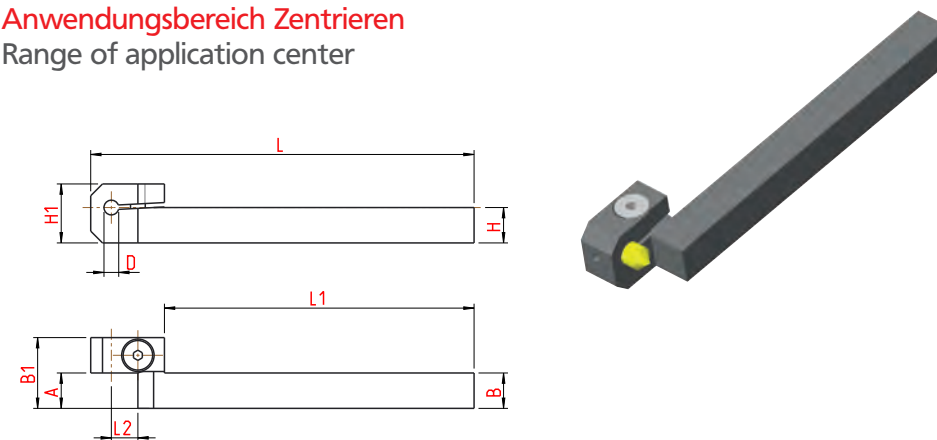

Bezeichnung Description Bestell-Nr.	L	L1	L2	H	H1	B	B1	A	D
ZISW.R/L.0808.9-	130	105	9	8	16	8	22	9	3-6
ZISW.R/L.1010.9-	130	105	9	10	20	10	22	9	3-6
ZISW.R/L.1616.9-	130	105	9	16	26	16	28	9	4-8
ZISW.R/L.1212.12-	130	105	9	12	20	12	24	12	3-6
ZISW.R/L.1616.12-	130	100	10	16	26	16	28	12	4-8
ZISW.R/L.2020.12-	130	98	17	20	30	20	28	12	4-12

Abmessungen in mm
Dimensions in mm

Zentrierbohrer siehe Seite 2.19 – 2.21
centering drills see page 2.19 – 2.21

Bestellbeispiel:

ZISW.R.1212.12.4

Maß A
Durchmesser

Ersatzteile / Spare parts	
	
002.00.47	001.00.64

Weitere Größen auf Anfrage
other sizes on request

INHALTSVERZEICHNIS Wendepplatten

SUMMARY insert

Graf G-Wendepplatten	
Graf G-insert	2.2
CC.. Wendepplatten	
CC.. insert	2.9
DC.. Wendepplatten	
DC.. insert	2.10
VC.. Wendepplatten	
VC.. insert	2.12
CS.. Wendepplatte	
CS.. insert	2.13
16 ER / 16 EL Wendepplatten	
16 ER / 16 EL insert	2.17
Rändel	
Knurl	2.18
Zentrier-Flachbohrer	
Centering flat drill	2.19

Wendepatte Typ G
Insert type G

Einstech-Langdrehen
grooving

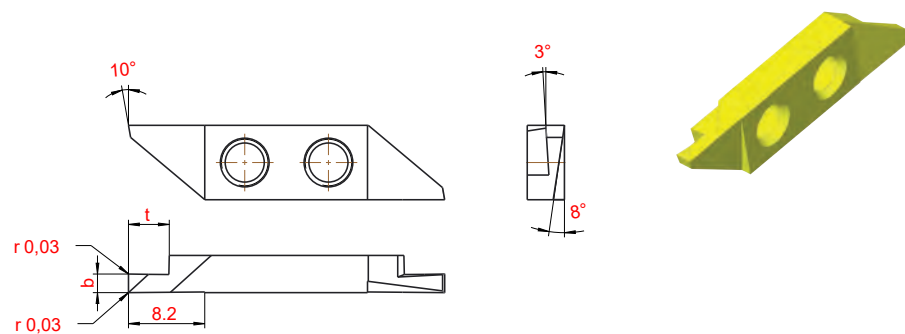

Breite 1,0 - 3,0 mm
width of groove 1,0 - 3,0mm

Bezeichnung Description	b ± 0,02	t + 0,2	G18	TIN	IR3
G.0201.0.R	1,0	2,5	•	•	•
G.0201.5.R	1,5	3,0	•	•	•
G.0202.0.R	2,0	4,0	•	•	•
G.0202.5.R	2,5	5,0	•	•	•
G.0203.0.R	3,0	6,0	•	•	•

Wendepatte Typ G
Insert type G

Einstech-Langdrehen
grooving

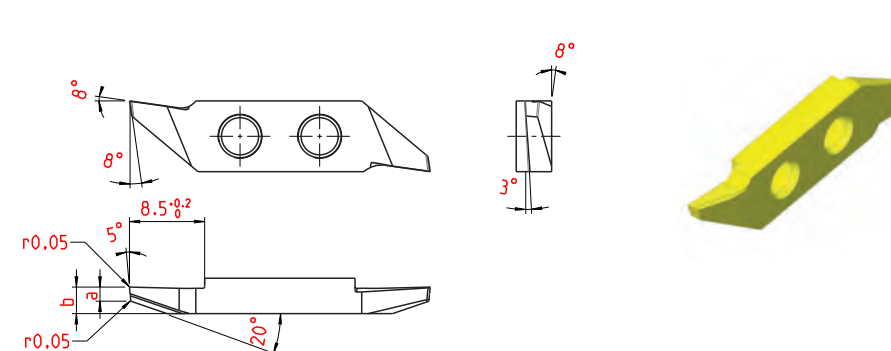

Bezeichnung Description	b ± 0,05	a ± 0,05	G18	TIN	IR3
G.0213.0.R	3,0	2,5	•	•	•
G.0213.5.R	3,5	3,0	•	•	•
G.0214.0.R	4,0	4,0	•	•	•

Wendepatte Typ G
Insert type G

Abstechen
plunging

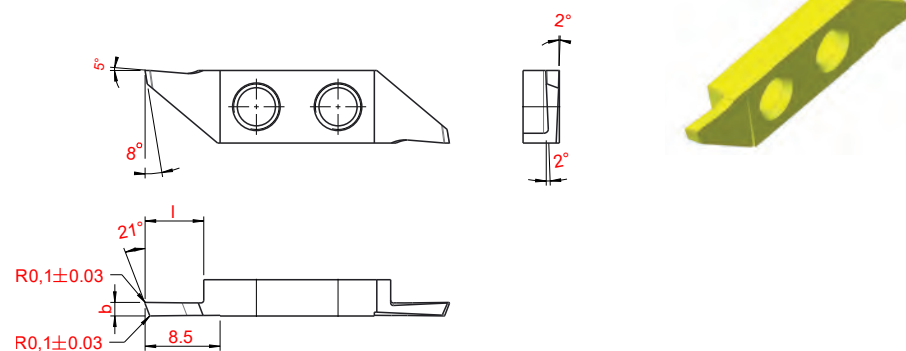

Bezeichnung Description	b ± 0,05	L + 0,2	G18	TIN	IR3
G.1000.7.RF	0,7	3,2	•	•	•
G.1001.0.RF	1,0	5,5	•	•	•
G.1001.5.RF	1,5	6,5	•	•	•
G.1002.0.RF	2,0	8,5	•	•	•

Wendepatte Typ G
Insert type G

Abstechen
plunging

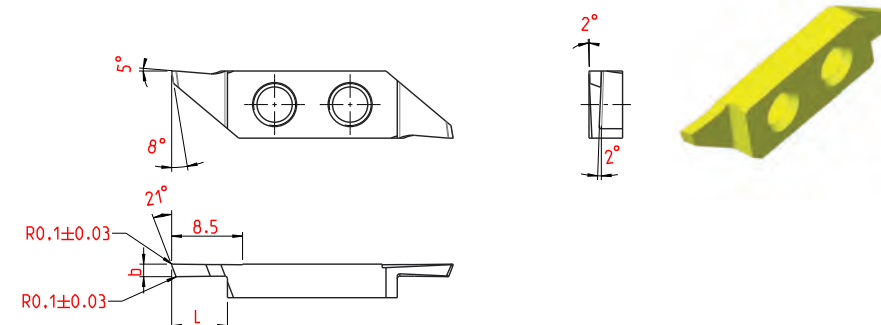

Bezeichnung Description	b ± 0,05	L + 0,2	G18	TIN	IR3
G.1010.7.RA	0,7	3,2	•	•	•
G.1011.0.RA	1,0	5,5	•	•	•
G.1011.5.RA	1,5	6,5	•	•	•
G.1012.0.RA	2,0	8,5	•	•	•

Wendepatte Typ G
Insert type G

Gewindestrehlen Teilprofil
thread cutting partial profile

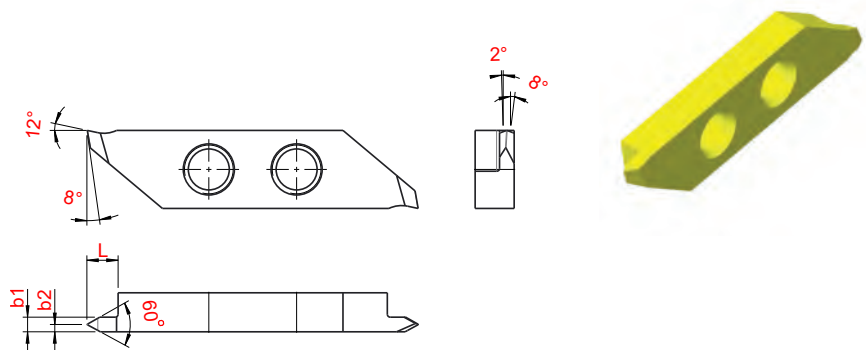
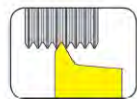

Bezeichnung Description	b1 ± 0,05	b2 ± 0,05	L + 0,2	r	G18	TIN	IR3
TP.G.0501.5.R.60°	1,5	0,75	3,2	0,04	•	•	•
TP.G.0501.5.L.60°	1,5	0,75	3,2	0,04	•	•	•
TP.G.0503.5.R.60°	3,5	1,75	5,2	0,1	•	•	•
TP.G.0503.5.L.60°	3,5	1,75	5,2	0,1	•	•	•

Wendepatte Typ G
Insert type G

Gewindestrehlen Vollprofil
thread cutting full profile

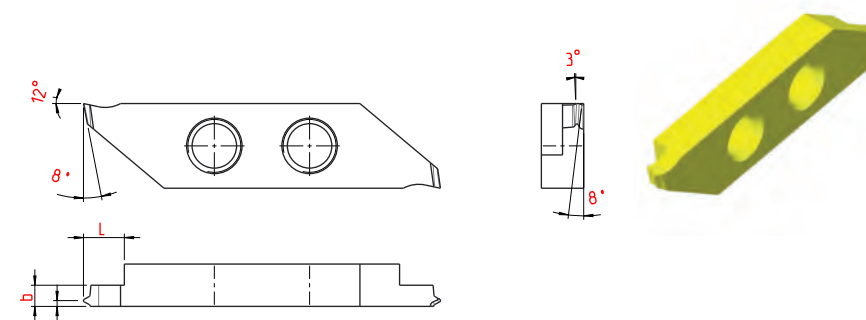

Bezeichnung Description	b ± 0,05	t ± 0,05	L + 0,2	Steigung	G18	TIN	IR3
VP.G.0512.R.0.35.STG	2,0	0,40	4,0	0,35	•	•	•
VP.G.0512.R.0.40.STG	2,0	0,40	4,0	0,40	•	•	•
VP.G.0512.R.0.50.STG	2,0	0,40	4,0	0,50	•	•	•
VP.G.0512.R.0.70.STG	2,0	0,60	4,0	0,70	•	•	•
VP.G.0512.R.0.75.STG	2,0	0,60	4,0	0,75	•	•	•
VP.G.0512.R.0.80.STG	2,0	0,60	4,0	0,80	•	•	•
VP.G.0512.R.1.0.STG	2,0	0,70	4,0	1,00	•	•	•
VP.G.0512.R.1.25.STG	2,0	0,90	4,0	1,25	•	•	•
VP.G.0512.R.1.50.STG	2,0	1,00	4,0	1,50	•	•	•

Wendepatte Typ G Insert type G

Formstechen profiling

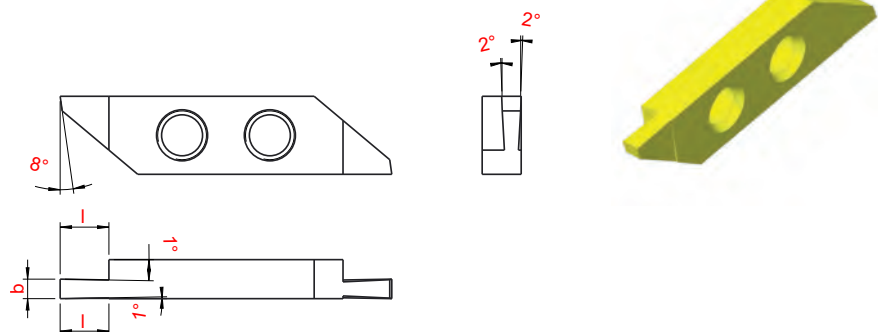

Bezeichnung Description	b ± 0,03	L + 0,2	G18	TIN	IR3
G.0301.0.R	1,0	4	•	•	•
G.0301.5.R	1,5	5,0	•	•	•
G.0302.0.R	2,0	5,5	•	•	•
G.0302.5.R	2,5	6,0	•	•	•
G.0303.0.R	3,0	8,0	•	•	•

Wendepatte Typ CC.. Insert type CC..

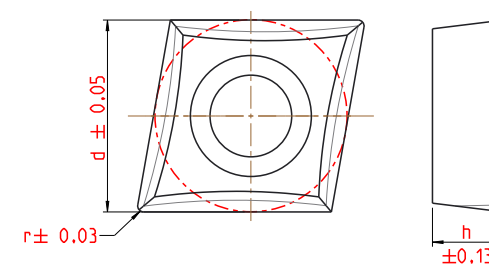

Bezeichnung Description	d	r	h	K10	TIN	IR3
CCGT.06.02.02.GA10	6,35	0,20	2,38	•	•	•
CCGT.06.02.04.GA10	6,35	0,40	2,38	•	•	•
CCGT.09.T3.02.GA10	9,52	0,20	3,97	•	•	•
CCGT.09.T3.04.GA10	9,52	0,40	3,97	•	•	•

Wendepatte Typ DC..
Insert type DC..

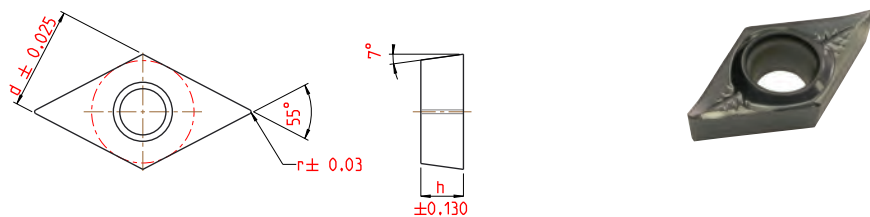

Bezeichnung Description	d	r	h	K10	TIN	PVD
DCGT.07.02.02.GA10	6,35	0,20	2,38	•	•	•
DCGT.07.02.04.GA10	6,35	0,40	2,38	•	•	•
DCGT.11.T3.02.GA10	9,52	0,20	3,97	•	•	•
DCGT.11.T3.04.GA10	9,52	0,40	3,97	•	•	•

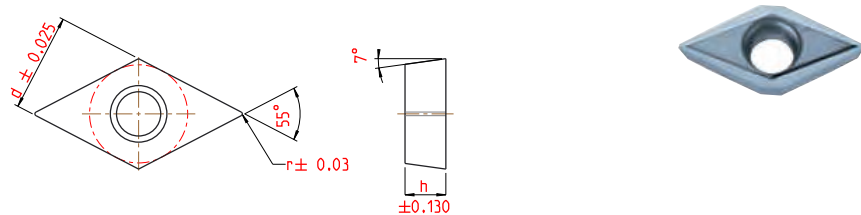

Bezeichnung Description	d	r	h	K10	TIN	PVD
DCGT.07.02.02.G.FN60	6,35	0,20	2,38	•	•	•
DCGT.07.02.04.G.FN60	6,35	0,40	2,38	•	•	•
DCGT.11.T3.02.G.FN60	9,52	0,20	3,97	•	•	•
DCGT.11.T3.04.G.FN60	9,52	0,40	3,97	•	•	•

Wendepatte Typ DC..
Insert type DC..

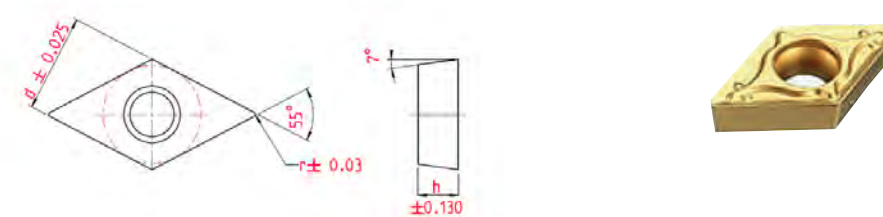

Bezeichnung Description	d	r	h	TIN
DCGT.07.02.005.G.C50	6,35	0,05	2,38	•
DCGT.07.02.01.G.C50	6,35	0,10	2,38	•
DCGT.11.T3.01.G.C50	9,52	0,10	3,97	•

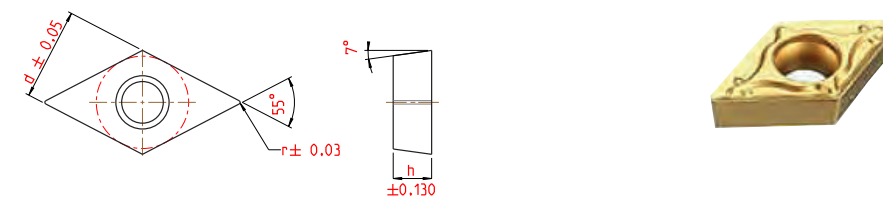

Bezeichnung Description	d	r	h	TIN
DCMT.07.02.02.G.C50	6,35	0,20	2,38	•
DCMT.07.02.04.G.C50	6,35	0,40	2,38	•
DCMT.11.T3.02.G.C50	9,52	0,20	3,97	•
DCMT.11.T3.04.G.C50	9,52	0,40	3,97	•

Wendepatte Typ VC..
Insert type VC..

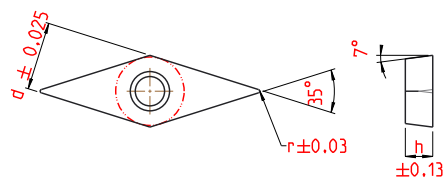

Bezeichnung Description	d	r	h	K10	TIN	PVD
VCGT.11.03.01.GA10	6,35	0,10	3,18	•	•	•
VCGT.11.03.02.GA10	6,35	0,20	3,18	•	•	•
VCGT.11.03.04.GA10	6,35	0,40	3,18	•	•	•
VCGT.13.03.02.GA10	7,94	0,20	3,18	•	•	•
VCGT.13.03.04.GA10	7,94	0,40	3,18	•	•	•
VCGT.16.04.02.GA10	9,52	0,20	4,76	•	•	•
VCGT.16.04.04.GA10	9,52	0,40	4,76	•	•	•

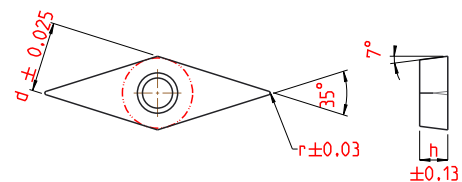

Bezeichnung Description	d	r	h	K10	TIN	PVD
VCGT.11.03.01.GM.05	6,35	0,08	3,18	•	•	•
VCGT.11.03.02.GM.05	6,35	0,18	3,18	•	•	•
VCGT.11.03.04.GM.05	6,35	0,38	3,18	•	•	•
VCGT.16.04.04.GM.05	9,52	0,38	4,76	•	•	•

Wendepatte Typ CS..
Insert type CS..

Einstech-Langdrehen
grooving

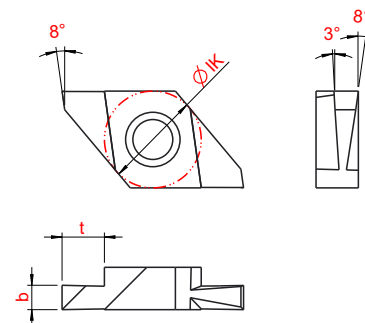

Breite 1,5 - 3,0 mm, width of groove 1,5 - 3,0mm

Bezeichnung Description	b ± 0,02	t + 0,2	IK	G18	TIN	IR3	IR3
SCD.06.150.R	1,5	2,5	6	•	•	•	•
SCD.06.200.R	2,0	2,5	6	•	•	•	•
SCD.06.250.R	2,5	2,5	6	•	•	•	•
SCD.08.200.R	2,0	3,5	8	•	•	•	•
SCD.08.250.R	2,5	3,5	8				•
SCD.08.350.R	3,5	3,5	8	•	•	•	•

Wendeplatte Typ CS..
Insert type CS..

Gewindestreihen Teilprofil
thread cutting partial profile

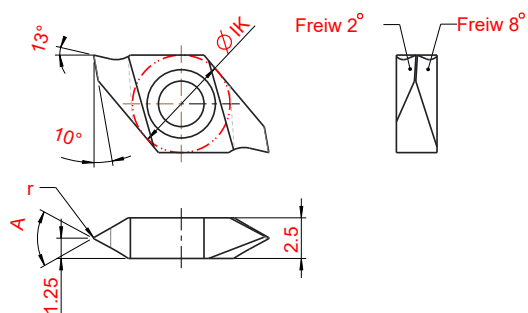
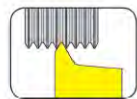

Bezeichnung Description	A	IK	r	G18	TIN	IR3	IR3
TP.CS.06.R.55°	55°	6,0	0,04	•	•	•	•
TP.CS.06.L.55°	55°	6,0	0,04	•	•	•	•
TP.CS.06.R.60°	60°	6,0	0,04	•	•	•	•
TP.CS.06.L.60°	60°	6,0	0,04	•	•	•	•

Wendeplatte Typ CS..
Insert type CS..

Gewindestreihen Vollprofil
thread cutting full profile

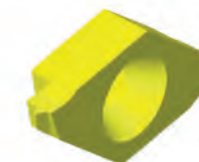
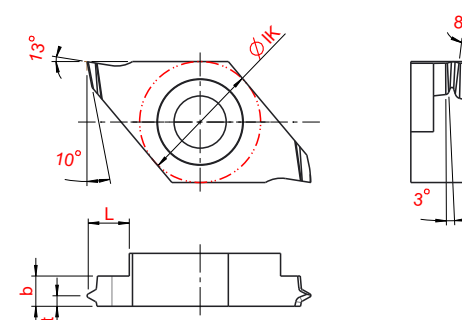

Bezeichnung Description	b ± 0,05	t ± 0,05	L + 0,2	IK	Steigung	G18	TIN	IR3
VP.CS06.0,25.STG.R	1,3	0,30	2,5	6,0	0,25	•	•	•
VP.CS06.0,30.STG.R	1,3	0,30	2,5	6,0	0,30	•	•	•
VP.CS06.0,35.STG.R	1,3	0,40	2,5	6,0	0,35	•	•	•
VP.CS06.0,40.STG.R	1,3	0,40	2,5	6,0	0,40	•	•	•
VP.CS06.0,50.STG.R	1,3	0,40	2,5	6,0	0,50	•	•	•
VP.CS06.0,60.STG.R	1,3	0,60	2,5	6,0	0,60	•	•	•
VP.CS06.0,70.STG.R	1,3	0,60	2,5	6,0	0,70	•	•	•
VP.CS06.0,75.STG.R	1,3	0,60	2,5	6,0	0,75	•	•	•
VP.CS06.0,80.STG.R	1,3	0,60	2,5	6,0	0,80	•	•	•
VP.CS06.1,00.STG.R	1,6	0,70	2,5	6,0	1,00	•	•	•

Wendeplatte Typ CS..
Insert type CS..

Gewindestreihen Vollprofil
thread cutting full profile

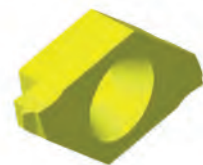
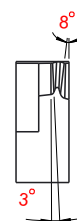
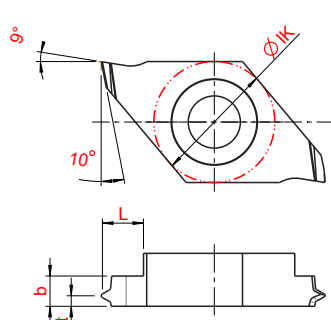

Wendeplatte Typ 16 ER..
Insert type 16 ER..

Gewindestreihen Vollprofil
thread cutting full profile

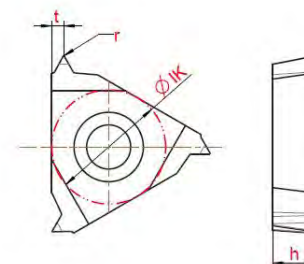

Bezeichnung Description	b ± 0,05	t ± 0,05	L + 0,2	IK	Steigung	G18	TIN	IR3
VP.CS08.0,35.STG.R	1,3	0,40	2,8	8,0	0,35	•	•	•
VP.CS08.0,40.STG.R	1,3	0,40	2,8	8,0	0,40	•	•	•
VP.CS08.0,50.STG.R	1,3	0,40	2,8	8,0	0,50	•	•	•
VP.CS08.0,70.STG.R	1,6	0,60	2,8	8,0	0,70	•	•	•
VP.CS08.0,75.STG.R	1,6	0,60	2,8	8,0	0,75	•	•	•
VP.CS08.0,80.STG.R	1,6	0,60	2,8	8,0	0,80	•	•	•
VP.CS08.1,00.STG.R	2,0	0,70	2,8	8,0	1,00	•	•	•
VP.CS08.1,25.STG.R	2,2	0,90	2,8	8,0	1,25	•	•	•
VP.CS08.1,50.STG.R	2,2	1,00	2,8	8,0	1,50	•	•	•

Bezeichnung Description	r	t	IK	Steigung	h	G18	TIN	IR3
VP16.ER.0.50.ISO	0,08	0,80	9,525	0,50	3,47	•	•	•
VP16.ER.0.75.ISO	0,11	0,80	9,525	0,75	3,47	•	•	•
VP16.ER.0.80.ISO	0,11	0,80	9,525	0,80	3,47	•	•	•
VP16.ER.1.00.ISO	0,14	0,80	9,525	1,00	3,47	•	•	•
VP16.ER.1.25.ISO	0,17	0,80	9,525	1,25	3,47	•	•	•
VP16.ER.1.50.ISO	0,22	0,80	9,525	1,50	3,47	•	•	•
VP16.ER.1.75.ISO	0,25	1,20	9,525	1,75	3,47	•	•	•
VP16.ER.2.00.ISO	0,29	1,20	9,525	2,00	3,47	•	•	•

Rändelrad knurling

Rändelform:
knurled shape:

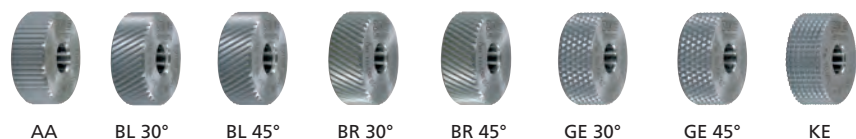

Anwendungsbereich
Rändelwerkzeug
Range of application
knurling

Rändelrad größen:
knurling wheel sizes:

d1 x b1 x d2	d1 x b1 x d2/d5
10 x 4 x 4	15 x 6 x 6/8
12 x 4 x 4	20 x 8 x 10/12
15 x 4 x 4	
15 x 5 x 5	
20 x 6 x 6	
20 x 8 x 6	

Beispiele / Examples:

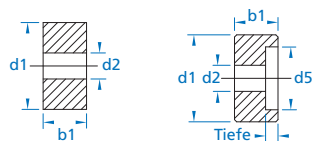

Mögliche Teilungen:
possible pitch:

0,3 / 0,4 / 0,5 / 0,6 / 0,7 / 0,8 / 0,9 / 1,0 / 1,2 / 1,5 / 1,6 / 1,8 / 2,0

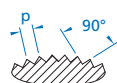

Rändelrad Varianten:
knurling wheel types:

Nr.10 gefräst mit Fase HSS / milled with chamfer HSS
Nr.12 gefräst ohne Fase HSS / milled without chamfer HSS
Nr.11 gefräst mit Fase PM / milled with chamfer PM
Nr.13 gefräst ohne Fase PM / milled without chamfer PM
Nr.30 geschliffen mit Fase PM / ground with chamfer PM
Nr.32 geschliffen ohne Fase PM / ground without chamfer PM
Nr.50 geschliffen mit Fase HM / ground with chamfer HM
Nr.52 geschliffen ohne Fase HM / ground without chamfer HM

HSS = Schnellarbeitsstahl / High Speed Steel
PM = Pulvermetallurgischer Stahl / Powder metallurgical steel
HM = Hartmetall / Hard metal

Bestellbeispiel: Nr.11 gefräst mit Fase PM - BL30 - 15x5x5 - 1,0
Order Example: Nr.11 milled with chamfer PM - BL30 - 15x5x5 - 1,0

Preis auf Anfrage / Preis on request

Zentrierbohrer Centering drills

Bestell-Nr. / Part.-Nr. linke Ausführung / left version	A	D	L	Bestell-Nr. / Part.-Nr. rechte Ausführung / right version
A 1200 - 313	90°	3	13	A 2200 - 313
A 1200 - 317	90°	3	17	A 2200 - 317
A 1200 - 338	90°	3	38	A 2200 - 338
A 1200 - 440	90°	4	40	A 2200 - 440
A 1200 - 550	90°	5	50	A 2200 - 550
A 1200 - 650	90°	6	50	A 2200 - 650
A 1200 - 858	90°	8	58	A 2200 - 858
A 1200 - 1066	90°	10	66	A 2200 - 1066
A 1200 - 1273	90°	12	73	A 2200 - 1273

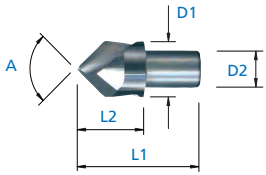
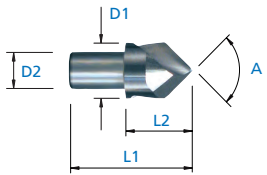
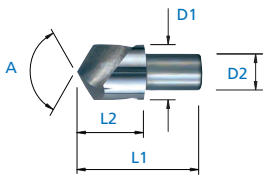
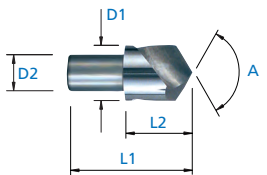

Zentrierbohrer
Centering drills

2

Bestell-Nr. / Part.-Nr. linke Ausführung / left version	A	D1	D2	L1	L2	Bestell-Nr. / Part.-Nr. rechte Ausführung / right version
						
A 1500 - 5 MD	90°	5	4	17	8	A 2520 - 5 MD
A 1500 - 7 MD	90°	7	5	17	8	A 2520 - 7 MD
A 1500 - 10 MD	90°	10	6	22	10	A 2520 - 10 MD
A 1500 - 12 MD	90°	12	8	26	12	A 2520 - 12 MD
						
A 1510 - 5 MD	120°	5	4	17	8	A 2530 - 5 MD
A 1510 - 7 MD	120°	7	5	17	8	A 2530 - 7 MD
A 1510 - 10 MD	120°	10	6	22	10	A 2530 - 10 MD
A 1510 - 12 MD	120°	12	8	26	12	A 2530 - 12 MD

Zentrierbohrer
Centering drills

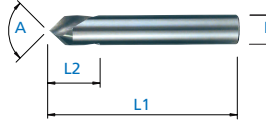
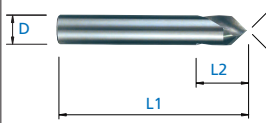
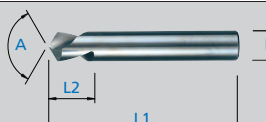
2

Bestell-Nr. / Part.-Nr. linke Ausführung / left version	A	D	L1	L2	Bestell-Nr. / Part.-Nr. rechte Ausführung / right version
					
A 1680 - 2 - 90 MD	90°	2	38	8	A 2680 - 2 - 90 MD
A 1680 - 2,5 - 90 MD	90°	2,5	38	8	A 2680 - 2,5 - 90 MD
A 1680 - 3 - 90 MD	90°	3	38	10	A 2680 - 3 - 90 MD
A 1680 - 4 - 90 MD	90°	4	50	12	A 2680 - 4 - 90 MD
A 1680 - 5 - 90 MD	90°	5	50	15	A 2680 - 5 - 90 MD
A 1680 - 6 - 90 MD	90°	6	57	16	A 2680 - 6 - 90 MD
A 1680 - 8 - 90 MD	90°	8	63	20	A 2680 - 8 - 90 MD
A 1680 - 10 - 90 MD	90°	10	72	22	A 2680 - 10 - 90 MD
A 1680 - 12 - 90 MD	90°	12	73	24	A 2680 - 12 - 90 MD
A 1680 - 16 - 90 MD	90°	16	82	26	A 2680 - 16 - 90 MD
A 1680 - 20 - 90 MD	90°	20	92	30	A 2680 - 20 - 90 MD
					
A 1680 - 2 - 120 MD	120°	2	38	8	A 2680 - 2 - 120 MD
A 1680 - 2,5 - 120 MD	120°	2,5	38	8	A 2680 - 2,5 - 120 MD
A 1680 - 3 - 120 MD	120°	3	38	10	A 2680 - 3 - 120 MD
A 1680 - 4 - 120 MD	120°	4	50	12	A 2680 - 4 - 120 MD
A 1680 - 5 - 120 MD	120°	5	50	15	A 2680 - 5 - 120 MD
A 1680 - 6 - 120 MD	120°	6	57	16	A 2680 - 6 - 120 MD
A 1680 - 8 - 120 MD	120°	8	63	20	A 2680 - 8 - 120 MD
A 1680 - 10 - 120 MD	120°	10	72	22	A 2680 - 10 - 120 MD
A 1680 - 12 - 120 MD	120°	12	73	24	A 2680 - 12 - 120 MD
A 1680 - 16 - 120 MD	120°	16	82	26	A 2680 - 16 - 120 MD
A 1680 - 20 - 120 MD	120°	20	92	30	A 2680 - 20 - 120 MD

INHALTSVERZEICHNIS NACH ANWENDUNG
SUMMARY AFTER APPLICATION

Grundhalter	
Basic holder	3.7
Zwischenstücke	
Plate between	3.15
Innenbearbeitung / Internal Processing	
Halter für Spannzangen	
Holder for collet chuck	3.18
Halter für zylindrische Rundschaft-Werkzeuge	
Holder for cylindrical round shank tools	3.24
Halter für HORN Schneidplatten Typ 105	
Holder for HORN inserts type 105	3.26
Halter für Holler Schneidplatten	
Holder for Holler inserts	3.35
Halter für Picco Schneidplatten	
Holder for Picco inserts	3.39
Mehrfachbearbeitungshalter	
Multiple back working tools	3.43
Kopierdrehen / Copy turning	
Halter für / holder for	
Platte / insert DC..07 02..	3.50
Platte / insert DC..11 T3..	3.55
Platte / insert YW..11 T2..	3.66
Platte / insert VB..11 03.. ..	3.67
Platte / insert VC..11 03.. ..	3.68
Platte / insert VC..13 03.. ..	3.82
Platte / insert VC..16 04.. ..	3.90
Platte / Insert VP..10 03.. ..	3.91

INHALTSVERZEICHNIS NACH ANWENDUNG SUMMARY AFTER APPLICATION

Lang- und Axialdrehen /Turning and Face grooving Halter für / holder for

Platte / insert Applitec Typ 300	3.92
Platte / insert CC..06 02..	3.95
Platte / insert CC..09 T3..	3.100
Platte / insert CN..12 04..	3.103
Platte / insert WN..06 04..	3.104
Platte / insert SC..06 02..	3.105
Platte / insert TC..	3.106
Platte / insert TP..	3.108
Platte / insert TN..	3.109

Formstechen / Gewindedrehen / Einstecken-Langdrehen Forming /grooving / turning / threading Halter für / holder for

Platte / insert ER 16../EL 16	3.110
Platte / insert HORN Typ 274	3.115
Einsatz für QER-12 (Quad-Cut)	3.119
Platte / insert HORN Typ 312	3.121
Platte / insert HORN Typ 315	3.129
Platte / insert SCD/CSX/CS/VP CS/TP CS	3.131
Platte / insert GTMH 32	3.134
Platte / insert GRAF Typ G 02/ G 03/ G 04/ TPG/ VPG	3.135
Platte / insert APPLITEC Typ 700	3.136
Platte / insert Precitod Typ 615	3.138

Halter Vierkantschaft

holder for square shank	3.139
-------------------------------	-------

Höheneinstellvorrichtung HVR

Device for height adjusting HVR	3.140
---------------------------------------	-------

INHALTSVERZEICHNIS NACH BEZEICHNUNG SUMMARY AFTER DESCRIPTION

Rückseitenwerkzeug / Back working tool	Art.Nr. / Art.no.	Halter für / holder for	Seite/ Page
L.01 / R.01	12-0023 / 12-0022	DC.. 07 02..	3.51
L.01.IK / R.01.IK	12-0161 / 12-0160	DC.. 07 02..	3.52
L.02 / R.02	12-0025 / 12-0024	VC.. 11 03..	3.68
L.02.IK / R.02.IK	12-1310 / 12-1309	VC.. 11 03..	3.69
L.02.XL / R.02.XL	12-1312 / 12-1311	VC.. 11 03..	3.70
L.03 / R.03	12-0027 / 12-0026	TP.. 11 03..	3.108
L.04 / R.04	12-0029 / 12-0028	SC.. 06 02..	3.105
L.05 / R.05	12-0031 / 12-0030	SCD/CS/TP CS 08..	3.132
N.06.1010 / N.06.1212	12-0032 / 12-1080		3.139
N.07	12-0033	Zange ER16	3.20
N.07.IK	12-0055	Zange ER16	3.21
N.09	12-0155	Horn 105	3.26
N.09.IK	12-0154	Horn 105	3.27
N.09.S	12-ff	Horn 105	3.28
N.09.S.IK	12-ff	Horn 105	3.29
N.10	12-0037	-	3.43
N.11.A	12-0038	-	3.45
N.11.B	12-0053	-	3.46
N.12.A	12-0509	-	3.47
N.12.B	12-0510	-	3.48
L.13 / R.13	12-0040 / 12-0039	DC.. 11 T3..	3.61
L.13.IK / R.13.IK	12-1213 / 12-1212	DC.. 11 T3..	3.62
L.13.XL / R.13.XL	12-1308 / 12-1307	DC.. 11 T3..	3.63
L.14 / R.14	12-0042 / 12-0041	DC.. 11 T3..	3.55
L.14.IK / R.14.IK	12-0143 / 12-0142	DC.. 11 T3..	3.56
L.15 / R.15	12-0044 / 12-0043	VC.. 11 03..	3.72
L.16 / R.16	12-0046 / 12-0045	16EL / 16ER	3.111
L.16.IK / R.16.IK	12-0148 / 12-0147	16EL / 16ER	3.112
L.17 / R.17	12-0378 / 12-0377	VC.. 13 03..	3.83
L.17.IK / R.17.IK	12-0146 / 12-0145	VC.. 13 03..	3.84
L.18 / R.18	12-0048 / 12-0047	GTMH 32	3.134
N.19	12-0049	DC.. 11 T3..	3.64
N.19.IK	12-0052	DC.. 11 T3..	3.65
L.20 / R.20	12-0821 / 12-0820	SCD/CS/TP CS 08..	3.133
L.28 / R.28	12-1383 / 12-1382	VC.. 11 03..	3.71

INHALTSVERZEICHNIS NACH BEZEICHNUNG SUMMARY AFTER DESCRIPTION

Rückseitenwerkzeug / Back working tool	Art.Nr. / Art.no.	Halter für / holder for	Seite/ Page
L.29 / R.29	12-0262 / 12-0261	VC.. 13 03..	3.87
L.29.IK / R.29.IK	12-1067 / 12-1066	VC.. 13 03..	3.88
N.30	12-ff	ØD4 - ØD16	3.24
N.30.IK	12-ff	ØD6 - ØD16	3.25
N.31	12-0798	3-Fach	3.44
L.34 / R.34	12-1017 / 12-1016	DC.. 11 T3..	3.59
L.35 / R.35	12-0344 / 12-0330	VC.. 13 03..	3.86
L.36 / R.36	12-0407 / 12-0359	CC.. 09 T3..	3.100
L.37 / R.37	12-0452 / 12-0449	VC.. 16 04..	3.90
N.38	12-0478	VC.. 11 03..	3.80
N.38.IK	12-0480	VC.. 11 03..	3.81
L.39 / R.39	12-0479 / 12-0451	TC.. 11 02..	3.106
L.40.IK / R.40.IK	12-1431 / 12-1430	VC.. 11 03..	3.79
N.41	12-0450	ER20	3.22
N.41.IK	12-0469	ER20	3.23
L.42 / R.42	12-0466 / 12-0461	GRAF G0004	3.135
L.43 / R.43	12-0465 / 12-0453	CC.. 09 T3..	3.101
L.43.IK / R.43.IK	12-0503 / 12-0490	CC.. 09 T3..	3.102
L.44 / R.44	12-0512 / 12-0454	QER-12..	3.120
L.45 / R.45	12-1433 / 12-1432	CS/SCD/TP CS 06..	3.131
L.48 / R.48	12-0483 / 12-0467	CC.. 06 02..	3.96
L.48.IK / R.48.IK	12-1152 / 12-0549	CC.. 06 02..	3.97
L.49 / R.49	12-1158 / 12-0468	QER-12..	3.119
L.50 / R.50	12-0516 / 12-0499	CC.. 06 02..	3.98
L.50.IK / R.50.IK	12-1154 / 12-1153	CC.. 06 02..	3.99
L.53 / R.53	12-0335 / 12-0333	VC.. 13 03..	3.85
L.54.IK / R.54.IK	12-1314 / 12-1313	WN.. 06 04..	3.104
N.56.30.IK	12-0470	Holler ØD 3.0	3.35
N.56.45.IK	12-0471	Holler ØD 4.5	3.36
N.56.55.IK	12-0472	Holler ØD 5.5	3.37
N.56.70.IK	12-0473	Holler ØD 7.0	3.38
L.59 / R.59	12-0477 / 12-0476	DC.. 07 02..	3.50
L.60 / R.60	12-1149 / 12-0482	VC.. 11 03..	3.77
L.62 / R.62	12-0500 / 12-0484	VC.. 11 03..	3.75
L.62.IK / R.62.IK	12-0530 / 12-0529	VC.. 11 03..	3.76

INHALTSVERZEICHNIS NACH BEZEICHNUNG SUMMARY AFTER DESCRIPTION

Rückseitenwerkzeug / Back working tool	Art.Nr. / Art.no.	Halter für / holder for	Seite/ Page
L.63 / R.63	12-0086 / 12-0485	VC.. 11 03..	3.78
L.64 / R.64	12-0496 / 12-0486	Horn 312	3.121
L.64.IK / R.64.IK	12-0504 / 12-0501	Horn 312	3.122
L.65 / R.65	12-0497 / 12-0487	Horn 312	3.123
L.65.IK / R.65.IK	12-0505 / 12-0502	Horn 312	3.124
L.66.03 / R.66.03	12-1436 / 12-1435	Horn 315	3.129
L.66.05 / R.66.05	12-1438 / 12-1437	Horn 315	3.130
N.67	12-1061	Horn 312	3.127
N.68	12-0498	Horn 312	3.128
L.69 / R.69	12-1036 / 12-0513	Applitec 300	3.94
L.70 / R.70	12-1043 / 12-0514	Applitec 300	3.92
L.70.IK / R.70.IK	12-0520 / 12-0515	Applitec 300	3.93
L.71 / R.71	12-0061 / 12-0060	VB.. 11 03..	3.67
L.72 / R.72	12-0064 / 12-0063	DC.. 11 T3..	3.57
L.72.IK / R.72.IK	12-1167 / 12-1166	DC.. 11 T3..	3.58
N.73	12-0156	Horn 105	3.30
N.73.IK	12-0158	Horn 105	3.31
N.73.S.IK	12-ff	Horn 105	3.32
L.74 / R.74	12-0519 / 12-0518	Applitec L730/R740	3.136
L.75 / R.75	12-0067 / 12-066	DC.. 07 02..	3.53
L.75.IK / R.75.IK	12-1381 / 12-1380	DC.. 07 02..	3.54
L.76 / R.76	12-1104 / 12-0096	Horn S274	3.115
L.76.IK / R.76.IK	12-1075 / 12-0072	Horn S274	3.117
L.77 / R.77	12-0070 / 12-0071	16EL / 16ER	3.110
N.79	12-1071	Horn 110	3.33
N.79.IK	12-0157	Horn 110	3.34
N.82.06.IK	12-0524	Picco ØD 6.0	3.39
N.83.05.IK	12-0525	Picco ØD 5.0	3.43
R.84	12-0074	TN.. 16 04..	3.109
L.85 / R.85	12-0075 / 12-0073	TC.. 11 03..	3.107
L.86 / R.86	12-0522 / 12-0521	Applitec L730/R740	3.137
N.91.04.IK	12-0526	Picco ØD 4.0	3.41
N.92.07.IK	12-0527	Picco ØD 7.0	3.42
N.93.IK	12-0528	Doppelhalter	3.49

INHALTSVERZEICHNIS NACH BEZEICHNUNG
SUMMARY AFTER DESCRIPTION

Rückseitenwerkzeug / Back working tool	Art.Nr. / Art.no.	Halter für / holder for	Seite/ Page
L.94 / R.94	12-1151 / 12-0532	VP.. 11 03..	3.91
L.96 / R.96	12-0092 / 12-0082	VC.. 11 03..	3.73
L.97 / R.97	12-1070 / 12-0083	VC.. 13 03..	3.89
L.99 / R.99	12-1048 / 12-0547	Horn 312	3.125
N.105	12-1144	Zange ER11	3.18
N.105.IK	12-1051	Zange ER11	3.19
L.123 / R.123	12-1147 / 12-1146	16EL / 16ER	3.113
L.123.IK / R.123.IK	12-1326 / 12-1325	16EL / 16ER	3.114
L.136 / R.136	12-1159 / 12-1074	VC.. 13 03..	3.82
L.137 / R.137	12-1161 / 12-1160	DC.. 11 T3..	3.60
L.138 / R.138	12-1163 / 12-1162	CC.. 06 02..	3.95
L.139 / R.139	12-1165 / 12-1164	VC.. 11 03..	3.74
L.190 / R.190	12-1285 / 12-1284	CN.. 12 04..	3.103
L.199 / R.199	12-1317 / 12-1316	Horn S274	3.116
L.199.IK / R.199.IK	12-1390 / 12-1389	Horn S274	3.118
L.217 / R.217	12-1357 / 12-1356	YW.. 11 T2..	3.66
L.231 / R.231	12-1403 / 12-1402	Horn 312	3.126
L.615 / R.615	12-1132 / 12-1131	Precitool 615	3.138

Grundhalter G
Basic holder G

STAR-
Maschinen

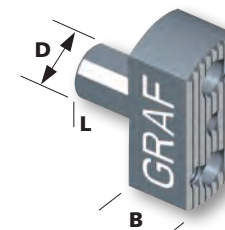

D	L	B	Bezeichnung Description	Bestell-Nummer Order-Number
16	21	20	G.016.021.SR10	12-1082
Lochbild/hole pattern			X=0	Y=32

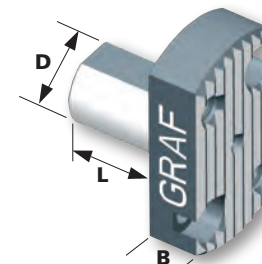

D	L	B	Bezeichnung Description	Bestell-Nummer Order-Number
16	21	12	G.016.021. SR16.20R	12-0011
Lochbild/hole pattern			X=16	Y=26

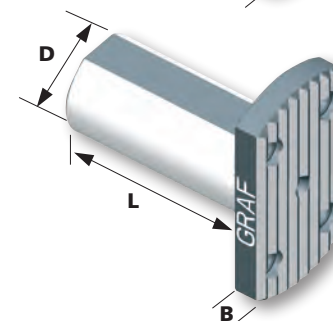

D	L	B	Bezeichnung Description	Bestell-Nummer Order-Number
16	21	6	G.016.021	12-0006
22	30	6	G.022.030	12-0010
22	70	6	G.022.070	12-0007
22	23	6	G.022.023	12-0008

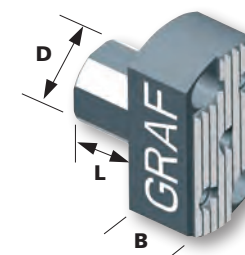

D	L	B	Bezeichnung Description	Bestell-Nummer Order-Number
22	20	20	G.022.020.S3	12-1083
Lochbild/hole pattern			X=14	Y=38

Lochbild X und Y Bemaßung symmetrisch zur Mittelachse · Hole pattern X and Y dimension symmetrically to the central axis

**STAR-
Maschinen**

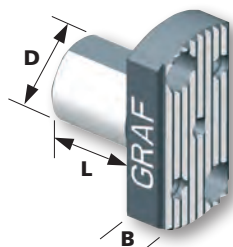

D	L	B	Bezeichnung Description	Bestell-Nummer Order-Number
22	25	12	G.022.025.S3 (SR16/20R)	12-0005
Lochbild/hole pattern			X=14	Y=38

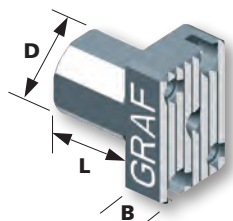

D	L	B	Bezeichnung Description	Bestell-Nummer Order-Number
22	24	12	G.022.024.S1 (SR20 R IV/SW20)	12-1094
Lochbild/hole pattern			X=12	Y=30

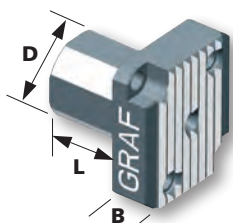

D	L	B	Bezeichnung Description	Bestell-Nummer Order-Number
22	24	12	G.022.024.S2 (SR20 R IV/SW20)	12-1095
Lochbild/hole pattern			X=25	Y=30

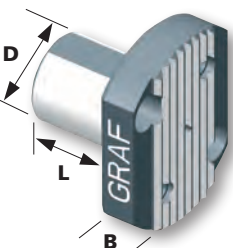

D	L	B	Bezeichnung Description	Bestell-Nummer Order-Number
22	25	12	G.022.025.SR32	12-0009
Lochbild/hole pattern			X=27,5	Y=26

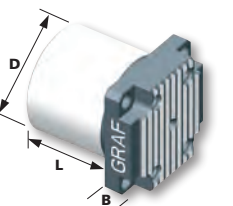

D	L	B	Bezeichnung Description	Bestell-Nummer Order-Number
34	30	12	G.034.030.S4 (ECAS 32)	12-1035
Lochbild/hole pattern			X=29,7	Y=29,7

Lochbild X und Y Bemaßung symmetrisch zur Mittelachse · Hole pattern X and Y dimension symmetrically to the central axis

**Grundhalter G
Basic holder G**

**CITIZEN-
Maschinen**

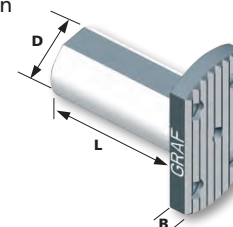

D	L	B	Bezeichnung Description	Bestell-Nummer Order-Number
3/4"	40	6	G.034.040	12-0540
3/4"	50	6	G.034.050	12-0541
3/4"	120	6	G.034.120	12-0893
20	30	6	G.020.030	12-0539
1"	30	6	G.010.030	12-0013
1"	60	6	G.010.060	12-0542
1"	100	6	G.010.100	12-1018

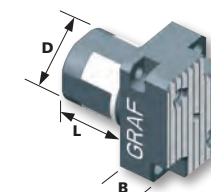

D	L	B	Bezeichnung Description	Bestell-Nummer Order-Number
25	25	19	G.025.025.C2	12-1042
Lochbild/hole pattern			X=19	Y=33

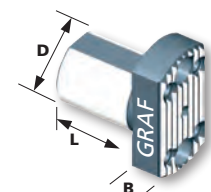

D	L	B	Bezeichnung Description	Bestell-Nummer Order-Number
24	25	12	G.024.025.K16	12-1320
Lochbild/hole pattern			X=0	Y=32,5

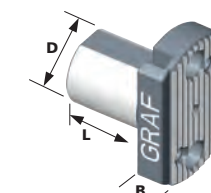

D	L	B	Bezeichnung Description	Bestell-Nummer Order-Number
25	30	12	G.025.030.C1	12-0554
Lochbild/hole pattern			X=0	Y=36

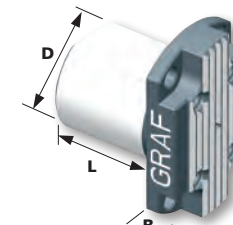

D	L	B	Bezeichnung Description	Bestell-Nummer Order-Number
31	32	12	G.031.032.C4	12-1049
Lochbild/hole pattern			X=23,5	Y=40,7

Lochbild X und Y Bemaßung symmetrisch zur Mittelachse · Hole pattern X and Y dimension symmetrically to the central axis

MAIER-
Maschinen

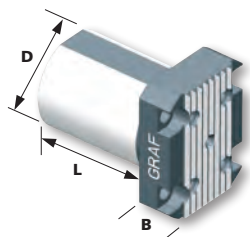

D	L	B	Bezeichnung Description	Bestell-Nummer Order-Number
34	20	15	G.034.020	12-1029
Lochbild/hole pattern			X=29,7	Y=29,7
34	44	12	G.034.044	12-0805
Lochbild/hole pattern			X=29,7	Y=29,7

TRAUB-
Maschinen

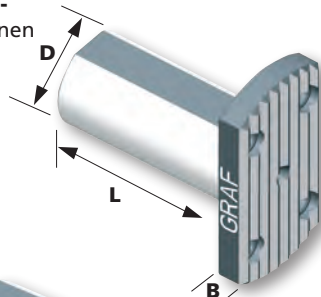

D	L	B	Bezeichnung Description	Bestell-Nummer Order-Number
16	40	6	G.016.040	12-0095
16	100	6	G.016.100	12-0087

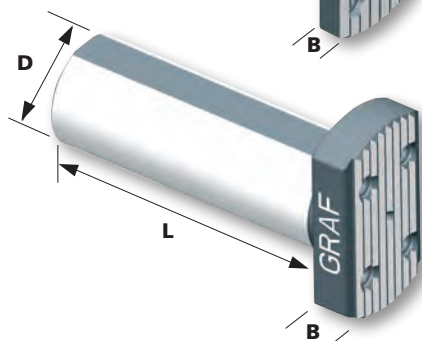

D	L	B	Bezeichnung Description	Bestell-Nummer Order-Number
28	80	12	G.028.080	12-0014

HANWHA-
Maschinen

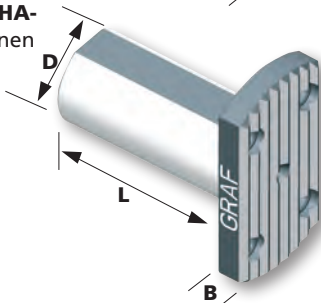

D	L	B	Bezeichnung Description	Bestell-Nummer Order-Number
20	40	6	G.020.040	12-0056

Lochbild X und Y Bemaßung symmetrisch zur Mittelachse · Hole pattern X and Y dimension symmertrically to the central axis

Grundhalter G
Basic holder G

HANWHA-
Maschinen

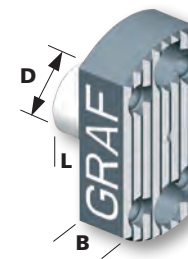

D	L	B	Bezeichnung Description	Bestell-Nummer Order-Number
15	12	12,5	G.015.012.H1	12-0081
Lochbild/hole pattern			X=0	Y=32

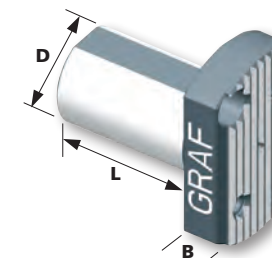

D	L	B	Bezeichnung Description	Bestell-Nummer Order-Number
25	40	12	G.025.040	12-0036
Lochbild/hole pattern			X=20,5	Y=35,5
25	60	12	G.025.060	12-0807
Lochbild/hole pattern			X=19	Y=33
28	6	12	G.028.006	12-0054
Lochbild/hole pattern			X=20,5	Y=35,5
32	25	12	G.032.025.H5	12-0808
Lochbild/hole pattern			X=28,3	Y=28,3
32	40	12	G.032.040.H5	12-1044
Lochbild/hole pattern			X=28,3	Y=28,3
33	35	12	G.033.035.H3	12-0806
Lochbild/hole pattern			X=23	Y=33

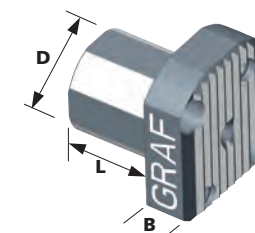

D	L	B	Bezeichnung Description	Bestell-Nummer Order-Number
25	25	12	G.025.025.H6	12-1186
Lochbild/hole pattern			X=25,5	Y=25,5

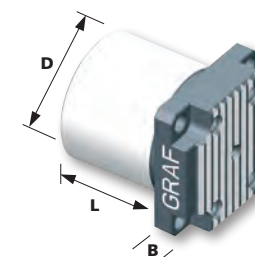

D	L	B	Bezeichnung Description	Bestell-Nummer Order-Number
35	40	13	G.035.040	12-0815
Lochbild/hole pattern			X=30	Y=30
36	37	13	G.036.037	12-0814
Lochbild/hole pattern			X=32	Y=32

Lochbild X und Y Bemaßung symmetrisch zur Mittelachse · Hole pattern X and Y dimension symmertrically to the central axis

HANWHA-
Maschinen

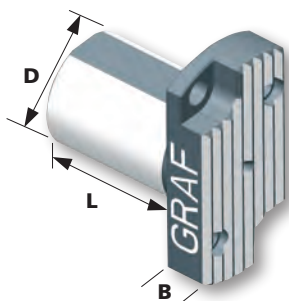

D	L	B	Bezeichnung Description	Bestell-Nummer Order-Number
23	30	10	G.023.030.H2	12-0091
Lochbild/hole pattern			X=13,7	Y=37,6

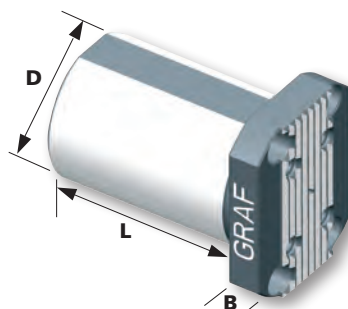

D	L	B	Bezeichnung Description	Bestell-Nummer Order-Number
42	60	12	G.042.060	12-0810
Lochbild/hole pattern			X=25,5	Y=44,1

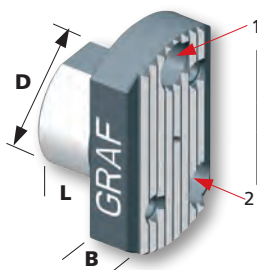

D	L	B	Bezeichnung Description	Bestell-Nummer Order-Number
28	15	12	G.028.015	12-0076
Lochbild/hole pattern			X ₁ =0 X ₂ =10,5	Y ₁ =19,5 Y ₂ =16,5

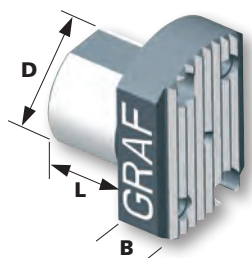

D	L	B	Bezeichnung Description	Bestell-Nummer Order-Number
25	20	12	G.025.020.H4	12-1072
Lochbild/hole pattern			X=13,7	Y=32,2

Lochbild X und Y Bemaßung symmetrisch zur Mittelachse · Hole pattern X and Y dimension symmertrically to the central axis

Grundhalter G
Basic holder G

NEXTURN-
Maschinen

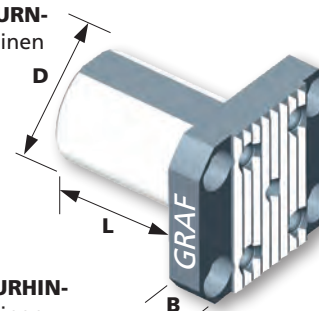

D	L	B	Bezeichnung Description	Bestell-Nummer Order-Number
25	35	10	G.025.035	12-1355
Lochbild/hole pattern			X=30,2	Y=30,2
25	38	10	G.025.038	12-1371
Lochbild/hole pattern			X=33	Y=27

MANURHIN-
Maschinen

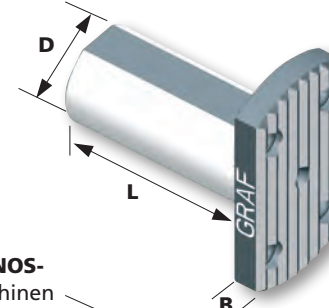

D	L	B	Bezeichnung Description	Bestell-Nummer Order-Number
16	40	6	G.016.040	12-0095
20	150	6	G.020.150	12-0531
25	30	6	G.025.030	12-0159
25	70	6	G.025.070	12-0019
25	100	6	G.025.100	12-0020
25	160	6	G.025.160	12-0799

TORNOS-
Maschinen

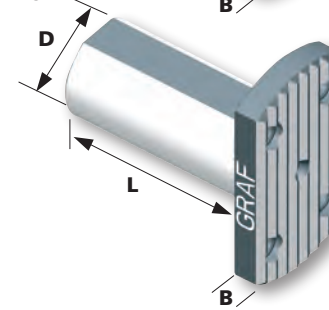

D	L	B	Bezeichnung Description	Bestell-Nummer Order-Number
20	100	6	G.020.100	12-0015
20	150	6	G.020.150	12-0531
25	70	6	G.025.070	12-0019
25	100	6	G.025.100	12-0020
25	160	6	G.025.160	12-0799

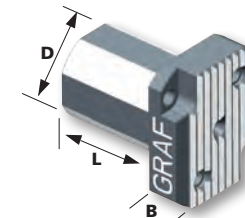

D	L	B	Bezeichnung Description	Bestell-Nummer Order-Number
28	36	12	G.028.036	12-1150
Lochbild/hole pattern			X=27	Y=27

Lochbild X und Y Bemaßung symmetrisch zur Mittelachse · Hole pattern X and Y dimension symmertrically to the central axis

TORNOS-
Maschinen

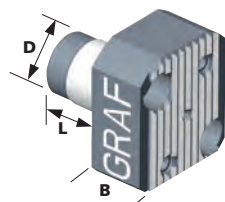

D	L	B	Bezeichnung Description	Bestell-Nummer Order-Number
20	25	20	G.020.025	12-1209
Lochbild/hole pattern			X=24	Y=25,6

TSUGAMI-
Maschinen

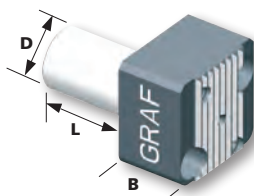

D	L	B	Bezeichnung Description	Bestell-Nummer Order-Number
20	35	25	G.020.035	12-0897
Lochbild/hole pattern			X=26	Y=18

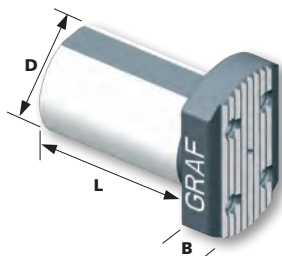

D	L	B	Bezeichnung Description	Bestell-Nummer Order-Number
32	50	12	G.032.050	12-0896

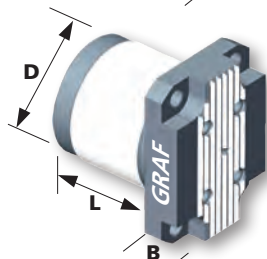

D	L	B	Bezeichnung Description	Bestell-Nummer Order-Number
42	40	15	G.042.040	12-1245
Lochbild/hole pattern			X=29	Y=49

VDI-AUFNAHMEN

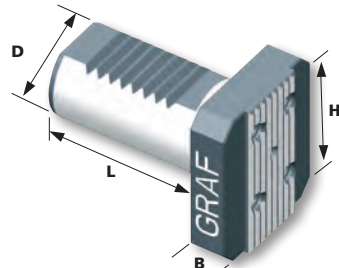

D	L	H	B	Bezeichnung Description	Bestell-Nummer Order-Number
16	32	45	12	GV.016.032	12-0113
20	40	50	10	GV.020.040	12-0088
25	48	47,5	19	GV.025.048	12-1185
30	50	52,5	14,5	GV.030.055	12-0058

Lochbild X und Y Bemaßung symmetrisch zur Mittelachse · Hole pattern X and Y dimension symmetrically to the central axis

Zwischenstücke
Plate between

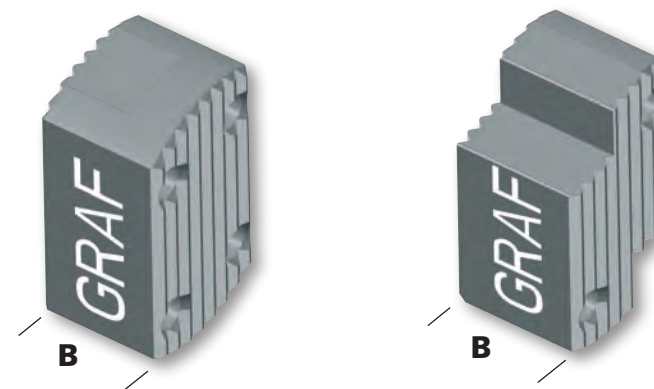

B	Bezeichnung Description	Bestell-Nummer Order-Number	B	Bezeichnung Description	Bestell-Nummer Order-Number
5	Z.5	12-0004	5	Z.5.AS	12-0533
10	Z.10	12-0001	10	Z.10.AS	12-0534
15	Z.15	12-0002	15	Z.15.AS	12-0535
20	Z.20	12-0003	20	Z.20.AS	12-0536
25	Z.25	12-0800	25	Z.25.AS	12-0537
30	Z.30	12-0801	30	Z.30.AS	12-0538

Für Grundhalter For basic holder	G.022.025.S3
	G.022.025.SR32
	G.025.060
	G.028.006
	G.032.25.H5
	G.033.035.H3
	G.025.040
	G.032.030
G.032.040.H5	
G.023.030.H2	

Höhenverstellbare Rückseitenwerkzeuge
Height adjustable back working tools

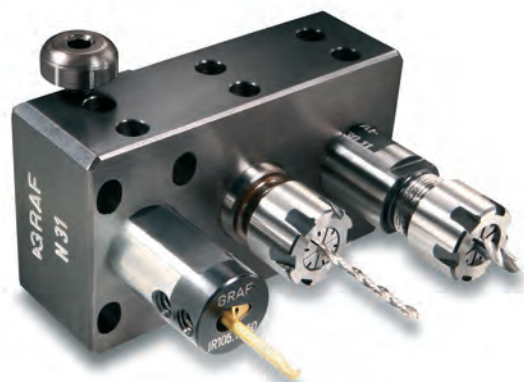

GRAF-Einsätze jetzt auch „Überkopf“ höheninstellbar.

All GRAF insert cassettes can be mounted with the insert facing up or down and you can still adjust the center height.

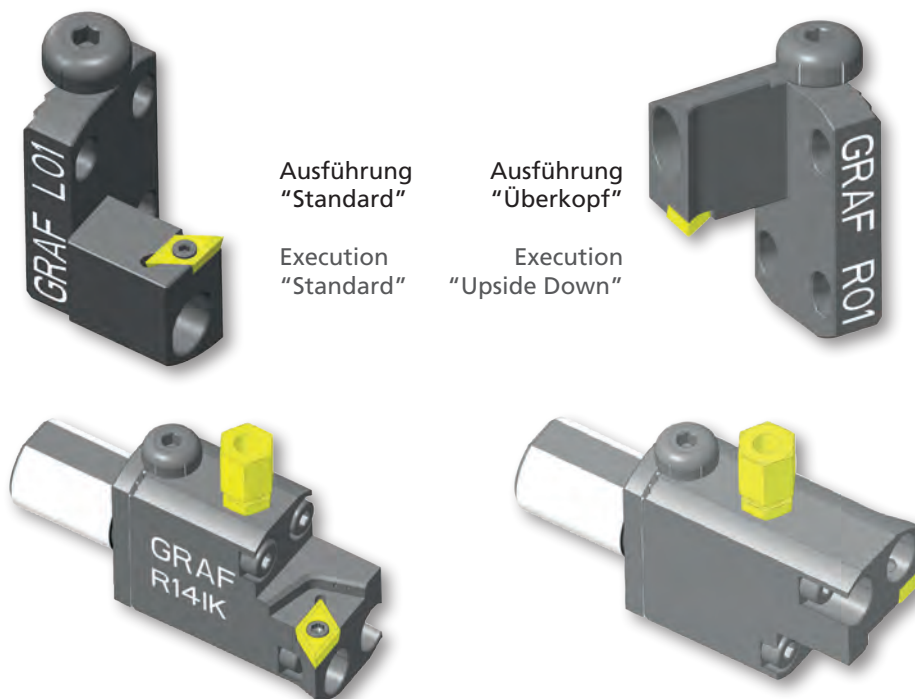

Feineinstellung kann auch „Überkopf“ vorgenommen werden.
Bessere Späneabfuhr bei grobspanigem Material, z.B. bei langspanenden
Werkstoffen wie Kunststoffe usw.

Fine adjustment is possible with the insert facing upside down for better chip
evacuation. Especially for long stringy materials such as plastic.



N.105
Bestell-Nummer/Order-Number 12-1144

Anwendungsbereich **Innenbearbeitung**
Range of application **internal processing**

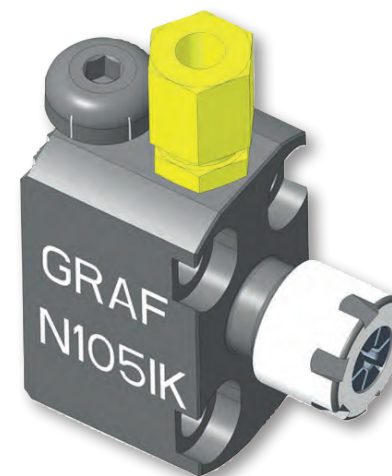
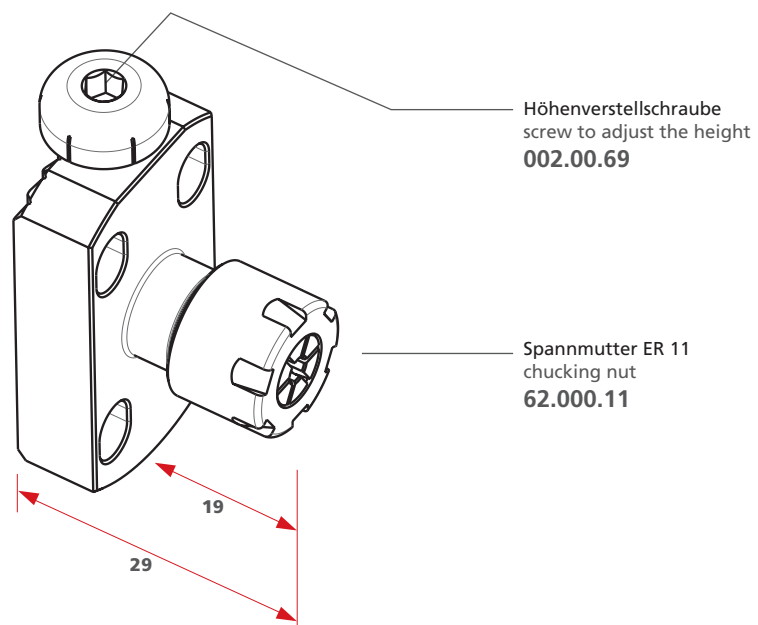

N.105.IK
Bestell-Nummer/Order-Number 12-1051

Anwendungsbereich **Innenbearbeitung**
Range of application **internal processing**

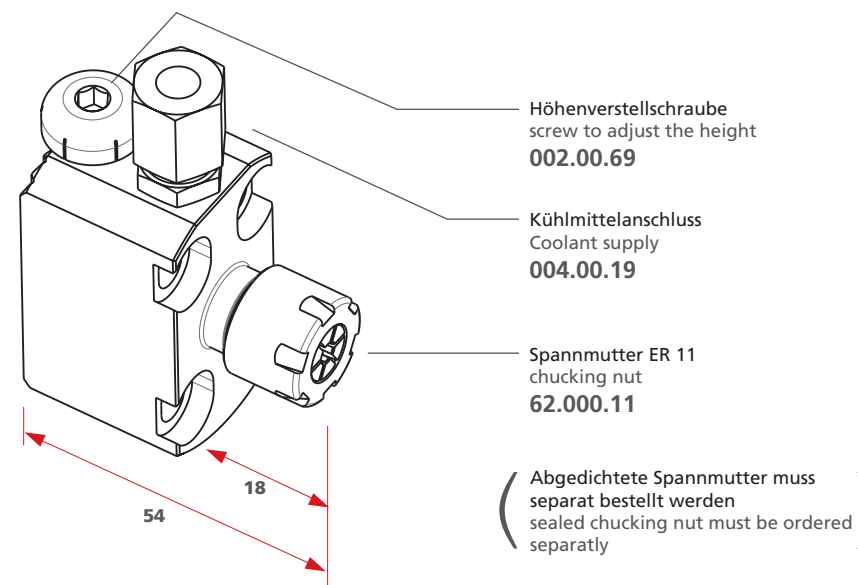

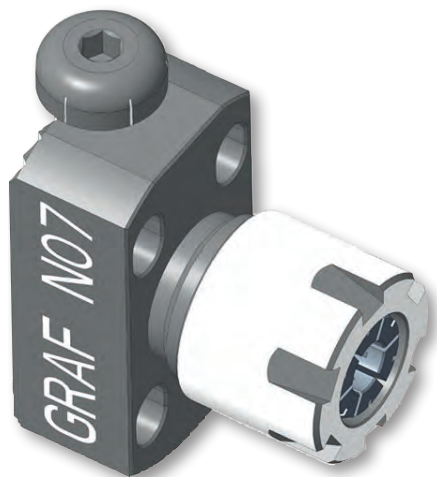

N.07
Bestell-Nummer/Order-Number 12-0033

Anwendungsbereich **Innenbearbeitung**
Range of application **internal processing**

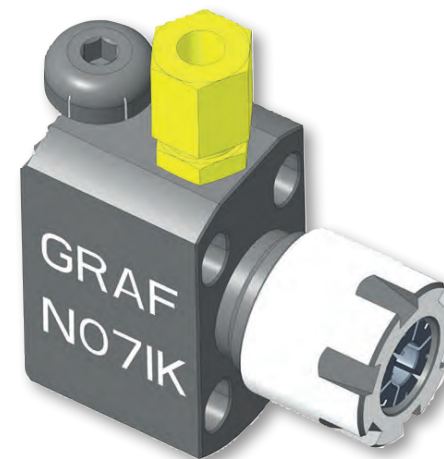
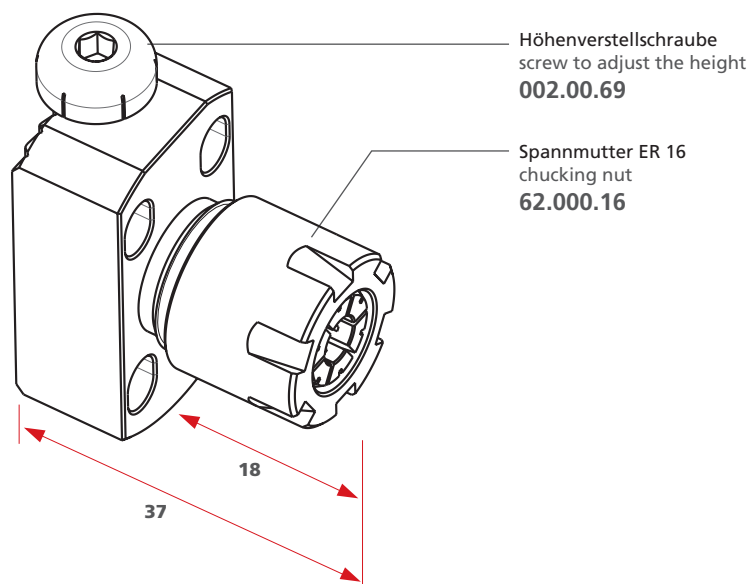

N.07.IK
Bestell-Nummer/Order-Number 12-0055

Anwendungsbereich **Innenbearbeitung**
Range of application **internal processing**

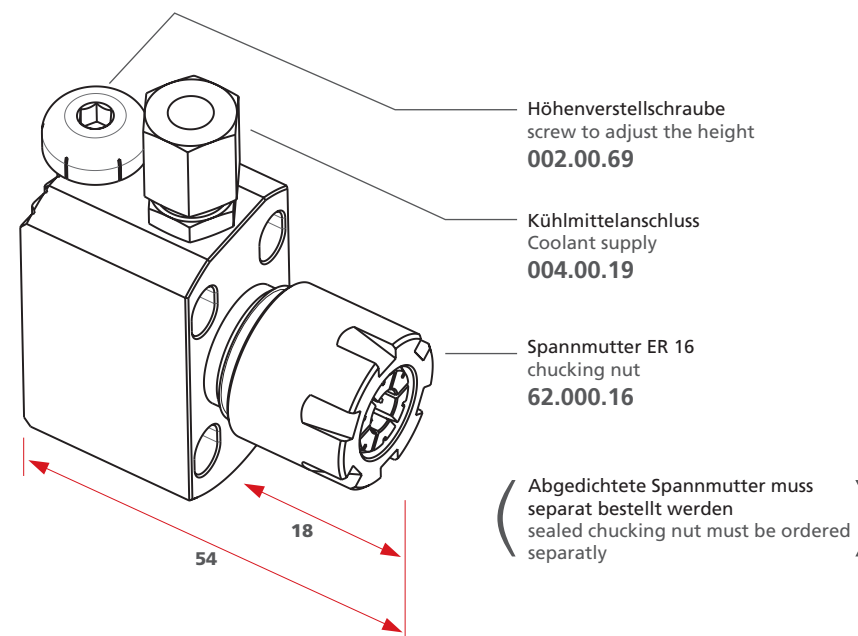

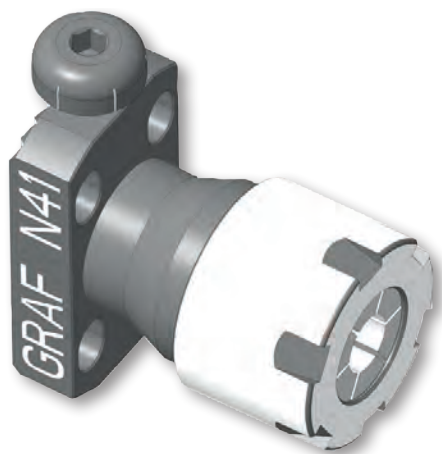

N.41
Bestell-Nummer/Order-Number 12-0450

Anwendungsbereich **Innenbearbeitung**
Range of application **internal processing**

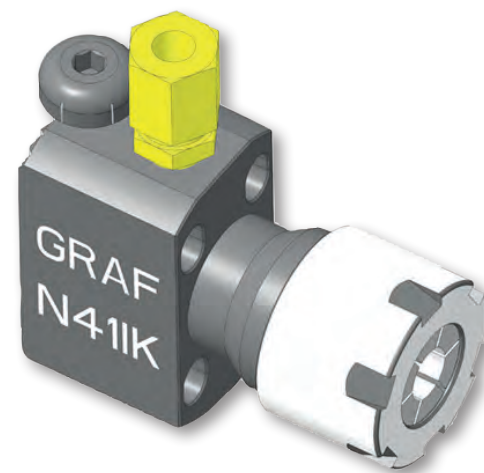
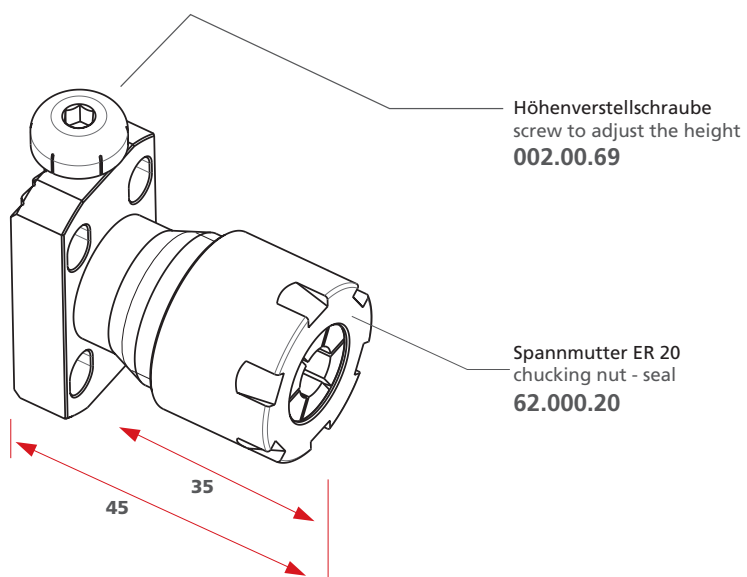

N.41.IK
Bestell-Nummer/Order-Number 12-0469

Anwendungsbereich **Innenbearbeitung**
Range of application **internal processing**

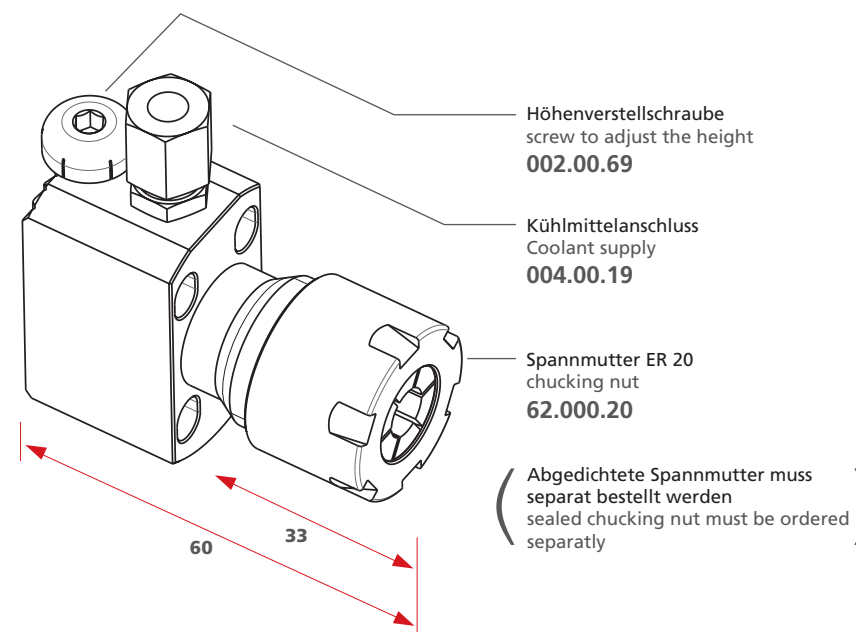



N.30

Anwendungsbereich **Innenbearbeitung**
Range of application **internal processing**

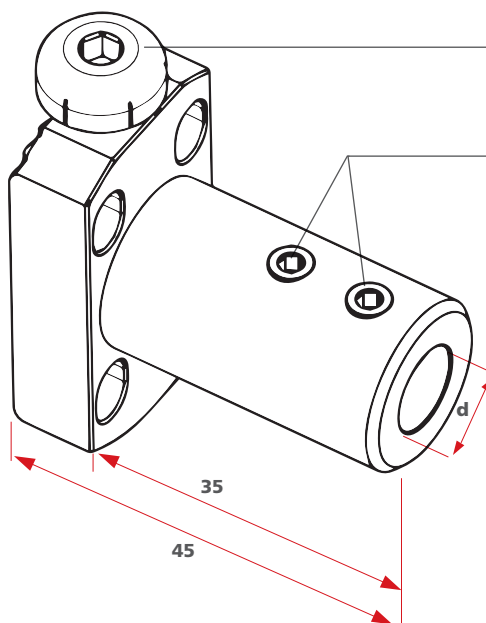

Höhenverstellungsschraube
screw to adjust the height
002.00.69

Gewindestift
set screw
002.00.21

wählbar in verschiedenen Durchmessern
selectable in different diameters
d= 4, 6, 8, 10, 12, 16

Bezeichnung Description	Ø d	Bestell-Nummer Order-Number
N.30.04	4	12-0379
N.30.06	6	12-0371
N.30.08	8	12-0372
N.30.10	10	12-0373
N.30.12	12	12-0374
N.30.16	16	12-0381

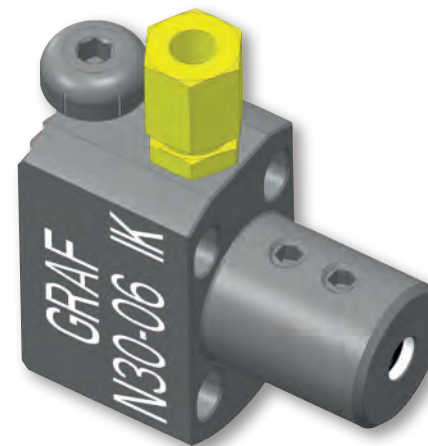

N.30.IK

Anwendungsbereich **Innenbearbeitung**
Range of application **internal processing**

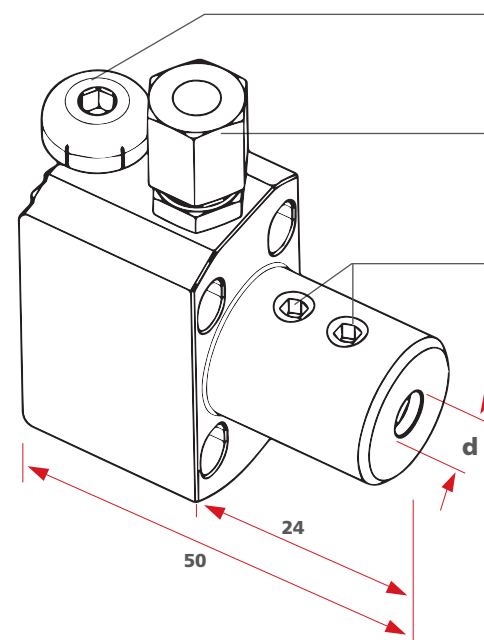

Höhenverstellungsschraube
screw to adjust the height
002.00.69

Kühlmittelanschluss
Coolant supply
004.00.19

Gewindestift
set screw
002.00.21

wählbar in verschiedenen Durchmessern
selectable in different diameters
d= 6, 8, 10, 12, 16

Bezeichnung Description	Ø d	Bestell-Nummer Order-Number
N.30.06.IK	6	12-1053
N.30.08.IK	8	12-1054
N.30.10.IK	10	12-1055
N.30.12.IK	12	12-1052
N.30.16.IK	16	12-1214

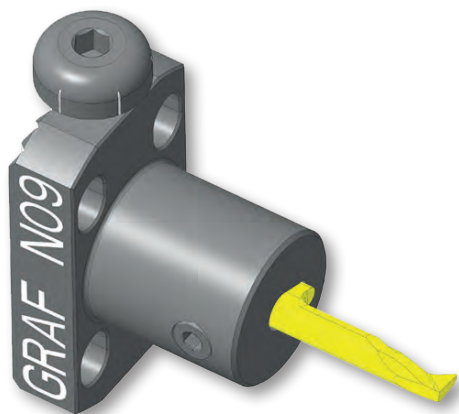

N.09
Bestell-Nummer/Order-Number 12-0155

Anwendungsbereich **Innenbearbeitung**
Range of application **internal processing**

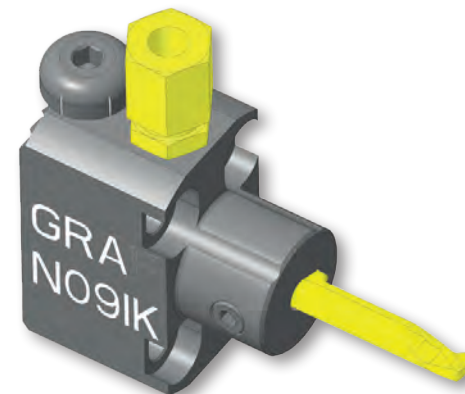
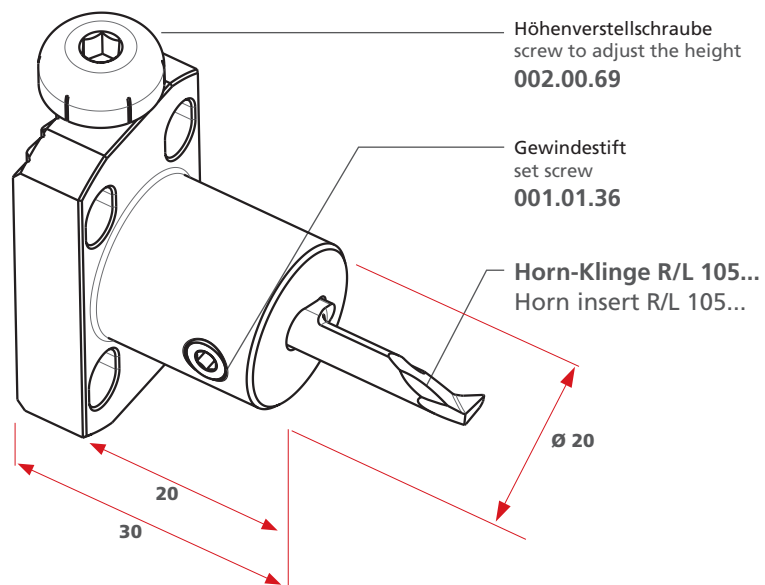

N.09.IK
Bestell-Nummer/Order-Number 12-0154

Anwendungsbereich **Innenbearbeitung**
Range of application **internal processing**

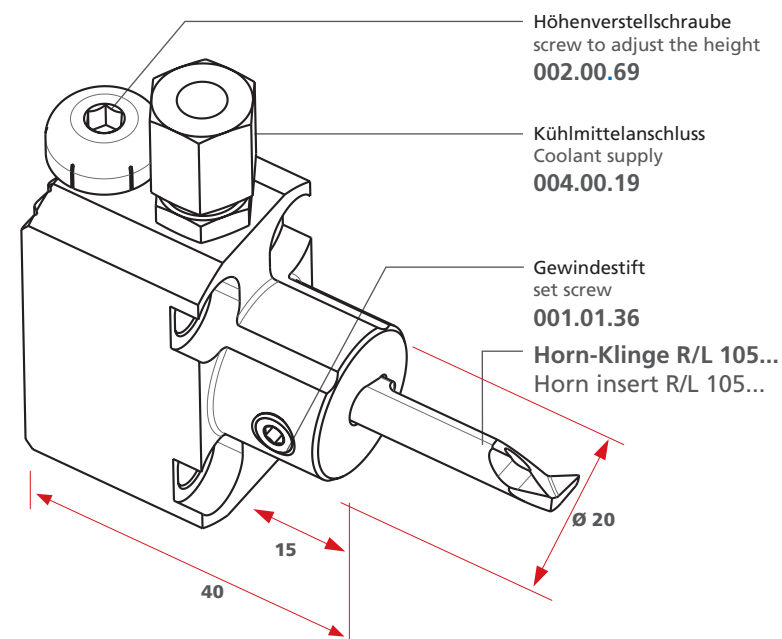



N.09.S

Anwendungsbereich **Innenbearbeitung**
Range of application **internal processing**

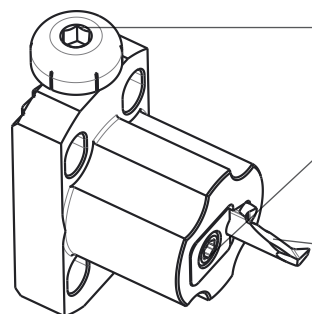

Höhenverstellungsschraube
screw to adjust the height
002.00.69

Spannelement
clamping element

Horn-Klinge R/L 105...
Horn insert R/L 105...

Größe/ size	Bestell-Nummer Order-Number
03	4.352.03
04	4.352.04
05	4.352.05

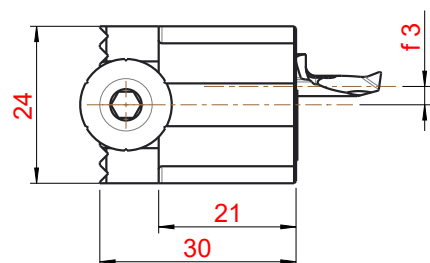

Einsatz in drei Größen
Tool holder in three sizes

Bezeichnung Description	Größe/size	Bestell-Nummer Order-Number
N.09.S.03	03	12-1358
N.09.S.04	04	12-1347
N.09.S.05	05	12-1359

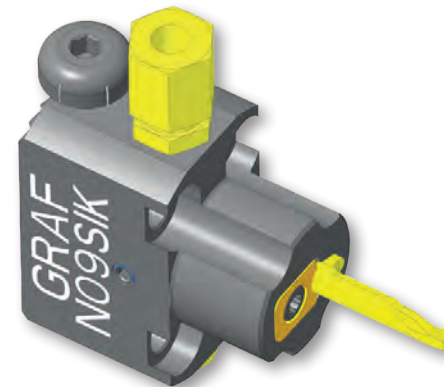

N.09.S.IK

Anwendungsbereich **Innenbearbeitung**
Range of application **internal processing**

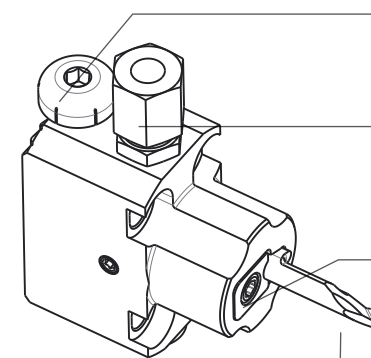

Höhenverstellungsschraube
screw to adjust the height
002.00.69

Kühlmittelanschluss
Coolant supply
004.00.19

Spannelement
clamping element

Horn-Klinge R/L 105...
Horn insert R/L 105...

Größe/ size	Bestell-Nummer Order-Number
03	4.352.03
04	4.352.04
05	4.352.05

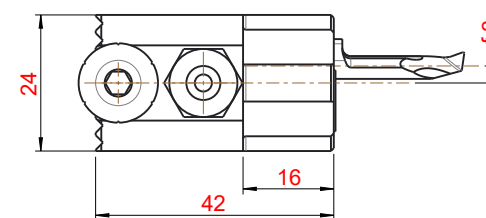

Einsatz in drei Größen
Tool holder in three sizes

Bezeichnung Description	Größe/size	Bestell-Nummer Order-Number
N.09.S.IK.03	03	12-1391
N.09.S.IK.04	04	12-1392
N.09.S.IK.05	05	12-1393

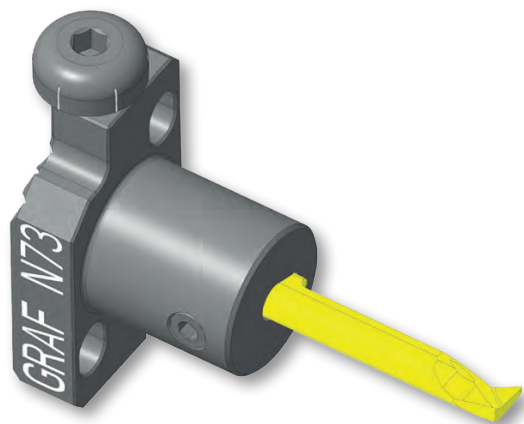

N.73
Bestell-Nummer/Order-Number 12-0156

Anwendungsbereich **Innenbearbeitung**
Range of application **internal processing**

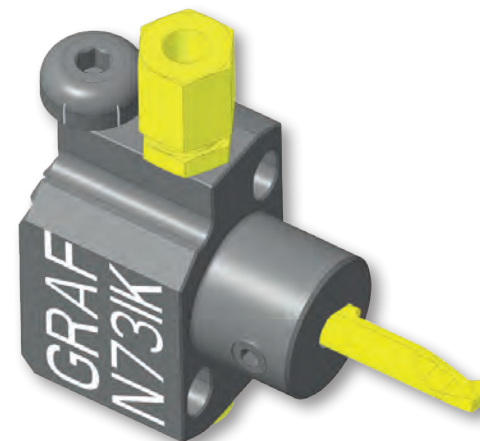
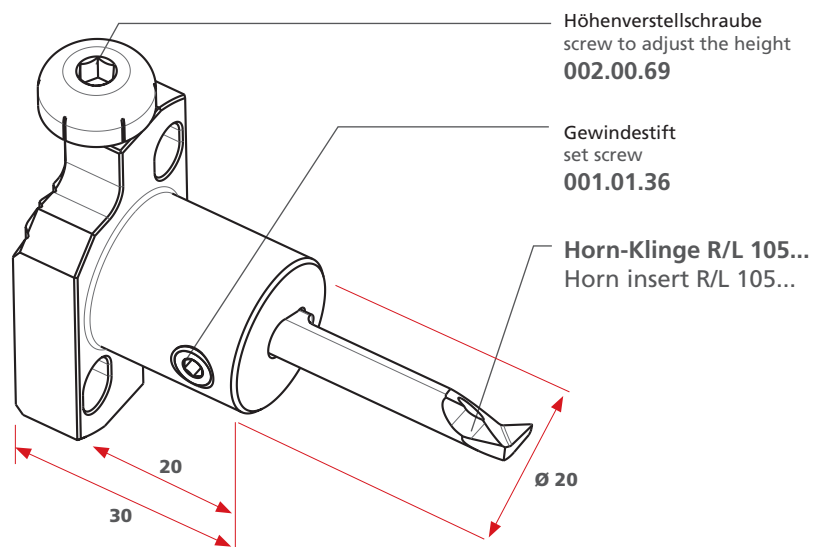

N.73.IK
Bestell-Nummer/Order-Number 12-0158

Anwendungsbereich **Innenbearbeitung**
Range of application **internal processing**

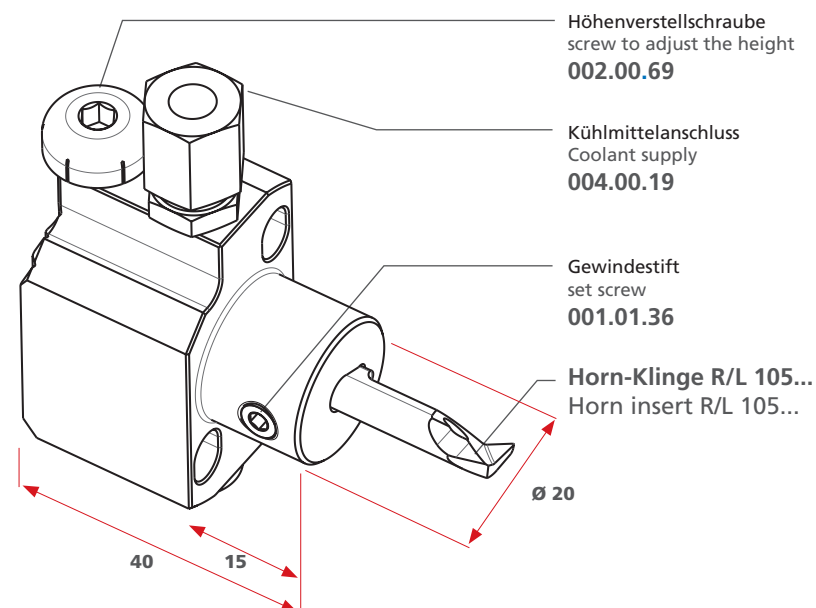

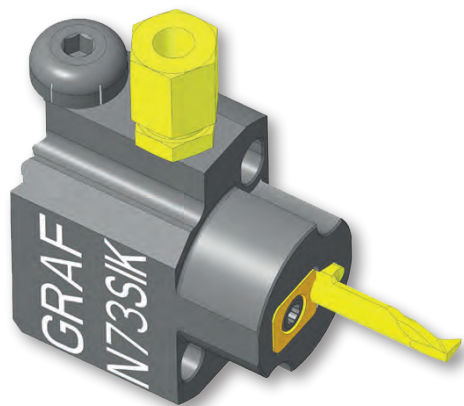

N.73.S.IK

Anwendungsbereich **Innenbearbeitung**
Range of application **internal processing**

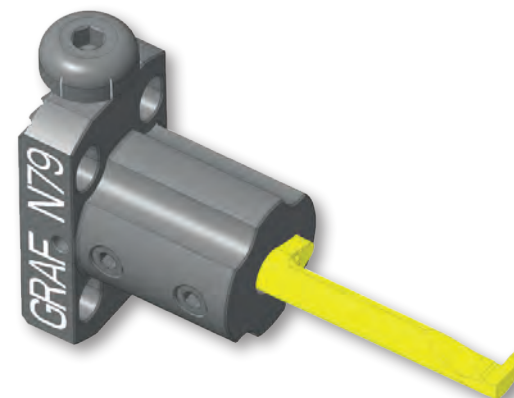
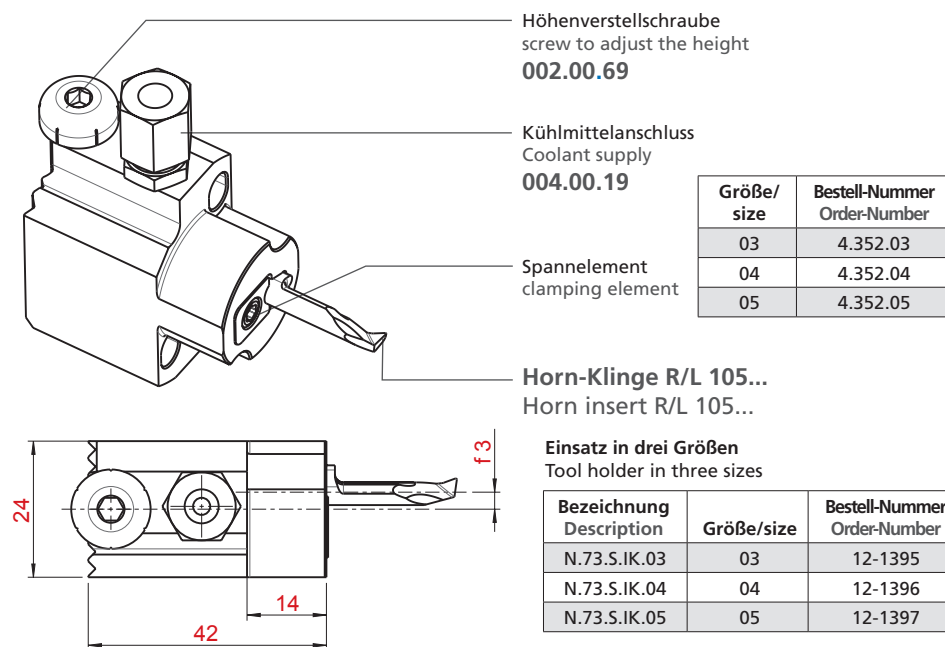

N.79

Bestell-Nummer/Order-Number 12-1071

Anwendungsbereich **Innenbearbeitung**
Range of application **internal processing**

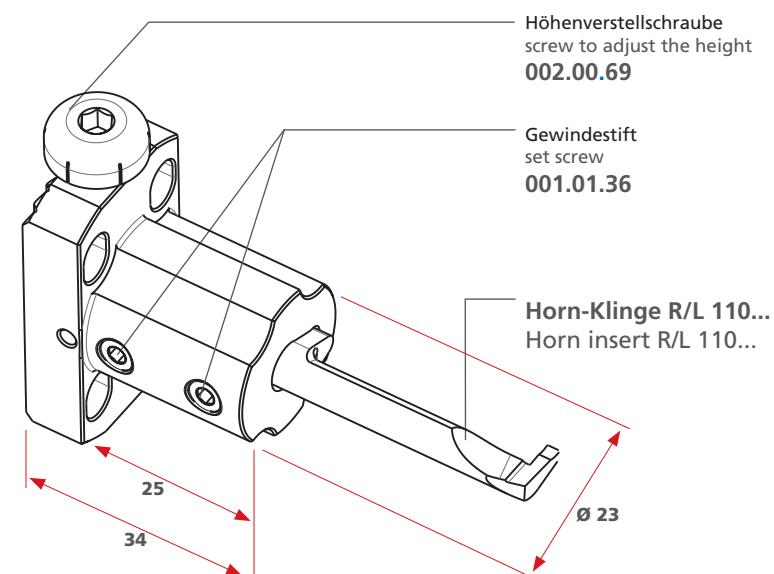

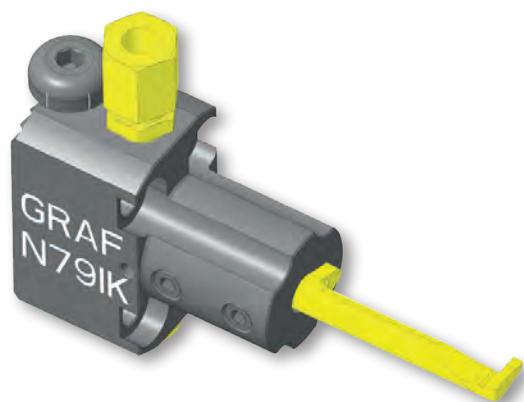

N.79.IK
Bestell-Nummer/Order-Number 12-0157

Anwendungsbereich **Innenbearbeitung**
Range of application **internal processing**

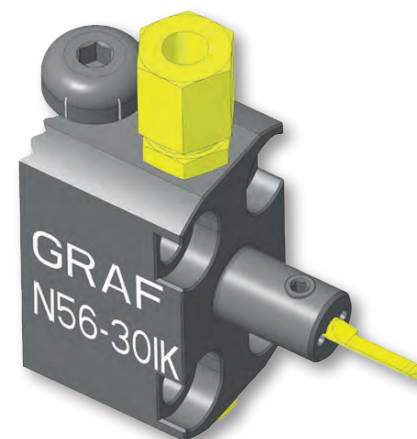
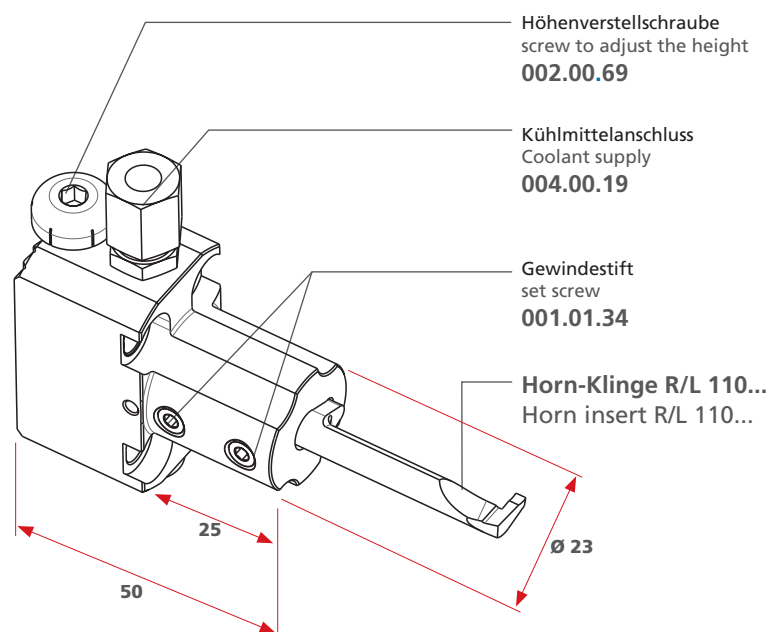

N.56.30.IK
Bestell-Nummer/Order-Number 12-0470

Anwendungsbereich **Innenbearbeitung**
Range of application **internal processing**

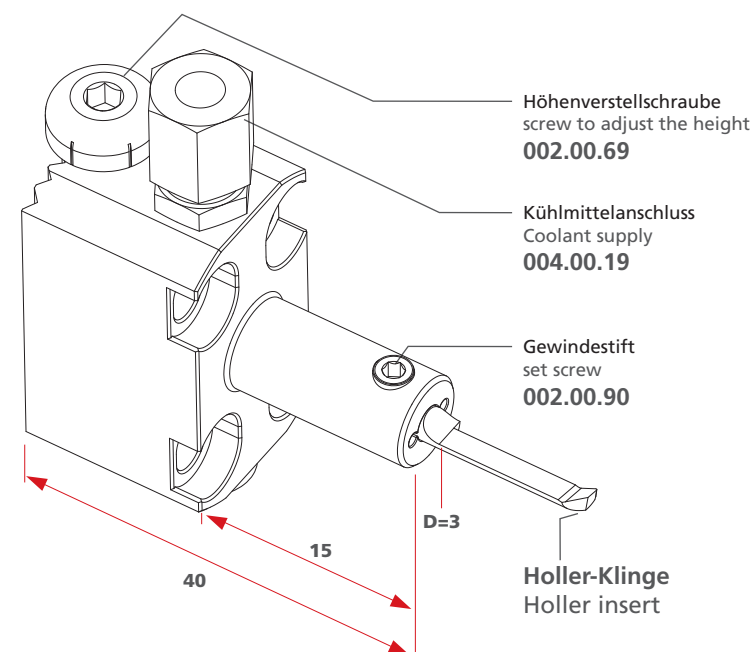

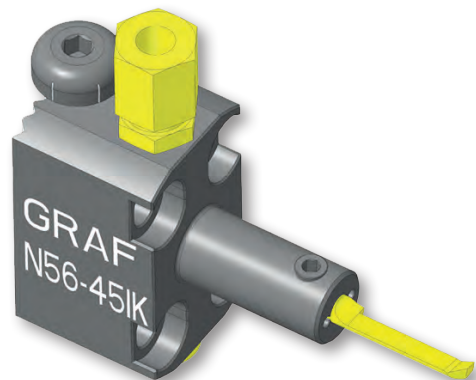

N.56.45.IK
Bestell-Nummer/Order-Number 12-0471

Anwendungsbereich **Innenbearbeitung**
Range of application **internal processing**

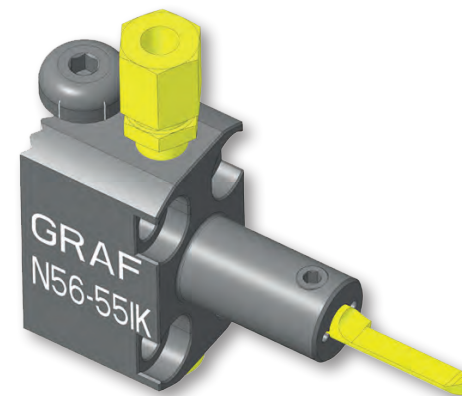
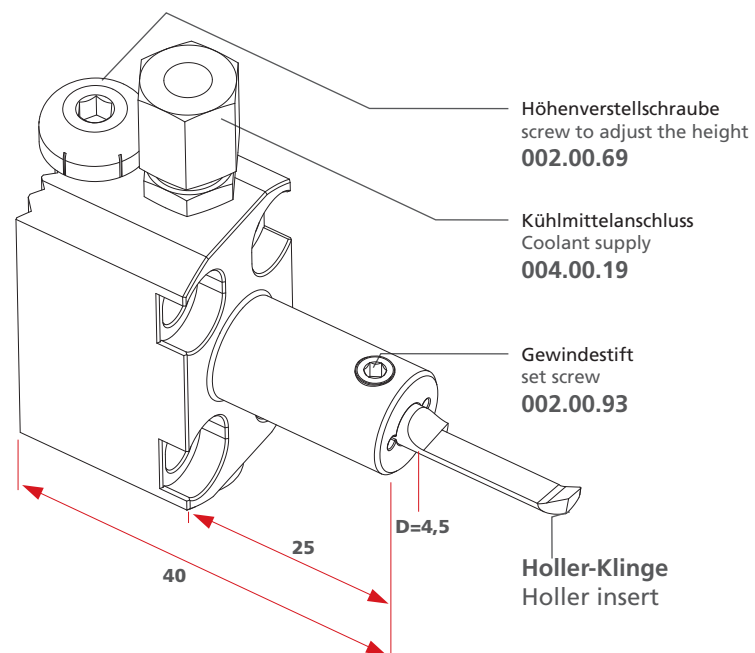

N.56.55.IK
Bestell-Nummer/Order-Number 12-0472

Anwendungsbereich **Innenbearbeitung**
Range of application **internal processing**

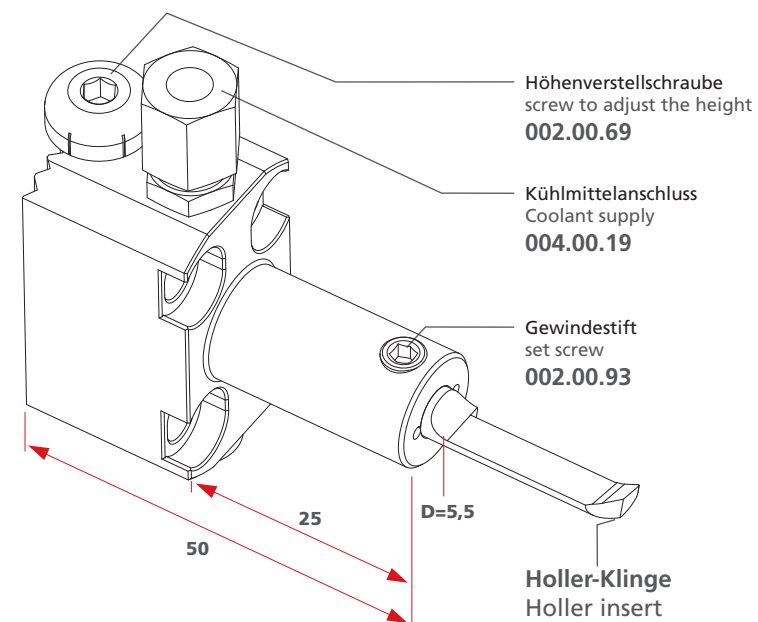

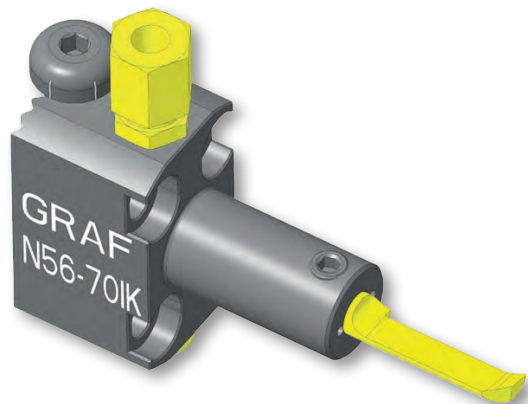

N.56.70.IK
Bestell-Nummer/Order-Number 12-0473

Anwendungsbereich **Innenbearbeitung**
Range of application **internal processing**

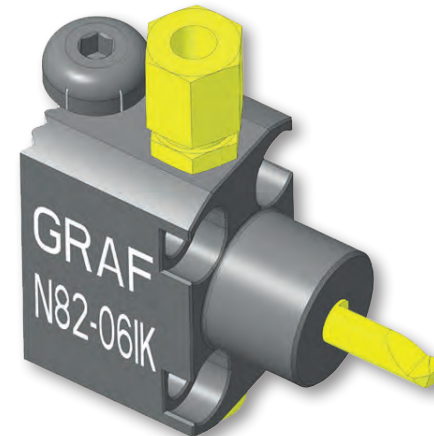
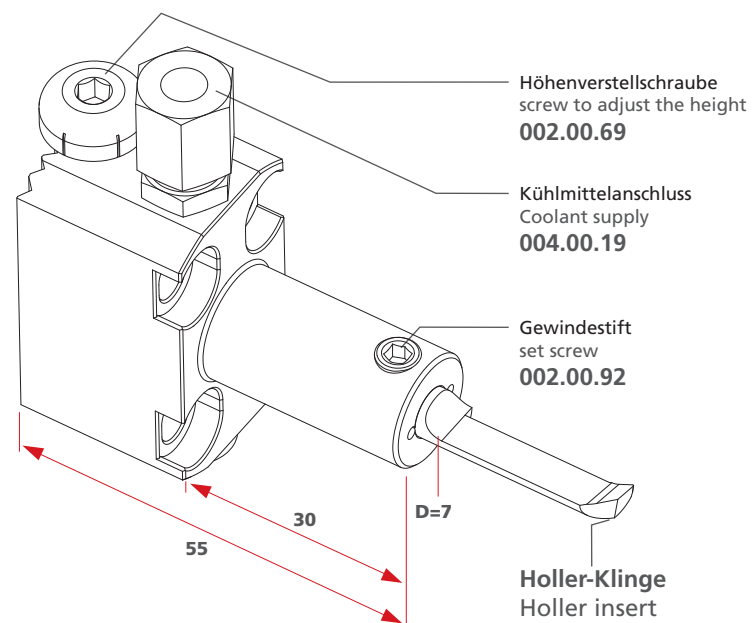

N.82.06.IK
Bestell-Nummer/Order-Number 12-0524

Anwendungsbereich **Innenbearbeitung**
Range of application **internal processing**

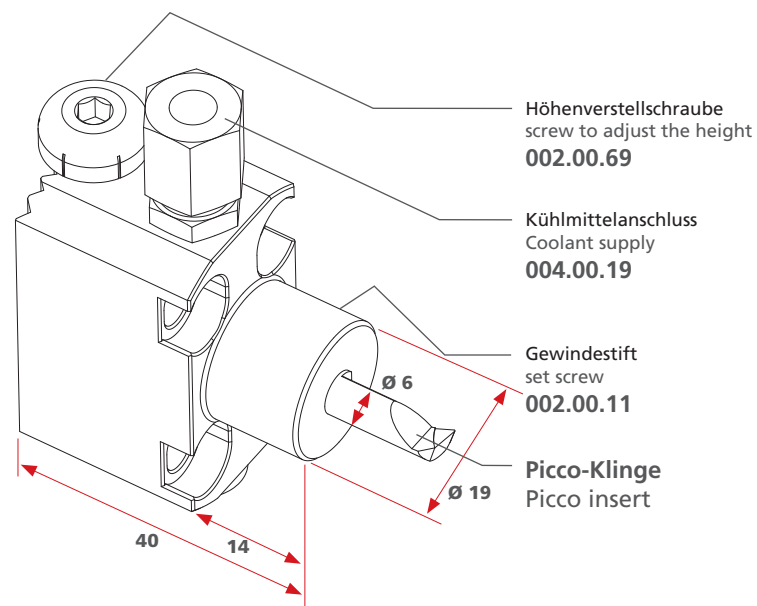

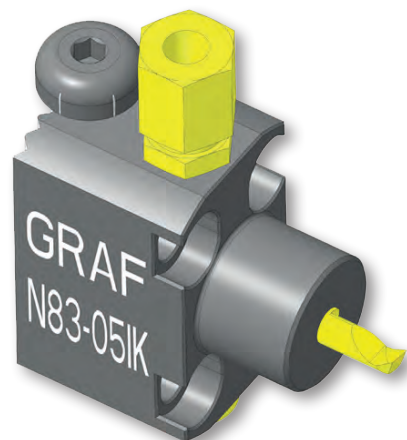

N.83.05.IK
Bestell-Nummer/Order-Number 12-0525

Anwendungsbereich **Innenbearbeitung**
Range of application **internal processing**

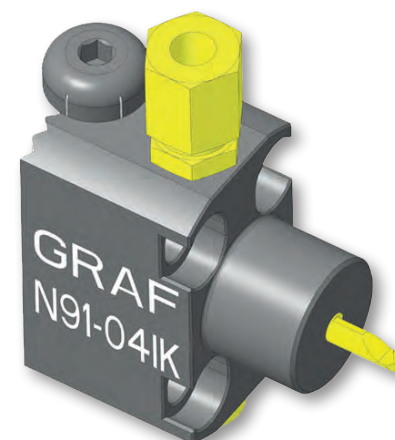
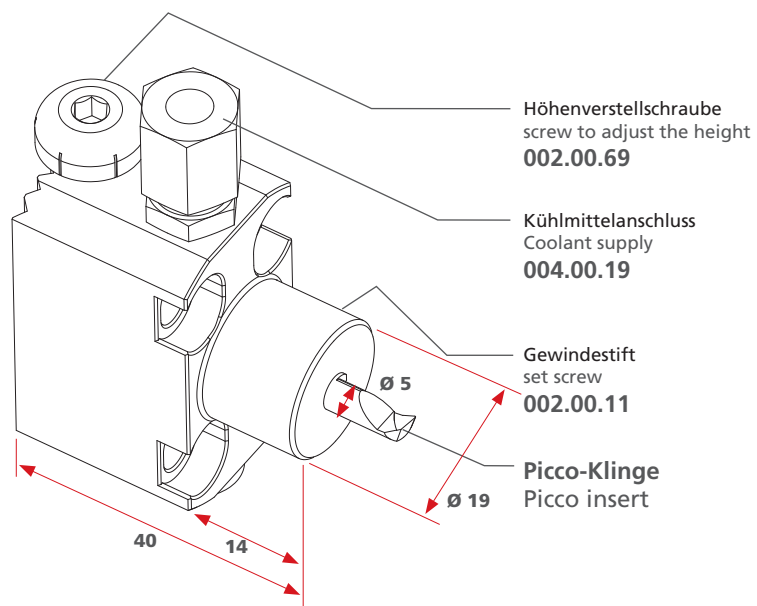

N.91.04.IK
Bestell-Nummer/Order-Number 12-0526

Anwendungsbereich **Innenbearbeitung**
Range of application **internal processing**

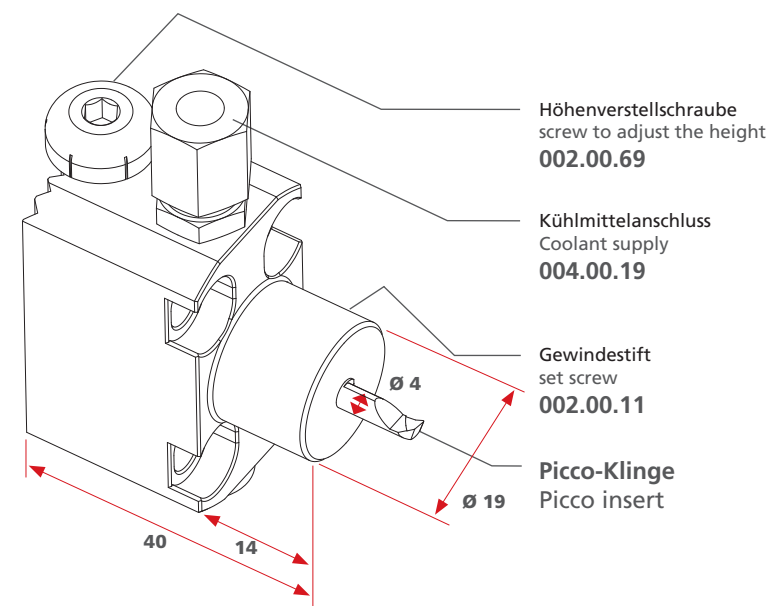

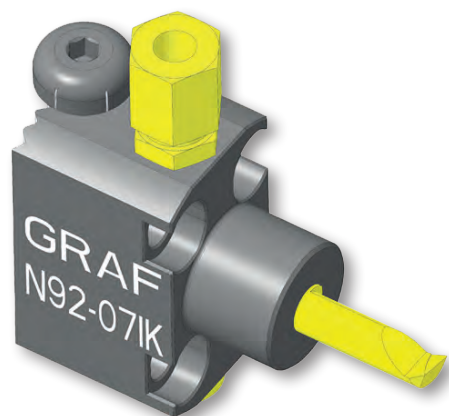

N.92.07.IK
Bestell-Nummer/Order-Number 12-0527

Anwendungsbereich **Innenbearbeitung**
Range of application **internal processing**

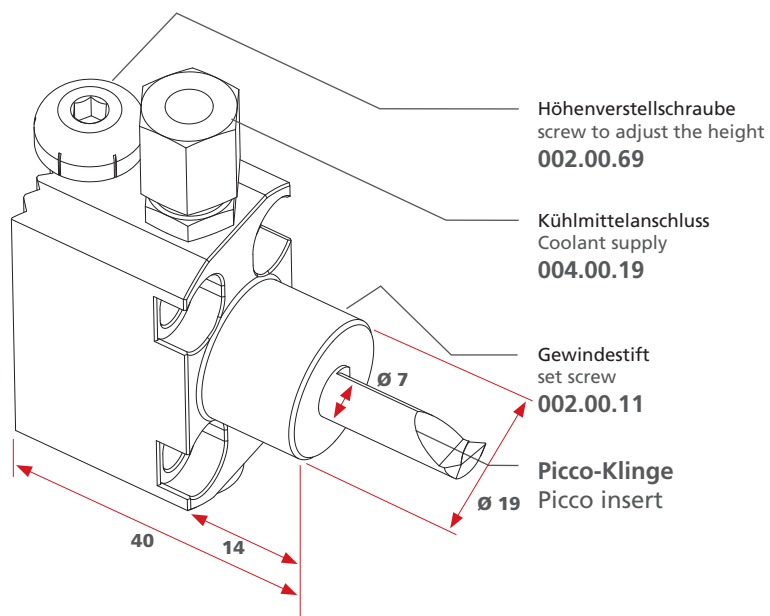

N.10
Bestell-Nummer/Order-Number 12-0037

Anwendungsbereich **Rückseitenbearbeitung**
Application **back working**

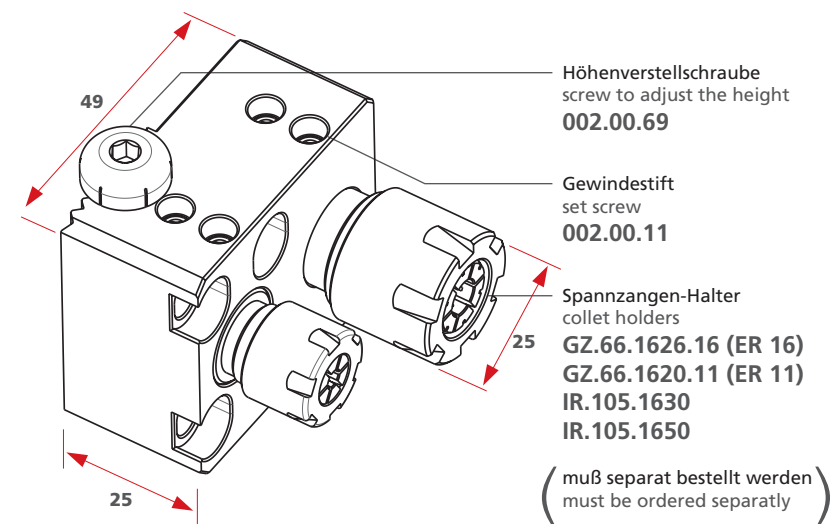

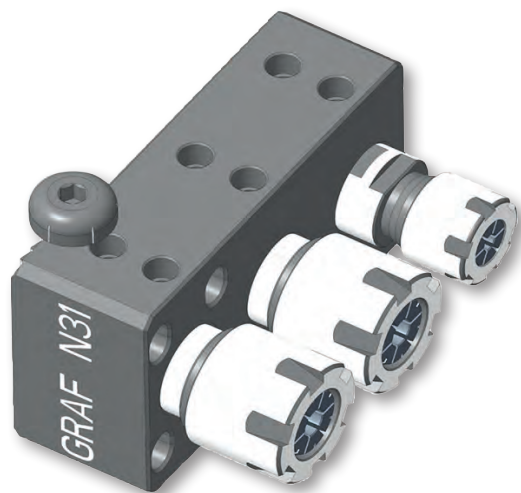

N.31
Bestell-Nummer/Order-Number 12-0798

Anwendungsbereich **Rückseitenbearbeitung**
Application **back working**

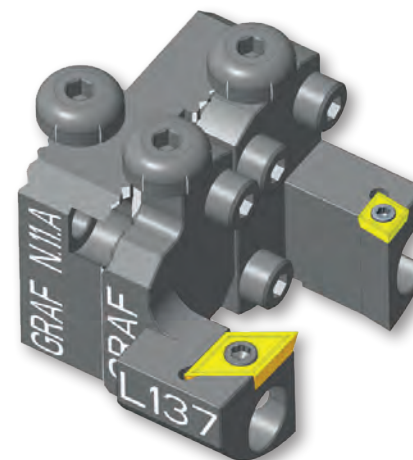
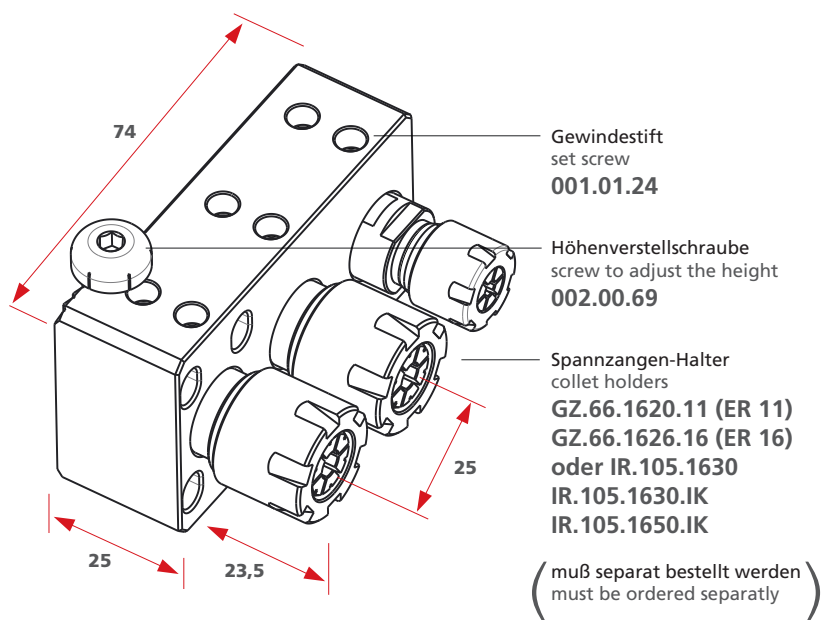

N.11.A
Bestell-Nummer/Order-Number 12-0038

Anwendungsbereich **Rückseitenbearbeitung**
Application **back working**

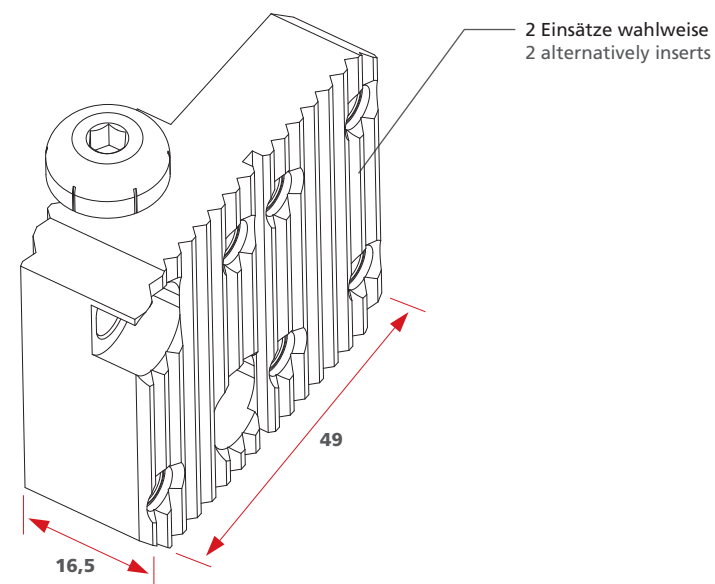

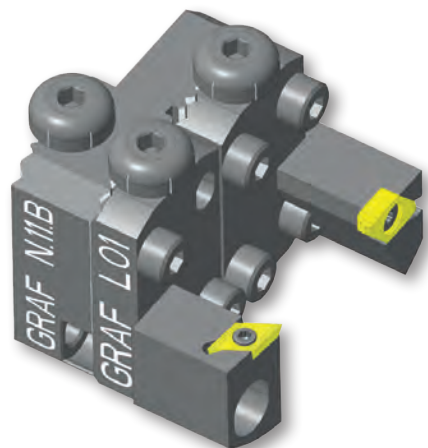

N.11.B
Bestell-Nummer/Order-Number 12-0053

Anwendungsbereich **Rückseitenbearbeitung**
Application **back working**

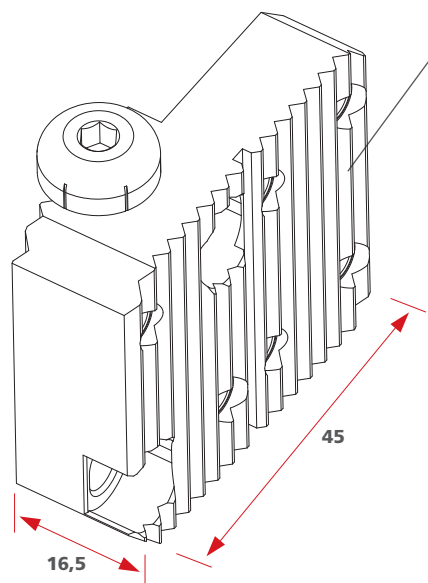

Für Grundhalter	G.022.025.S3
For basic holder	G.022.025.SR32
	G.025.060
	G.028.006
	G.032.25.H5
	G.033.035.H3
	G.016.021.SR10
	G.025.040
	G.032.040.H5
	G.032.030
	G.022.020.SR10
	G.022.024.S2
	G.023.030.H2
	G.028.015
	G.025.020

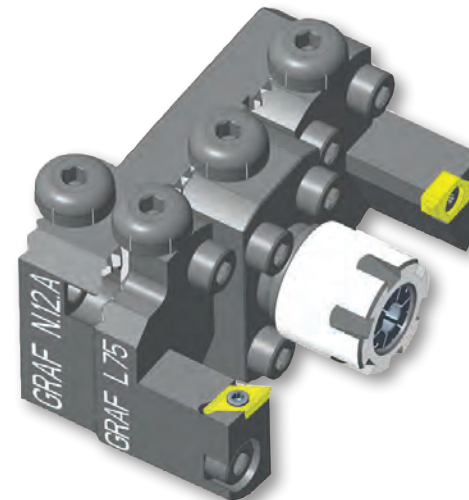

N.12.A
Bestell-Nummer/Order-Number 12-0509

Anwendungsbereich **Rückseitenbearbeitung**
Application **back working**

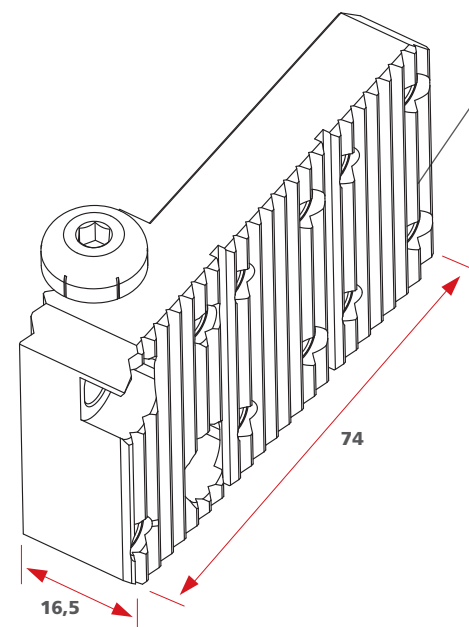

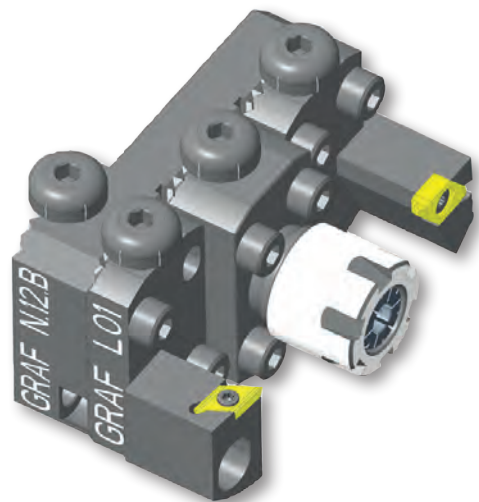

N.12.B
Bestell-Nummer/Order-Number 12-0510

Anwendungsbereich **Rückseitenbearbeitung**
Application **back working**

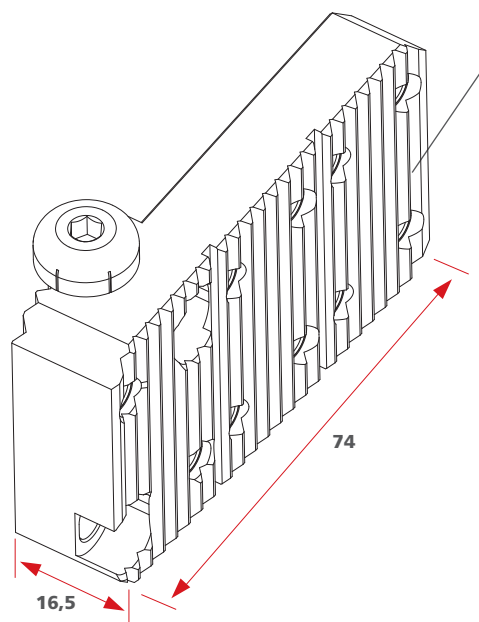

Für Grundhalter	G.022.025.S3
For basic holder	G.022.025.SR32
	G.025.060
	G.028.006
	G.032.25.H5
	G.033.35.H3
	G.016.021.SR10
	G.025.040
	G.032.040.H5
	G.032.030
	G.022.020.SR10
	G.022.024.S2
	G.023.030.H2
	G.028.015
	G.025.020

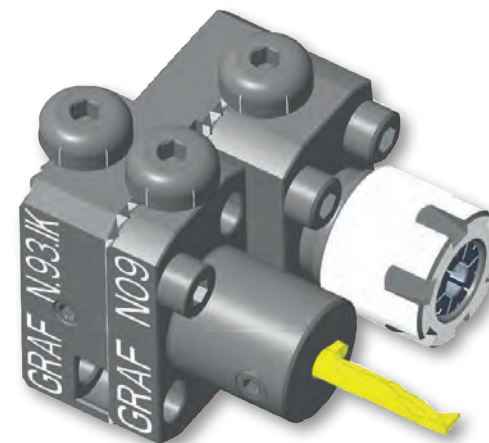

N.93.IK
Bestell-Nummer/Order-Number 12-0528

Anwendungsbereich **Rückseitenbearbeitung**
Application **back working**

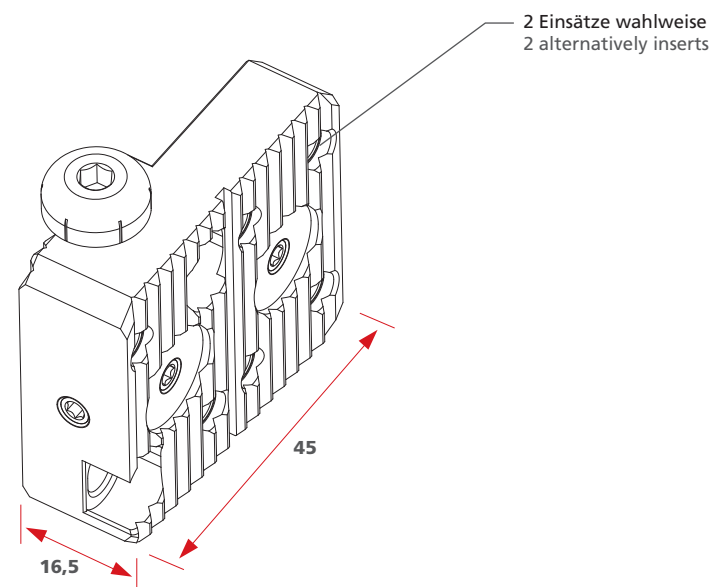

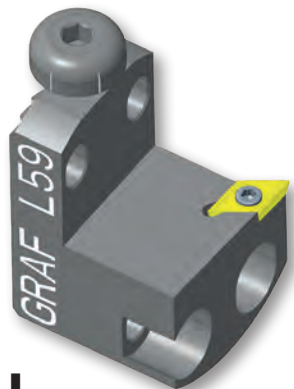

L
linksschneidend
cutting left

L.59

Bestell-Nr/Order-Number **12-0477**

Anwendungsbereich **Kopierdrehen**
Application **copy turning**

Höhenverstellungsschraube
screw to adjust the height

002.00.69

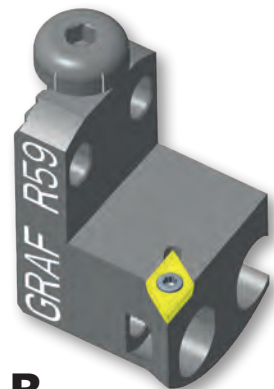

R
rechtsschneidend
cutting right

R.59

Bestell-Nr/Order-Number **12-0476**

Wendeplatte
indexable insert

DC 07.02..

Senkschraube
counter sunk-head screw

001.01.01

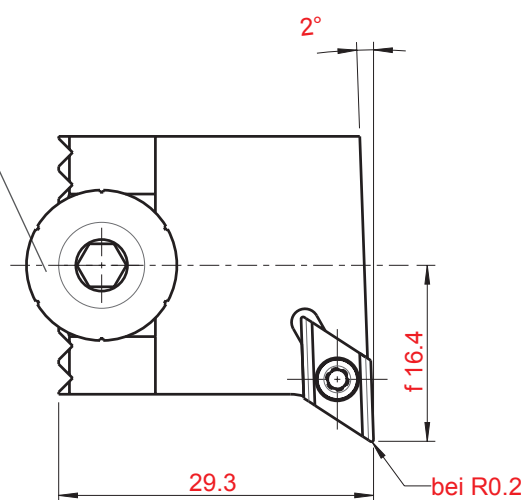

L
linksschneidend
cutting left

L.01

Bestell-Nr/Order-Number **12-0023**

Anwendungsbereich **Kopierdrehen**
Application **copy turning**

Höhenverstellungsschraube
screw to adjust the height

002.00.69

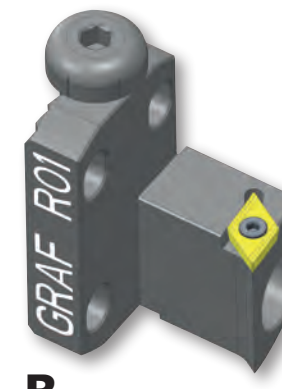

R
rechtsschneidend
cutting right

R.01

Bestell-Nr/Order-Number **12-0022**

Wendeplatte
indexable insert

DC.. 07 02..

Senkschraube
counter sunk-head screw

001.01.01

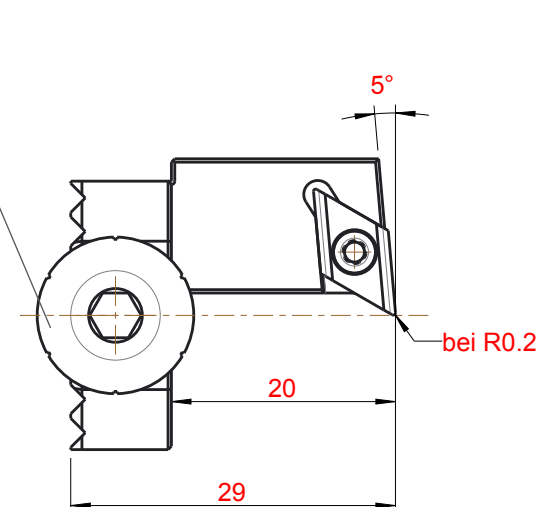



L
linksschneidend
cutting left

L.01.IK

Bestell-Nr/Order-Number **12-0161**

Anwendungsbereich **Kopierdrehen**
Application **copy turning**

Höhenverstellungsschraube
screw to adjust the height

002.00.69

Kühlmittelanschluss
Coolant supply

004.00.19

Wendeplatte
indexable insert

DC.. 07 02 ..

Senkschraube
counter sunk-head screw

001.01.01

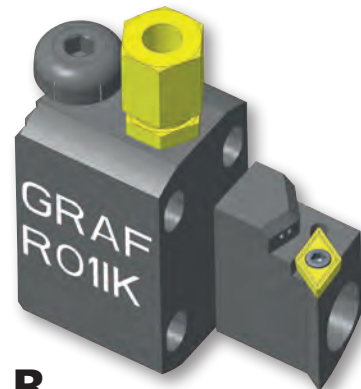
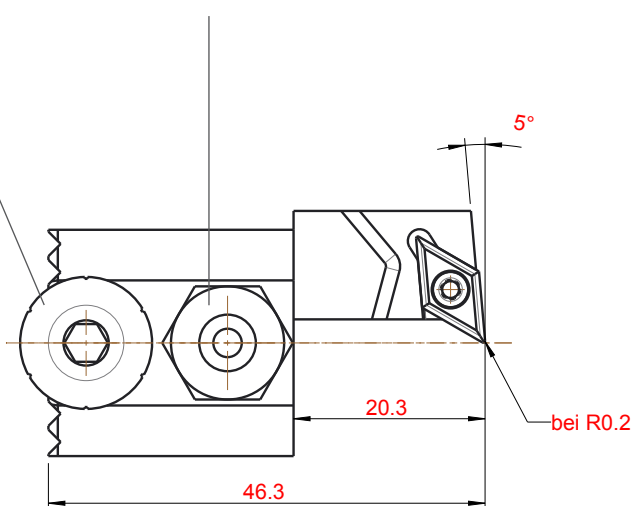

R
rechtsschneidend
cutting right

R.01.IK

Bestell-Nr/Order-Number **12-0160**

Anwendungsbereich **Kopierdrehen**
Application **copy turning**



L
linksschneidend
cutting left

L.75

Bestell-Nr/Order-Number **12-0067**

Anwendungsbereich **Kopierdrehen**
Application **copy turning**

Höhenverstellungsschraube
screw to adjust the height

002.00.69

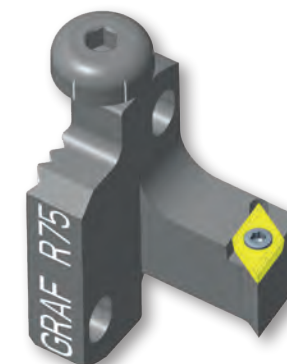

R
rechtsschneidend
cutting right

R.75

Bestell-Nr/Order-Number **12-0066**

Anwendungsbereich **Kopierdrehen**
Application **copy turning**

Wendeplatte
indexable insert

DC.. 07 02 ..

Senkschraube
counter sunk-head screw

001.01.01

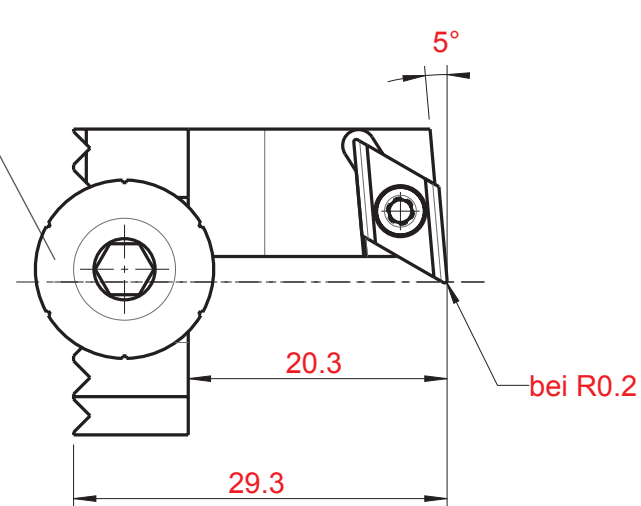

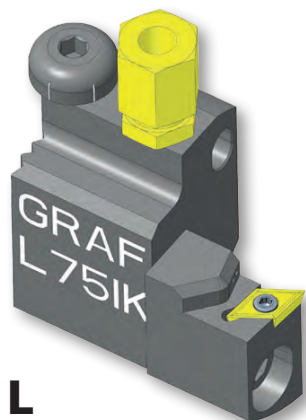

L
linksschneidend
cutting left

L.75.IK

Bestell-Nr/Order-Number **12-1381**

Anwendungsbereich **Kopierdrehen**
Application **copy turning**

Höhenverstellungsschraube
screw to adjust the height

002.00.69

Kühlmittelanschluss
Coolant supply

004.00.19

Wendeplatte
indexable insert

DC.. 0702 ..

Senkschraube
counter sunk-head screw

001.01.01

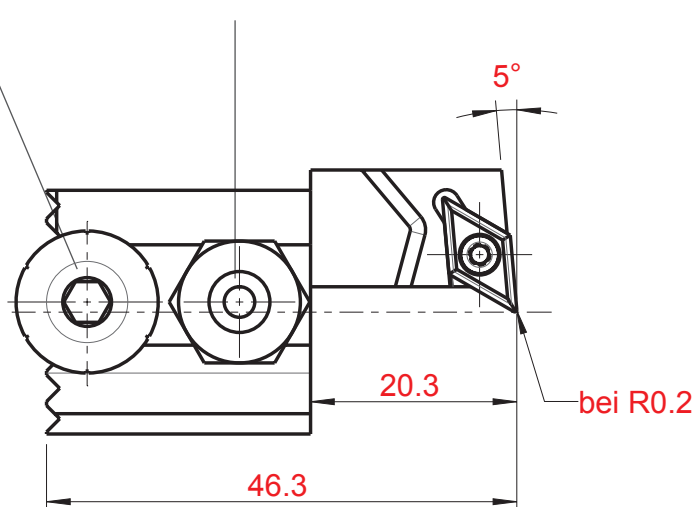

20.3

46.3

5°

bei R0.2

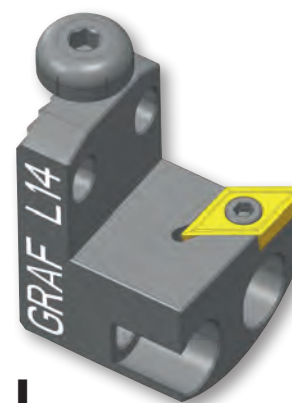

L
linksschneidend
cutting left

L.14

Bestell-Nr/Order-Number **12-0042**

Anwendungsbereich **Kopierdrehen**
Application **copy turning**

Höhenverstellungsschraube
screw to adjust the height

002.00.69



R
rechtsschneidend
cutting right

R.14

Bestell-Nr/Order-Number **12-0041**

Anwendungsbereich **Kopierdrehen**
Application **copy turning**

Wendeplatte
indexable insert

DC.. 11 T3 ..

Senkschraube
counter sunk-head screw

001.01.13

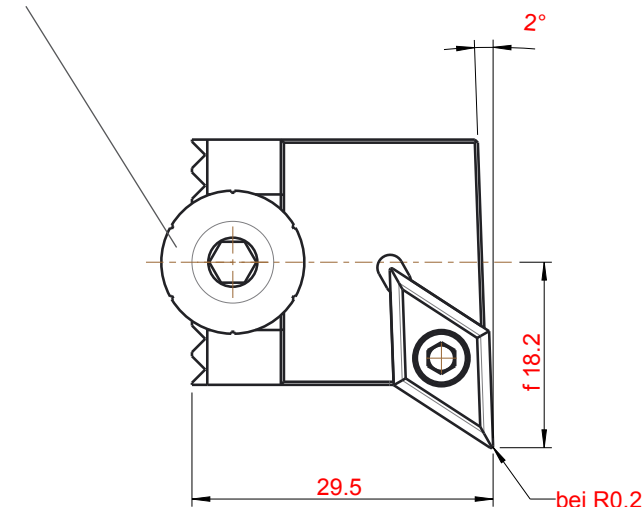

29.5

f 18.2

2°

bei R0.2



L
linksschneidend
cutting left

L.14.IK

Bestell-Nr/Order-Number **12-0143**

Anwendungsbereich **Kopierdrehen**
Application **copy turning**

Höhenverstellungsschraube
screw to adjust the height

002.00.69

Kühlmittelanschluss
Coolant supply

004.00.19

Wendeplatte
indexable insert

DC.. 11 T3 ..

Senkschraube
counter sunk-head screw

001.01.13

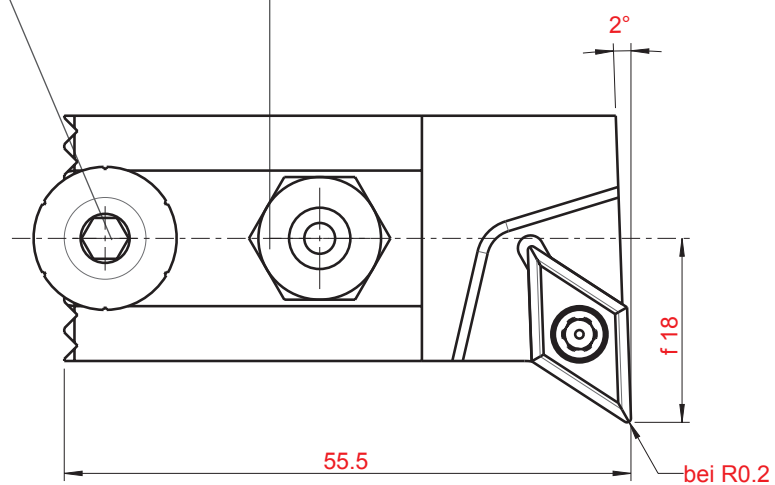

R
rechtsschneidend
cutting right

R.14.IK

Bestell-Nr/Order-Number **12-0142**

Anwendungsbereich **Kopierdrehen**
Application **copy turning**

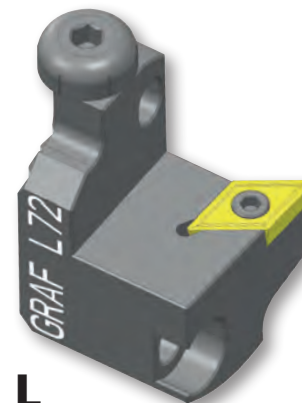

L
linksschneidend
cutting left

L.72

Bestell-Nr/Order-Number **12-0064**

Anwendungsbereich **Kopierdrehen**
Application **copy turning**

Höhenverstellungsschraube
screw to adjust the height

002.00.69

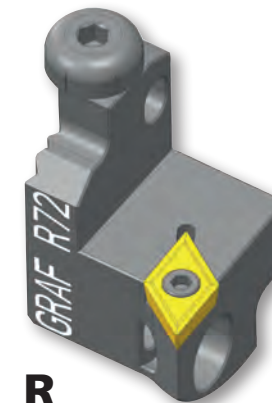

R
rechtsschneidend
cutting right

R.72

Bestell-Nr/Order-Number **12-0063**

Anwendungsbereich **Kopierdrehen**
Application **copy turning**

Wendeplatte
indexable insert

DC.. 11 T3 ..

Senkschraube
counter sunk-head screw

001.01.13

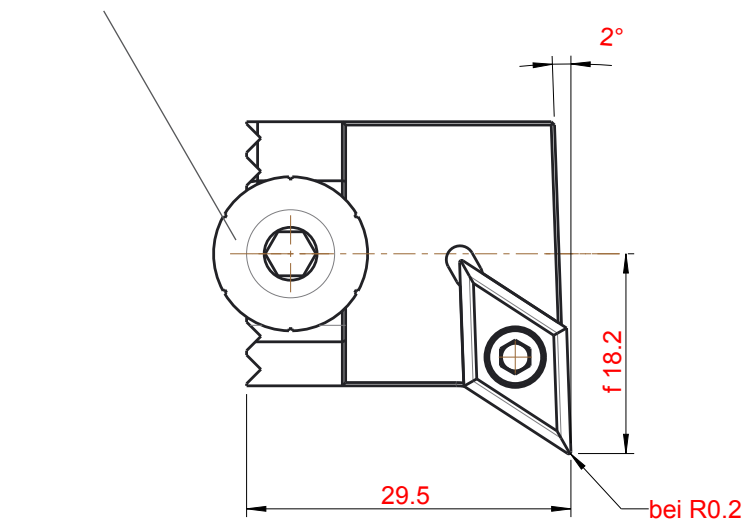



L
linksschneidend
cutting left

L.72.IK

Bestell-Nr/Order-Number **12-1167**

Anwendungsbereich **Kopierdrehen**
Application **copy turning**

Höhenverstellungsschraube
screw to adjust the height

002.00.69

Kühlmittelanschluss
Coolant supply

004.00.19

Wendeplatte
indexable insert

DC.. 11 T3 ..

Senkschraube
counter sunk-head screw

001.01.13

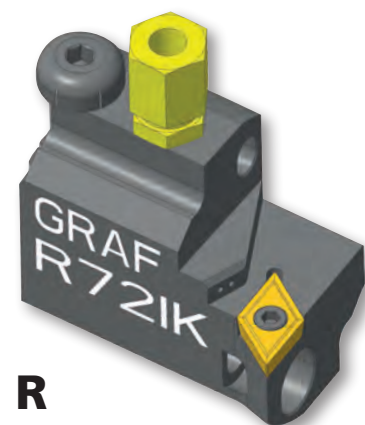
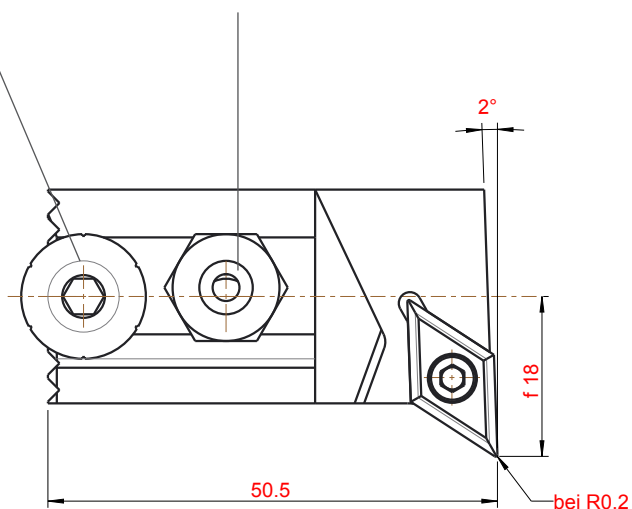

R
rechtsschneidend
cutting right

R.72.IK

Bestell-Nr/Order-Number **12-1166**

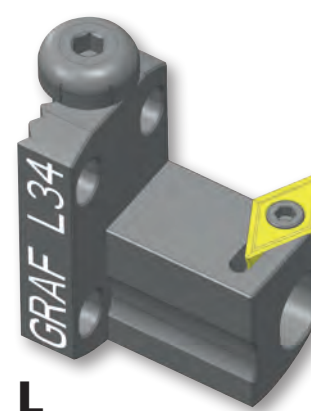

L
linksschneidend
cutting left

L.34

Bestell-Nr/Order-Number **12-1017**

Anwendungsbereich **Kopierdrehen**
Application **copy turning**

Höhenverstellungsschraube
screw to adjust the height

002.00.69

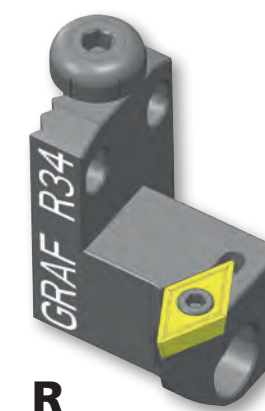

R
rechtsschneidend
cutting right

R.34

Bestell-Nr/Order-Number **12-1016**

Wendeplatte
indexable insert

DC.. 11 T3 ..

Senkschraube
counter sunk-head screw

001.01.15

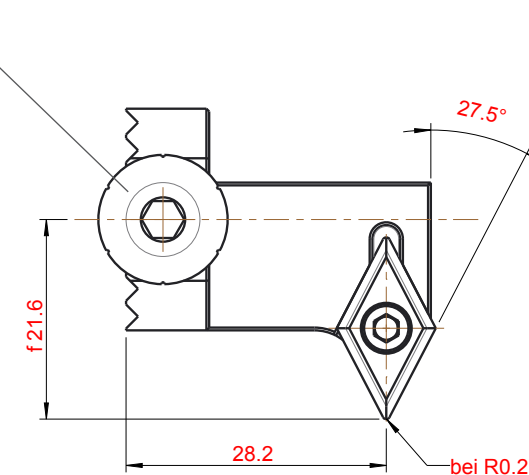



L
linksschneidend
cutting left

L.137

Bestell-Nr/Order-Number **12-1161**

Anwendungsbereich **Kopierdrehen**
Application **copy turning**

Höhenverstellungsschraube
screw to adjust the height

002.00.69

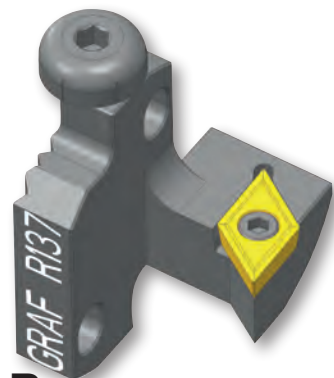

R
rechtsschneidend
cutting right

R.137

Bestell-Nr/Order-Number **12-1160**

Wendeplatte
indexable insert

DC 11 T3..

Senkschraube
counter sunk-head screw

001.01.13

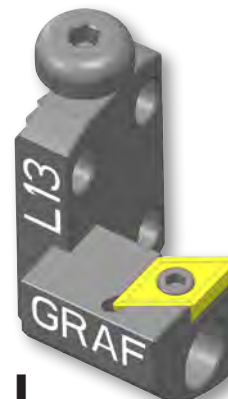
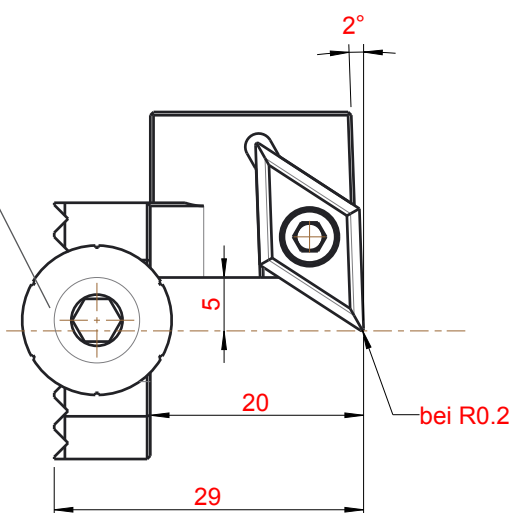

L
linksschneidend
cutting left

L.13

Bestell-Nr/Order-Number **12-0040**

Anwendungsbereich **Kopierdrehen**
Application **copy turning**

Höhenverstellungsschraube
screw to adjust the height

002.00.69

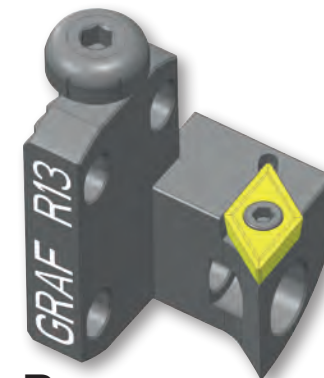

R
rechtsschneidend
cutting right

R.13

Bestell-Nr/Order-Number **12-0039**

Wendeplatte
indexable insert

DC.. 11 T3 ..

Senkschraube
counter sunk-head screw

001.01.13

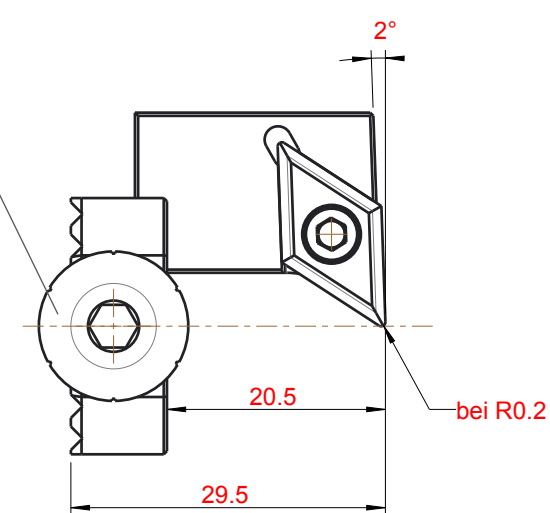



L
linksschneidend
cutting left

L.13.IK

Bestell-Nr/Order-Number **12-1213**

Anwendungsbereich **Kopierdrehen**
Application **copy turning**

Höhenverstellungsschraube
screw to adjust the height

002.00.69

Kühlmittelanschluss
Coolant supply

004.00.19

Wendeplatte
indexable insert

DC.. 11 T3 ..

Senkschraube
counter sunk-head screw

001.01.13

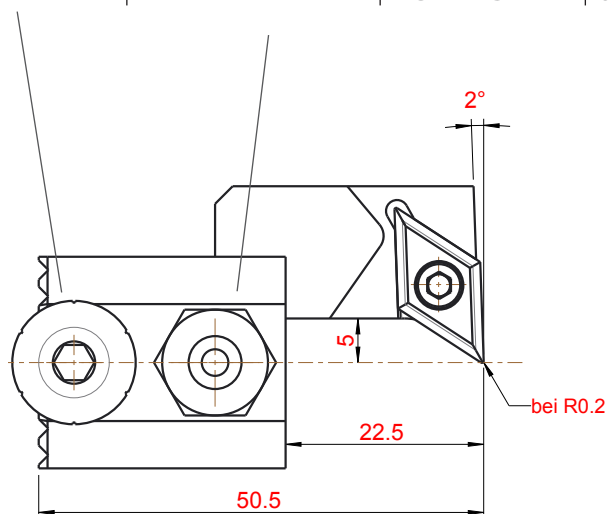

R
rechtsschneidend
cutting right

R.13.IK

Bestell-Nr/Order-Number **12-1212**



L
linksschneidend
cutting left

L.13.XL

Bestell-Nr/Order-Number **12-1308**

Anwendungsbereich **Kopierdrehen**
Application **copy turning**

Höhenverstellungsschraube
screw to adjust the height

002.00.69

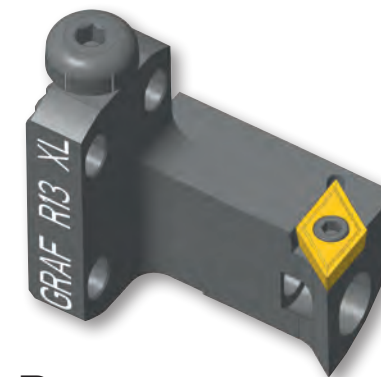

R
rechtsschneidend
cutting right

R.13.XL

Bestell-Nr/Order-Number **12-1307**

Wendeplatte
indexable insert

DC.. 11 T3 ..

Senkschraube
counter sunk-head screw

001.01.13

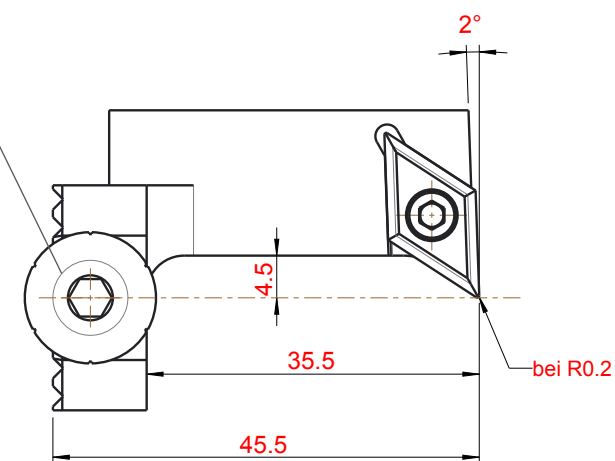

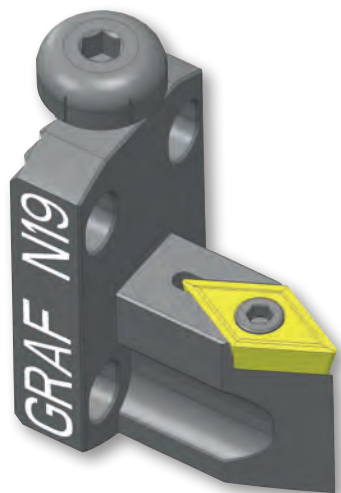

N.19

Bestell-Nr/Order-Number **12-0049**

Anwendungsbereich **Axialdrehen**
Application **face grooving**

Höhenverstellungsschraube
screw to adjust the height

002.00.69

Wendeplatte
indexable insert

DC.. 11 T3 ..

Senkschraube
counter sunk-head screw

001.01.15

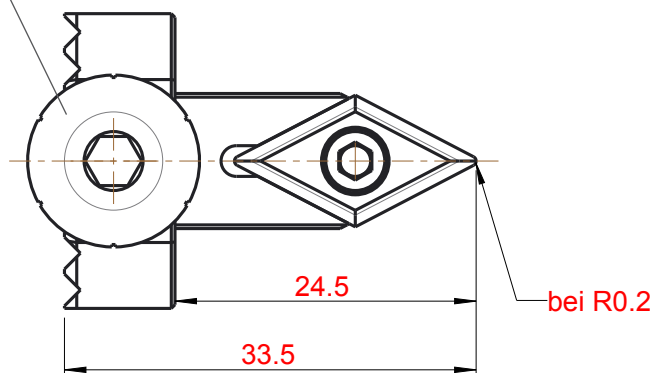

N.19.IK

Bestell-Nr/Order-Number **12-0052**

Anwendungsbereich **Axialdrehen**
Application **face grooving**

Höhenverstellungsschraube
screw to adjust the height

002.00.69

Kühlmittelanschluss
Coolant supply

004.00.19

Wendeplatte
indexable insert

DC.. 11 T3 ..

Senkschraube
counter sunk-head screw

001.01.15

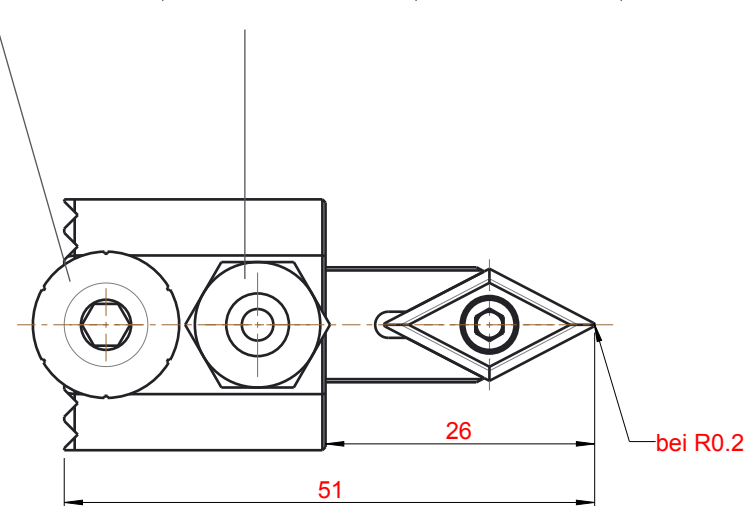

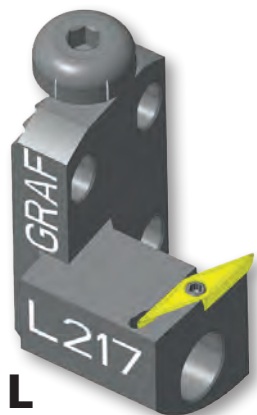

L
linksschneidend
cutting left

L.217

Bestell-Nr/Order-Number **12-1357**

Anwendungsbereich **Kopierdrehen**
Application **copy turning**

Höhenverstellungsschraube
screw to adjust the height

002.00.69

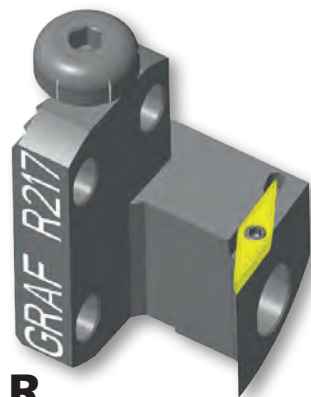

R
linksschneidend
cutting left

R.217

Bestell-Nr/Order-Number **12-1356**

Anwendungsbereich **Kopierdrehen**
Application **copy turning**

Wendeplatte
indexable insert

YW.. 11.T2 ..

Senkschraube
counter sunk-head screw

001.01.25

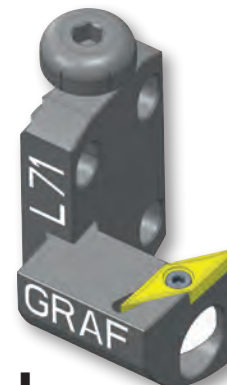
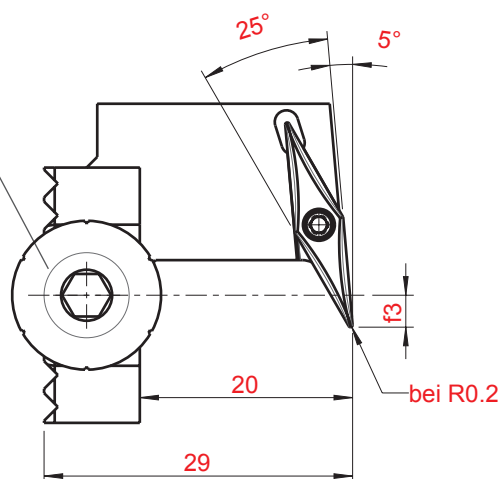

L
linksschneidend
cutting left

L.71

Bestell-Nr/Order-Number **12-0061**

Anwendungsbereich **Kopierdrehen**
Application **copy turning**

Höhenverstellungsschraube
screw to adjust the height

002.00.69

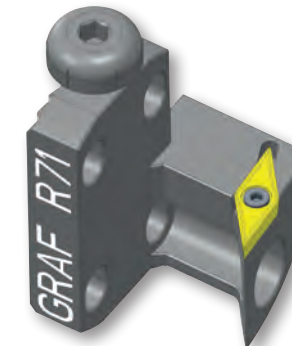

R
linksschneidend
cutting left

R.71

Bestell-Nr/Order-Number **12-0060**

Anwendungsbereich **Kopierdrehen**
Application **copy turning**

Wendeplatte
indexable insert

VB.. 11.03 ..

Senkschraube
counter sunk-head screw

001.01.08

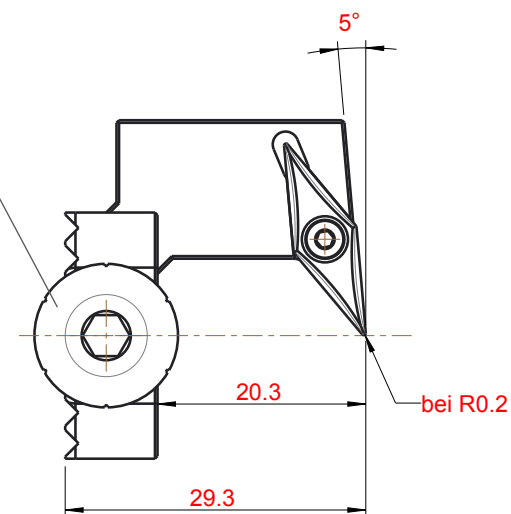

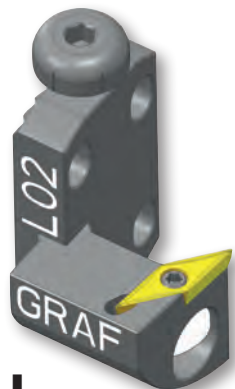

L
linksschneidend
cutting left

L.02

Bestell-Nr/Order-Number **12-0025**

Anwendungsbereich **Kopierdrehen**
Application **copy turning**

Höhenverstellungsschraube
screw to adjust the height

002.00.69

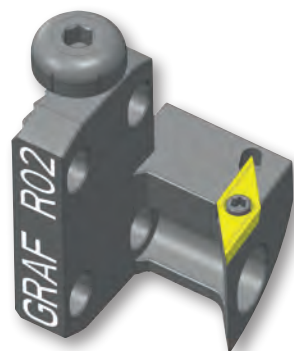

R
rechtsschneidend
cutting right

R.02

Bestell-Nr/Order-Number **12-0024**

Wendeplatte
indexable insert

VC.. 11 03..

Senkschraube
counter sunk-head screw

001.01.08

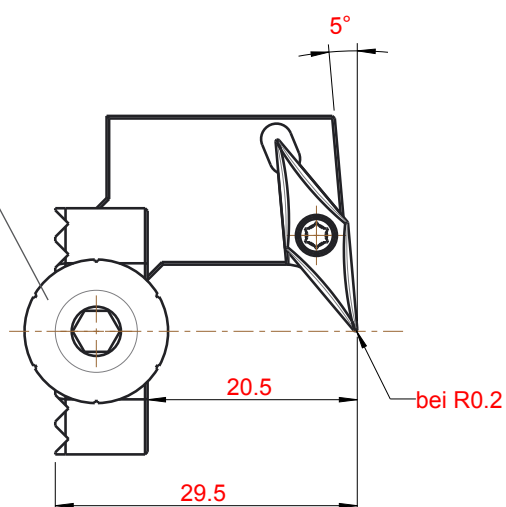

L
linksschneidend
cutting left

L.02.IK

Bestell-Nr/Order-Number **12-1310**

Anwendungsbereich **Kopierdrehen**
Application **copy turning**

Höhenverstellungsschraube
screw to adjust the height

002.00.69

Kühlmittelanschluss
Coolant supply

004.00.19

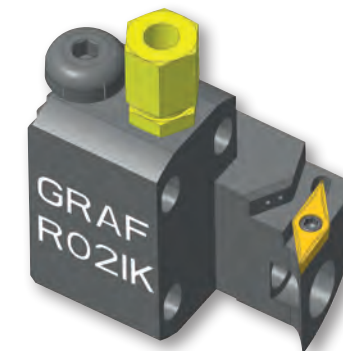

R
rechtsschneidend
cutting right

R.02.IK

Bestell-Nr/Order-Number **12-1309**

Wendeplatte
indexable insert

VC.. 11 03..

Senkschraube
counter sunk-head screw

001.01.08

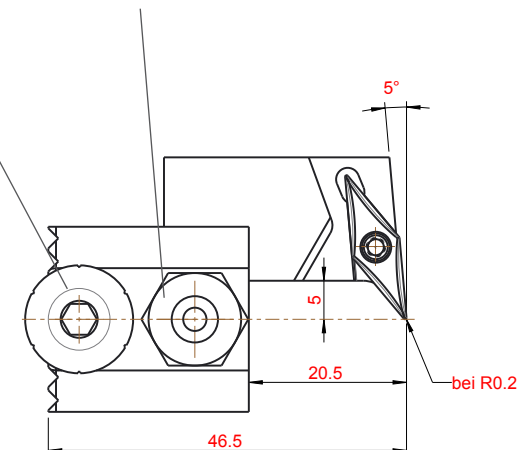

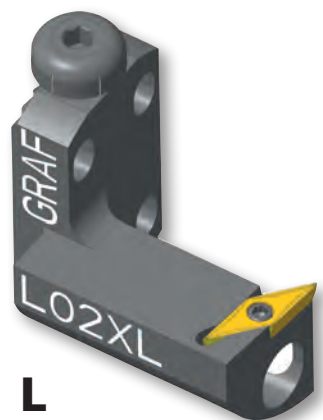

L
linksschneidend
cutting left

L.02.XL

Bestell-Nr/Order-Number **12-1312**

Anwendungsbereich **Kopierdrehen**
Application **copy turning**

Höhenverstellungsschraube
screw to adjust the height

002.00.69

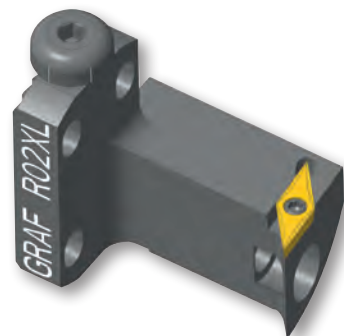

R
rechtsschneidend
cutting right

R.02.XL

Bestell-Nr/Order-Number **12-1311**

Anwendungsbereich **Kopierdrehen**
Application **copy turning**

Wendeplatte
indexable insert

VC.. 11 03..

Senkschraube
counter sunk-head screw

001.01.08

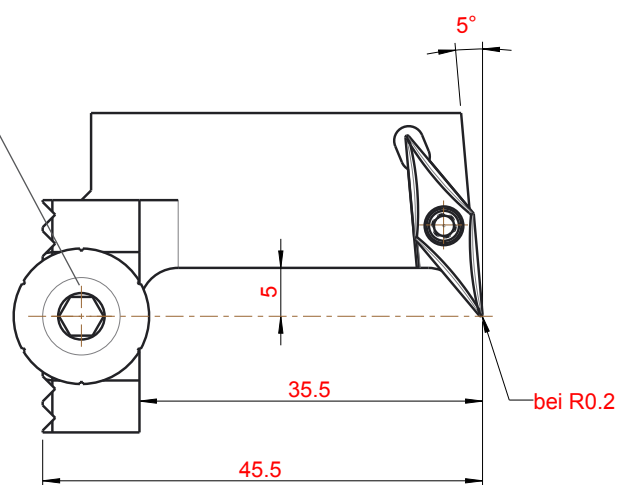

L
linksschneidend
cutting left

L.28

Bestell-Nr/Order-Number **12-1383**

Anwendungsbereich **Kopierdrehen**
Application **copy turning**

Höhenverstellungsschraube
screw to adjust the height

002.00.69



R
rechtsschneidend
cutting right

R.28

Bestell-Nr/Order-Number **12-13820**

Anwendungsbereich **Kopierdrehen**
Application **copy turning**

Wendeplatte
indexable insert

VC.. 11 03..

Senkschraube
counter sunk-head screw

001.01.08

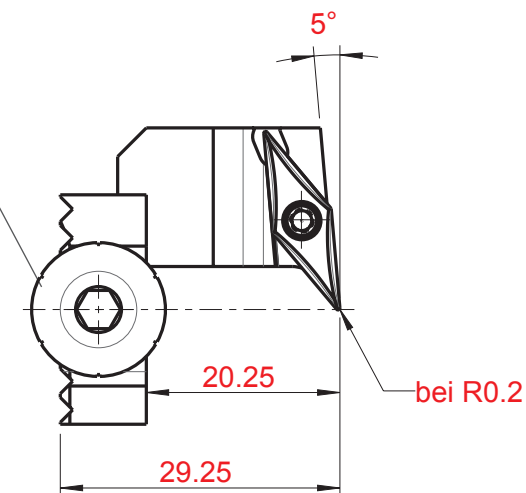

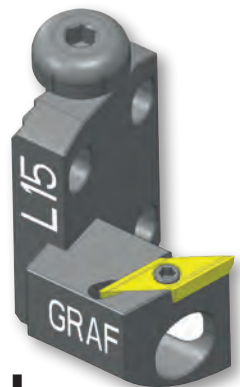

L
linksschneidend
cutting left

L.15
Bestell-Nr/Order-Number **12-0044**

Anwendungsbereich **Kopierdrehen**
Application **copy turning**

Höhenverstellungsschraube
screw to adjust the height
002.00.69

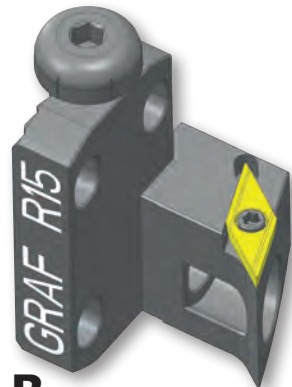

R
rechtsschneidend
cutting right

R.15
Bestell-Nr/Order-Number **12-0043**

Anwendungsbereich **Kopierdrehen**
Application **copy turning**

Wendeplatte
indexable insert
VC.. 11 03..
Senkschraube
counter sunk-head screw
001.01.08

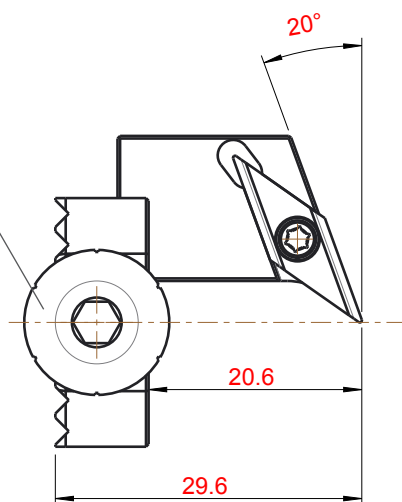

L
linksschneidend
cutting left

L.96
Bestell-Nr/Order-Number **12-0092**

Anwendungsbereich **Kopierdrehen**
Application **copy turning**

Höhenverstellungsschraube
screw to adjust the height
002.00.69



R
rechtsschneidend
cutting right

R.96
Bestell-Nr/Order-Number **12-0082**

Anwendungsbereich **Kopierdrehen**
Application **copy turning**

Wendeplatte
indexable insert
VC.. 11.03..
Senkschraube
counter sunk-head screw
001.01.08

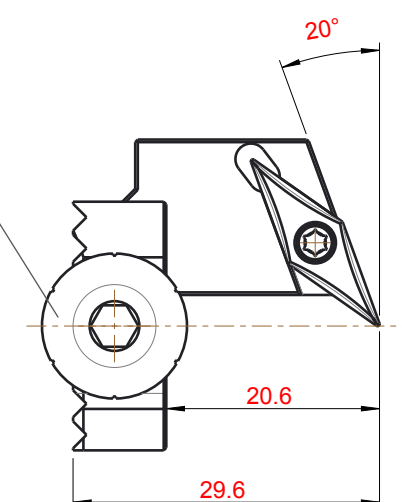

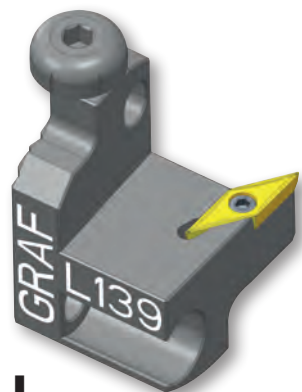

L
linksschneidend
cutting left

L.139

Bestell-Nr/Order-Number **12-1165**

Anwendungsbereich **Kopierdrehen**
Application **copy turning**

Höhenverstellungsschraube
screw to adjust the height

002.00.69

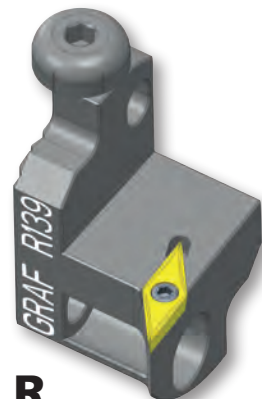

R
rechtsschneidend
cutting right

R.139

Bestell-Nr/Order-Number **12-1164**

Anwendungsbereich **Kopierdrehen**
Application **copy turning**

Wendeplatte
indexable insert

VC.. 11.03..

Senkschraube
counter sunk-head screw

001.01.08

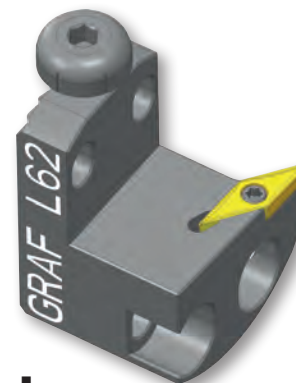
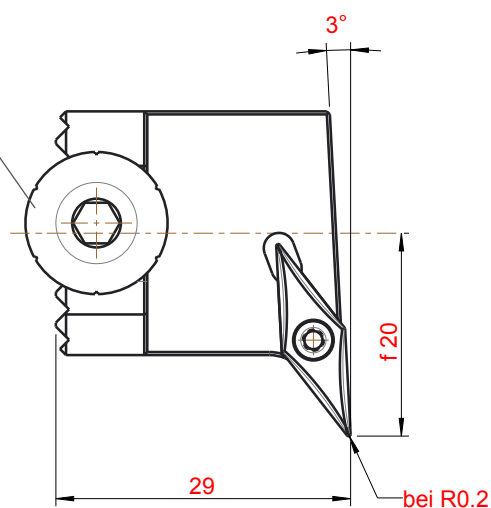

L
linksschneidend
cutting left

L.62

Bestell-Nr/Order-Number **12-0500**

Anwendungsbereich **Kopierdrehen**
Application **copy turning**

Höhenverstellungsschraube
screw to adjust the height

002.00.69

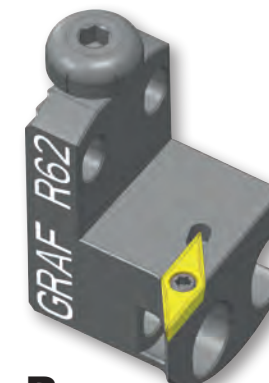

R
rechtsschneidend
cutting right

R.62

Bestell-Nr/Order-Number **12-0484**

Anwendungsbereich **Kopierdrehen**
Application **copy turning**

Wendeplatte
indexable insert

VC.. 11.03..

Senkschraube
counter sunk-head screw

001.01.08

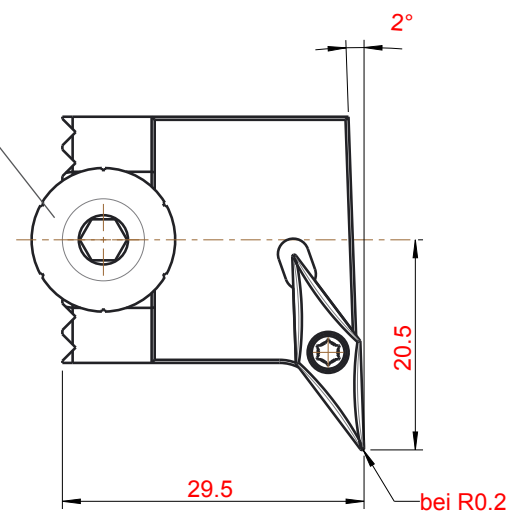



L
linksschneidend
cutting left

L.62.IK

Bestell-Nr/Order-Number **12-0530**

Anwendungsbereich **Kopierdrehen**
Application **copy turning**

Höhenverstellungsschraube
screw to adjust the height

002.00.69

Kühlmittelanschluss
Coolant supply

004.00.19

Wendeplatte
indexable insert

VC.. 11.03 ..

Senkschraube
counter sunk-head screw

001.01.08

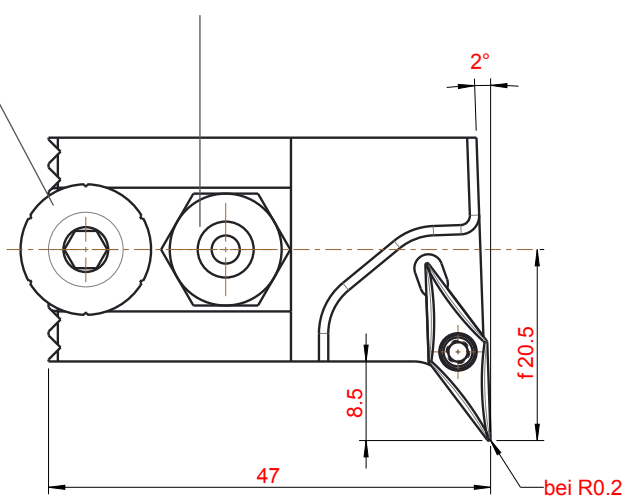

R
rechtsschneidend
cutting right

R.62.IK

Bestell-Nr/Order-Number **12-0529**

Anwendungsbereich **Kopierdrehen**
Application **copy turning**



L
linksschneidend
cutting left

L.60

Bestell-Nr/Order-Number **12-1149**

Anwendungsbereich **Kopierdrehen**
Application **copy turning**

Höhenverstellungsschraube
screw to adjust the height

002.00.69

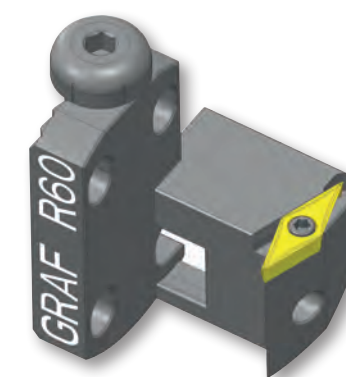

R
rechtsschneidend
cutting right

R.60

Bestell-Nr/Order-Number **12-0482**

Anwendungsbereich **Kopierdrehen**
Application **copy turning**

Wendeplatte
indexable insert

VC.. 11.03 ..

Senkschraube
counter sunk-head screw

001.01.08

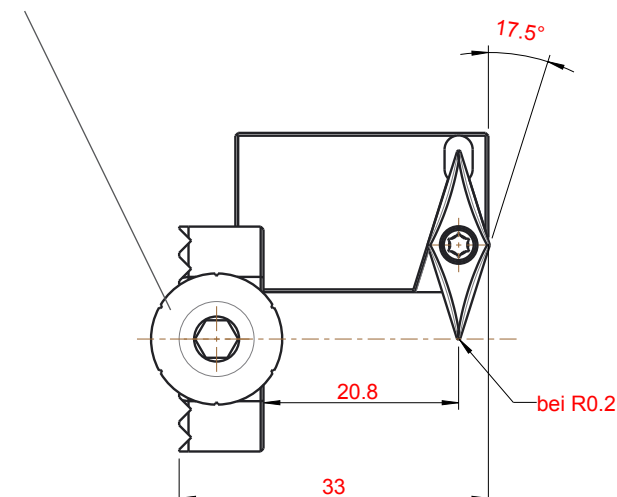

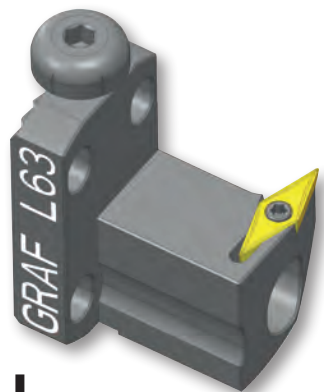

L
linksschneidend
cutting left

L.63

Bestell-Nr/Order-Number **12-0086**

Anwendungsbereich **Kopierdrehen**
Application **copy turning**

Höhenverstellungsschraube
screw to adjust the height

002.00.69



R
rechtsschneidend
cutting right

R.63

Bestell-Nr/Order-Number **12-0485**

Anwendungsbereich **Kopierdrehen**
Application **copy turning**

Wendeplatte
indexable insert

VC.. 11.03 ..

Senkschraube
counter sunk-head screw

001.01.08

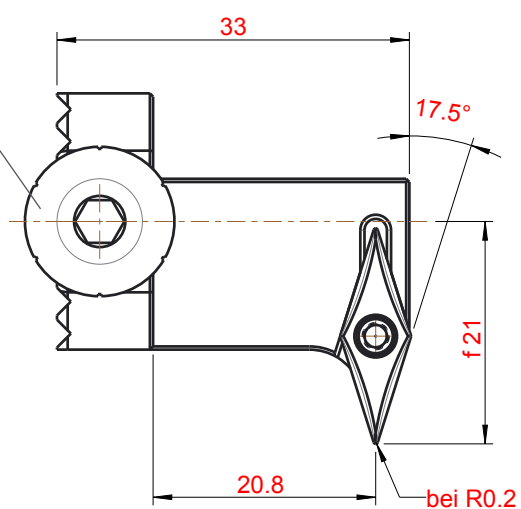

L
linksschneidend
cutting left

L.40.IK

Bestell-Nr/Order-Number **12-1431**

Anwendungsbereich **Axialdrehen**
Application **face grooving**

Höhenverstellungsschraube
screw to adjust the height

002.00.69

Kühlmittelanschluss
Coolant supply

004.00.19



R
rechtsschneidend
cutting right

R.40.IK

Bestell-Nr/Order-Number **12-1430**

Anwendungsbereich **Axialdrehen**
Application **face grooving**

Wendeplatte
indexable insert

VC.. 11 03 ..

Senkschraube
counter sunk-head screw

001.01.08

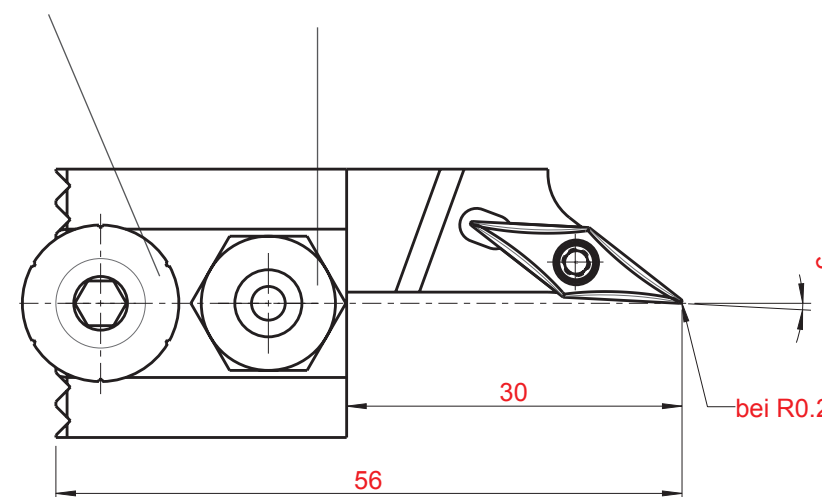

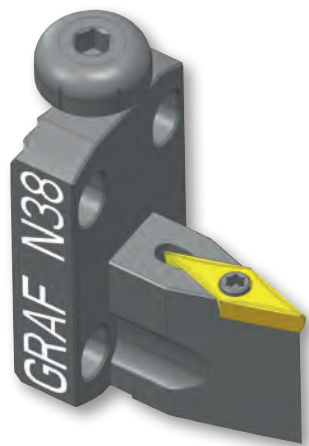

N.38

Bestell-Nr/Order-Number **12-0478**

Anwendungsbereich **Axialdrehen**
Application **face grooving**

Höhenverstellungsschraube
screw to adjust the height

002.00.69

Wendeplatte
indexable insert

VC..11 03...

Senkschraube
counter sunk-head screw

001.01.08

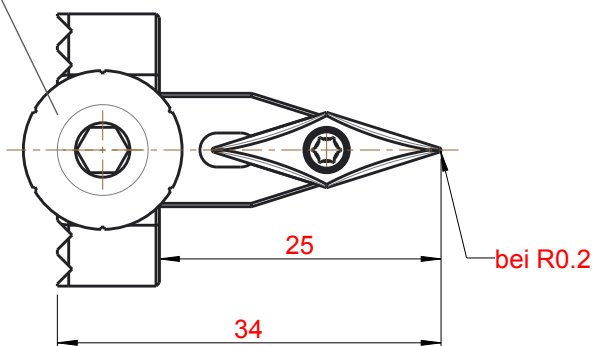

N.38.IK

Bestell-Nr/Order-Number **12-0480**

Anwendungsbereich **Axialdrehen**
Application **face grooving**

Höhenverstellungsschraube
screw to adjust the height

002.00.69

Kühlmittelanschluss
Coolant supply

004.00.19

Wendeplatte
indexable insert

VC.. 11 03 ..

Senkschraube
counter sunk-head screw

001.01.15

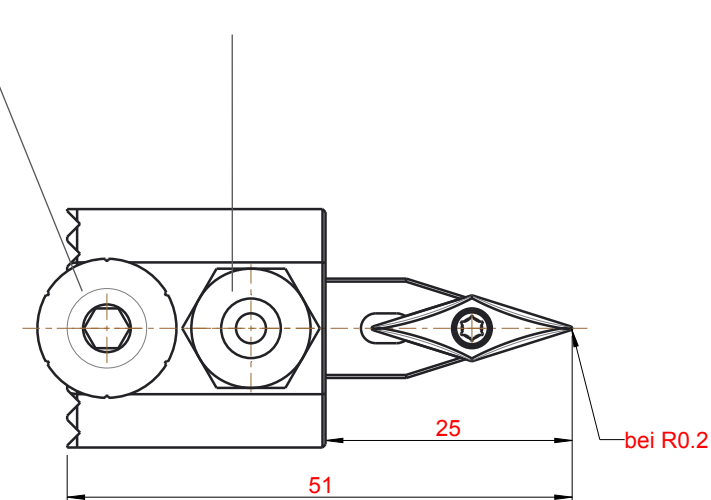

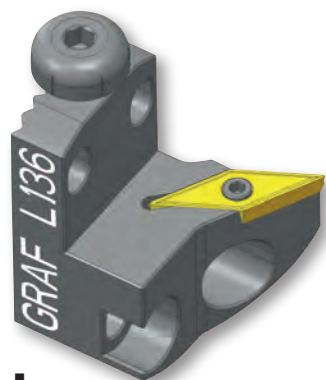

L
linksschneidend
cutting left

L.136

Bestell-Nr/Order-Number **12-1159**

Anwendungsbereich **Kopierdrehen**
Application **copy turning**

Höhenverstellungsschraube
screw to adjust the height

002.00.69

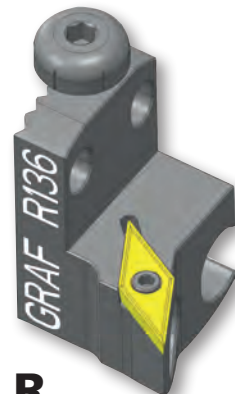

R
rechtsschneidend
cutting right

R.136

Bestell-Nr/Order-Number **12-1074**

Anwendungsbereich **Kopierdrehen**
Application **copy turning**

Wendeplatte
indexable insert

VC.. 13 03

Senkschraube
counter sunk-head screw

001.01.07

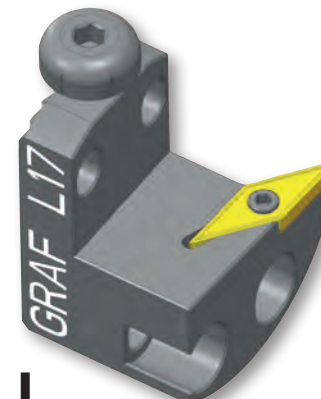
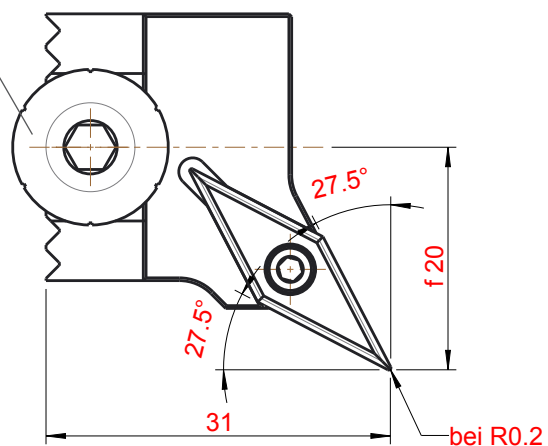

L
linksschneidend
cutting left

L.17

Bestell-Nr/Order-Number **12-0378**

Anwendungsbereich **Kopierdrehen**
Application **copy turning**

Höhenverstellungsschraube
screw to adjust the height

002.00.69

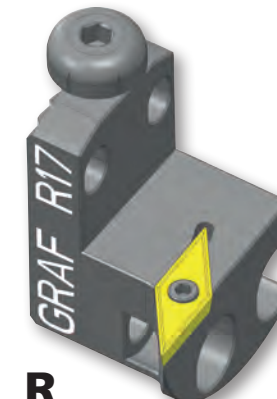

R
rechtsschneidend
cutting right

R.17

Bestell-Nr/Order-Number **12-0377**

Anwendungsbereich **Kopierdrehen**
Application **copy turning**

Wendeplatte
indexable insert

VC.. 13 03 ..

Senkschraube
counter sunk-head screw

001.01.07

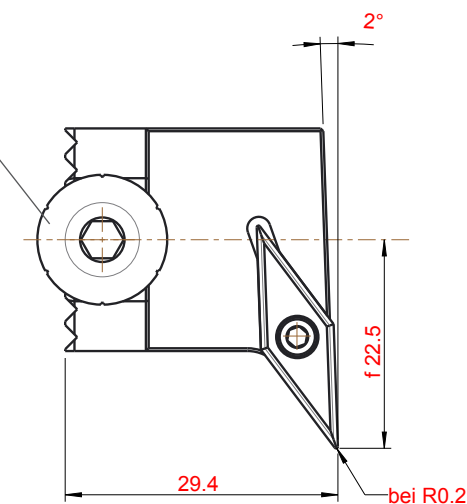



L
linksschneidend
cutting left

R
rechtsschneidend
cutting right

L.17.IK

Bestell-Nr/Order-Number **12-0146**

R.17.IK

Bestell-Nr/Order-Number **12-0145**

Anwendungsbereich **Kopierdrehen**
Application **copy turning**

Höhenverstellungsschraube
screw to adjust the height

Kühlmittelanschluss
Coolant supply

Wendeplatte
indexable insert

Senkschraube
counter sunk-head screw

002.00.69

004.00.19

VC.. 13 03..

001.01.07

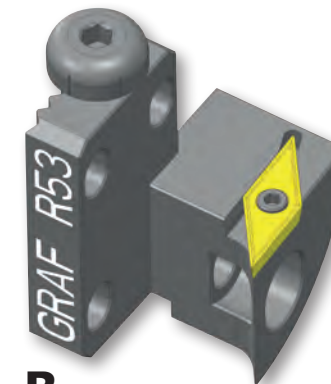
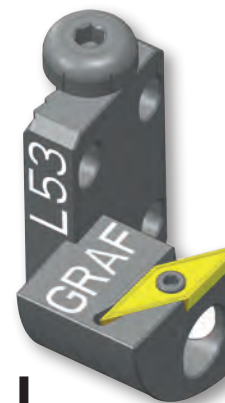
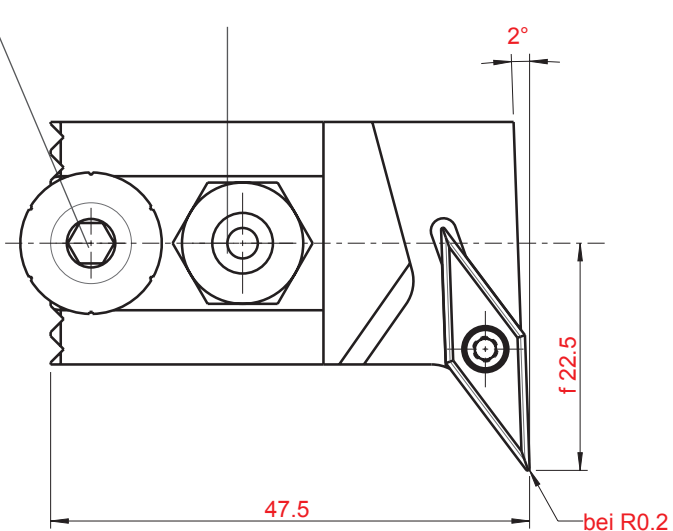

L
linksschneidend
cutting left

R
rechtsschneidend
cutting right

L.53

Bestell-Nr/Order-Number **12-0335**

R.53

Bestell-Nr/Order-Number **12-0333**

Anwendungsbereich **Kopierdrehen**
Application **copy turning**

Höhenverstellungsschraube
screw to adjust the height

Wendeplatte
indexable insert

Senkschraube
counter sunk-head screw

002.00.69

VC.. 13 03..

001.01.07

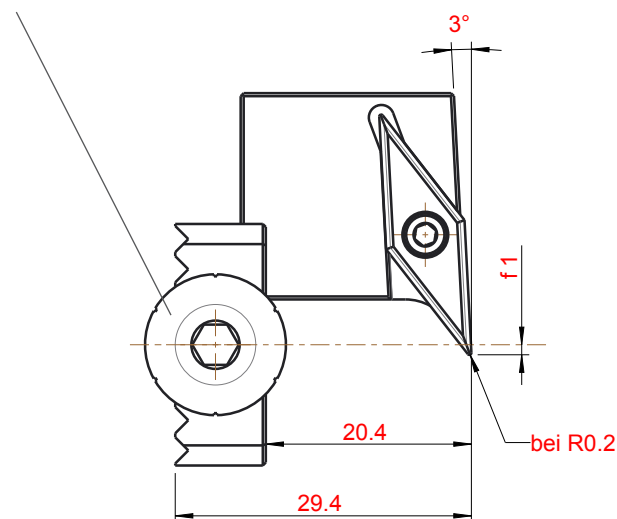

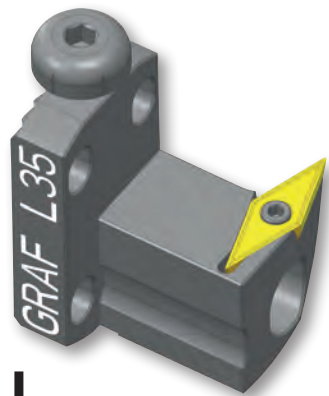

L
linksschneidend
cutting left

L.35

Bestell-Nr/Order-Number **12-0344**

Anwendungsbereich **Kopierdrehen**
Application **copy turning**

Höhenverstellungsschraube
screw to adjust the height

002.00.69

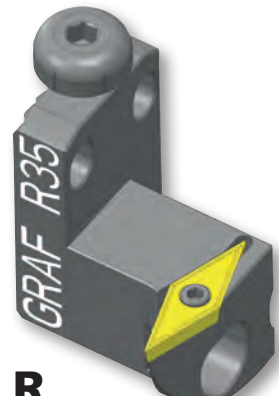

R
rechtsschneidend
cutting right

R.35

Bestell-Nr/Order-Number **12-0330**

Wendeplatte
indexable insert

VC.. 13 03 ..

Senkschraube
counter sunk-head screw

001.01.07

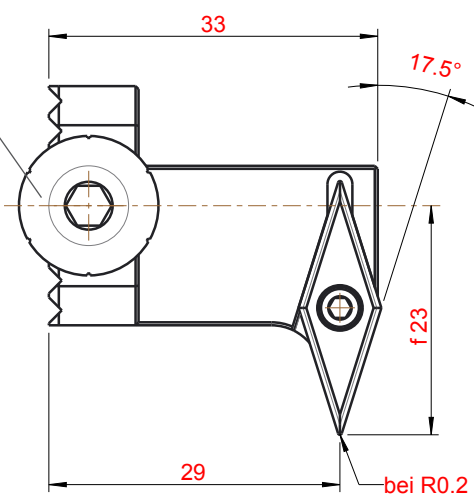

L
linksschneidend
cutting left

L.29

Bestell-Nr/Order-Number **12-0262**

Anwendungsbereich **Axialdrehen**
Application **face grooving**

Höhenverstellungsschraube
screw to adjust the height

002.00.69

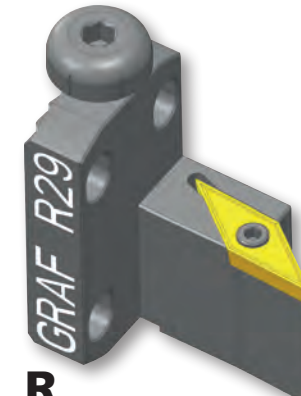

R
rechtsschneidend
cutting right

R.29

Bestell-Nr/Order-Number **12-0261**

Wendeplatte
indexable insert

VC.. 13 03 ..

Senkschraube
counter sunk-head screw

001.01.07

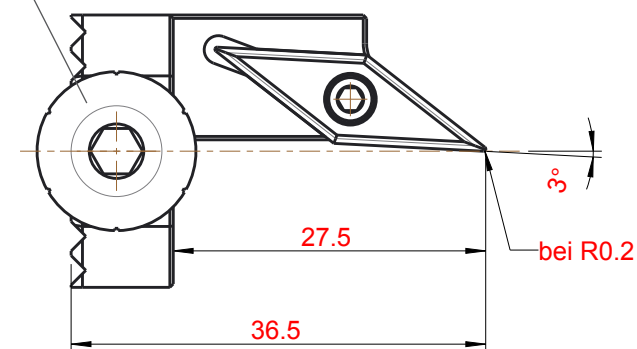



L
linksschneidend
cutting left

L.29.IK

Bestell-Nr/Order-Number **12-1067**

Anwendungsbereich **Axialdrehen**
Application **face grooving**

Höhenverstellungsschraube
screw to adjust the height

002.00.69

Kühlmittelanschluss
Coolant supply

004.00.19

Wendeplatte
indexable insert

VC.. 13 03 ..

Senkschraube
counter sunk-head screw

001.01.07

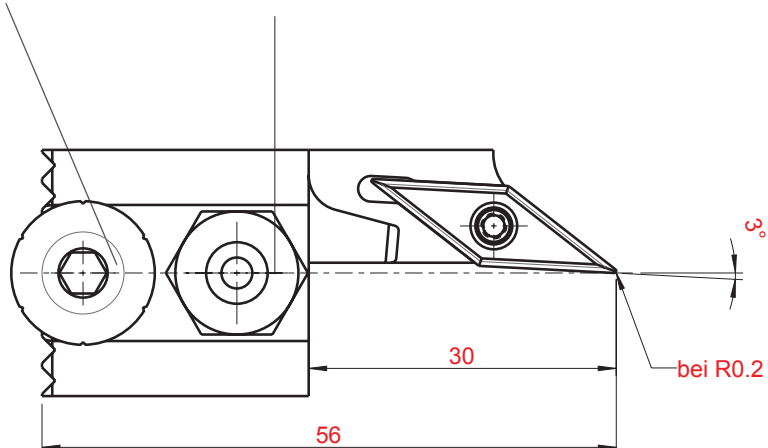

R
rechtsschneidend
cutting right

R.29.IK

Bestell-Nr/Order-Number **12-1066**



L
linksschneidend
cutting left

L.97

Bestell-Nr/Order-Number **12-1070**

Anwendungsbereich **Axialdrehen**
Application **face grooving**

Höhenverstellungsschraube
screw to adjust the height

002.00.69

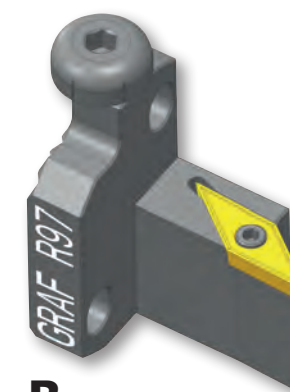

R
rechtsschneidend
cutting right

R.97

Bestell-Nr/Order-Number **12-0083**

Wendeplatte
indexable insert

VC.. 13 03 ..

Senkschraube
counter sunk-head screw

001.01.07

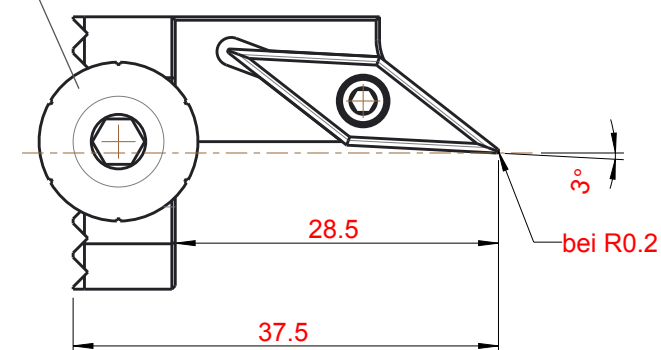

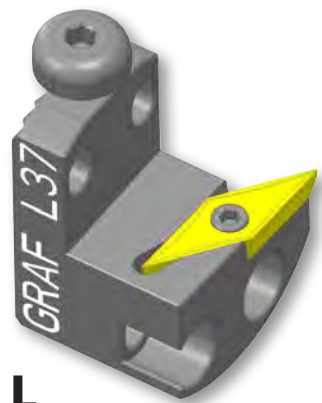

L
linksschneidend
cutting left

L.37

Bestell-Nr/Order-Number **12-0452**

Anwendungsbereich **Kopierdrehen**
Application **copy turning**

Höhenverstellungsschraube
screw to adjust the height

002.00.69

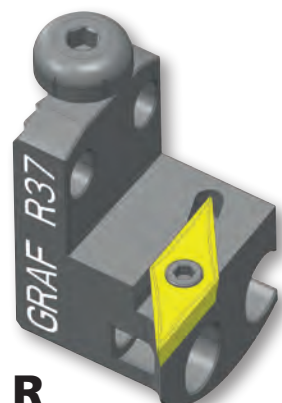

R
rechtsschneidend
cutting right

R.37

Bestell-Nr/Order-Number **12-0449**

Wendeplatte
indexable insert

VC.. 16 04 ..

Senkschraube
counter sunk-head screw

001.01.15

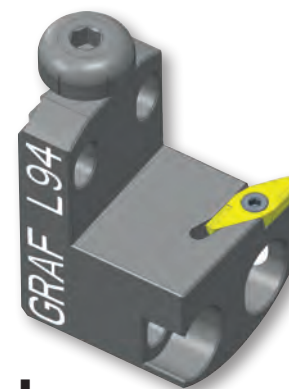
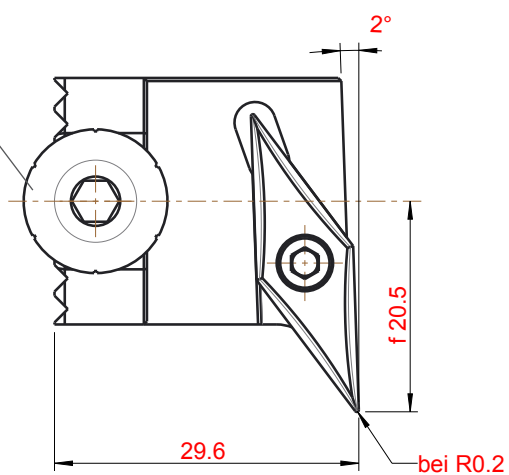

L
linksschneidend
cutting left

L.94

Bestell-Nr/Order-Number **12-1151**

Anwendungsbereich **Langdrehen**
Application **turning**

Höhenverstellungsschraube
screw to adjust the height

002.00.69

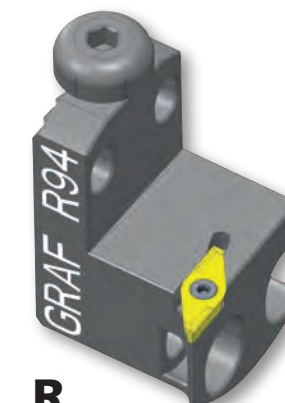

R
rechtsschneidend
cutting right

R.94

Bestell-Nr/Order-Number **12-0532**

Wendeplatte
indexable insert

VP.. 10 03 .. UTILIS

Senkschraube
counter sunk-head screw

001.01.33

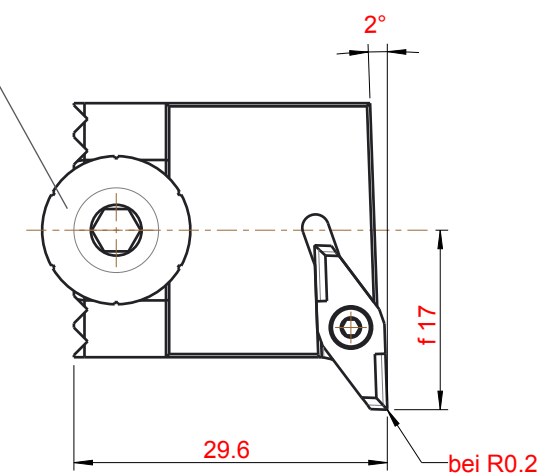

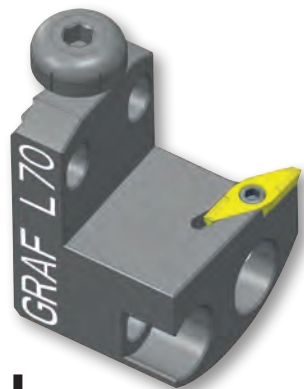

L
linksschneidend
cutting left

L.70

Bestell-Nr/Order-Number **12-1043**

Anwendungsbereich **Langdrehen**
Application **turning**

Höhenverstellungsschraube
screw to adjust the height

002.00.69

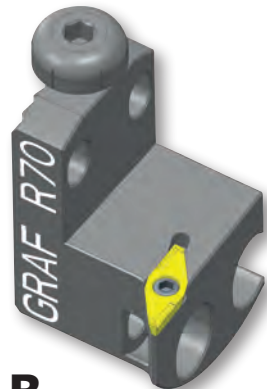

R
rechtsschneidend
cutting right

R.70

Bestell-Nr/Order-Number **12-0514**

Wendeplatte
indexable insert

Applitec Typ 300

Senkschraube
counter sunk-head screw

001.01.33

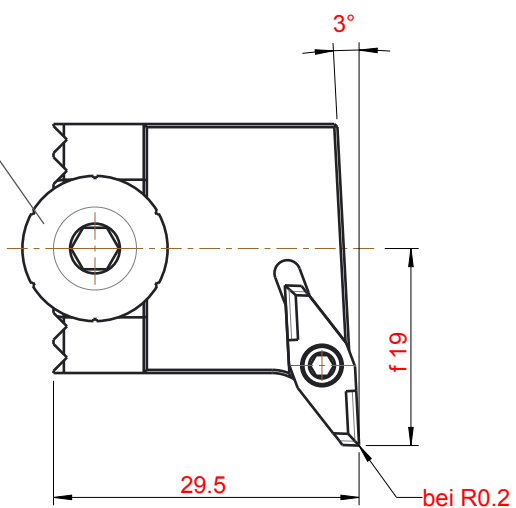

L
linksschneidend
cutting left

L.70.IK

Bestell-Nr/Order-Number **12-0520**

Anwendungsbereich **Langdrehen**
Application **turning**

Höhenverstellungsschraube
screw to adjust the height

002.00.69

Kühlmittelanschluss
Coolant supply

004.00.19

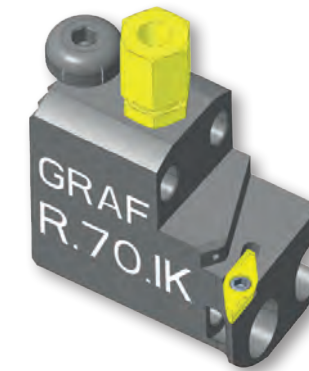

R
rechtsschneidend
cutting right

R.70.IK

Bestell-Nr/Order-Number **12-0515**

Wendeplatte
indexable insert

Applitec Typ 300

Senkschraube
counter sunk-head screw

001.01.33

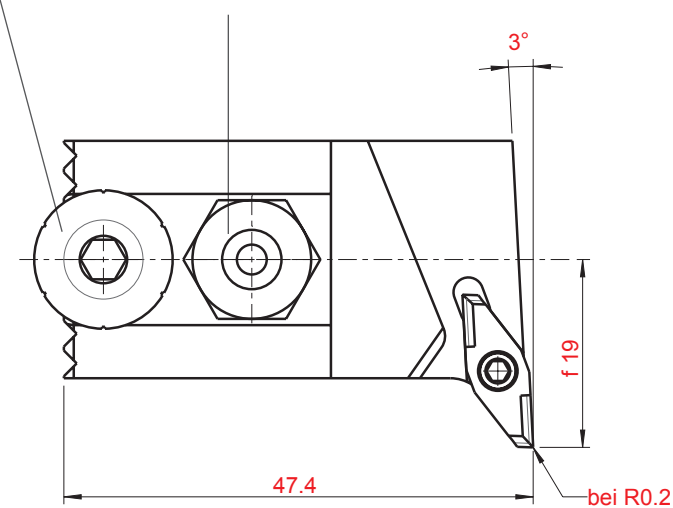

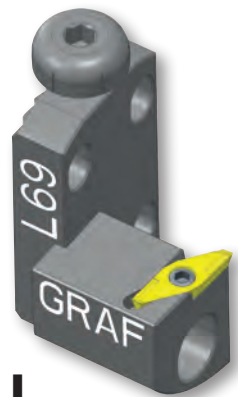

L
linksschneidend
cutting left

L.69

Bestell-Nr/Order-Number **12-1036**

Anwendungsbereich **Langdrehen**
Application **turning**

Höhenverstellungsschraube
screw to adjust the height

002.00.69



R
rechtsschneidend
cutting right

R.69

Bestell-Nr/Order-Number **12-0513**

Wendeplatte
indexable insert

Applitec Typ 300

001.01.33

Senkschraube
counter sunk-head screw

001.01.33

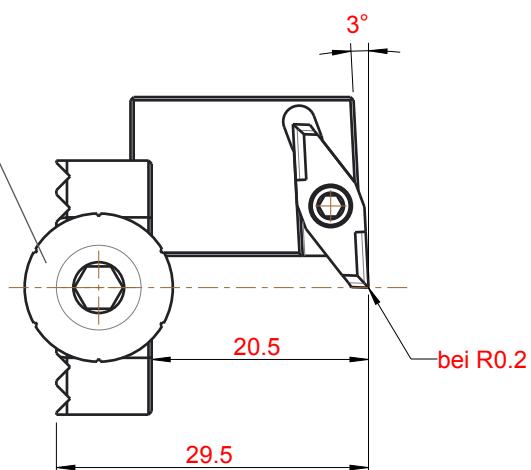

L
linksschneidend
cutting left

L.138

Bestell-Nr/Order-Number **12-1163**

Anwendungsbereich **Langdrehen**
Application **turning**

Höhenverstellungsschraube
screw to adjust the height

002.00.69

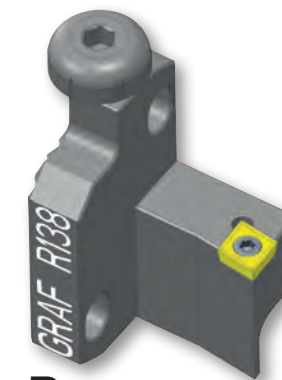

R
rechtsschneidend
cutting right

R.138

Bestell-Nr/Order-Number **12-1162**

Wendeplatte
indexable insert

CC.. 06 02..

Senkschraube
counter sunk-head screw

001.01.01

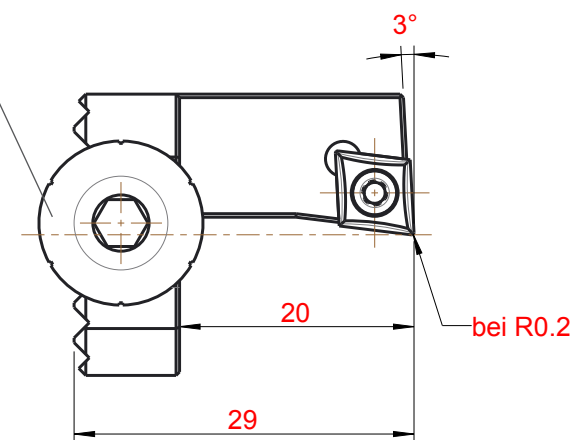

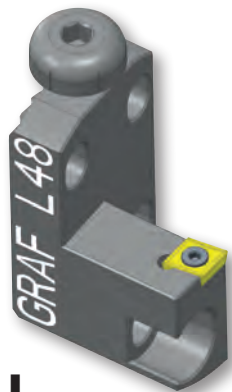

L
linksschneidend
cutting left

L.48

Bestell-Nr/Order-Number **12-0483**

Anwendungsbereich **Langdrehen**
Application **turning**

Höhenverstellungsschraube
screw to adjust the height

002.00.69

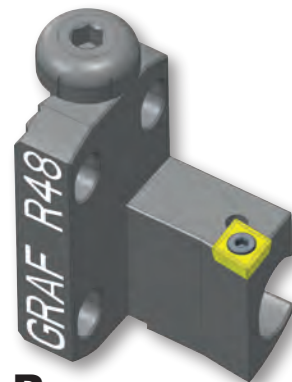

R
rechtsschneidend
cutting right

R.48

Bestell-Nr/Order-Number **12-0467**

Anwendungsbereich **Langdrehen**
Application **turning**

Wendeplatte
indexable insert

CC.. 06 02 ..

Senkschraube
counter sunk-head screw

001.01.01

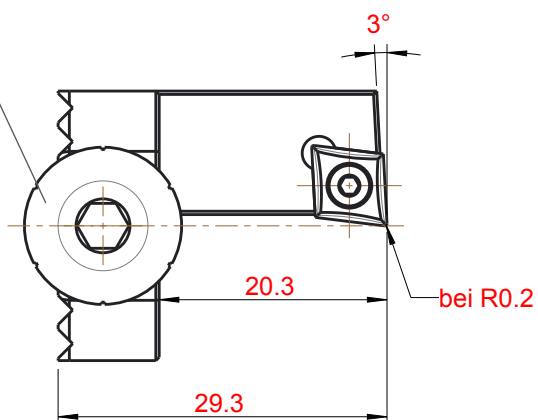

L
linksschneidend
cutting left

L.48.IK

Bestell-Nr/Order-Number **12-1152**

Anwendungsbereich **Langdrehen**
Application **turning**

Höhenverstellungsschraube
screw to adjust the height

002.00.69

Kühlmittelanschluss
Coolant supply

004.00.19



R
rechtsschneidend
cutting right

R.48.IK

Bestell-Nr/Order-Number **12-0549**

Anwendungsbereich **Langdrehen**
Application **turning**

Wendeplatte
indexable insert

CC.. 06 02..

Senkschraube
counter sunk-head screw

001.01.01

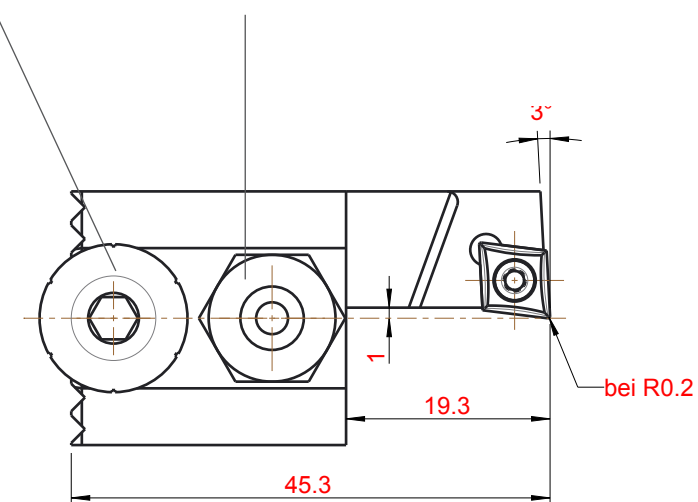

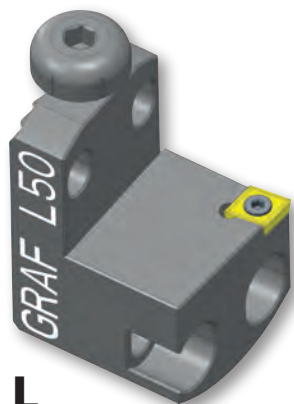

L
linksschneidend
cutting left

L.50

Bestell-Nr/Order-Number **12-0516**

Anwendungsbereich **Langdrehen**
Application **turning**

Höhenverstellungsschraube
screw to adjust the height

002.00.69

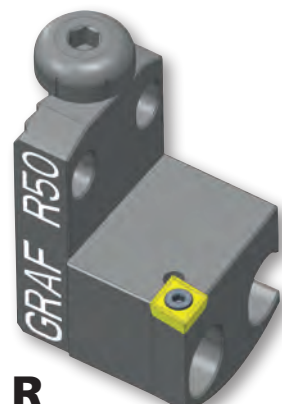

R
rechtsschneidend
cutting right

R.50

Bestell-Nr/Order-Number **12-0499**

Wendeplatte
indexable insert

CC.. 06 02..

Senkschraube
counter sunk-head screw

001.01.01

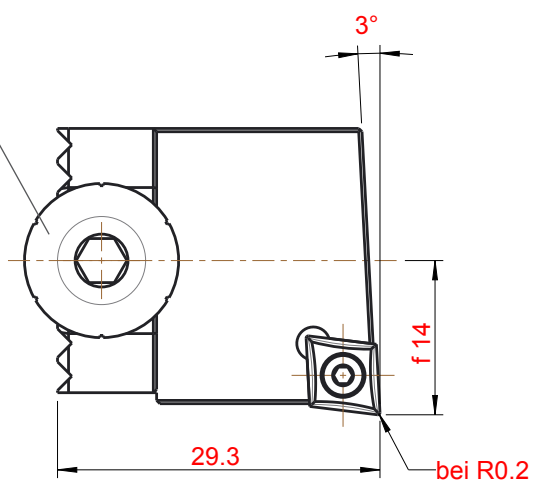

L
linksschneidend
cutting left

L.50.IK

Bestell-Nr/Order-Number **12-1154**

Anwendungsbereich **Langdrehen**
Application **turning**

Höhenverstellungsschraube
screw to adjust the height

002.00.69

Kühlmittelanschluss
Coolant supply

004.00.19



R
rechtsschneidend
cutting right

R.50.IK

Bestell-Nr/Order-Number **12-1153**

Wendeplatte
indexable insert

CC.. 06 02..

Senkschraube
counter sunk-head screw

001.01.01

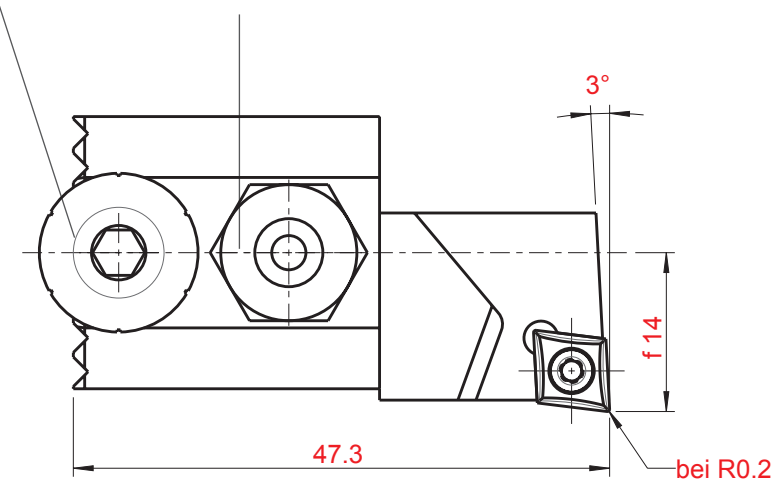

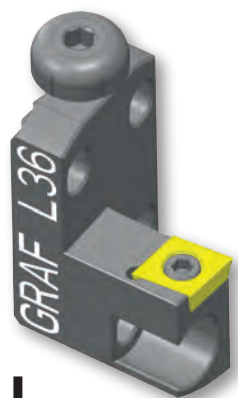

L
linksschneidend
cutting left

L.36

Bestell-Nr/Order-Number **12-0407**

Anwendungsbereich **Langdrehen**
Application **turning**

Höhenverstellungsschraube
screw to adjust the height

002.00.69

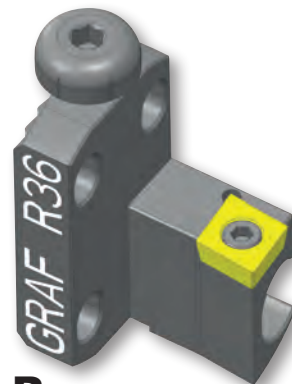

R
rechtsschneidend
cutting right

R.36

Bestell-Nr/Order-Number **12-0359**

Wendeplatte
indexable insert

CC.. 09 T3..

Senkschraube
counter sunk-head screw

001.01.13

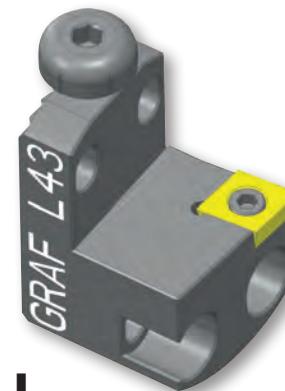
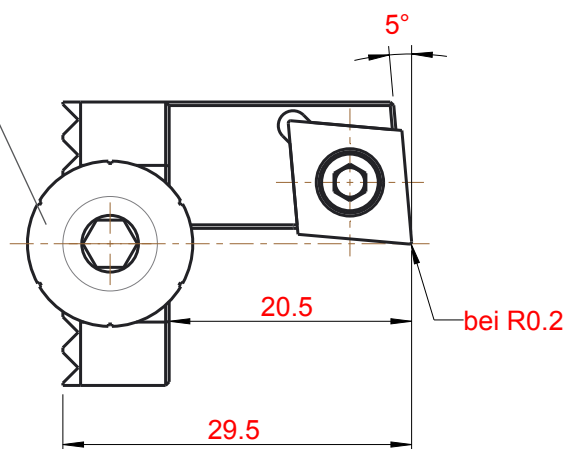

L
linksschneidend
cutting left

L.43

Bestell-Nr/Order-Number **12-0465**

Anwendungsbereich **Langdrehen**
Application **turning**

Höhenverstellungsschraube
screw to adjust the height

002.00.69

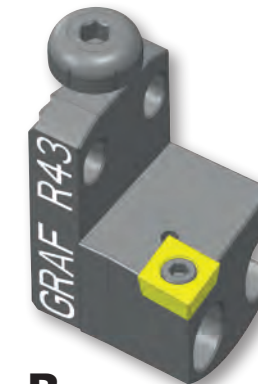

R
rechtsschneidend
cutting right

R.43

Bestell-Nr/Order-Number **12-0453**

Wendeplatte
indexable insert

CC.. 09 T3..

Senkschraube
counter sunk-head screw

001.01.13

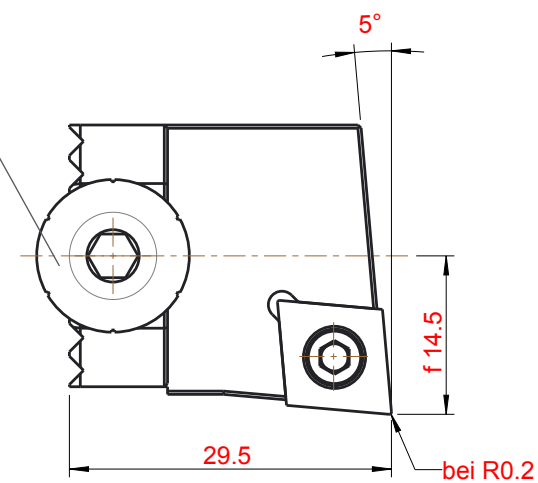



L
linksschneidend
cutting left

L.43.IK

Bestell-Nr/Order-Number **12-0503**

Anwendungsbereich **Langdrehen**
Application **turning**

Höhenverstellungsschraube screw to adjust the height	Kühlmittelsanschluss Coolant supply	Wendeplatte indexable insert	Senkschraube counter sunk-head screw
002.00.69	004.00.19	CC.. 09 T3..	001.01.13

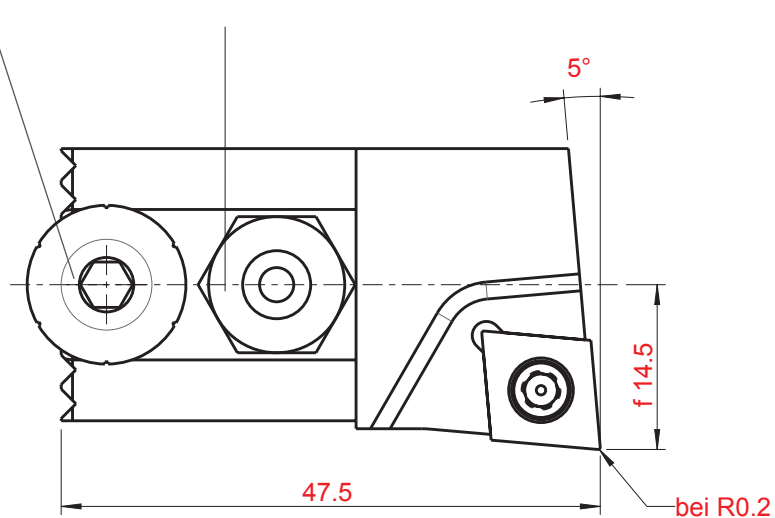

R
rechtsschneidend
cutting right

R.43.IK

Bestell-Nr/Order-Number **12-0490**



L
linksschneidend
cutting left

L.190

Bestell-Nr/Order-Number **12-1285**

Anwendungsbereich **Langdrehen**
Application **turning**

Höhenverstellungsschraube screw to adjust the height	Wendeplatte indexable insert	Spannelement clamping element	Gewindestift set screw	Unterlegplatte base plate
002.00.69	CN.. 12 04..	001.01.597	001.01.599	001.01.598

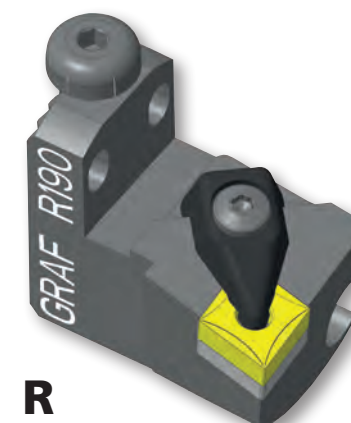
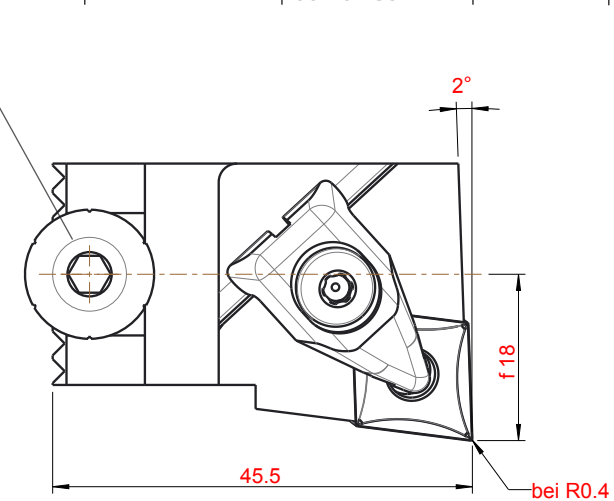

R
rechtsschneidend
cutting right

R.190

Bestell-Nr/Order-Number **12-1284**



L
linksschneidend
cutting left



R
rechtsschneidend
cutting right

L.54.IK

Bestell-Nr/Order-Number **12-1314**

Anwendungsbereich **Langdrehen**
Application **turning**

Höhenverstellungsschraube screw to adjust the height	Kühlmittelananschluss Coolant supply	Wendeplatte indexable insert	Spannelement clamping element	Gewindestift set screw
002.00.69	004.00.19	WN.. 06 04..	001.01.600	001.01.599

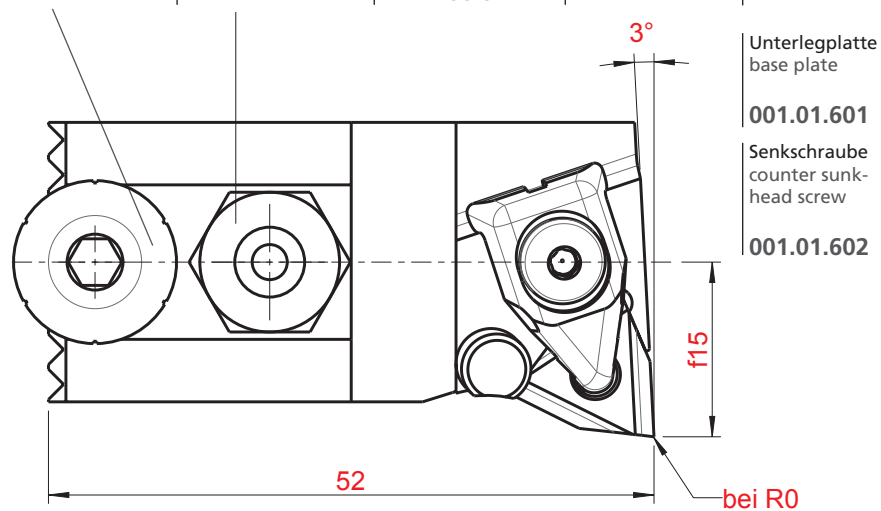

L
linksschneidend
cutting left



R
rechtsschneidend
cutting right

L.04

Bestell-Nr/Order-Number **12-0029**

Anwendungsbereich **Axialdrehen**
Application **face grooving**

Höhenverstellungsschraube screw to adjust the height	Wendeplatte indexable insert	Senkschraube counter sunk-head screw
002.00.69	SC.. 06 02..	001.01.01

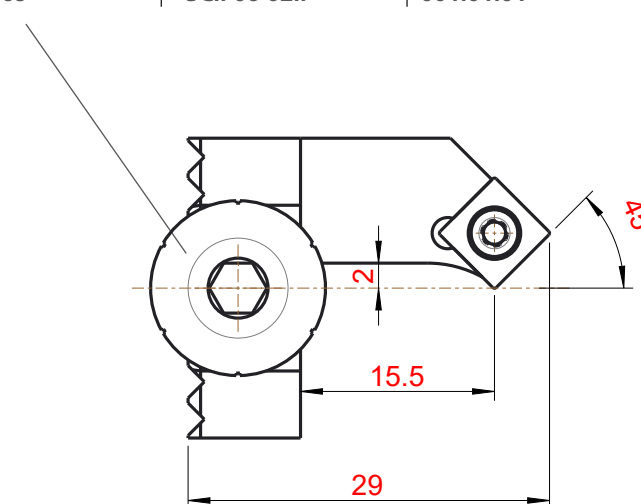



L
linksschneidend
cutting left

L.39

Bestell-Nr/Order-Number **12-0479**

Anwendungsbereich **Langdrehen**
Application **turning**

Höhenverstellungsschraube
screw to adjust the height

002.00.69

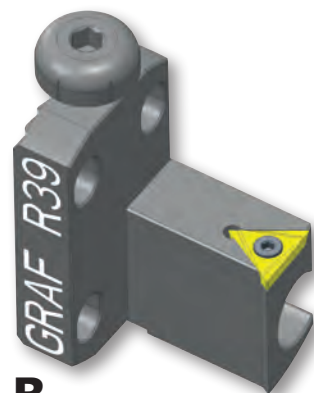

R
rechtsschneidend
cutting right

R.39

Bestell-Nr/Order-Number **12-0451**

Wendeplatte
indexable insert

TC.. 11 02..

Senkschraube
counter sunk-head screw

001.01.01

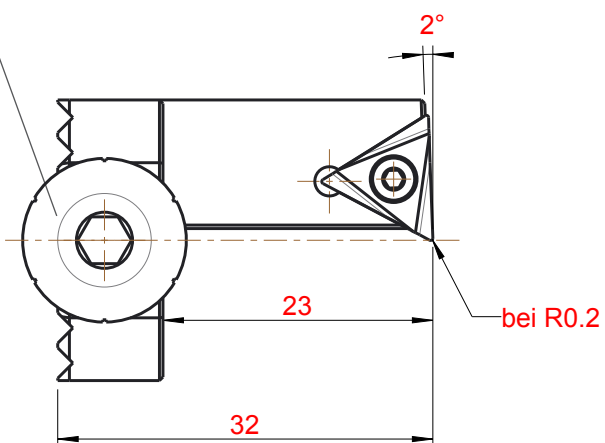

L
linksschneidend
cutting left

L.85

Bestell-Nr/Order-Number **12-0075**

Anwendungsbereich **Langdrehen**
Application **turning**

Höhenverstellungsschraube
screw to adjust the height

002.00.69



R
rechtsschneidend
cutting right

R.85

Bestell-Nr/Order-Number **12-0073**

Wendeplatte
indexable insert

TC.. 11 03..

Senkschraube
counter sunk-head screw

001.01.01

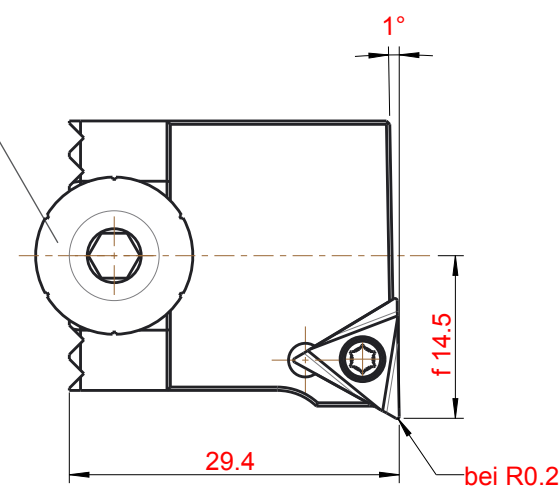

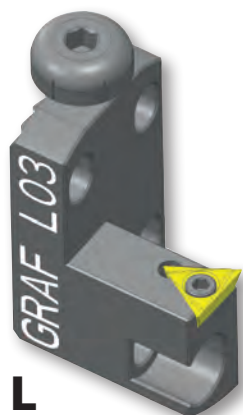

L
linksschneidend
cutting left

L.03

Bestell-Nr/Order-Number **12-0027**

Anwendungsbereich **Langdrehen**
Application **turning**

Höhenverstellungsschraube
screw to adjust the height

002.00.69

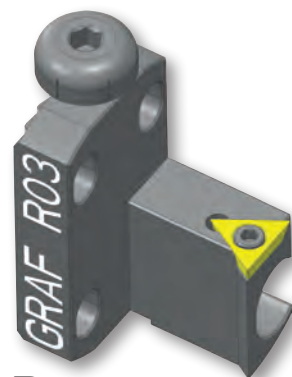

R
rechtsschneidend
cutting right

R.03

Bestell-Nr/Order-Number **12-0026**

Wendeplatte
indexable insert

TP.. 11 03..

Senkschraube
counter sunk-head screw

001.01.07

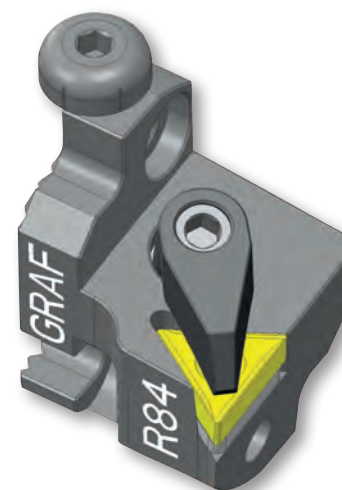
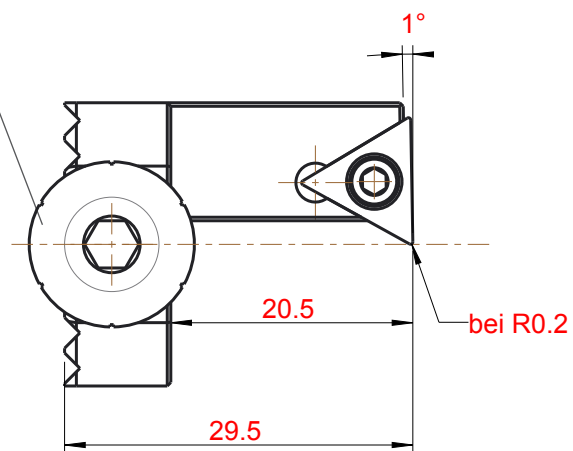

R.84

Bestell-Nr/Order-Number **12-0074**

Anwendungsbereich **Langdrehen**
Application **turning**

Höhenverstellungsschraube
screw to adjust the height

002.00.69

Wendeplatte
indexable insert

TN.. 16 04..

Spannelement
clamping element

001.01.41

Gewindestift
set screw

001.01.42

Unterlegplatte
base plate

001.01.43

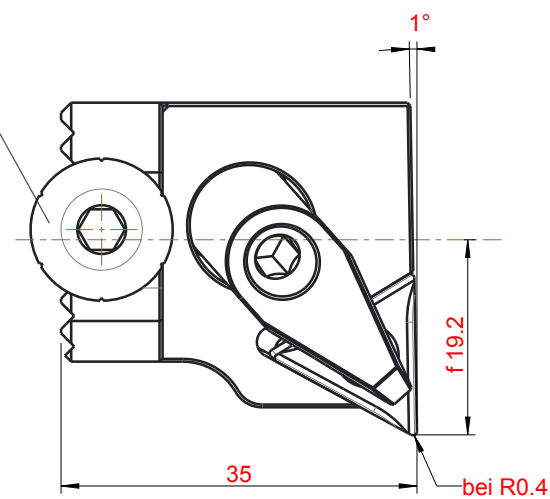



L
linksschneidend
cutting left

L.77

Bestell-Nr/Order-Number **12-0070**

Anwendungsbereich **Gewindedrehen**
Range of application **threading**

Höhenverstellungsschraube
screw to adjust the height

002.00.69

Wendeplatte
indexable insert

ER 16.. /EL 16..

Senkschraube
counter sunk-head screw

001.01.65

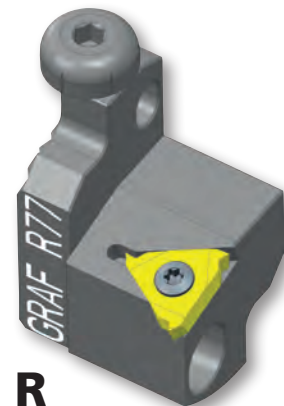
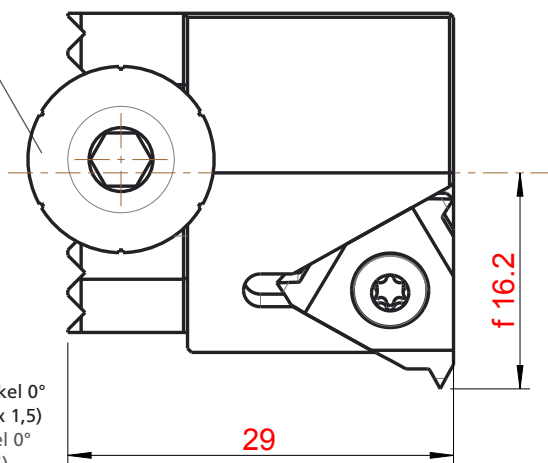

R
rechtsschneidend
cutting right

R.77

Bestell-Nr/Order-Number **12-0071**

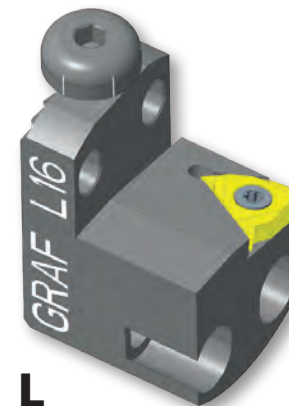

L
linksschneidend
cutting left

L.16

Bestell-Nr/Order-Number **12-0046**

Anwendungsbereich **Gewindedrehen**
Application **threading**

Höhenverstellungsschraube
screw to adjust the height

002.00.69

Wendeplatte
indexable insert

ER 16.. /EL 16..

Senkschraube
counter sunk-head screw

001.01.65

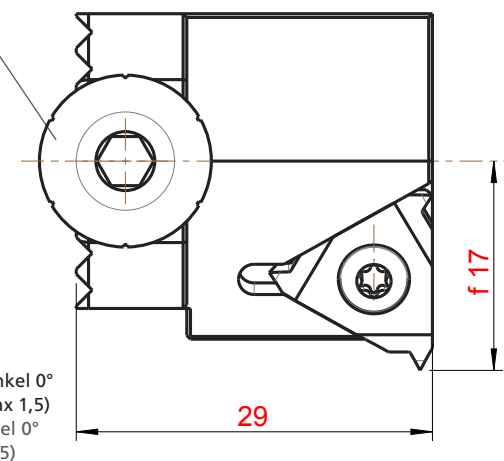

R
rechtsschneidend
cutting right

R.16

Bestell-Nr/Order-Number **12-0045**



L
linksschneidend
cutting left

L.16.IK

Bestell-Nr/Order-Number **12-0148**

Anwendungsbereich **Gewindedrehen**
Application **threading**

Höhenverstellungsschraube
screw to adjust the height

002.00.69

Kühlmittelanschluss
Coolant supply

004.00.19

Wendeplatte
indexable insert

ER 16.. /EL 16..

Senkschraube
counter sunk-head screw

001.01.65



R
rechtsschneidend
cutting right

R.16.IK

Bestell-Nr/Order-Number **12-0147**



L
linksschneidend
cutting left

L.123

Bestell-Nr/Order-Number **12-1147**

Anwendungsbereich **Gewindedrehen**
Range of application **threading**

Höhenverstellungsschraube
screw to adjust the height

002.00.69

Wendeplatte
indexable insert

ER 16.. /EL 16..



R
rechtsschneidend
cutting right

R.123

Bestell-Nr/Order-Number **12-1146**

Senkschraube
counter sunk-head screw

001.01.65

Zylinderschraube
screw

001.00.75

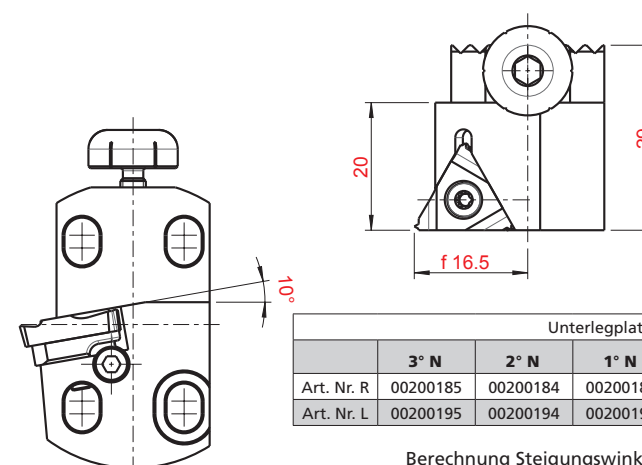
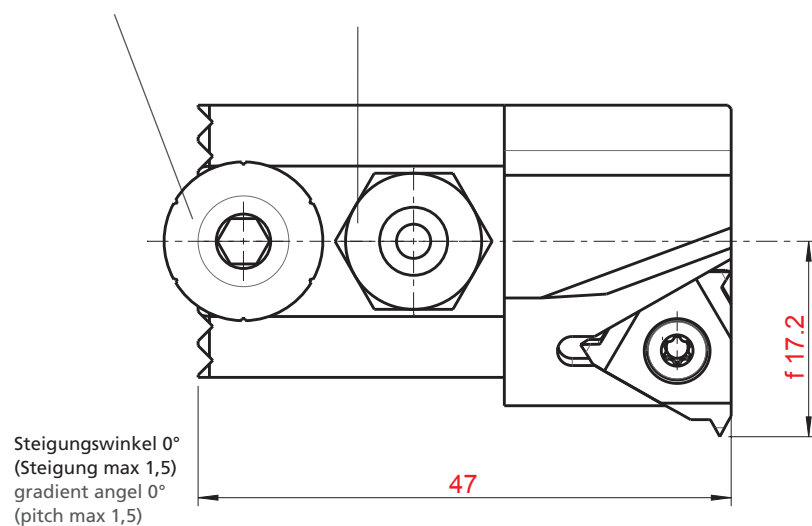

Unterlegplatte / Shim						
	3° N	2° N	1° N	0°	1° P	2° P
Art. Nr. R	00200185	00200184	00200183	00200180	00200182	00200181
Art. Nr. L	00200195	00200194	00200193	00200190	00200192	00200191

Berechnung Steigungswinkel auf Seite 4.82 - 4.83
calculation gradient angle see page 4.82 - 4.83



L
linksschneidend
cutting left

L.123.IK

Bestell-Nr/Order-Number **12-1326**

Anwendungsbereich **Gewindedrehen**
Range of application **threading**



R
rechtsschneidend
cutting right

R.123.IK

Bestell-Nr/Order-Number **12-1325**

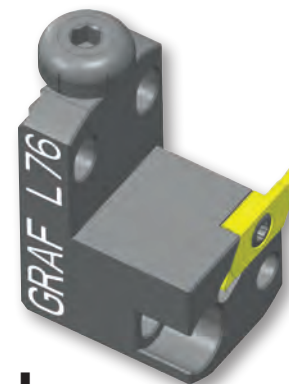

L
linksschneidend
cutting left

L.76

Bestell-Nr/Order-Number **12-1104**

Anwendungsbereich **Formstechen, Gewindestrehlen, Einstech-Langdrehen**
Application **forming, grooving, turning, threading**

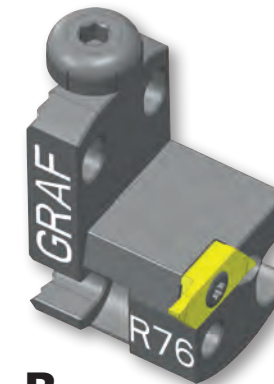

R
rechtsschneidend
cutting right

R.76

Bestell-Nr/Order-Number **12-0096**

3

Höhenverstellungsschraube screw to adjust the height	Kühlmittelanschluss Coolant supply	Wendeplatte indexable insert	Senkschraube counter sunk-head screw
002.00.69	004.00.19	ER 16.. /EL 16..	001.01.65

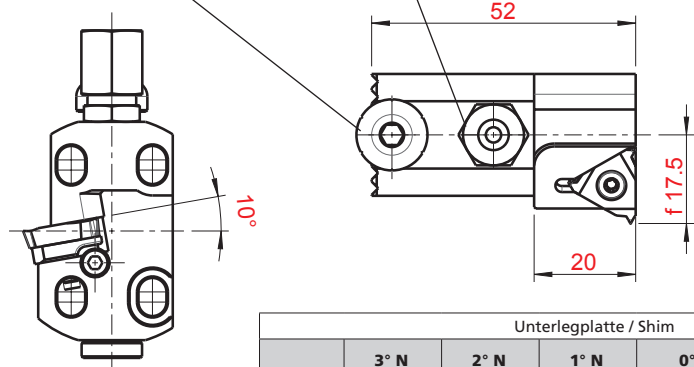

Zylinderschraube
screw
001.00.75

Unterlegplatte / Shim						
	3° N	2° N	1° N	0°	1° P	2° P
Art. Nr. R	00200185	00200184	00200183	00200180	00200182	00200181
Art. Nr. L	00200195	00200194	00200193	00200190	00200192	00200191

Berechnung Steigungswinkel auf Seite 4.82 - 4.83
calculation gradient angle see page 4.82 - 4.83

3

Höhenverstellungsschraube screw to adjust the height	Wendeplatte indexable insert	Senkschraube counter sunk-head screw
002.00.69	Horn Typ S274..	001.01.39

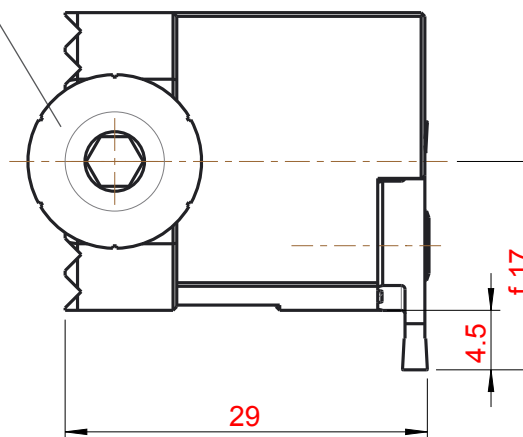



L
linksschneidend
cutting left

L.199

Bestell-Nr/Order-Number **12-1317**

Anwendungsbereich **Formstechen, Gewindestrehlen, Einstech-Langdrehen**
Application **forming, grooving, turning, threading**

Höhenverstellungsschraube
screw to adjust the height

002.00.69

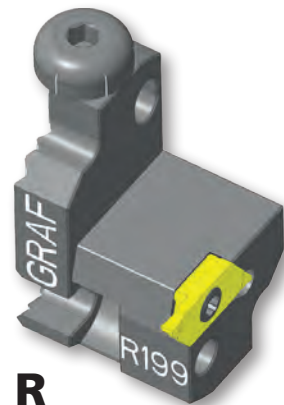

R
rechtsschneidend
cutting right

R.199

Bestell-Nr/Order-Number **12-1316**

Wendeplatte
indexable insert

Horn Typ S274..

Senkschraube
counter sunk-head screw

001.01.39

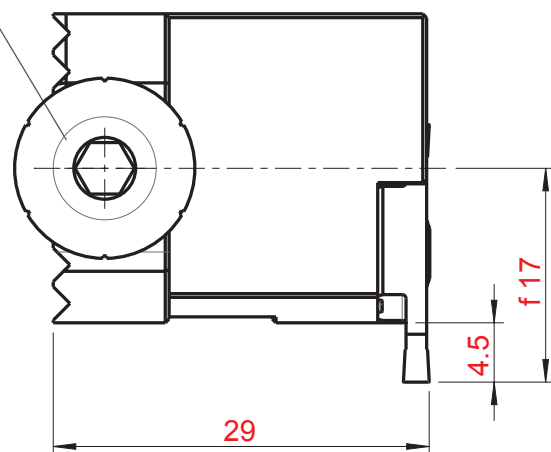

L
linksschneidend
cutting left

L.76.IK

Bestell-Nr/Order-Number **12-1075**

Anwendungsbereich **Formstechen, Gewindestrehlen, Einstech-Langdrehen**
Application **forming, grooving, turning, threading**

Höhenverstellungsschraube
screw to adjust the height

002.00.69

Kühlmittelanschluss
Coolant supply

004.00.19



R
rechtsschneidend
cutting right

R.76.IK

Bestell-Nr/Order-Number **12-0072**

Wendeplatte
indexable insert

Horn Typ S274..

Senkschraube
counter sunk-head screw

001.01.39

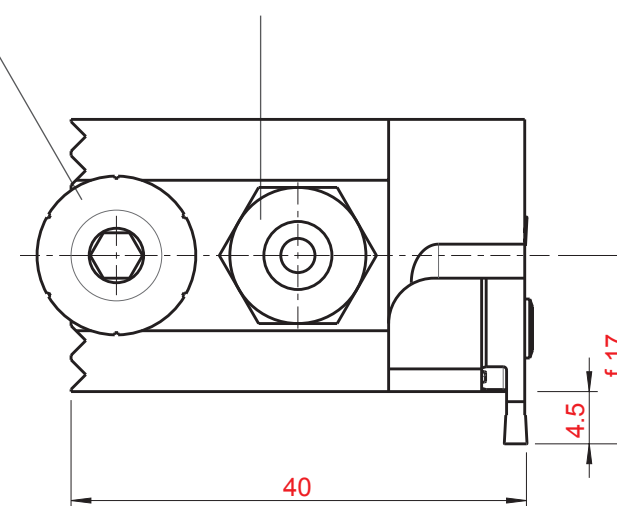



L
linksschneidend
cutting left

L.199.IK

Bestell-Nr/Order-Number **12-1390**

Anwendungsbereich **Formstechen, Gewindestrehlen, Einstech-Langdrehen**
Application **forming, grooving, turning, threading**

Höhenverstellungsschraube screw to adjust the height	Kühlmittelanschluss Coolant supply	Wendeplatte indexable insert	Senkschraube counter sunk-head screw
002.00.69	004.00.19	Horn Typ S274..	001.01.39

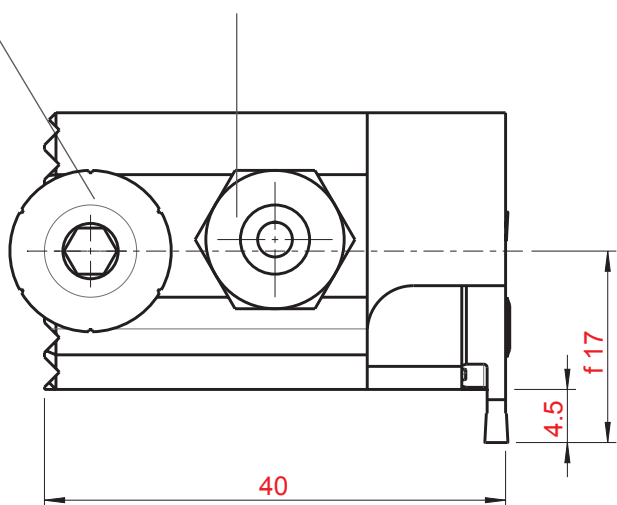

R
rechtsschneidend
cutting right

R.199.IK

Bestell-Nr/Order-Number **12-1389**



L
linksschneidend
cutting left

L.49

Bestell-Nr/Order-Number **12-1158**

Anwendungsbereich **Gewindedrehen**
Application **threading**

Höhenverstellungsschraube screw to adjust the height	Wendeplatte indexable insert	Senkschraube counter sunk-head screw
002.00.69	QER-12.. (Quad-Cut)	001.01.07

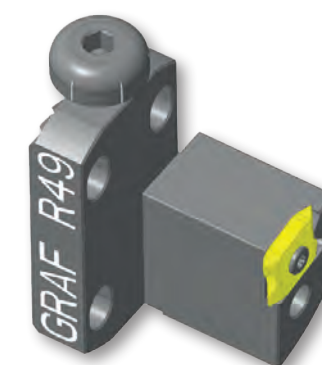
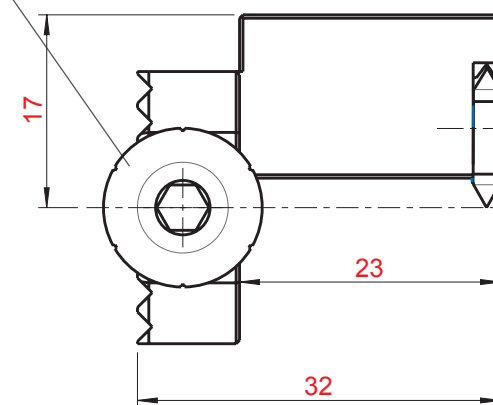

R
rechtsschneidend
cutting right

R.49

Bestell-Nr/Order-Number **12-0468**

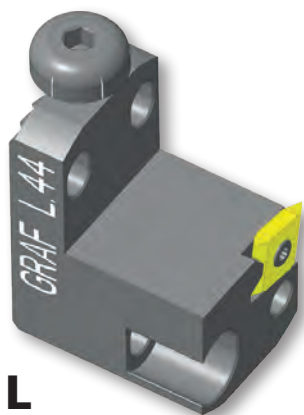

L
linksschneidend
cutting left

L.44

Bestell-Nr/Order-Number **12-0512**

Anwendungsbereich **Gewindedrehen**
Application **threading**

Höhenverstellungsschraube
screw to adjust the height

002.00.69

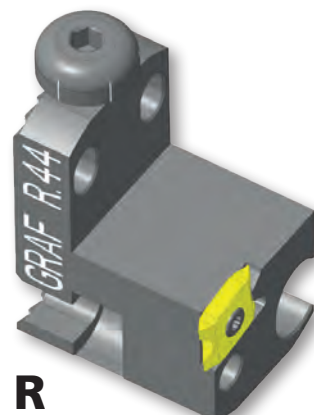

R
rechtsschneidend
cutting right

R.44

Bestell-Nr/Order-Number **12-0454**

Wendeplatte
indexable insert

QER-12.. (Quad-
Cut)

Senkschraube
counter sunk-head screw

001.01.07

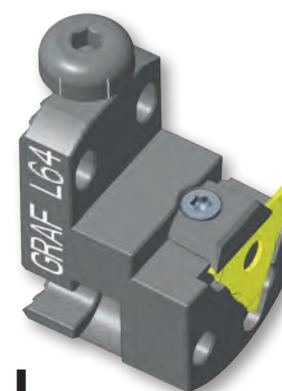
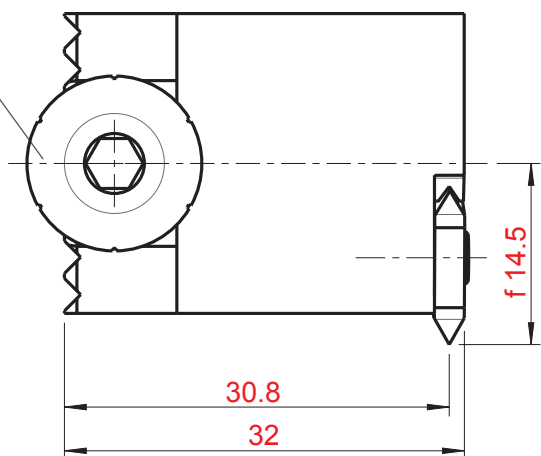

L
linksschneidend
cutting left

L.64

Bestell-Nr/Order-Number **12-0496**

Anwendungsbereich **Formstechen, Gewindestrehlen, Einstech-Langdrehen**
Application **forming, grooving, turning, threading**

Höhenverstellungsschraube
screw to adjust the height

002.00.69

Wendeplatte
indexable insert

Horn Typ 312..

Spannelement
clamping element

4.078

für Breite 0,5 bis 1,9
for width 0,5 - 1,9

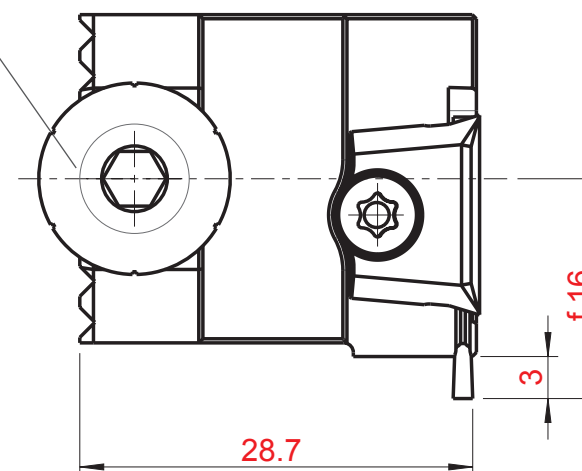



L
linksschneidend
cutting left

L.64.IK

Bestell-Nr/Order-Number **12-0504**



R
rechtsschneidend
cutting right

R.64.IK

Bestell-Nr/Order-Number **12-0501**

Anwendungsbereich **Formstechen, Gewindestrehlen, Einstech-Langdrehen**
Application **forming, grooving, turning, threading**

Höhenverstellungsschraube screw to adjust the height	Kühlmittelananschluss Coolant supply	Wendepatte indexable insert	Spannelement clamping element
002.00.69	004.00.19	Horn Typ 312..	4.081 (R) / 4.082 (L)

für Breite 0,5 bis 1,9
for width 0,5 - 1,9

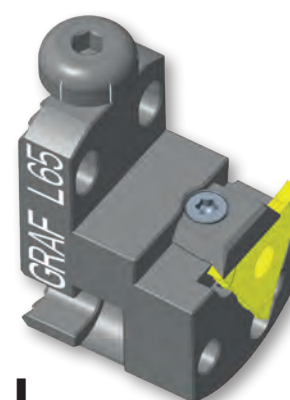
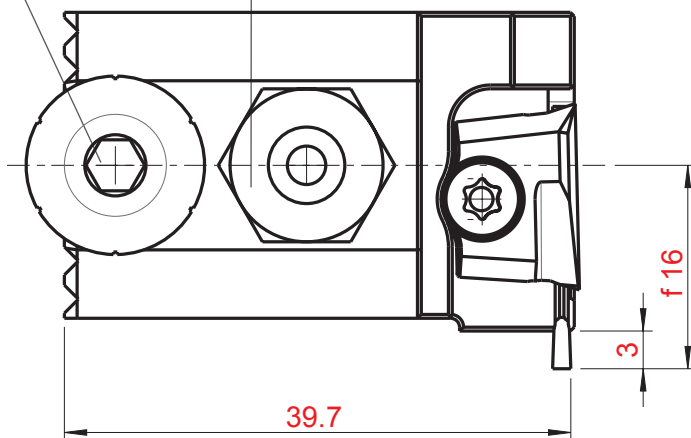

L
linksschneidend
cutting left

L.65

Bestell-Nr/Order-Number **12-0497**

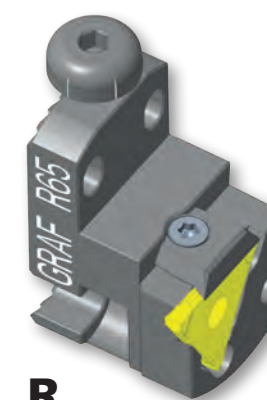

R
rechtsschneidend
cutting right

R.65

Bestell-Nr/Order-Number **12-0487**

Anwendungsbereich **Formstechen, Gewindestrehlen, Einstech-Langdrehen**
Application **forming, grooving, turning, threading**

Höhenverstellungsschraube screw to adjust the height	Wendepatte indexable insert	Spannelement clamping element	für Breite 1,9 bis 2,9 for width 1,9 - 2,9
002.00.69	Horn Typ 312..	4.078	

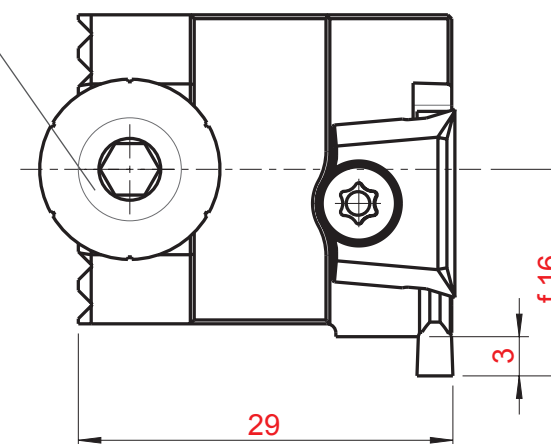



L
linksschneidend
cutting left

L.65.IK

Bestell-Nr/Order-Number **12-0505**



R
rechtsschneidend
cutting right

R.65.IK

Bestell-Nr/Order-Number **12-0502**

Anwendungsbereich **Formstechen, Gewindestrehlen, Einstech-Langdrehen**
Application **forming, grooving, turning, threading**

Höhenverstellungsschraube screw to adjust the height	Kühlmittelananschluss Coolant supply	Wendepatte indexable insert	Spannelement clamping element
002.00.69	004.00.19	Horn Typ 312..	4.081 (R) / 4.082 (L)

für Breite 1,9 bis 2,9
for width 1,9 - 2,9

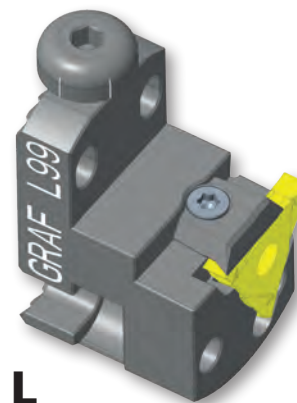
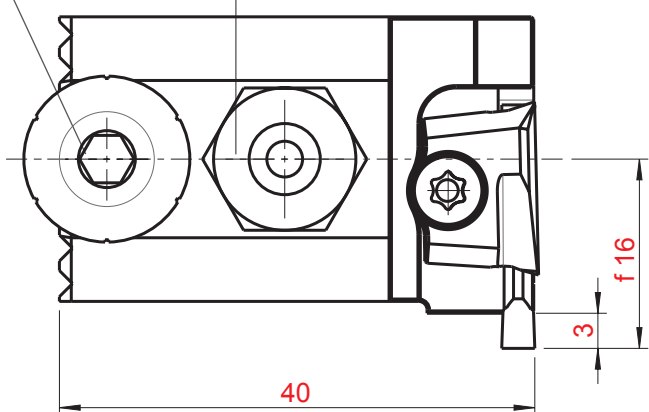

L
linksschneidend
cutting left

L.99

Bestell-Nr/Order-Number **12-1048**

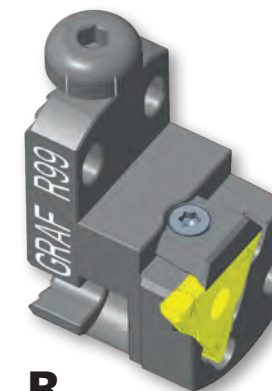

R
rechtsschneidend
cutting right

R.99

Bestell-Nr/Order-Number **12-0547**

Anwendungsbereich **Formstechen, Gewindestrehlen, Einstech-Langdrehen**
Application **forming, grooving, turning, threading**

Höhenverstellungsschraube screw to adjust the height	Wendepatte indexable insert	Spannelement clamping element	für Breite 2,9 bis 3,9 for width 2,9 - 3,9
002.00.69	Horn Typ 312..	4.078	

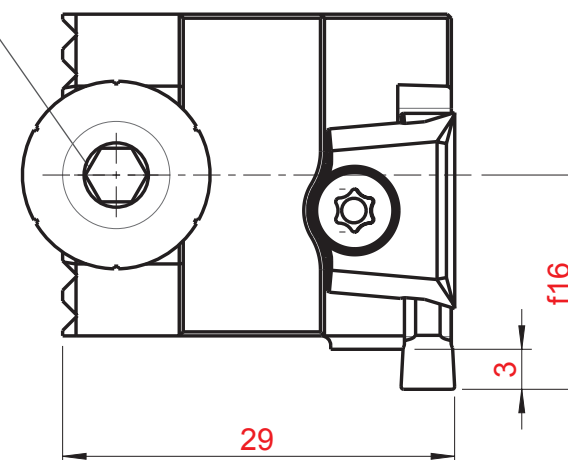

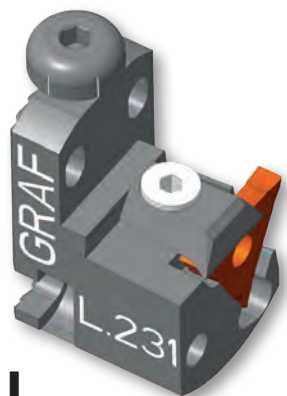

L
linksschneidend
cutting left

L.231

Bestell-Nr/Order-Number **12-1403**

Anwendungsbereich **Formstechen, Gewindestrehlen, Einstech-Langdrehen**
Application **forming, grooving, turning, threading**

Höhenverstellungsschraube
screw to adjust the height

002.00.69

Wendepatte
indexable insert

Horn Typ 312..

Spannelement
clamping element

4.344

für Breite 3,9 bis 4,9
for width 3,9 - 4,9

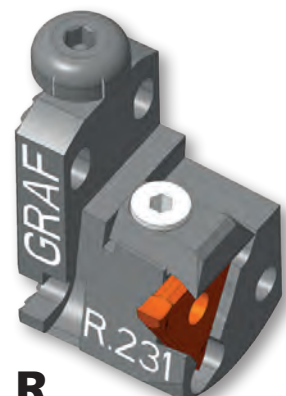
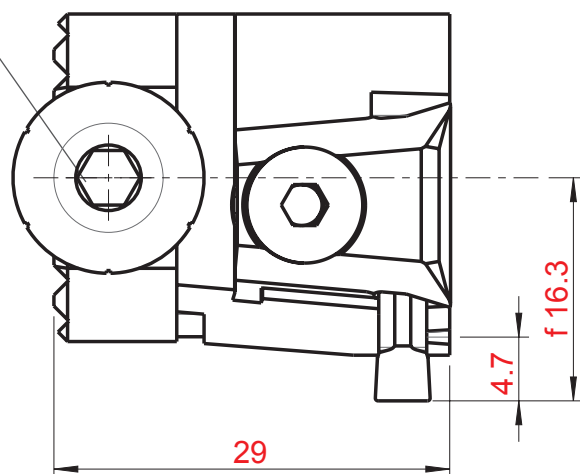

R
rechtsschneidend
cutting right

R.231

Bestell-Nr/Order-Number **12-1402**

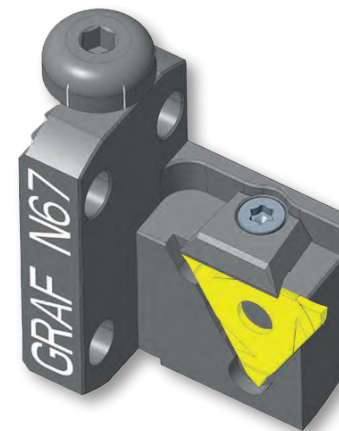

N.67

Bestell-Nr/Order-Number **12-1061**

Anwendungsbereich **Formstechen, Einstech-Langdrehen**
Application **forming, turning**

Höhenverstellungsschraube
screw to adjust the height

002.00.69

Wendepatte
indexable insert

Horn Typ 312..

Spannelement
clamping element

4.078

für Breite 0,5 bis 1,9
for width 0,5 - 1,9

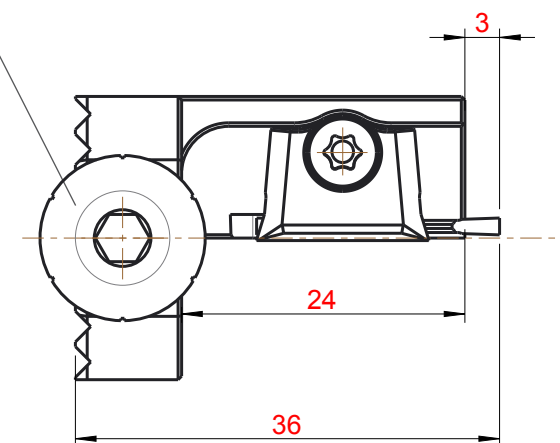



N.68

Bestell-Nr/Order-Number **12-0498**

Anwendungsbereich **Formstechen, Gewindestrehlen, Einstech-Langdrehen**
Application **forming, grooving, turning**

Höhenverstellungsschraube screw to adjust the height	Wendeplatte indexable insert	Spannelement clamping element	für Breite 1,9 bis 2,9 for width 1,9 - 2,9
002.00.69	Horn Typ 312..	4.078	

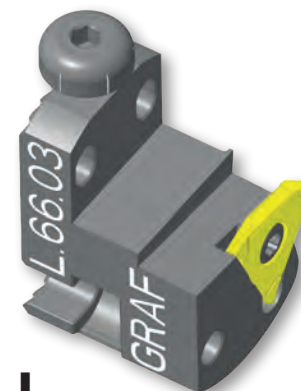
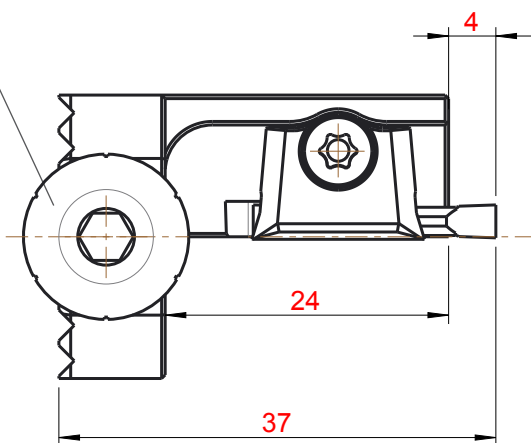

L

linksschneidend
cutting left

L.66.03

Bestell-Nr/Order-Number **12-1436**

Anwendungsbereich **Formstechen, Gewindestrehlen, Einstech-Langdrehen**
Application **forming, grooving, turning, threading**

Höhenverstellungsschraube screw to adjust the height	Wendeplatte indexable insert	Senkschraube counter sunk-head screw	für Breite 03 for width 03
002.00.69	Horn Typ 315..	001.01.70	

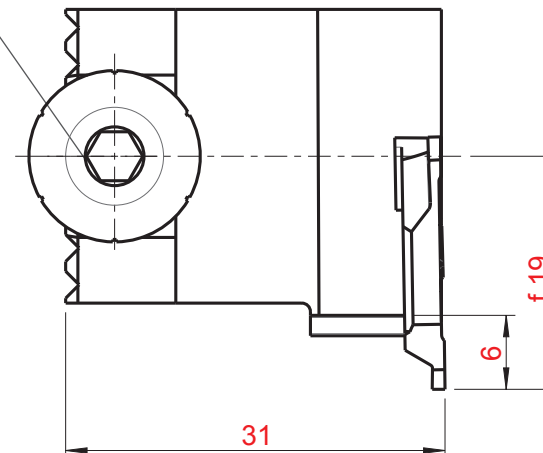

R

rechtsschneidend
cutting right

R.66.03

Bestell-Nr/Order-Number **12-1435**

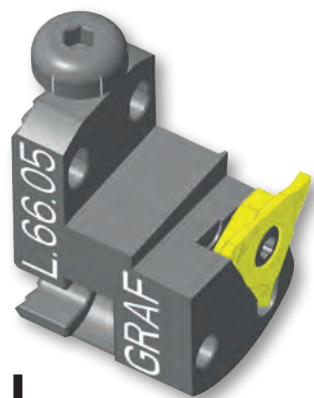

L
linksschneidend
cutting left

L.66.05

Bestell-Nr/Order-Number **12-1438**

Anwendungsbereich **Formstechen, Gewindestrehlen, Einstech-Langdrehen**
Application **forming, grooving, turning, threading**

Höhenverstellungsschraube
screw to adjust the height

002.00.69

Wendeplatte
indexable insert

Horn Typ 315..

Senkschraube
counter sunk-head
screw

001.01.70

für Breite 05
for width 05

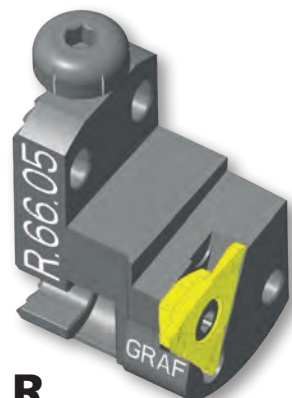
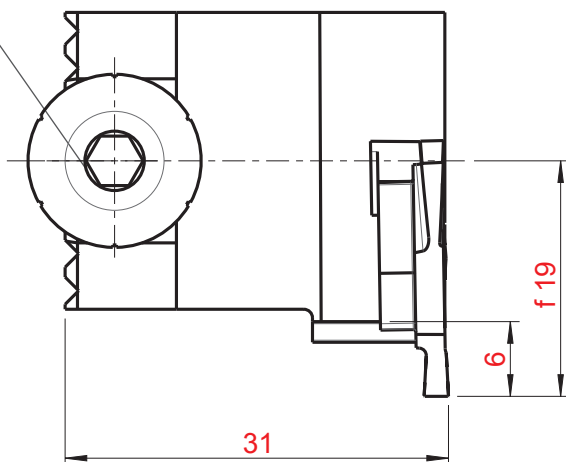

R
rechtsschneidend
cutting right

R.66.05

Bestell-Nr/Order-Number **12-1437**



L
linksschneidend
cutting left

L.45

Bestell-Nr/Order-Number **12-1433**

Anwendungsbereich **Formstechen, Gewindestrehlen, Einstech-Langdrehen**
Range of application **profiling, threading, grooving**

Höhenverstellungsschraube
screw to adjust the height

002.00.69

Wendeplatte
indexable insert

Typ CS06..., SCD06..

Senkschraube
counter sunk-head screw

001.01.03

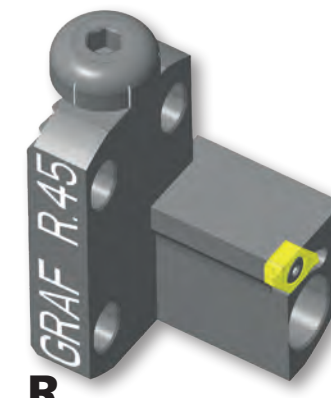
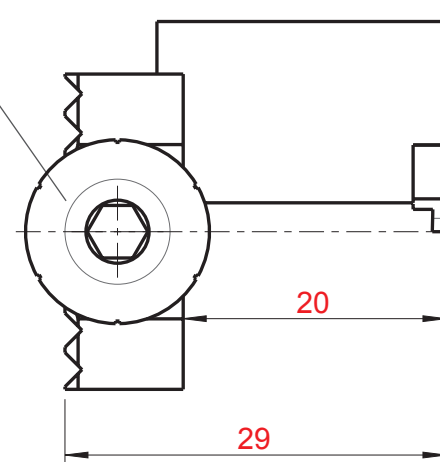

R
rechtsschneidend
cutting right

R.45

Bestell-Nr/Order-Number **12-1432**

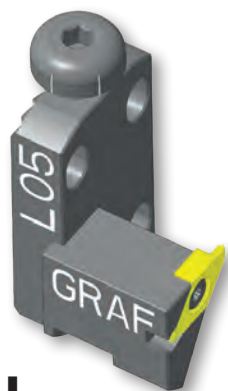

L
linksschneidend
cutting left

L.05

Bestell-Nr/Order-Number **12-0031**

Anwendungsbereich **Formstechen, Gewindestrehlen, Einstech-Langdrehen**
Range of application **profiling, threading, grooving**

Höhenverstellungsschraube
screw to adjust the height

002.00.69

Wendepatte
indexable insert

SCD 08.., CSX 08.., CS 08.., VP CS 08..,
TP CS 08..

Senkschraube
counter sunk-head screw

001.01.04

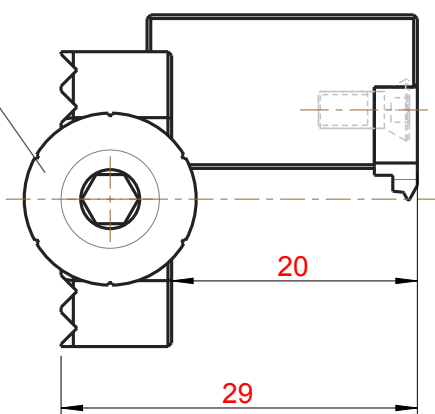

20

29

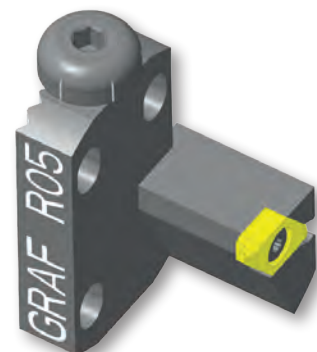

R
rechtsschneidend
cutting right

R.05

Bestell-Nr/Order-Number **12-0030**

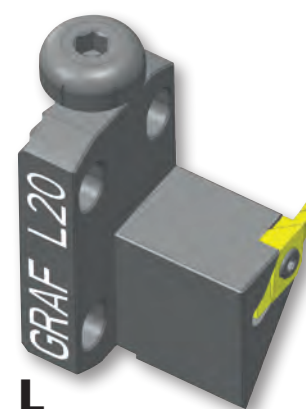

L
linksschneidend
cutting left

L.20

Bestell-Nr/Order-Number **12-0821**

Anwendungsbereich **Formstechen, Gewindestrehlen, Einstech-Langdrehen**
Application **forming, grooving, turning, threading**

Höhenverstellungsschraube
screw to adjust the height

002.00.69

Wendepatte
indexable insert

SCD 08.., CSX 08.., CS 08.., VP CS 08..,
TP CS 08..

Senkschraube
counter sunk-head screw

001.01.04

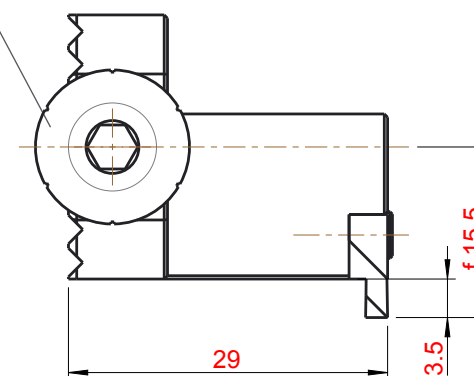

29

3.5

f 15.5

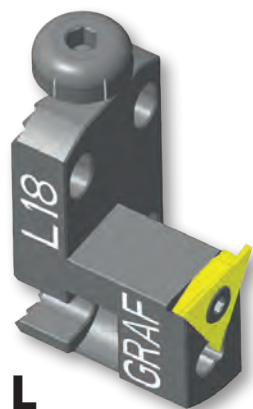

L
linksschneidend
cutting left

L.18

Bestell-Nr/Order-Number **12-0048**

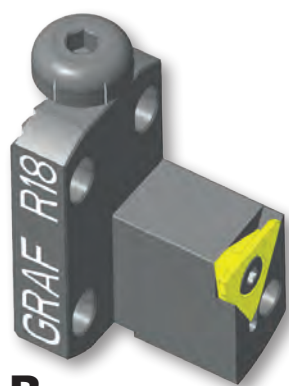

R
rechtsschneidend
cutting right

R.18

Bestell-Nr/Order-Number **12-0047**

Anwendungsbereich

Formstechen, Gewindestrehlen, Einstech-Langdrehen, Kopierdrehen
Range of application **profiling, threading, grooving, copy turning**

Höhenverstellungsschraube
screw to adjust the height

002.00.69

Wendeplatte
indexable insert

GTMH 32

Senkschraube
counter sunk-head screw

001.01.27

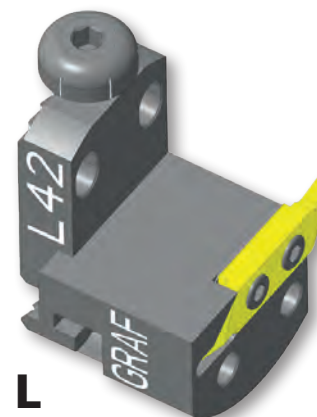
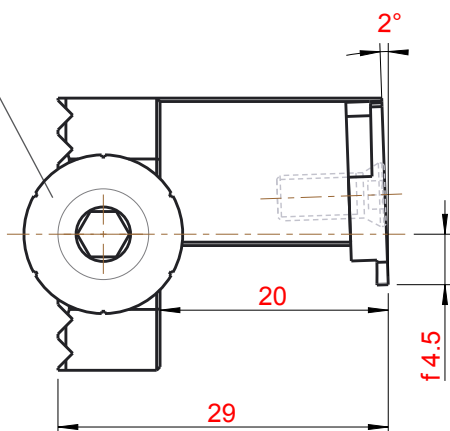

L
linksschneidend
cutting left

L.42

Bestell-Nr/Order-Number **12-0466**

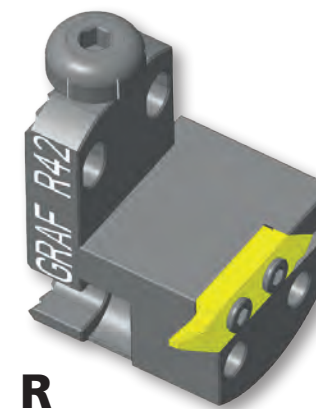

R
rechtsschneidend
cutting right

R.42

Bestell-Nr/Order-Number **12-0461**

Anwendungsbereich

Formstechen, Gewindestrehlen, Einstech-Langdrehen, Kopierdrehen
Range of application **profiling, threading, grooving, copy turning**

Höhenverstellungsschraube
screw to adjust the height

002.00.69

GRAF Wendeplatte
GRAF indexable insert

G 02.., G 03.., G 04.., TP G 05/VP G 05

Senkschraube
counter sunk-head screw

001.01.15

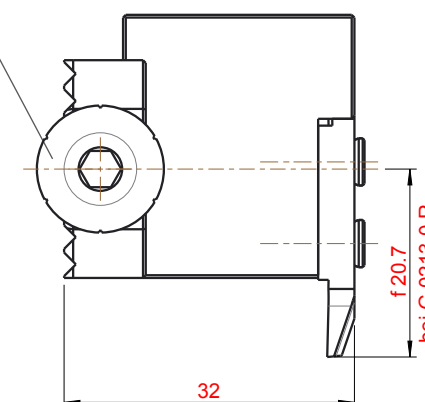

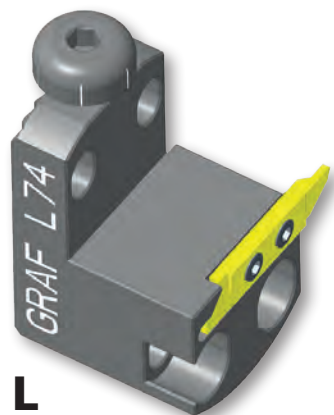

L
linksschneidend
cutting left

L.74

Bestell-Nr/Order-Number **12-0519**

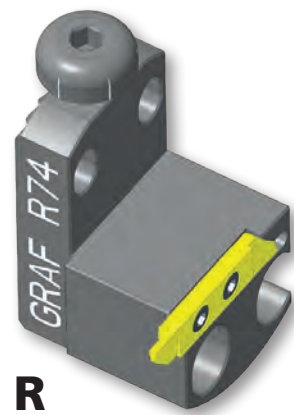

R
rechtsschneidend
cutting right

R.74

Bestell-Nr/Order-Number **12-0518**

Anwendungsbereich **Formstechen, Gewindestrehlen, Einstech-Langdrehen**
Range of application **profiling, threading, grooving**

Höhenverstellungsschraube
screw to adjust the height

002.00.69

Applitec Wendeplatte
Applitec indexable insert

Für L Applitec Serie 730
Für R Applitec Serie 740

Senkschraube
counter sunk-head screw

001.01.45

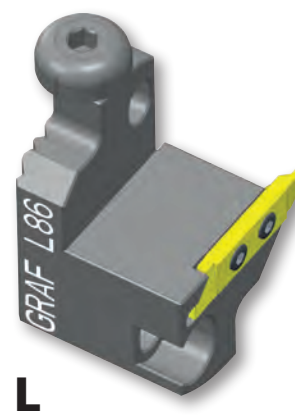
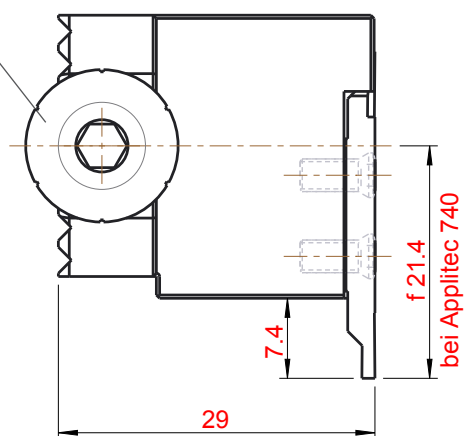

L
linksschneidend
cutting left

L.86

Bestell-Nr/Order-Number **12-0522**



R
rechtsschneidend
cutting right

R.86

Bestell-Nr/Order-Number **12-0521**

Anwendungsbereich **Formstechen, Gewindestrehlen, Einstech-Langdrehen**
Application **forming, grooving, turning, threading**

Höhenverstellungsschraube
screw to adjust the height

002.00.69

Applitec Wendeplatte
Applitec indexable insert

Für L Applitec Serie 730
Für R Applitec Serie 740

Senkschraube
counter sunk-head screw

001.01.45

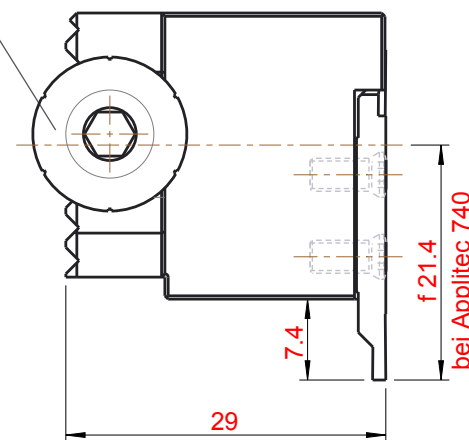

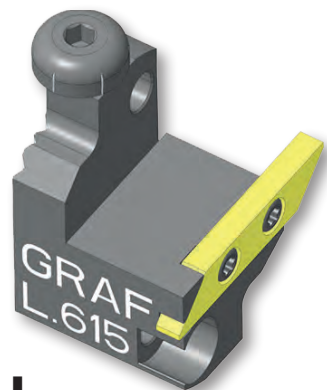

L
linksschneidend
cutting left

L.615

Bestell-Nr/Order-Number **12-1132**

Anwendungsbereich **Formstechen, Gewindestrehlen, Einstech-Langdrehen**
Application **forming, grooving, turning, threading**

Höhenverstellungsschraube
screw to adjust the height

002.00.69

Precitool Wendeplatte
precitool indexable insert

Typ 615

Senkschraube
counter sunk-head screw

628V

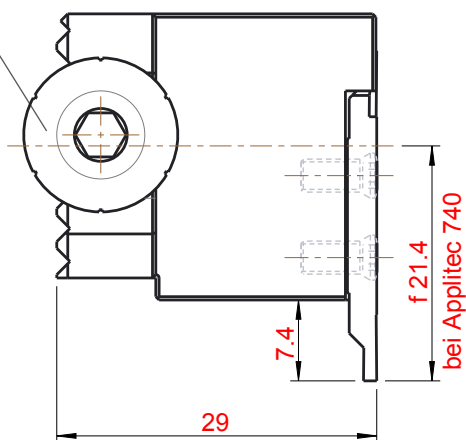

R
rechtsschneidend
cutting right

R.615

Bestell-Nr/Order-Number **12-1131**

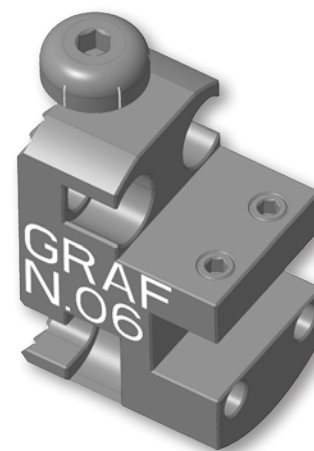

N.06

Anwendungsbereich **Rückseitenbearbeitung für Vierkantschaft**
Application **back working for square shank**

Höhenverstellungsschraube
screw to adjust the height

002.00.69

Gewindestift
set screw

002.00.11

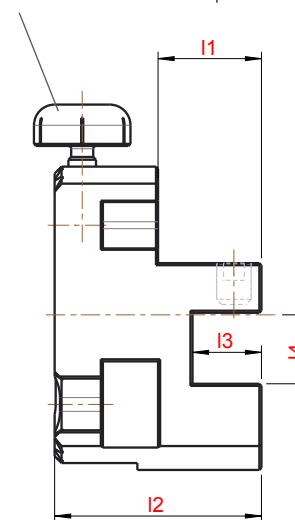

Bezeichnung Description	Bestell-Nr. Order-Number	I1	I2	I3	I4
N.06.10	12-0032	15	30	10	10
N.06.12	12-1080	15	30	12	12

**Höheneinstell-Vorrichtung
für Rückseitenbearbeitungs Drehhalter HVR 400**

Device for height adjusting
for back working holder HVR 400

	d1	d2	Bestell-Nr. Order-Number	Bezeichnung Description
STAR	16	22	12-0506	HVR.400.16.22
	20	22	12-1106	HVR.400.20.22
CITIZEN	3/4"	1"	12-0507	HVR.400.34.10
HANWHA	20	28	12-0523	HVR.400.20.28
	25	33	12-0511	HVR.400.25.23
	25	28	12-0548	HVR.400.25.28
	25	34	12-0546	HVR.400.25.34
MAIER	30	34	12-1218	HVR.400.30.34

weitere Abmessungen auf Anfrage
Please ask us for other dimensions

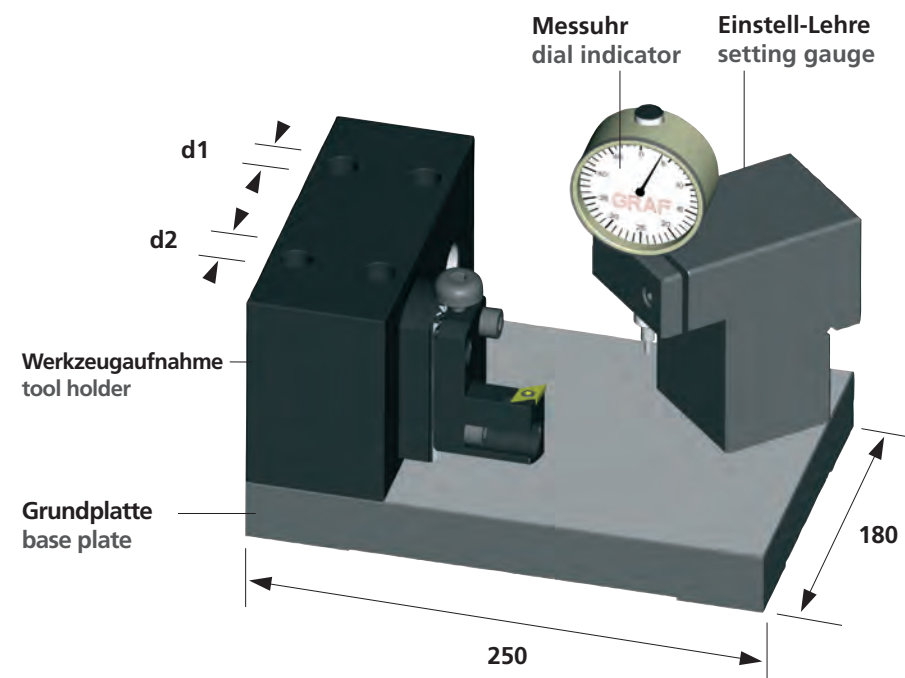

INHALTSVERZEICHNIS SUMMARY

GRAF Spannzangenhalter Typ GZ.65 mit Innenkühl-Anschluß vorne GRAF chuck holder type GZ.65 with coolant connection in front	4.3
GRAF Spannzangenhalter Typ GZ.66 mit Innenkühl-Anschluß hinten GRAF chuck holder type GZ.66 with coolant connection back	4.6
GRAF Klemmring für Rundschaftwerkzeuge GRAF clamping ring for round shank tools	4.10
GRAF Doppelspannzangenhalter Typ GZ.67 GRAF double chuck holder type GZ.67	4.12
GRAF Doppelspannzangenhalter Typ GZ.79 mit Innenkühl-Anschluß GRAF double chuck holder type GZ.79 with coolant connection	4.14
GRAF Spannmutter ER-M GRAF chucking nut ER-M	4.16
GRAF Spannzangen GRAF collet chuck	4.17
GRAF Mehrkant-Drückgerät zum Innendrücken GRAF multi-sided hitting equipment for interior pressing	4.18
GRAF Gewindeborehalter Typ GB.68 mit Längenausgleich GRAF square leaded tap holder type GB.68 with length compensation	4.22
GRAF Gewindegewindehalter Typ GS.69 mit Längenausgleich GRAF screw threading holder type GS.69 with length compensation	4.24
GRAF Pendelhalter Typ GP.70 für Reibahlen mit zylindrischem Schaft GRAF floating holder type GP.70 for reamers with cylindrical shaft	4.26
GRAF Bohrstangenhalter Typ BS.71 mit Kühlmittel-Anschluß GRAF boring bar holder type BS.71 with coolant connection	4.28
GRAF Bohrerhalter Typ BHE.72 mit Kühlmittel-Anschluß hinten GRAF drill holder type BHE.72 with coolant connection back	4.30
GRAF Bohrerhalter Typ BHE.73 mit Kühlmittel-Anschluß vorne GRAF drill holder type BHE.72 with coolant connection in front	4.33

INHALTSVERZEICHNIS
SUMMARY

GRAF Reduzierhülsen
GRAF adapter sleeve 4.36

GRAF Reduzierhülsen mit Innenkühlung
GRAF adapter sleeve with innercooling 4.38

GRAF Inndreh-Rundschafthalter Typ HORN IR.105 mit Innenkühlmittel-Anschluß hinten
GRAF boring-round shank tool type HORN IR.105 with coolant connection back 4.40

GRAF Inndreh-Rundschafthalter Typ HORN IR.105 mit Innenkühlmittel-Anschluß vorne
GRAF boring-round shank tool type HORN IR.105 with coolant connection in front 4.42

GRAF Inndreh-Rundschafthalter Typ Picco BS.75 mit Innenkühlmittel-Anschluß hinten
GRAF boring-round shank tool type Picco BS.75 with coolant connection back 4.44

GRAF Fräsdorne
GRAF milling arbors 4.46

GRAF Fräsweldon
GRAF milling weldon 4.64

GRAF Rundschaft-Wendeplattenhalter Ø 20
GRAF round shank turret plate holder Ø 20 4.69
Typ Platte / type insert DC.. / VC.. / 16ER / CC..

GRAF Rundschaft-Wendeplattenhalter Ø 25
GRAF round shank turret plate holder Ø 25 4.72
Typ Platte / type insert DC.. / VC.. / 16ER / CC.. / HORN 312

Berechnung Steigungswinkel
Calculation helix angle 4.82

Spannzangenhalter Typ GZ.65
mit Innenkühlanschluß vorne
chuck holder type GZ.65
with coolant connection in front

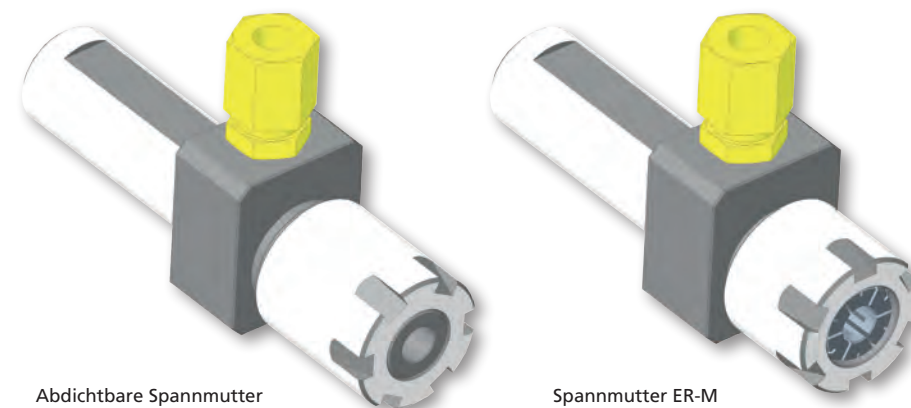

Abdichtbare Spannmutter
ER-MA muss separat bestellt
werden, siehe Seite 4.18!
sealed chucking nut ER-MA
must be ordered separately,
see page 4.18!

Spannmutter ER-M
ist inklusive!
chucking nut ER-M
is inclusive!

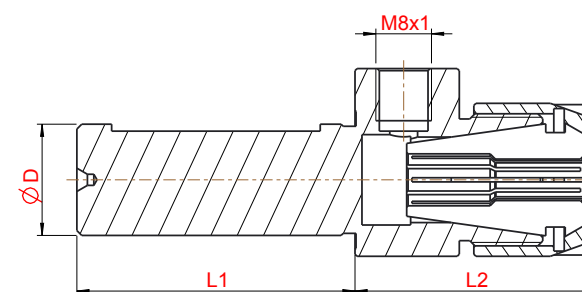

Beispiel:
mit Spannmutter ER-M
Example:
with chucking nut ER-M

Längendifferenz zwischen normaler und abdichtbarer Spannmutter in L2 length difference between normal and sealed chucking nut in L2	Zange chuck	L2 mit abgedichteter Zange L2 with sealed chucking nut
		ER 16
	ER 20	+ 7,5 mm
	ER 25	+ 7,5 mm

Bestell Nummer Order Number	Bezeichnung Description	Ø D	Zange Chuck	L1	L2
11-0379	GZ.65.1640.16	16	ER 16	40	35
11-1030	GZ.65.3440.11	3/4"	ER 11	40	33
11-0377	GZ.65.3440.16	3/4"	ER 16	40	35
11-0376	GZ.65.2040.16	20	ER 16	40	35
11-0490	GZ.65.2080.16	20	ER 16	80	35
11-0489	GZ.65.2240.16	22	ER 16	40	35
11-1024	GZ.65.2528.25	25	ER 25	28	40
11-1028	GZ.65.2528.20	25	ER 20	28	43
11-1275	GZ.65.2528.16	25	ER 16	28	40
11-1042	GZ.65.2560.25	25	ER 25	60	52
11-1276	GZ.65.2560.20	25	ER 20	60	48
11-1277	GZ.65.2560.16	25	ER 16	60	40
11-0474	GZ.65.10.100.16	1"	ER 16	60	40
11-0443	GZ.65.1080.20	1"	ER 20	80	45
11-0439	GZ.65.1080.25	1"	ER 25	80	48
11-0378	GZ.65.1060.16	1"	ER 16	100	40
11-0475	GZ.65.10100.20	1"	ER 20	100	48
11-0380	GZ.65.3260.20	32	ER 20	60	45
11-0416	GZ.65.3260.25	32	ER 25	60	48
11-0473	GZ.65.1621.16. SR16/20R	16	ER 16	21	40
11-0469	GZ.65.2230.16.SR32	22	ER 16	30	40
11-0486	GZ.65.2230.20.SR32	22	ER 20	30	50
11-0487	GZ.65.2230.25.SR32	22	ER 25	30	50

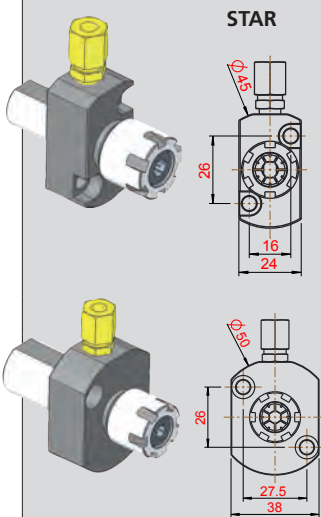

Bestell Nummer Order Number	Bezeichnung Description	Ø D	Zange Chuck	L1	L2
11-0803	GZ.65.2806.20	28	ER 20	6	50
11-0802	GZ.65.2806.25	28	ER 25	6	55
11-0688	GZ.65.4260.20	42	ER20	60	44
11-0506	GZ.65.3420.16	34	ER 16	20	42
11-0505	GZ.65.3420.20	34	ER 20	20	45
11-0508	GZ.65.3420.25	34	ER 25	20	50
11-0585	GZ.65.3444.25	34	ER25	44	82
11-0507	GZ.65.3425.16	34	ER16	25	34
11-0582	GZ.65.3425.20	34	ER20	25	36
11-0424	GZ.65.3425.25	34	ER25	25	38

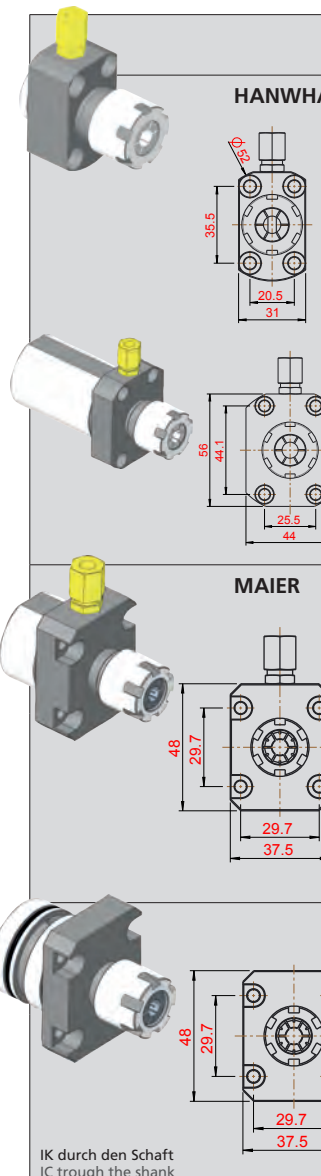

**Spannzangenhalter Typ GZ.66
mit Innenkühlanschluss hinten**
chuck holder type GZ.66
with coolant supply

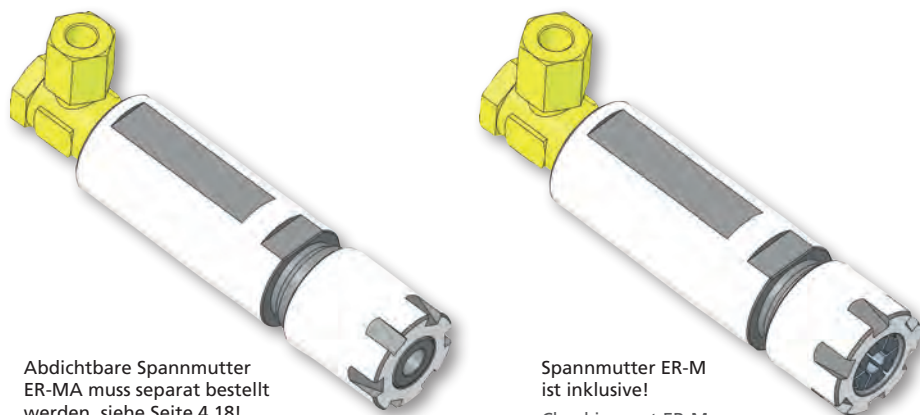

Abdichtbare Spannmutter ER-MA muss separat bestellt werden, siehe Seite 4.18!

Sealed chucking nut ER-MA must be ordered separately, see page 4.18!

Spannmutter ER-M ist inklusive!

Chucking nut ER-M is inclusive!

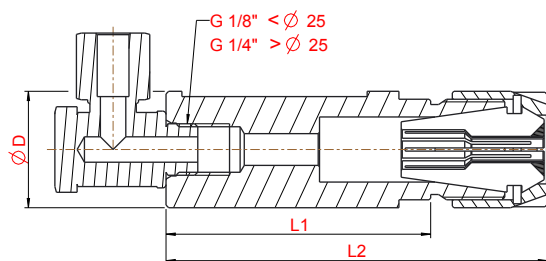

Beispiel:
mit Spannmutter ER-M

Example:
with chucking nut ER-M

Längendifferenz zwischen normaler und abdichtbarer Spannmutter in L2 Length difference between normal and sealed chucking nut in L2	Zange chuck	L2 mit abgedichteter Zange L2 with sealed chucking nut
	ER 16	+ 6,5 mm
ER 20	+ 7,5 mm	
ER 25	+ 7,5 mm	

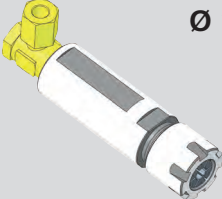
	Bestell Nummer Order Number	Bezeichnung Description	Ø D	Zange Chuck	L1	L2	
 Ø 16	11-0138	GZ.66.1620.11	16	ER 11	20	37	
	11-0139	GZ.66.1626.16	16	ER 16	26	46	
	11-0148	GZ.66.1630.11	16	ER 11	30	47	
	11-0586	GZ.66.1660.11	16	ER 11	60	77	
	11-0536	GZ.66.1660.16	16	ER 16	60	95	
	11-0462	GZ.66.16100.11	16	ER 11	100	117	
 Ø 3/4" (19,05)	11-0232	GZ.66.3440.11	3/4"	ER 11	40	57	
	11-0233	GZ.66.3440.16	3/4"	ER 16	40	62	
	11-0472	GZ.66.3450.11	3/4"	ER 11	50	67	
	11-0234	GZ.66.3450.16	3/4"	ER 16	50	72	
	11-0457	GZ.66.3460.11	3/4"	ER 11	60	77	
	11-0235	GZ.66.3470.16	3/4"	ER 16	70	92	
	11-0237	GZ.66.3470.20	3/4"	ER 20	70	94	
	11-0236	GZ.66.34120.16	3/4"	ER 16	120	142	
	 Ø 20	11-0664	GZ.66.2030.20	20	ER 20	30	54
11-0228		GZ.66.2040.11	20	ER 11	40	57	
11-0230		GZ.66.2040.16	20	ER 16	40	62	
11-0663		GZ.66.2045.20	20	ER 20	45	69	
11-0229		GZ.66.2060.11	20	ER 11	60	77	
11-0231		GZ.66.2060.16	20	ER 16	60	84	
11-1250		GZ.66.2080.16	20	ER 16	80	102	
11-1043		GZ.66.2090.11	20	ER 11	90	107	
11-0435		GZ.66.20100.11	20	ER 11	100	117	
11-0436		GZ.66.20100.16	20	ER 16	100	122	
11-0437		GZ.66.20100.20	20	ER 20	100	124	
 Ø 22		11-0150	GZ.66.2238.16	22	ER 16	38	60
		11-0151	GZ.66.2250.16	22	ER 16	50	72
		11-0149	GZ.66.2270.11	22	ER 11	70	87
	11-0152	GZ.66.2270.16	22	ER 16	70	92	
	11-0154	GZ.66.2270.20	22	ER 20	70	94	
	11-0156	GZ.66.2274.25	22	ER 25	74	122	
	11-1038	GZ.66.2280.16	22	ER 16	80	102	
11-1127	GZ.66.2290.16	22	ER 16	90	112		

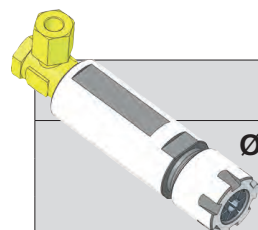
	Bestell Nummer Order Number	Bezeichnung Description	Ø D	Zange Chuck	L1	L2
 Ø 22	11-0153	GZ.66.22120.16	22	ER 16	120	142
	11-0155	GZ.66.22120.20	22	ER 20	120	144
	11-0157	GZ.66.22120.25	22	ER 25	120	168
Ø 25	11-0478	GZ.66.2560.16	25	ER 16	60	82
	11-0578	GZ.66.2560.20	25	ER 20	60	84
	11-0859	GZ.66.2580.16	25	ER 16	80	102
	11-0440	GZ.66.25100.16	25	ER 16	100	122
	11-0343	GZ.66.25100.20	25	ER 20	100	124
	11-0334	GZ.66.25150.20	25	ER 20	150	174
	11-0441	GZ.66.25150.25	25	ER 25	150	189
Ø 1" (25,4)	11-1284	GZ.66.1050.11	1"	ER 11	50	67
	11-0241	GZ.66.1050.16	1"	ER 16	50	72
	11-0244	GZ.66.1050.20	1"	ER 20	50	74
	11-0243	GZ.66.1060.16	1"	ER 16	60	82
	11-0245	GZ.66.1060.20	1"	ER 20	60	84
	11-1084	GZ.66.1090.16	1"	ER 16	90	112
	11-1083	GZ.66.1090.20	1"	ER 20	90	114
	11-1283	GZ.66.10100.11	1"	ER 11	100	117
	11-0242	GZ.66.10100.16	1"	ER 16	100	122
	11-0246	GZ.66.10100.20	1"	ER 20	100	124
	11-0200	GZ.66.10130.16	1"	ER 16	130	142
	11-0247	GZ.66.10130.20	1"	ER 20	130	154
	Ø 28	11-0140	GZ.66.2880.16	28	ER 16	80
11-0141		GZ.66.2880.20	28	ER 20	80	104
11-0434		GZ.66.2880.25	28	ER 25	80	115
Ø 30	11-1290	GZ.66.3050.16	30	ER 16	50	72
	11-1291	GZ.66.3050.20	30	ER 20	50	74
Ø 32	11-0658	GZ.66.3260.20	32	ER 20	60	86
	11-1126	GZ.66.3270.25	32	ER 25	70	106
	11-1143	GZ.66.3280.20	32	ER 20	80	108
	11-1082	GZ.66.3290.16	32	ER 16	90	112
	11-0846	GZ.66.32120.20	32	ER 20	120	144
	11-0555	GZ.66.32120.25	32	ER 25	120	156

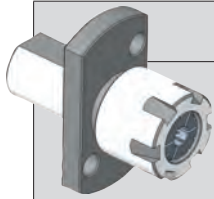
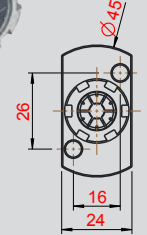
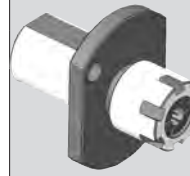
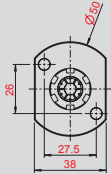
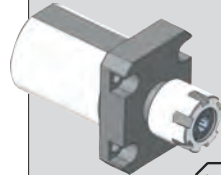
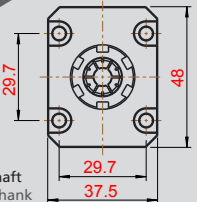
	Bestell Nummer Order Number	Bezeichnung Description	Ø D	Zange Chuck	L1	L2
 <p>STAR</p> <p>kein IK no IC</p> 	11-0485	GZ.66.1621.16	16	ER 16	21	48
	11-0558	GZ.66.2230.16.SR32	22	ER16	30	57
 <p>kein IK no IC</p> 	11-0606	GZ.66.2230.20.SR32	22	ER20	30	60
 <p>MAIER</p>  <p>IK durch den Schaft IC through the shank</p>	11-0335	GZ.66.3444.16	34	ER16	44	78
	11-0336	GZ.66.3444.20	34	ER20	44	80
	11-0337	GZ.66.3444.25	34	ER25	44	82

Klemmringe für Rundschaftwerkzeuge Clamping ring for round shank tools

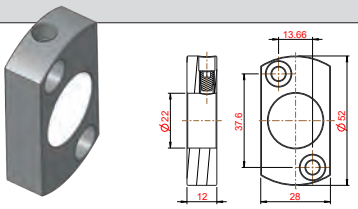
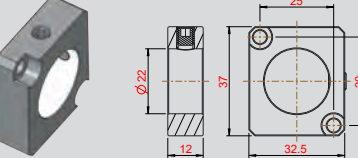
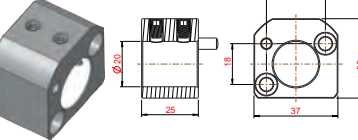
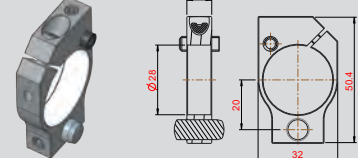
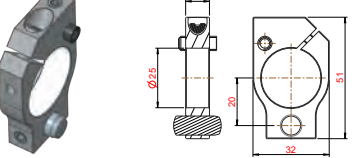
	Bestell Nummer Order Number	Bezeichnung Description
Für STAR for STAR Bohrbild S3 hole pattern S3 	4.130	Klemmring clamping ring
	4.341	Klemmring clamping ring
Für TSUGAMI for TSUGAMI 	4.201	Klemmring clamping ring
Für TRAUB for TRAUB 	4.220	Klemmring clamping ring
	4.278	Klemmring clamping ring

Hinweis / Note:

Die Klemmringe sind verwendbar an allen Rundschaftwerkzeugen, welche den passenden Durchmesser aufweisen.

The clamping rings can be used for all round shank tools, which have the suitable diameter.

Klemmringe für Rundschaftwerkzeuge Clamping ring for round shank tools

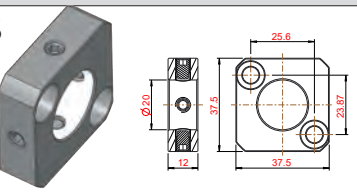
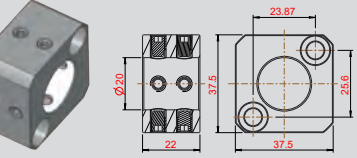
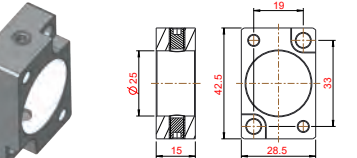
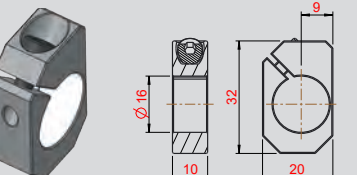
	Bestell Nummer Order Number	Bezeichnung Description
Für TORNOS for TORNOS 	4.283	Klemmring clamping ring
	4.285	Klemmring clamping ring
Für CITIZEN for CITIZEN Bohrbild C2 hole pattern C2 	4.351	Klemmring clamping ring
	4.337	Klemmring clamping ring

Hinweis / Note:

Die Klemmringe sind verwendbar an allen Rundschaftwerkzeugen, welche den passenden Durchmesser aufweisen.

The clamping rings can be used for all round shank tools, which have the suitable diameter.

Doppel-Spannzangenhalter Typ GZ.67

Double chuck holder type GZ.67



Spannmutter ER-M
ist inklusive!
Chucking nut ER-M
is inclusive!

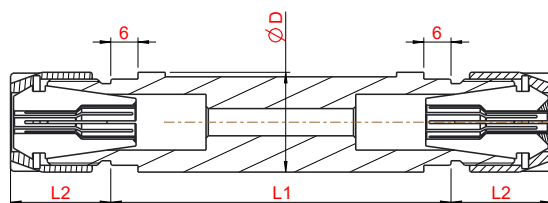

Beispiel:
mit GZ.67.2275.16

Example:
with GZ.67.2275.16

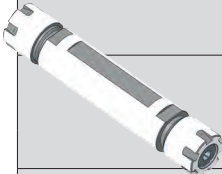
	Bestell Nummer Order Number	Bezeichnung Description	Ø D	Zange Chuck	L1	L2
 Ø 16	11-0158	GZ.67.1632.11	16	ER 11	32	17
	11-0159	GZ.67.1650.11	16	ER 11	50	17
Ø ¾" (19,05)	11-0253	GZ.67.3440.11	¾"	ER 11	40	17
	11-0454	GZ.67.3440.16	¾"	ER 16	40	22
	11-0256	GZ.67.3455.16	¾"	ER 16	55	22
	11-0254	GZ.67.3462.11	¾"	ER 11	62	17
	11-0257	GZ.67.3470.16	¾"	ER 16	70	22
	11-0255	GZ.67.3475.11	¾"	ER 11	75	17
Ø 20	11-0460	GZ.67.2030.11	20	ER 11	30	17
	11-0541	GZ.67.2040.16	20	ER 16	40	22
	11-0614	GZ.67.2040.11	20	ER 11	40	17
	11-0250	GZ.67.2050.16	20	ER 16	50	22
	11-0583	GZ.67.2050.11	20	ER 11	50	17
	11-0251	GZ.67.2065.16	20	ER 16	65	22
	11-0249	GZ.67.2065.11	20	ER 11	65	17
	11-0636	GZ.67.2080.16	20	ER 16	80	22
Ø 22	11-1113	GZ.67.2265.16	22	ER 16	65	22
	11-0161	GZ.67.2275.16	22	ER 16	75	22
	11-0160	GZ.67.22110.11	22	ER 11	110	17
	11-0162	GZ.67.22110.16	22	ER 16	110	22
Ø 25	11-0341	GZ.67.2580.16	25	ER 16	80	22
	11-0342	GZ.67.2580.20	25	ER 20	80	24
Ø 1" (25,4)	11-0259	GZ.67.1060.20	1"	ER 20	60	24
	11-0258	GZ.67.1065.16	1"	ER 16	65	22
	11-0260	GZ.67.1075.20	1"	ER 20	75	24
Ø 32	11-0164	GZ.67.3265.20	32	ER 20	65	24
	11-0165	GZ.67.3285.20	32	ER 20	85	24

**Doppel-Spannzangenhalter Typ GZ.79
mit Innenkühlung**
Double chuck holder type GZ.79
with coolant supply

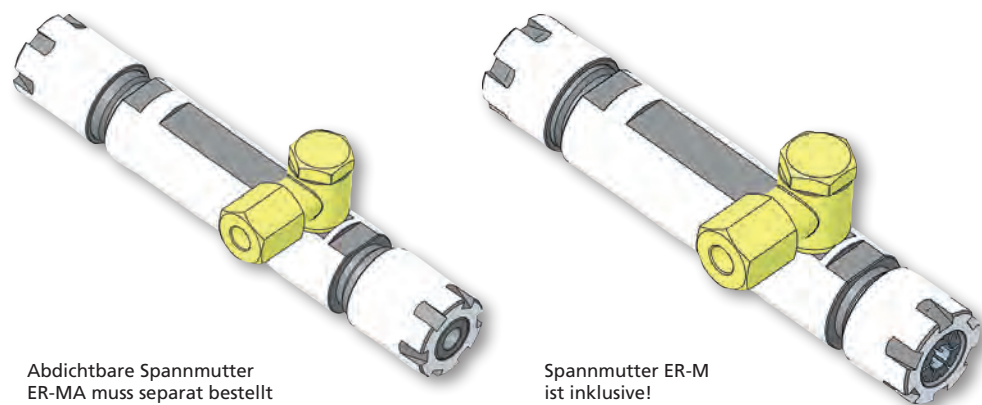

Abdichtbare Spannmutter ER-MA muss separat bestellt werden, siehe Seite 4.18!

Sealed chucking nut ER-MA must be ordered separately, see page 4.18!

Spannmutter ER-M ist inklusive!

Chucking nut ER-M is inclusive!

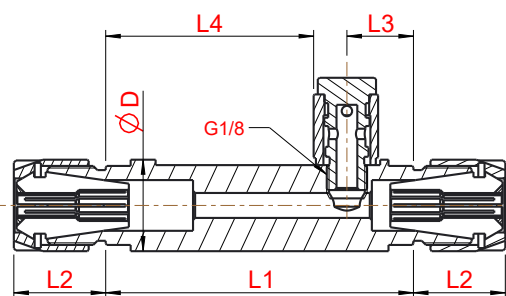

Beispiel:
mit Spannmutter ER-M

Example:
with chucking nut ER-M

Längen Differenz zwischen normaler und abdichtbarer Spannmutter in L2 Length difference between normal and sealed chucking nut in L2	Zange	L2 mit abgedichteter Zange L2 with sealed chucking nut
		ER 16
	ER 20	+ 7,5 mm
	ER 25	+ 7,5 mm

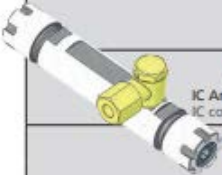
	Bestell Nummer Order Number	Bezeichnung Description	Ø D	Zange Chuck	L1	L2	L3	L4
	11-1012	GZ.79.1660.11	16	ER 11	60	17	14	39
	11-0871	GZ.79.3480.16	¾"	ER 16	80	25	16	57
Ø 20	11-0770	GZ.79.2075.16	20	ER 16	75	25	16	52
	11-1104	GZ.79.2090.16	20	ER 16	90	25	24	59
Ø 22	11-0692	GZ.79.2275.16	22	ER 16	75	25	16	52
	11-0807	GZ.79.22110.16	22	ER 16	110	25	15	90
Ø 25	11-1001	GZ.79.2580.16	25	ER 16	80	25	12	61
	11-0860	GZ.79.2595.20	25	ER 20	95	24	19	69
Ø 1" (25,4)	11-1150	GZ.79.1055.16	1"	ER 16	55	25	12	36
	11-0683	GZ.79.1065.16	1"	ER 16	65	25	12	45
	11-1050	GZ.79.1075.20	1"	ER 20	75	24	20	48
Ø 32	11-0861	GZ.79.3295.25	32	ER 25	95	26	22	66
	11-0862	GZ.79.3297.20	32	ER 20	97	24	19	71

Spannmutter ER-M
Chucking nut ER-M

Bestell Nummer Order Number	Bezeichnung Description	Ø D	L	M7x1
62.000.8	62.000.8.ER8	12	10,8	M10x0,75
62.000.11	62.000.11.ER11	16	12	M13x0,75
62.000.16	62.000.16.ER16	22	18	M19x1
62.000.20	62.000.20.ER20	28	19	M24x1
62.000.25	62.000.25.ER25	35	20	M30x1

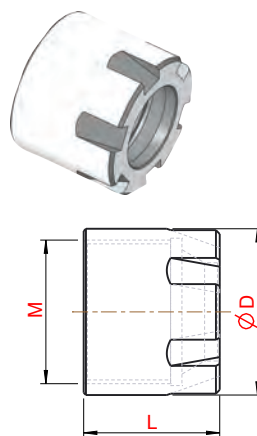

GRAF Spannmutter abdichtbar ER-MA
GRAF chucking nut sealed ER-MA

Bestell Nummer Order Number	Bezeichnung Description	Ø D	L	M7x1
62.600.16	62.600.16.ER16	22	24.5	M19x1
62.600.20	62.600.20.ER20	28	26.5	M24x1
62.600.25	62.600.25.ER25	35	27.5	M30x1

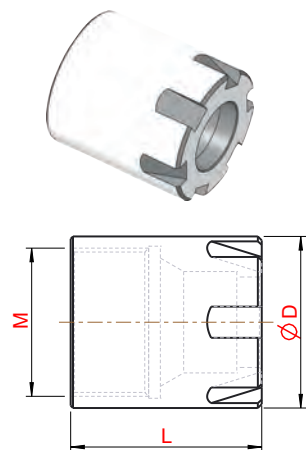

Dichscheiben für abdichtbare Spannmutter ER-MA
Sealing ring for chucking nut ER-MA

Bestell Nummer Order Number	Bezeichnung Description	Ø D
11-0002	Dichtscheibe ER16 - 3.5 - 4.0	4
11-0019	Dichtscheibe ER20 - 4.5 - 5.0	5
11-0059	Dichtscheibe ER25 - 8.5 - 9.0	9

Beim Bestellen bitte den Durchmesser angeben siehe Beispiel in der Tabelle
By order please specify the diameter see example in the table

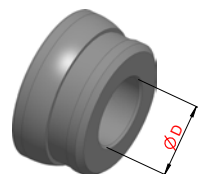

Ein Dichtscheiben-Satz kann auch komplett bestellt werden.
A sealing ring set can also be ordered complete.

Spannzangen
Collet chuck



Bild 1 / Picture 1

Die Spannzangen sind erhältlich sowohl als Standard (Bild1) als auch abgedichtet (Bild 2)

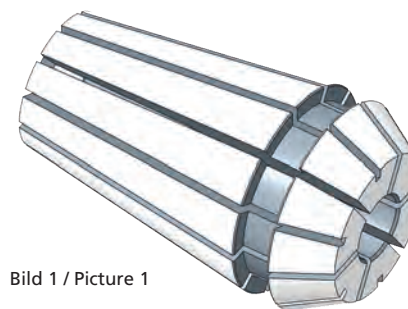

Bild 2 / Picture 2

The collet are available as standard (picture 1) and also as sealed (picture 2)

P_{max} = 40bar

Verfügbare Zangen Größe available chuck sizes		Lieferbar mit Innen-Ø available with inner Ø		Steigung in mm pitch in mm	
Standard default	Abgedichtet sealed	Standard default	Abgedichtet sealed	Standard default	Abgedichtet sealed
ER8		1 - 4.5		0.5	
ER11	ER11	3 - 7	1 - 6	0.5	0.5
ER16	ER16	3 - 10	3 - 10	0.5	0.5
ER20	ER20	3 - 13	3 - 13	0.5	0.5
ER25	ER25	2 - 16	6 - 16	0.5	0.5

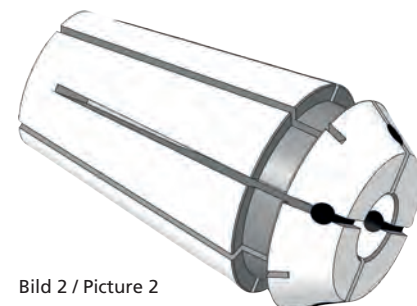
Beim Bestellen bitte Durchmesser angeben
By order please specify the diameter

Mehrkant-Drückgerät zum Innendrücken
Multi-sided hitting equipment for interior pressing

Typ GD.76

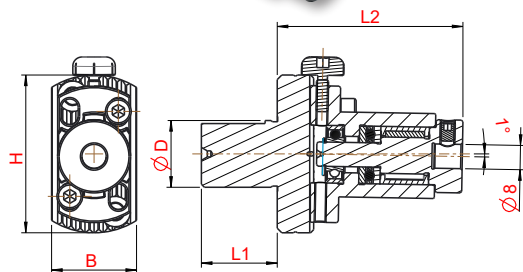
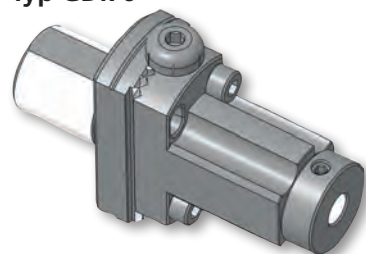

GD.76.002.01



GD.76.005.01
mit Aussparung
with gap





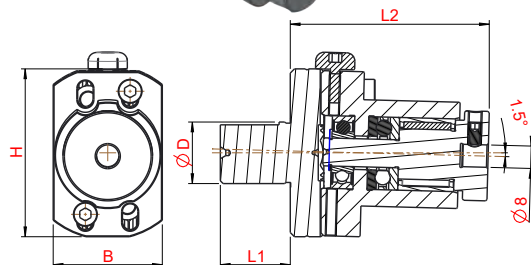
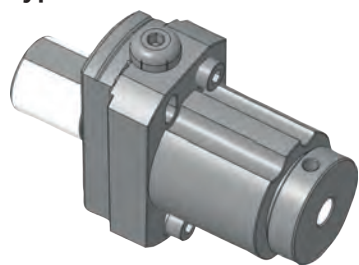

Typ GD.78

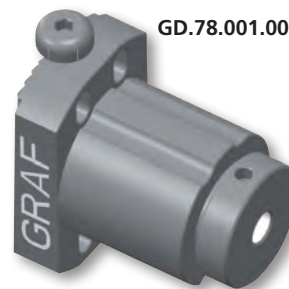

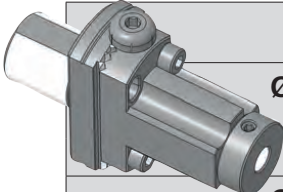
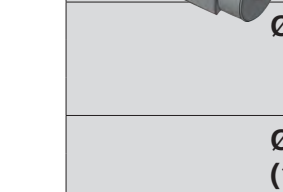
GD.78.001.00

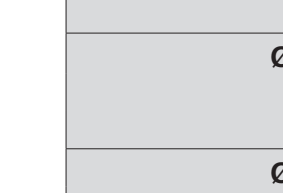

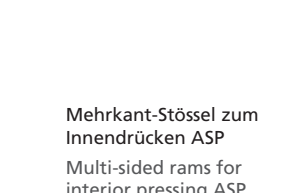
	Bestell Nummer Order Number	Bezeichnung Description	Ø D	L1	L2	B	H
	11-0219	GD.76.1621.08	16	21	55	24	45
	11-1269	GD.78.1640.08	16	40	71	39	60
	11-0306	GD.76.2030.08	20	30	57	24	45
	11-0125	GD.76.20100.08	20	100	57	24	45
	11-0307	GD.76.3440.08	¾"	40	55	24	45
	11-0718	GD.76.3450.08	¾"	50	57	24	45
	11-0221	GD.76.2238.08	22	38	57	24	45
	11-0222	GD.76.2250.08	22	50	57	24	45
	11-0223	GD.76.2270.08	22	70	57	24	45
	11-1076	GD.76.2570.08	25	70	57	24	45
	11-0691	GD.78.2570.08	25	70	71	39	60
	11-0309	GD.76.1060.08	1"	60	57	24	45
	11-0799	GD.78.1060.08	1"	60	71	39	60

Mehrkant-Stößel zum Innendrücken ASP
Multi-sided rams for interior pressing ASP

Abmasse und Stosstiefe (tmax = 15) nach Kundenwunsch
Dimensions (tmax = 15) according to customer drawing

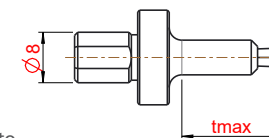

Bestell-Nr.	SW
GM.77.008.02	SK/SW 2
GM.77.008.03	SK/SW 3
GM.77.008.04	SK/SW 4
GM.77.008.05	SK/SW 5
GM.77.008.06	SK/SW 6
GM.77.008.08	SK/SW 8
GM.77.008.10	SK/SW 10

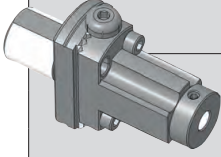
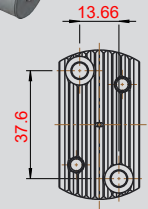
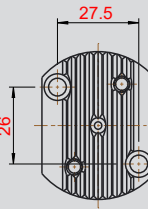
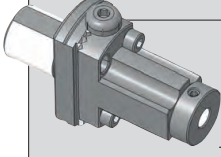
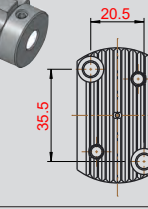
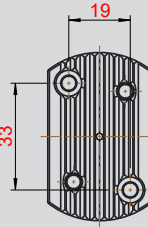
	Bestell Nummer Order Number	Bezeichnung Description	Ø D	L1	L2	B	H
 STAR 	11-0225	GD.76.2225.08.S3	22	25	61	28	52
	11-0775	GD.78.2225.08.S3	22	25	71	39	60
	11-0226	GD.76.2225.08.SR32	22	25	61	38	50
 HANWHA 	11-0127	GD.76.2540.08	25	40	58	31	52
	11-0146	GD.76.2560.08	25	60	61	32	52

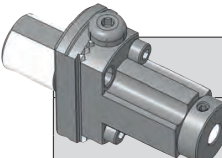
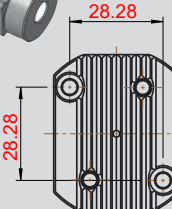
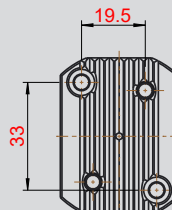
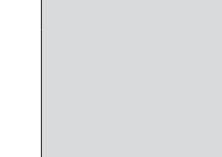
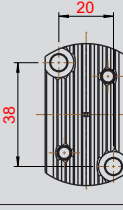
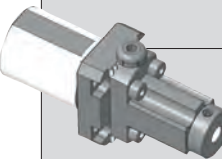
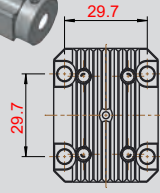
	Bestell Nummer Order Number	Bezeichnung Description	Ø D	L1	L2	B	H
 	11-0310	GD.76.3225.08.H5	32	25	61	36	48
	11-0574	GD.76.3335.08.H3	33	35	61	36	48
 TRAUB 	11-0547	GD.76.2880.08	28	80	61	30	52
 MAIER 	11-0373	GD.76.3444.08	34	44	64	37,5	48

**Gewindebohrerhalter Typ GB.68
Vierkantgeführt mit Längenausgleich**

**Square leded tap holder type GB.68
with length compensation**

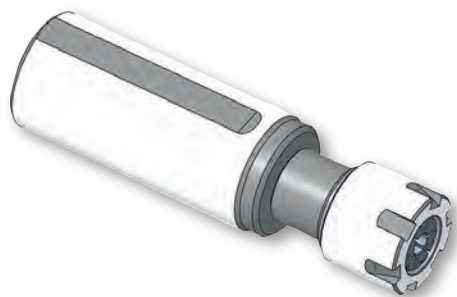

Spannmutter ER-M
ist inklusive!
Chucking nut ER-M
is inclusive!

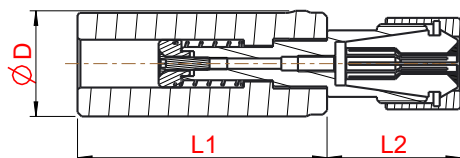

max. Längenauszug 7 mm
max. excerpt from length 7 mm

Beispiel:
mit GB.68.1060.16.D
Example:
with GB.68.1060.16.D

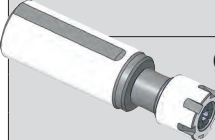
	Bestell Nummer Order Number	Bezeichnung Description	Ø D	Zange Chuck	L1	L2
 Ø 16	11-0180	GB.68.1642.11.D	16	ER 11	42	22
	11-0181	GB.68.1642.16.D	16	ER 16	42	32
	11-0996	GB.68.1642.20.D	16	ER 20	42	42
 Ø ¾" (19,05)	11-0273	GB.68.3440.11.D	¾"	ER 11	40	22
	11-0274	GB.68.3440.16.D	¾"	ER 16	40	32
	11-0992	GB.68.3440.20.D	¾"	ER 20	40	41
	11-0275	GB.68.3470.11.D	¾"	ER 11	70	22
	11-0276	GB.68.3470.16.D	¾"	ER 16	70	32
 Ø 20	11-0271	GB.68.2030.11.D	20	ER 11	30	22
	11-0272	GB.68.2030.16.D	20	ER 16	30	32
	11-0481	GB.68.2050.11.D	20	ER 11	50	22
	11-0482	GB.68.2050.16.D	20	ER 16	50	22
	11-0809	GB.68.2050.20.D	20	ER 20	50	41
 Ø 22	11-0182	GB.68.2225.11.D	22	ER 11	25	22
	11-0183	GB.68.2225.16.D	22	ER 16	25	32
	11-0184	GB.68.2270.11.D	22	ER 11	70	22
	11-0185	GB.68.2270.16.D	22	ER 16	70	32
	11-0857	GB.68.2270.20.D	22	ER 20	70	41
	11-0186	GB.68.22120.11.D	22	ER 11	120	22
	11-0187	GB.68.22120.16.D	22	ER 16	120	32
	11-1267	GB.68.22120.20.D	22	ER 20	120	41
 Ø 25	11-0175	GB.68.2570.11.D	25	ER 11	70	22
	11-0178	GB.68.2570.16.D	25	ER 16	70	32
	11-1020	GB.68.25150.11.D	25	ER 11	150	22
	11-0332	GB.68.25150.16.D	25	ER 16	150	32
	11-0333	GB.68.25150.20.D	25	ER 20	150	41
 Ø 1" (25,4)	11-0279	GB.68.10100.16.D	1"	ER 16	100	32
	11-1147	GB.68.10100.20.D	1"	ER 20	100	41
	11-1105	GB.68.1060.11.D	1"	ER 11	60	22
	11-1106	GB.68.1060.16.D	1"	ER 16	60	32
	11-1128	GB.68.1060.20.D	1"	ER 20	60	41

**Gewindeschneideisenhalter Typ GS.69
mit Längenausgleich**

screw threading holder type GS.69
with length compensation

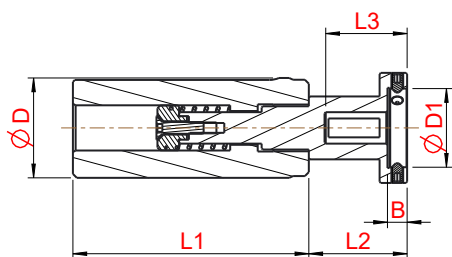
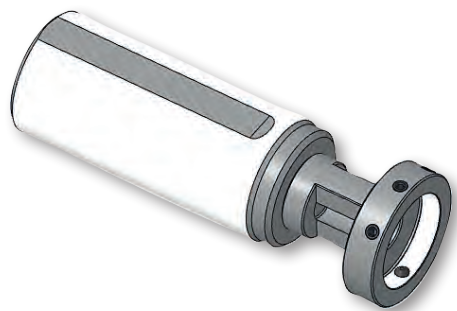

max. Längenauszug 7 mm
max. excerpt from length 7 mm

Beispiel:
mit GS.69.1060.2020.D

Example:
with GS.69.1060.2020.D

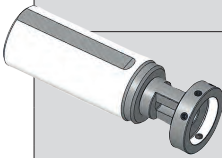
	Bestell Nummer Order Number	Bezeichnung Description	Ø D	Ø D1	L1	L2	L3	B
 Ø 16	11-0215	GS.69.1642.1620.D	16	16	42	25	20	5
	11-0216	GS.69.1642.2020.D	16	20	42	25	20	5
	11-0352	GS.69.1642.2030.D	16	20	42	35	30	6
Ø ¾" (19,05)	11-0300	GS.69.3440.1620.D	¾"	16	40	25	20	5
	11-0539	GS.69.3440.2020.D	¾"	20	40	25	20	5
	11-0301	GS.69.3440.2030.D	¾"	20	40	35	30	6
	11-1112	GS.69.3470.1620.D	¾"	16	70	25	20	5
	11-1258	GS.69.3470.2020.D	¾"	20	70	25	20	5
	11-0813	GS.69.3470.2030.D	¾"	20	70	35	30	6
Ø 20	11-0298	GS.69.2030.1620.D	20	16	30	25	20	5
	11-0771	GS.69.2030.2020.D	20	20	30	25	20	5
	11-0299	GS.69.2030.2030.D	20	20	30	35	30	6
	11-0695	GS.69.2050.1620.D	20	16	50	25	20	5
	11-1187	GS.69.2050.2020.D	20	20	50	25	20	5
	11-0484	GS.69.2050.2030.D	20	20	50	35	30	6
Ø 22	11-0217	GS.69.2270.1620.D	22	16	70	25	20	5
	11-0841	GS.69.2270.2020.D	22	20	70	25	20	5
	11-0218	GS.69.2270.2030.D	22	20	70	35	30	6
Ø 25	11-1041	GS.69.2570.1620.D	25	16	70	25	20	5
	11-1049	GS.69.2570.2020.D	25	20	70	25	20	5
	11-1044	GS.69.2570.2030.D	25	20	70	35	30	6
Ø 1" (25,4)	11-1099	GS.69.1060.1620.D	1"	16	60	25	20	5
	11-0296	GS.69.1060.2020.D	1"	20	60	25	20	5
	11-1100	GS.69.1060.2030.D	1"	20	60	35	30	6

**Pendelhalter Typ GP.70
für Reibahlen mit zylindrischem Schaft**

**Floating holder type GP.70
for reamers with cylindrical shaft**

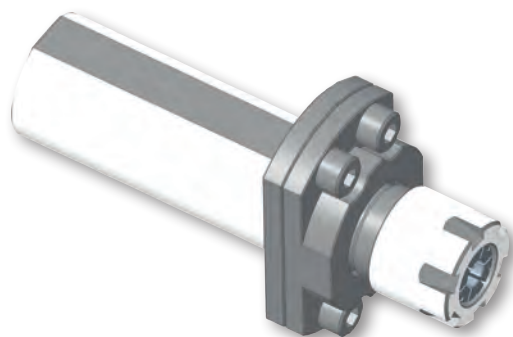

Spannmutter ER-M
ist inklusive!
Chucking nut ER-M
is inclusive!

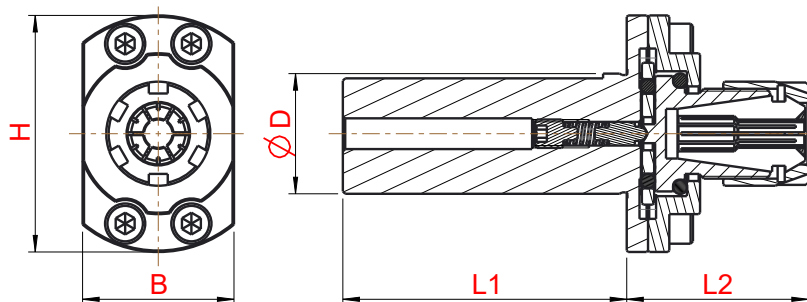

Beispiel:
mit GP.70.1060.16

Example:
with GP.70.1060.16

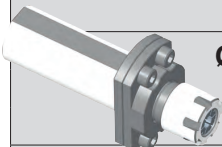
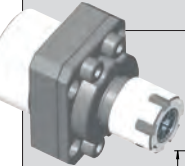
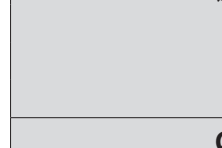
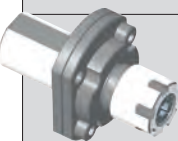
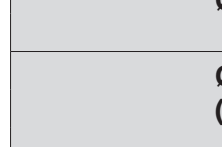
	Bestell Nummer Order Number	Bezeichnung Description	Ø D	Zange Chuck	L1	L2	B	H
	11-0188	GP.70.1621.11	16	ER11	21	33	24	45
	11-0563	GP.70.1630.16	16	ER16	30	39	32	50
	11-0540	GP.70.1650.11	16	ER11	50	33	24	45
Ø ¾" (19,05)	11-0282	GP.70.3440.11	¾"	ER11	40	33	24	45
	11-3219	GP.70.3440.16	¾"	ER16	40	39	32	50
	11-0283	GP.70.3470.11	¾"	ER11	70	33	24	45
Ø 20	11-0281	GP.70.2030.11	20	ER11	30	33	24	45
	11-0101	GP.70.2065.16	20	ER16	65	39	32	50
	11-0147	GP.70.20100.11	20	ER11	100	33	24	45
	11-0354	GP.70.20185.16	20	ER16	185	39	32	50
Ø 22	11-0191	GP.70.2270.11	22	ER11	70	33	24	45
	11-0453	GP.70.2270.16	22	ER16	70	39	32	50
	11-1265	GP.70.22120.11	22	ER11	120	33	24	45
	11-1055	GP.70.22120.16	22	ER16	120	39	32	50
Ø 25	11-0089	GP.70.2570.11	25	ER11	70	33	24	45
	11-0356	GP.70.25150.16	25	ER16	150	39	32	50
Ø 1" (25,4)	11-0284	GP.70.1060.11	1"	ER11	60	33	25	45
	11-1000	GP.70.1060.16	1"	ER16	60	39	32	50
Ø 28	11-0451	GP.70.2880.16	28	ER16	80	39	32	50
 	11-0438	GP.70.3420.16	34	ER16	20	46	37,5	48
 	11-0196	GP.70.2230.16. SR32	22	ER16	30	39	38	50

**Bohrstangenhalter Typ BS.71
mit Innenkühlung**

Boring bar holder type BS.71
with coolant supply

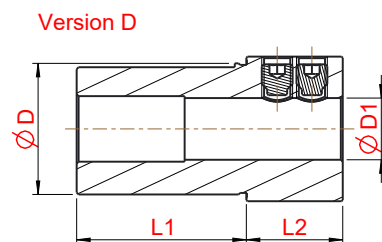
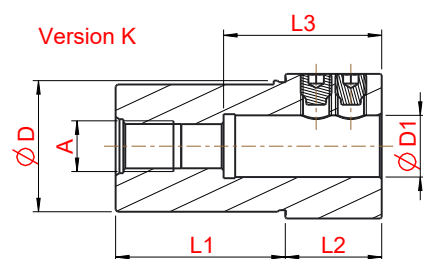
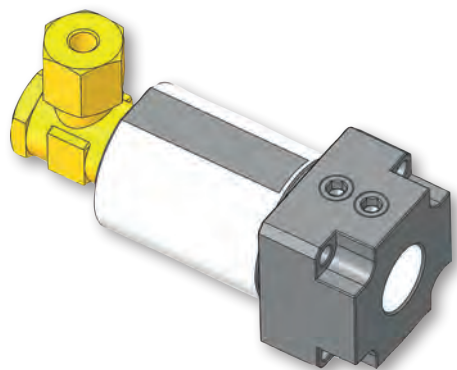

Beispiel:
mit BS.71.3334.16

Example:
with BS.71.3334.16

Hierfür passende Reduzierhülsen, siehe Seite 4.36!
Suitable adapter sleeve, see page 4.36!

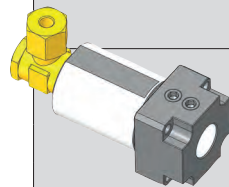
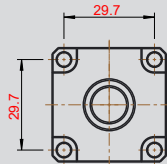
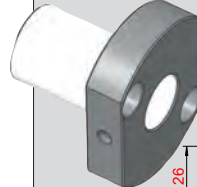
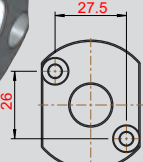
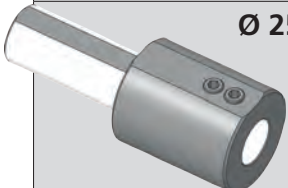
	Bestell Nummer Order Number	Bezeichnung Description	Ø D	Ø D1	L1	L2	L3	A
 	11-0425	BS.71.3420.16.D	34	16	20	25		
	11-0426	BS.71.3420.20.D	34	20	20	25		
	11-1211	BS.71.3444.12.D	34	12	44	25		
	11-0531	BS.71.3444.16.D	34	16	44	25		
	11-0532	BS7.1.3444.20.D	34	20	44	25		
	11-0533	BS.71.3444.25.D	34	25	44	25		
	11-0344	BS.71.3444.16.IK	34	16	44	25	41	G¼
	11-0534	BS.71.3444.20.IK	34	20	44	25	41	G¼
	11-0432	BS.71.3444.25.IK	34	25	44	25	41	G¼
	11-0446	BS.71.3444.25.4.IK	34	1"	44	25	41	G¼
 	11-0458	BS.71.2230.16.D	22	16	30	12		
	11-1061	BS.71.2558.20.IK	25	20	58	55	41	G1/8

**Bohrerhalter Typ BHE.72
mit Innenkühlung**

Drill holder type BHE.72
with coolant supply

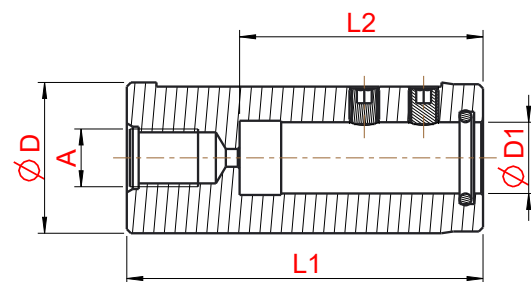
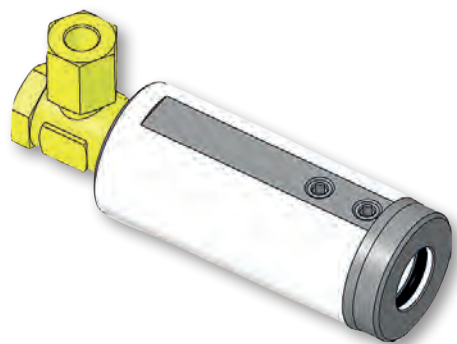

Beispiel:
mit BHE.72.1060.12

Example:
with BHE.72.1060.12

Hierfür passende Reduzierhülsen, siehe Seite 4.36!
Suitable adapter sleeve, see page 4.36!

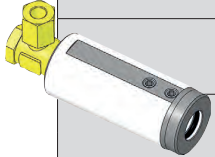
	Bestell Nummer Order Number	Bezeichnung Description	Ø D	Ø D1	L1	L2	A	
	Ø 16 Ø 3/4" (19,05)	11-0386	BHE.72.1660.10	16	10	60	30	G1/8
		11-0433	BHE.72.3450.06	3/4"	6	50	30	G1/8
		11-0840	BHE.72.3450.08	3/4"	8	50	30	G1/8
		11-1158	BHE.72.3450.10	3/4"	10	50	30	G1/8
		11-0382	BHE.72.3460.10	3/4"	10	60	41	G1/8
	11-0383	BHE.72.34100.10	3/4"	10	100	41	G1/8	
	Ø 20	11-0384	BHE.72.2050.10	20	10	50	30	G1/8
		11-0463	BHE.72.2060.10	20	10	60	38	G1/8
		11-1151	BHE.72.20150.06	20	6	150	40	G1/8
		11-1023	BHE.72.20150.08	20	8	150	40	G1/8
	Ø 22	11-0571	BHE.72.2260.06	22	6	60	36	G1/8
		11-0588	BHE.72.2260.08	22	8	60	36	G1/8
		11-0387	BHE.72.2260.10	22	10	60	40	G1/8
		11-0637	BHE.72.2260.12	22	12	60	40	G1/8
		11-1129	BHE.72.2260.14	22	14	60	40	G1/8
		11-0628	BHE.72.2275.06	22	6	75	36	G1/8
		11-0626	BHE.72.2275.10	22	10	75	41	G1/8
		11-0625	BHE.72.2275.12	22	12	75	45	G1/8
		11-0609	BHE.72.2275.16	22	16	75	40	G3/4
		11-0551	BHE.72.2295.16	22	16	95	45	G3/4
		11-0388	BHE.72.22100.10	22	10	100	40	G1/8
		11-1142	BHE.72.22100.12	22	12	100	45	G1/8
		11-0091	BHE.72.22125.12	22	12	125	45	G1/8
	Ø 25	11-1241	BHE.72.2560.06	25	6	60	35	G1/8
		11-1240	BHE.72.2560.08	25	8	60	36	G1/8
		11-1239	BHE.72.2560.10	25	10	60	40	G1/8
		11-1238	BHE.72.2560.12	25	12	60	41	G1/8
		11-1279	BHE.72.2560.14	25	14	60	41	G1/8
		11-0611	BHE.72.2560.16	25	16	60	41	G1/4
		11-1195	BHE.72.2580.06	25	6	80	30	G1/8
		11-0787	BHE.72.25100.10	25	10	100	40	G1/4
		11-0785	BHE.72.25100.16	25	16	100	48	G1/4

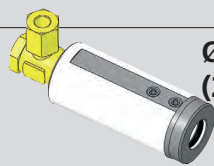
	Bestell Nummer Order Number	Bezeichnung Description	Ø D	Ø D1	L1	L2	A
 <p>Ø 1" (25,4)</p>	11-0620	BHE.72.1060.10	1"	10	60	41	G1/8
	11-1006	BHE.72.1060.12	1"	12	60	41	G1/8
	11-0986	BHE.72.1060.14	1"	14	60	41	G1/8
	11-0621	BHE.72.1060.16	1"	16	60	41	G1/8
	11-0730	BHE.72.10100.06	1"	6	100	36	G1/8
	11-0731	BHE.72.10100.08	1"	8	100	36	G1/8
	11-0732	BHE.72.10100.10	1"	10	100	40	G1/8
	11-0733	BHE.72.10100.12	1"	12	100	45	G1/8
	11-1091	BHE.72.10100.16	1"	16	100	48	G¼
<p>Ø 28</p>	11-0495	BHE.72.28100.06	28	6	100	36	M12x1,5
	11-0496	BHE.72.28100.08	28	8	100	36	M12x1,5
	11-0684	BHE.72.28100.10	28	10	100	40	M12x1,5
	11-0567	BHE.72.28100.12	28	12	100	40	M12x1,5
	11-1048	BHE.72.28100.16	28	16	100	40	M12x1,5
<p>Ø 32</p>	11-0864	BHE.72.3260.12	32	12	60	46	G1/8
	11-0455	BHE.72.3280.16	32	16	80	48	G¼
	11-0418	BHE.72.32100.06	32	6	100	36	G1/8
	11-0415	BHE.72.32100.08	32	8	100	36	G1/8
	11-0414	BHE.72.32100.10	32	10	100	41	G1/8
	11-0413	BHE.72.32100.12	32	12	100	45	G1/8
	11-0409	BHE.72.32100.16	32	16	100	48	G1/8
	11-0411	BHE.72.32100.20	32	20	100	50	G¼
	11-1022	BHE.72.32150.16	32	16	150	45	G¼
<p>Ø 33</p>	11-1132	BHE.72.3360.16	33	16	60	41	G¼

**Bohrerhalter Typ BHE.73
mit Kühlmittel-Anschluß**



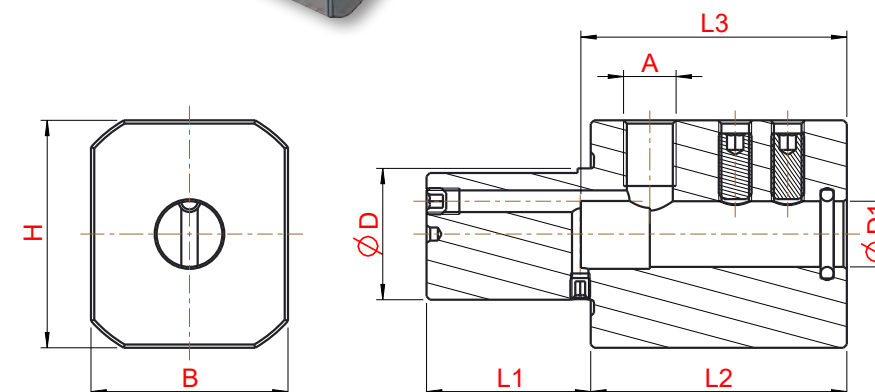
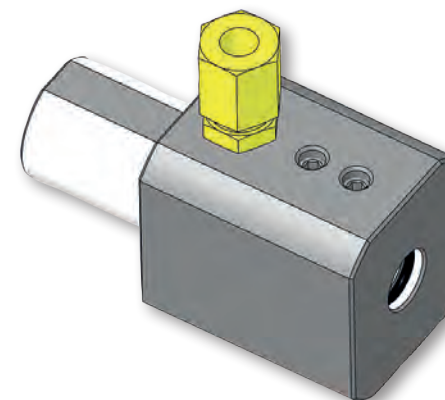

Drill holder type BHE.73
with coolant connection

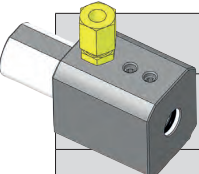
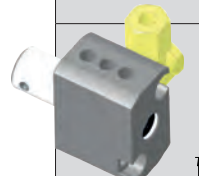
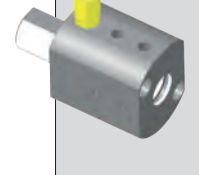
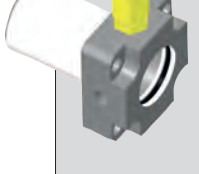
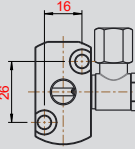

Beispiel:
mit BHE.73.2025.10

Example:
with BHE.73.2025.10

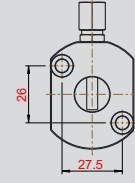
Hierfür passende Reduzierhülsen, siehe Seite 4.36!
Suitable adapter sleeve, see page 4.36!

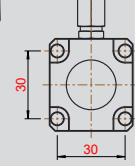
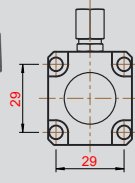
	Bestell Nummer Order Number	Bezeichnung Description	Ø D	Ø D1	L1	L2	L3	B	H	A	
	Ø 20	11-1060	BHE.73.2025.10	20	10	25	39	40	30	35	M8x1
		11-1047	BHE.73.2025.16	20	16	25	39	37	30	35	M8x1
	Ø 25	11-0805	BHE.73.2530.06	25	6	30	14	30	28	50	M8x1
		11-0868	BHE.73.2530.16	25	16	30	20	42	31	49	M8x1
	Ø 1" (25,4)	11-0834	BHE.73.1060.16	1"	16	60	20	42	31	49	M8x1
	STAR	11-0553	BHE.73.1621.10	16	10	21	33	48	24	44	G1/8
 											
 	11-1121	BHE.73.2225.16 SR32	22	16	30	50	41	38	49	M8x1	
 	11-1138	BHE.73.2535.22	25	22	35	18	50	37	41	M8x1	
	11-1139	BHE.73.3235.22	32	22	35	18	50	36	40	M8x1	

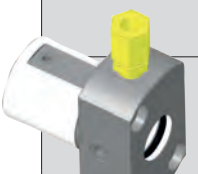
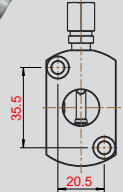
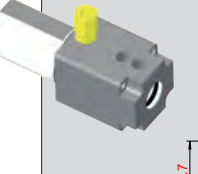
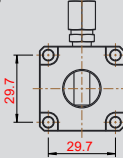
	Bestell Nummer Order Number	Bezeichnung Description	Ø D	Ø D1	L1	L2	L3	B	H	A	
 	HANWHA	11-0584	BHE.73.2830.12	28	12	30	20	42	31	52	M8x1
		11-0576	BHE.73.2830.16	28	16	30	39	37	30	35	M8x1
		11-1125	BHE.73.2840.18	28	18	40	35	41	32	48	M8x1
		11-1124	BHE.73.2840.25	28	25	40	45	41	32	48	M8x1
 	MAIER	11-0535	BHE.73.3444.16	34	16	44	52	44	37,5	37,5	M8x1
		11-0572	BHE.73.3444.20	34	20	44	52	44	37,5	37,5	M8x1
		11-0589	BHE.73.3444.25	34	25	44	52	52	37,5	37,5	M8x1
		11-0573	BHE.73.3444.1	34	1"	44	52	44	37,5	37,5	M8x1

Reduzierhülsen
Adapter sleeve

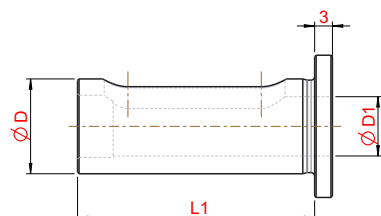

	Bestell Nummer Order Number	Bezeichnung Description	Ø D	Ø D1	L1
Ø 10	11-1090	RH.10.0324	10	3	24
	11-0445	RH.10.0424	10	4	24
	11-0501	RH.10.0524	10	5	24
	11-0502	RH.10.0624	10	6	24
	11-0504	RH.10.0824	10	8	24
Ø 16	11-3243	RH.16.0440	16	4	40
	11-0518	RH.16.0640	16	6	40
	11-0517	RH.16.0840	16	8	40
	11-0375	RH.16.1040	16	10	40
	11-0406	RH.16.1240	16	12	40
	11-0499	RH.16.1440	16	14	40
	Ø ¾" (19,05)	11-0889	RH.034.0640	¾"	6
11-0876		RH.034.0840	¾"	8	40
11-0649		RH.034.1040	¾"	10	40
11-0602		RH.034.1240	¾"	12	40
11-0603		RH.034.1640	¾"	16	40
Ø 20		11-1256	RH.20.0640	20	6
	11-1045	RH.20.0840	20	8	40
	11-0865	RH.20.1040	20	10	40
	11-0660	RH.20.1140	20	11	40
	11-0650	RH.20.1240	20	12	40
	11-1257	RH.20.1440	20	14	40
	11-0869	RH.20.1640	20	16	40
	11-0659	RH.20.1840	20	18	40

	Bestell Nummer Order Number	Bezeichnung Description	Ø D	Ø D1	L1
Ø 22	11-1272	RH.22.0640	22	6	40
	11-1273	RH.22.0840	22	8	40
	11-1146	RH.22.1040	22	10	40
	11-1237	RH.22.1240	22	12	40
	11-1063	RH.22.1450	22	14	50
	11-1034	RH.22.1640	22	16	40
	11-1064	RH.22.1850	22	18	50
	11-1065	RH.22.2050	22	20	50
Ø 25	11-0550	RH.25.0850	25	8	50
	11-0559	RH.25.1050	25	10	50
	11-0560	RH.25.1250	25	12	50
	11-1039	RH.25.1450	25	14	50
	11-1040	RH.25.1650	25	16	50
Ø 1" (25,4)	11-3216	RH.25.2050	25	20	50
	11-1025	RH.010.0650	1"	6	50
	11-1013	RH.010.0850	1"	8	50
	11-0749	RH.010.1050	1"	10	50
	11-0750	RH.010.1250	1"	12	50
	11-1026	RH.010.1450	1"	14	50
	11-0882	RH.010.1640	1"	16	40
	11-0800	RH.010.1650	1"	16	50
	11-1172	RH.010.1850	1"	18	50
	11-0883	RH.010.3450	1"	¾"	50
11-0801	RH.010.2050	1"	20	50	

Reduzierhülsen mit IK Innenkühlung Adapter sleeve with IC inner cooling



Bild 1
picture 1



Bild 2
picture 2

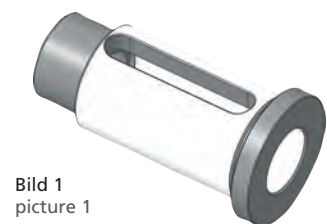

	Bestell Nummer Order Number	Bezeichnung Description	Ø D	Ø D1	L1	L2	A1	A2	
Bild 1 picture 1	Ø 16	11-0530	RH.16.0105.30IK	16	Horn Typ 105	36	28	M13x0,75	G1/8
		11-0529	RH.16.0330.IK	16	3	36	28	M13x0,75	G1/8
		11-0527	RH.16.0430.IK	16	4	36	28	M13x0,75	G1/8
		11-0526	RH.16.0530.IK	16	5	36	28	M13x0,75	G1/8
		11-0525	RH.16.0630.IK	16	6	36	28	M13x0,75	G1/8
		11-0523	RH.16.0830.IK	16	8	36	28	M13x0,75	G1/8
		11-0522	RH.16.1030.IK	16	10	36	28	M13x0,75	G1/8
	11-0521	RH.16.1230.IK	16	12	36	28	M13x0,75	G1/8	
Bild 2 picture 2	Ø 32	11-1135	RH.32.1260.IK	32	12	60	50	G1/4"	-
		11-1136	RH.32.2060.IK	32	20	60	50	G1/4"	-

	Bestell Nummer Order Number	Bezeichnung Description	Ø D	Ø D1	L1	L2	A1	A2	
Bild 1 picture 1	Ø 10	11-0520	RH.10.0105.24IK	10	Horn Typ 105	31	23	M10x1	M7x1
		11-0519	RH.10.0324.IK	10	3	30	22	M10x1	M7x1
		11-0500	RH.10.0424.IK	10	4	30	22	M10x1	M7x1
		11-0511	RH.10.0524.IK	10	5	30	22	M10x1	M7x1
		11-0512	RH.10.0624.IK	10	6	30	22	M10x1	M7x1
		11-0514	RH.10.0824.IK	10	8	30	22	M10x1	M7x1

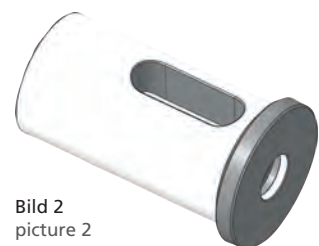
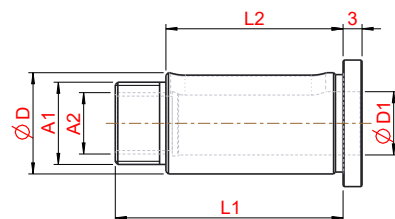
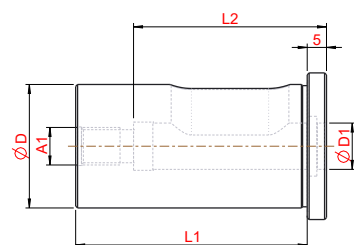
**Innendreh-Rundschafthalter Typ IR.105
für HORN-Supermini Typ 105 mit Innenkühlanschluss hinten**

Boring-round shank holder type IR.105
for HORN-Supermini type 105 with coolant connection back

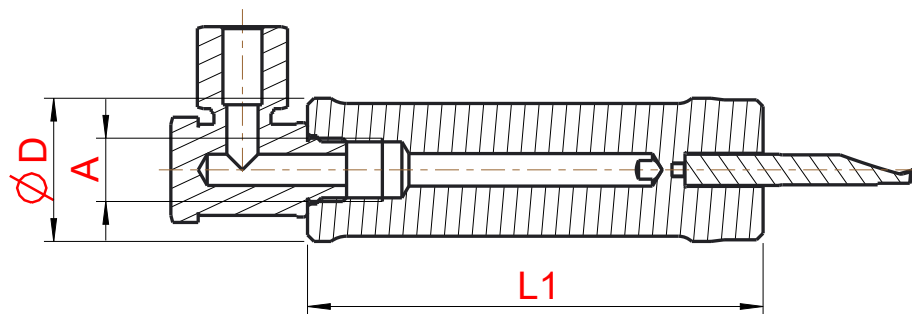
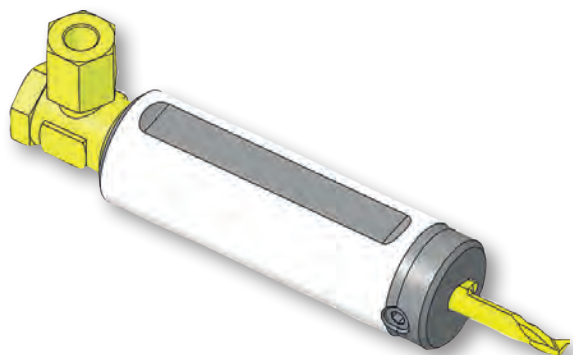

Beispiel:
mit IR.105.22.70
Example:
with IR.105.22.70

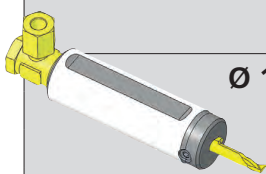
	Bestell Nummer Order Number	Bezeichnung Description	Ø D	L1	A
 Ø 16	06-1007	IR.105.16.30	16	30	G1/8
	06-1008	IR.105.16.50	16	50	G1/8
	06-1009	IR.105.16.70	16	70	G1/8
	06-1041	IR.105.16.100	16	100	G1/8
Ø 3/4" (19,05)	06-1021	IR.105.34.40	3/4"	40	G1/8
	06-1017	IR.105.34.50	3/4"	50	G1/8
	06-1022	IR.105.34.70	3/4"	70	G1/8
	06-1027	IR.105.34.100	3/4"	100	G1/8
Ø 20	06-1020	IR.105.20.30	20	30	G1/8
	06-1028	IR.105.20.50	20	50	G1/8
	06-1075	IR.105.20.100	20	100	G1/8
	06-1015	IR.105.20.170	20	170	G1/8
	06-1023	IR.105.20.185	20	185	G1/8
Ø 22	06-1010	IR.105.22.38	22	38	G1/8
	06-1011	IR.105.22.50	22	50	G1/8
	06-1012	IR.105.22.70	22	70	G1/8
	06-1018	IR.105.22.100	22	100	G1/8
	06-1013	IR.105.22.120	22	120	G1/8
	06-1077	IR.105.22.120.3 (Plattensitz Versatz 3mm/ insert position offset 3mm)	22	120	G1/8
Ø 25	06-1019	IR.105.25.100	25	100	G1/4
	06-1016	IR.105.25.150	25	100	G1/4
Ø 1" (25,4)	06-1024	IR.105.10.60	1"	60	G1/4
	06-1025	IR.105.10.100	1"	100	G1/4
Ø 28	06-2007	IR.105.28.80	28	80	G1/4

**Innendreh-Rundschafthalter Typ HORN IR.105 IKV
mit Innenkühl-Anschluss vorne**

Boring-round shank holder type HORN IR.105 IKV
with coolant connection in front

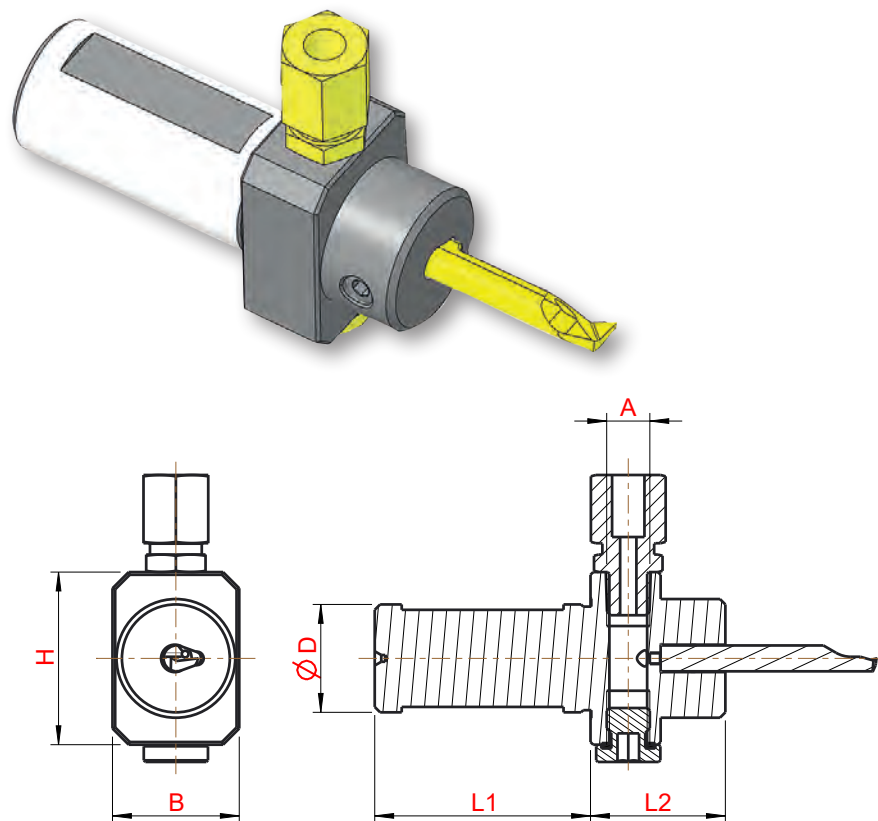

Beispiel:
mit IR.105.2040.IKV

Example:
with IR.105.2040.IKV

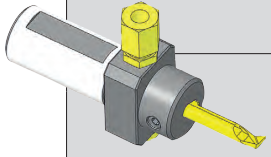
	Bestell Nummer Order Number	Bezeichnung Description	Ø D	L1	L2	B	H	A
 Ø 16	06-1031	IR.105.1640.IKV	16	40	25	24	32	M8x1
Ø 3/4" (19,05)	06-1029	IR.105.3440.IKV	3/4"	40	25	24	32	M8x1
	06-1044	IR.105.3480.IKV	3/4"	80	25	24	32	M8x1
Ø 20	06-1033	IR.105.2040.IKV	20	40	25	24	32	M8x1
Ø 22	06-1032	IR.105.2240.IKV	22	40	25	24	32	M8x1
Ø 25	06-1036	IR.105.2560.IKV	25	100	25	28	34	M8x1
Ø 1" (25,4)	06-1030	IR.105.1060.IKV	1"	60	25	28	34	M8x1
Ø 32	06-1038	IR.105.3260.IKV	32	60	25	36	40	M8x1
Ø 33	06-1043	IR.105.3337.IKV	33	37	25	38	42	M8x1

Innendreh-Rundschafthalter Typ Picco BS.75 mit Innenkühl-Anschluss hinten

Boring-round shank holder type Picco BS.75 with coolant connection back

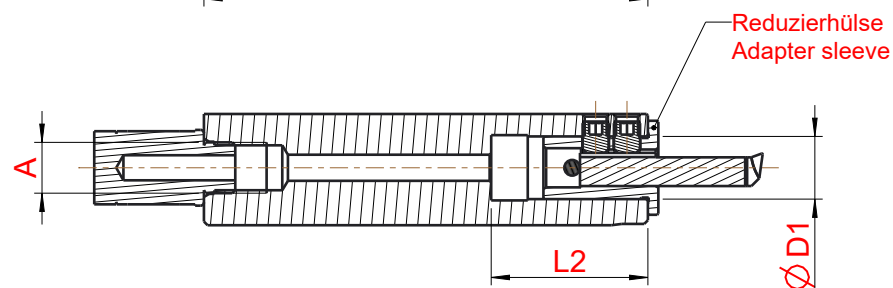
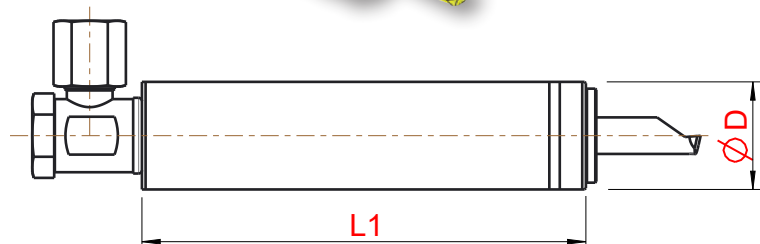
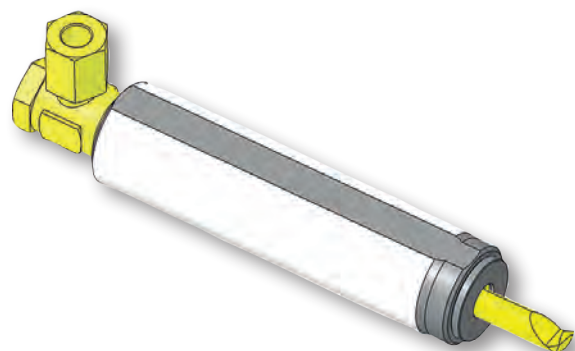

Beispiel:
mit BS.75.2285.12

Example:
with BS.75.2285.12

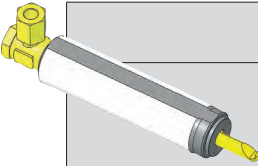
	Bestell Nummer Order Number	Bezeichnung Description	Ø D	Ø D1	L1	L2	A	
	11-1087	BS.75.34100.12	3/4"	12	100	30	G1/8	
								Ø 3/4" (19,05)
	11-0995	BS.75.2080.12	20	12	80	30	G1/8	
								Ø 20
	11-0755	BS.75.2270.12	22	12	70	30	G1/8	
								Ø 22
								11-1036
	11-0818	BS.75.22130.12	22	12	130	30	G1/8	
								Ø 22
	11-0858	BS.75.25100.12	25	12	100	30	G1/8	
								Ø 25
	11-1054	BS.75.10100.12	1"	12	100	30	G1/4	
								Ø 1" (25,4)

Reduzierhülsen für Innendreh-Rundschafthalter Typ Picco
Adapter sleeve for boring-round shank holder type Picco

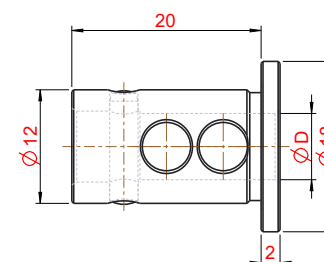

Bestell Nummer Order Number	Bezeichnung Description	ØD
11-0795	RH.12.0320	3
11-0819	RH.12.0420	4
11-0821	RH.12.0520	5
11-0824	RH.12.0620	6
11-0825	RH.12.0720	7
11-1037	RH.12.0820	8

Fräsdorne

Milling arbors

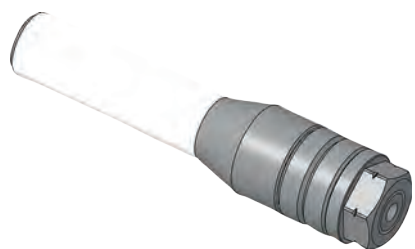

Bestell Nummer Order Number	Bezeichnung Description
10-0010	FD.1709

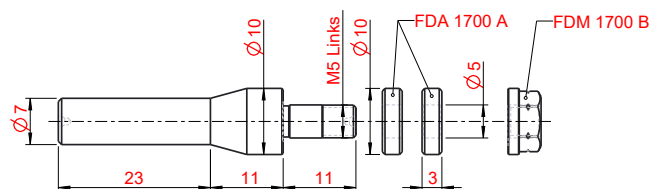

Fräsdorne

Milling arbors



Bestell Nummer Order Number	Bezeichnung Description
10-0012	FD.1711

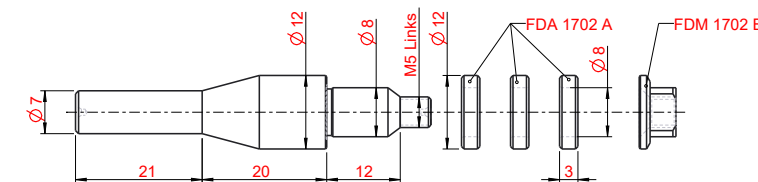

Bestell Nummer Order Number	Bezeichnung Description
10-0011	FD.1710

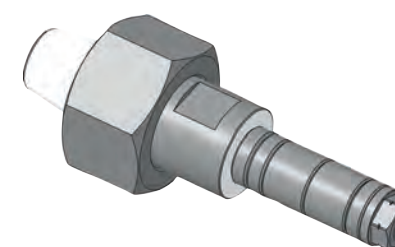
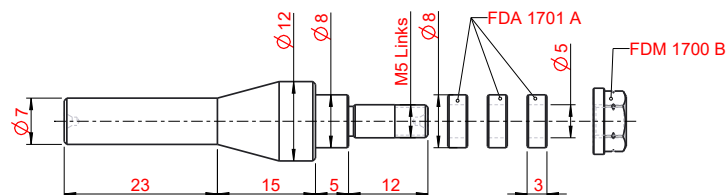

Bestell Nummer Order Number	Bezeichnung Description
10-0013	FD.1712

Hinweis/Note:
Beim bestellen die Mutter-Gewindegröße angeben.
By order please specify the nut thread size.

Spannmutter
clamping nut
FDM 1714C
(M=M19x1)
o.
FDM 1714D
(M=M22x1,5)

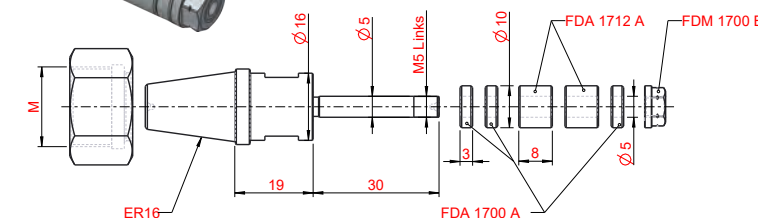

Fräsdorne

Milling arbors

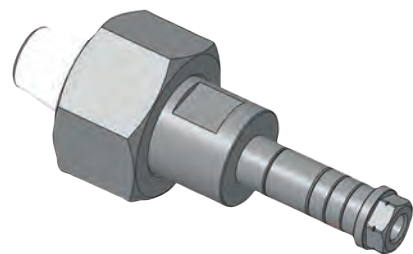

Bestell Nummer Order Number	Bezeichnung Description
10-0014	FD.1713

Spannmutter
clamping nut
FDM 1714C
(M=M19x1)
o.
FDM 1714D
(M=M22x1,5)

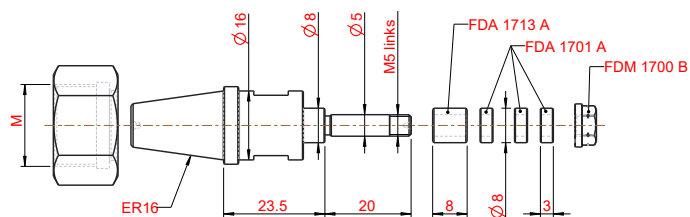

Bestell Nummer Order Number	Bezeichnung Description
10-0015	FD.1714

Hinweis/Note:
Beim bestellen die Mutter-Gewindegröße angeben.
By order please specify the nut thread size.

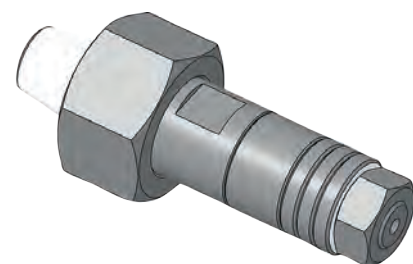

Spannmutter
clamping nut
FDM 1714C
(M=M19x1)
o.
FDM 1714D
(M=M22x1,5)

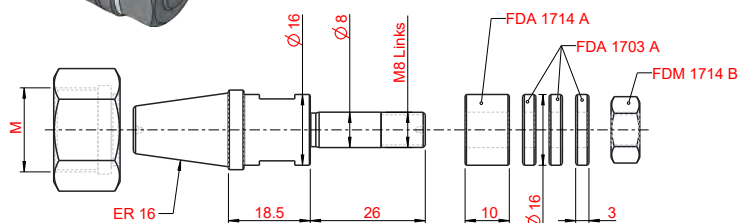

Fräsdorne

Milling arbors

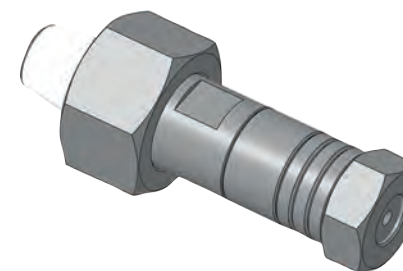

Bestell Nummer Order Number	Bezeichnung Description
10-0016	FD.1715

Spannmutter
clamping nut
FDM 1714C
(M=M19x1)
o.
FDM 1714D
(M=M22x1,5)

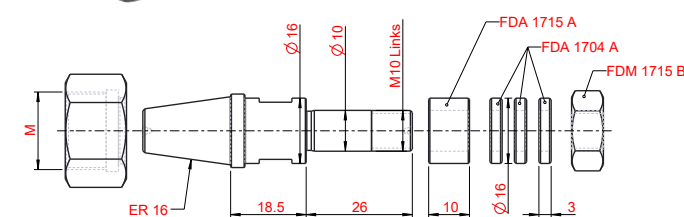

Bestell Nummer Order Number	Bezeichnung Description
10-0017	FD.1716

Hinweis/Note:
Beim bestellen die Mutter-Gewindegröße angeben.
By order please specify the nut thread size.

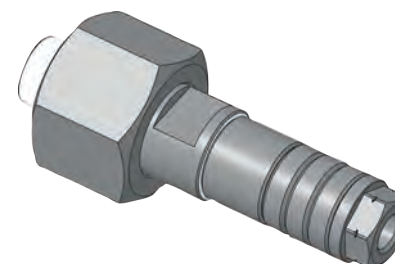

Spannmutter
clamping nut
FDM 1716C
(M=M13x0,75)
o.
FDM 1716D
(M=M14x0,75)

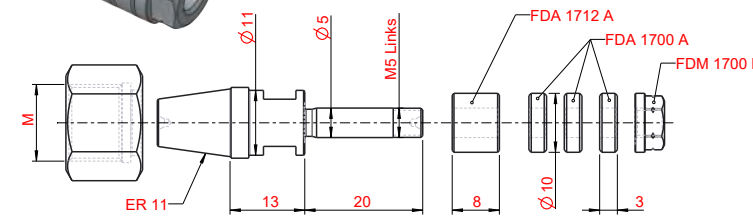

Fräsdorne

Milling arbors

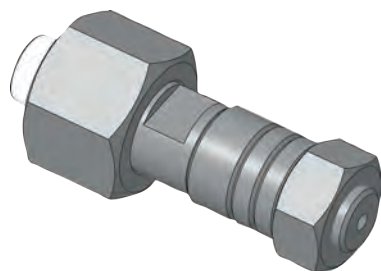

Bestell Nummer Order Number	Bezeichnung Description
10-0018	FD.1717

Spannmutter
clamping nut
FDM 1716C
(M=M13x0,75)
o.
FDM 1716D
(M=M14x0,75)

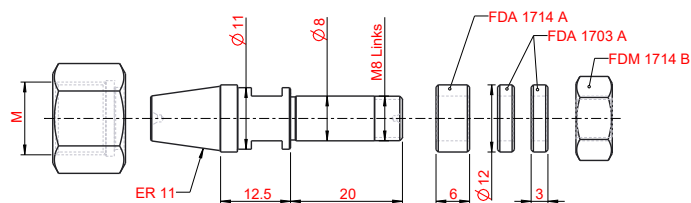

Bestell Nummer Order Number	Bezeichnung Description
10-0019	FD.1718

Hinweis/Note:
Beim bestellen die Mutter-Gewindegröße angeben.
By order please specify the nut thread size.

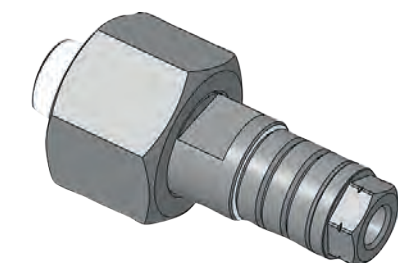

Spannmutter
clamping nut
FDM 1716C
(M=M13x0,75)
o.
FDM 1716D
(M=M14x0,75)

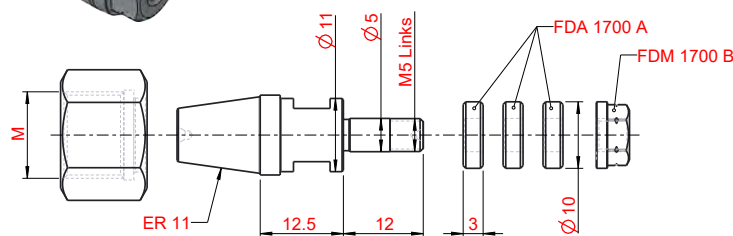

Fräsdorne

Milling arbors

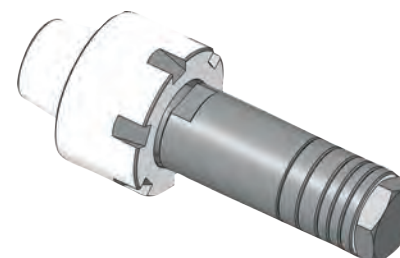

Bestell Nummer Order Number	Bezeichnung Description
10-0021	FD.1720

Spannmutter
clamping nut
ER25

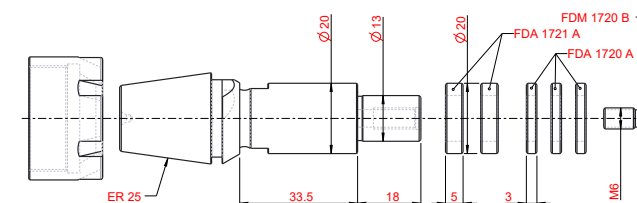

Bestell Nummer Order Number	Bezeichnung Description
10-0022	FD.1721

Hinweis/Note:
Beim bestellen die Mutter-Gewindegröße angeben.
By order please specify the nut thread size.

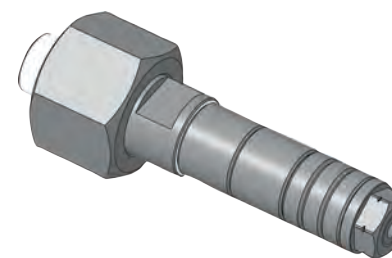

Spannmutter
clamping nut
FDM 1716C
(M=M13x0,75)
o.
FDM 1716D
(M=M14x0,75)

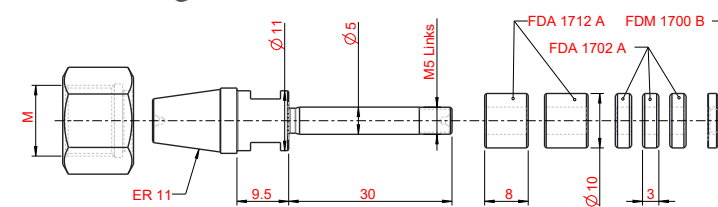

Fräsdorne

Milling arbors

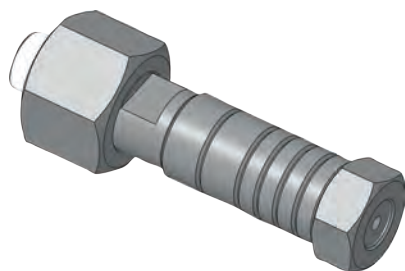

Bestell Nummer Order Number	Bezeichnung Description
10-0023	FD.1722

Spannmutter
clamping nut
FDM 1716C
(M=M13x0,75)
o.
FDM 1716D
(M=M14x0,75)

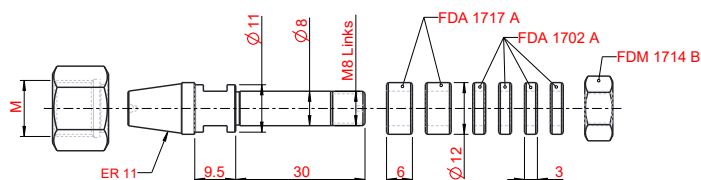

Hinweis/Note:
Beim bestellen die Mutter-Gewindegröße angeben.
By order please specify the nut thread size.

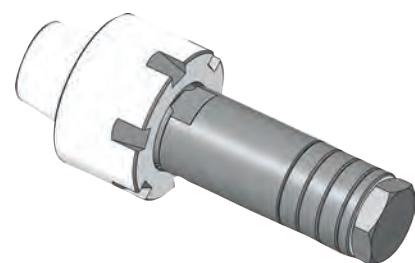

Bestell Nummer Order Number	Bezeichnung Description
10-0034	FD.1723

Spannmutter
clamping nut
ER25

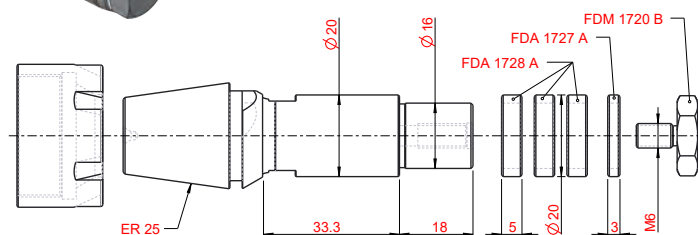

Fräsdorne

Milling arbors

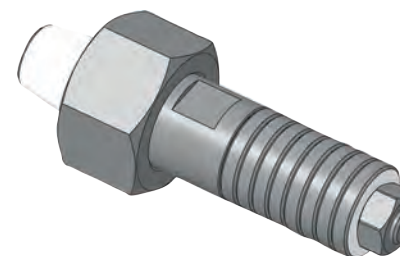

Bestell Nummer Order Number	Bezeichnung Description
10-0025	FD.1725

Spannmutter
clamping nut
FDM 1714C
(M=M19x1)
o.
FDM 1714D
(M=M22x1,5)

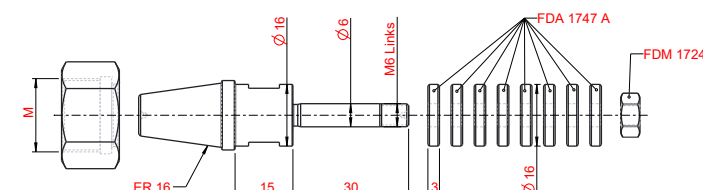

Bestell Nummer Order Number	Bezeichnung Description
10-0026	FD.1726

Hinweis/Note:
Beim bestellen die Mutter-Gewindegröße angeben.
By order please specify the nut thread size.

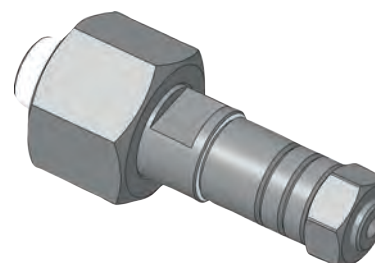

Spannmutter
clamping nut
FDM 1716C
(M=M13x0,75)
o.
FDM 1716D
(M=M14x0,75)

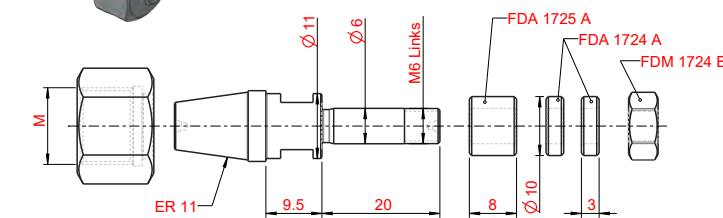

Fräsdorne

Milling arbors

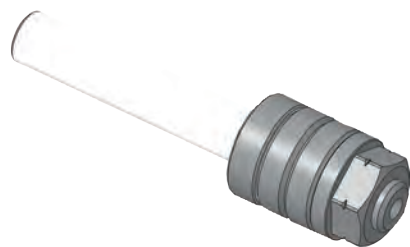

Bestell Nummer Order Number	Bezeichnung Description
10-0029	FD.1729

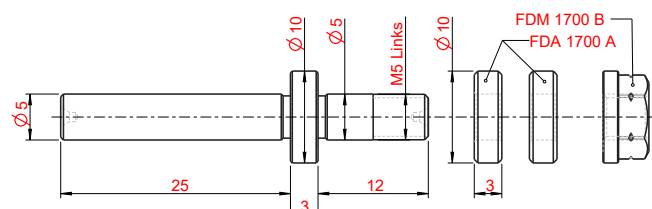

Bestell Nummer Order Number	Bezeichnung Description
10-0031	FD.1731

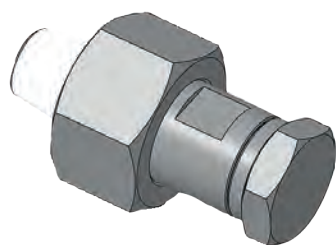

Hinweis/Note:
Beim bestellen die Mutter-Gewindegröße angeben.
By order please specify the nut thread size.

Spannmutter
clamping nut
FDM 1714C
(M=M19x1)
o.
FDM 1714D
(M=M22x1,5)

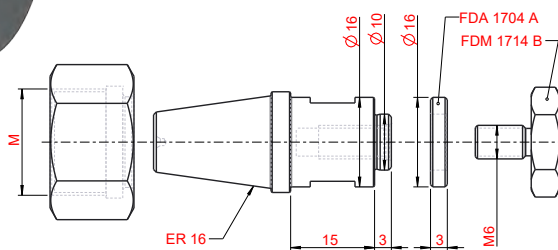

Fräsdorne

Milling arbors

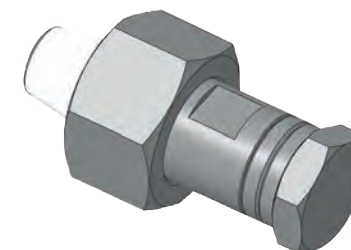

Bestell Nummer Order Number	Bezeichnung Description
10-0032	FD.1732

Spannmutter
clamping nut
FDM 1714C
(M=M19x1)
o.
FDM 1714D
(M=M22x1,5)

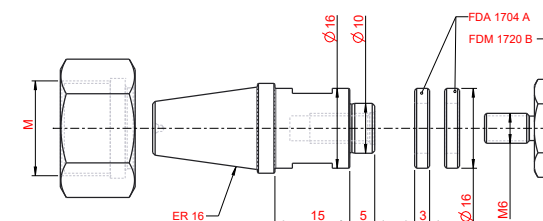

Bestell Nummer Order Number	Bezeichnung Description
10-0033	FD.1733

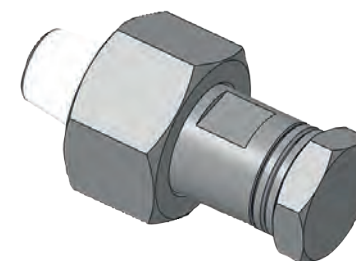

Hinweis/Note:
Beim bestellen die Mutter-Gewindegröße angeben.
By order please specify the nut thread size.

Spannmutter
clamping nut
FDM 1714C
(M=M19x1)
o.
FDM 1714D
(M=M22x1,5)

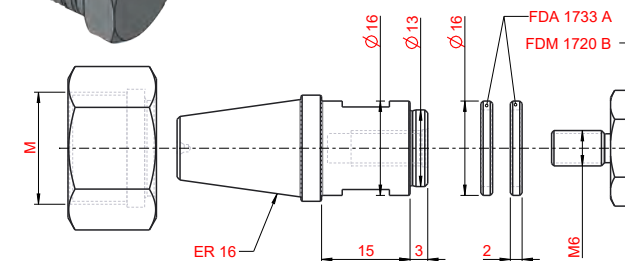

Fräsdorne

Milling arbors

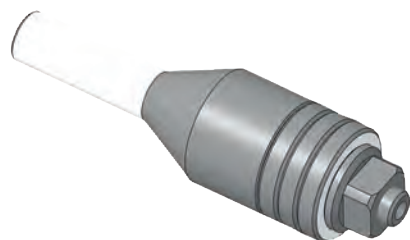

Bestell Nummer Order Number	Bezeichnung Description
10-0061	FD.1734

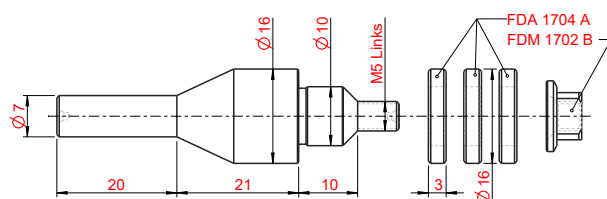

Bestell Nummer Order Number	Bezeichnung Description
10-0068	FD.1735

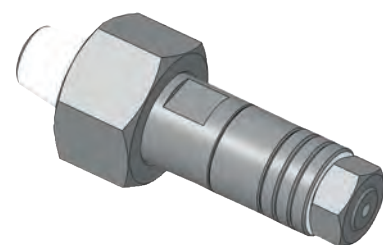

Hinweis/Note:
Beim bestellen die Mutter-Gewindegröße angeben.
By order please specify the nut thread size.

Spannmutter
clamping nut
FDM 1714C
(M=M19x1)
o.
FDM 1714D
(M=M22x1,5)

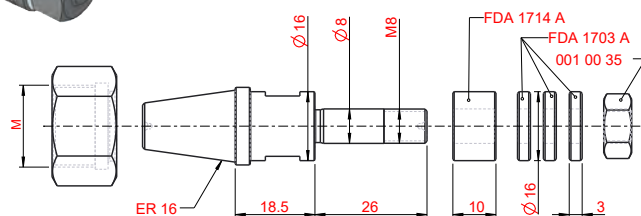

Fräsdorne

Milling arbors

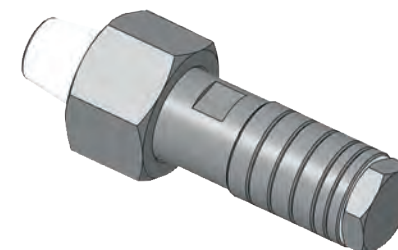

Bestell Nummer Order Number	Bezeichnung Description
10-0063	FD.1736

Spannmutter
clamping nut
FDM 1736B
(M=M24x1)
o.
FDM 1736C
(M=M25x1,5)

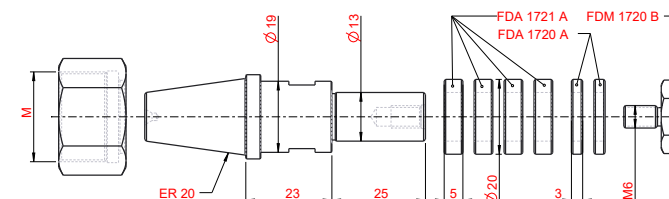

Hinweis/Note:
Beim bestellen die Mutter-Gewindegröße angeben.
By order please specify the nut thread size.

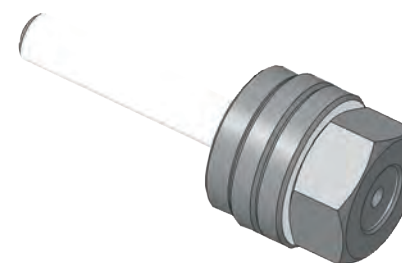

Bestell Nummer Order Number	Bezeichnung Description
10-0065	FD.1738

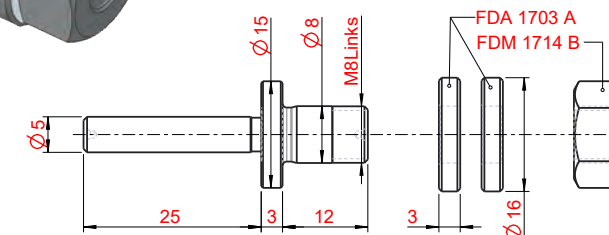

Fräsdorne

Milling arbors

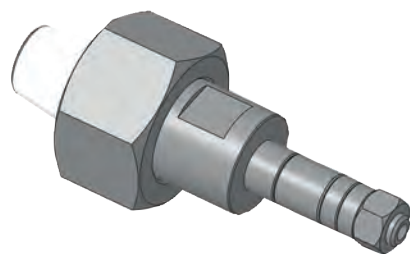

Bestell Nummer Order Number	Bezeichnung Description
10-0072	FD.1745

Spannmutter
clamping nut
FDM 1714C
(M=M19x1)
o.
FDM 1714D
(M=M22x1,5)

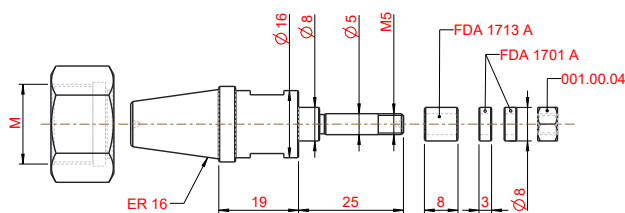

Bestell Nummer Order Number	Bezeichnung Description
10-0073	FD.1746

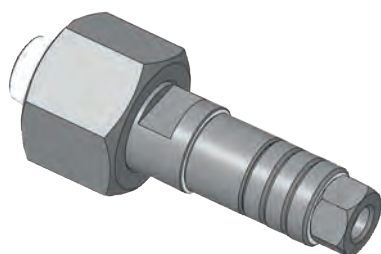

Hinweis/Note:
Beim bestellen die Mutter-Gewindegröße angeben.
By order please specify the nut thread size.

Spannmutter
clamping nut
FDM 1716C
(M=M13x0,75)
o.
FDM 1716D
(M=M14x0,75)

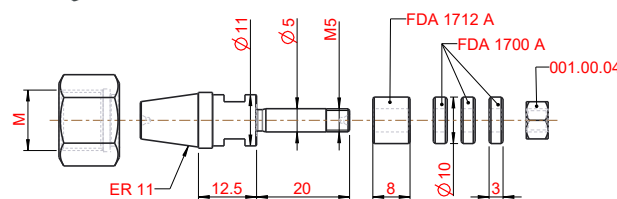

Fräsdorne

Milling arbors

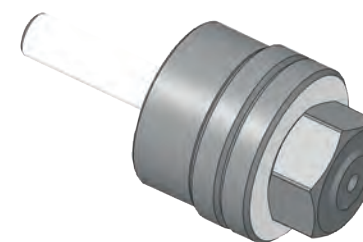

Bestell Nummer Order Number	Bezeichnung Description
10-0074	FD.1747

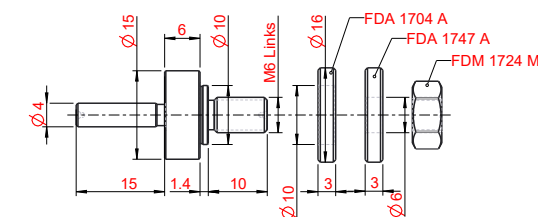

Bestell Nummer Order Number	Bezeichnung Description
10-0075	FD.1748

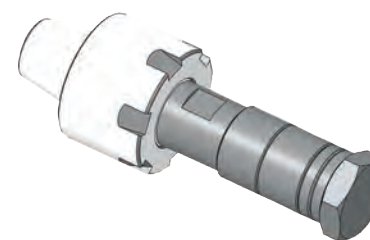

Spannmutter
clamping nut
ER20

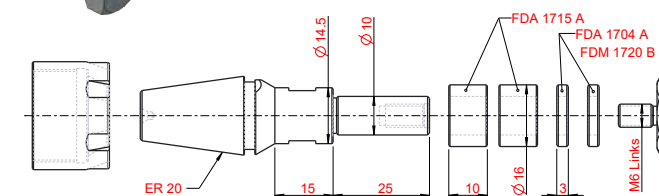

Fräsdorne

Milling arbors

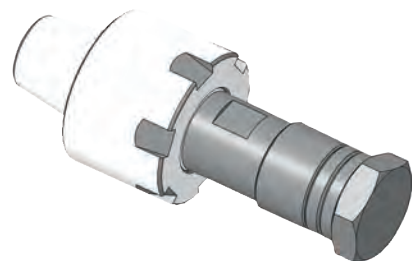

Bestell Nummer Order Number	Bezeichnung Description
10-0076	FD.1749

Spannmutter
clamping nut
ER20

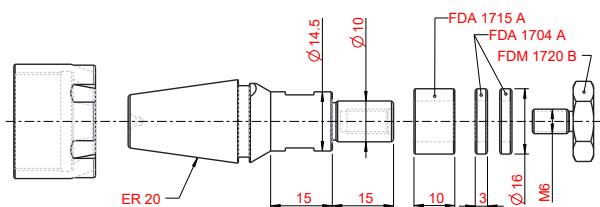

Fräsdorne

Milling arbors

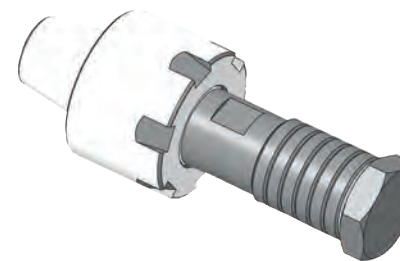

Bestell Nummer Order Number	Bezeichnung Description
10-0086	FD.1752

Spannmutter
clamping nut
ER20

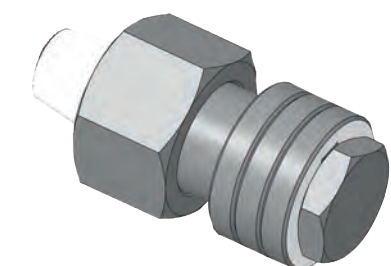
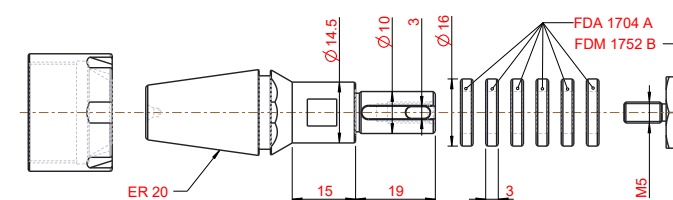

Bestell Nummer Order Number	Bezeichnung Description
10-0081	FD.1751

Hinweis/Note:
Beim bestellen die Mutter-Gewindegröße angeben.
By order please specify the nut thread size.

Spannmutter
clamping nut
FDM 1736B
(M=M24x1)
o.
FDM 1736C
(M=M25x1,75)

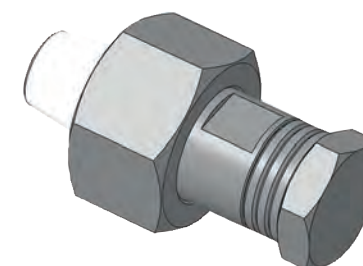
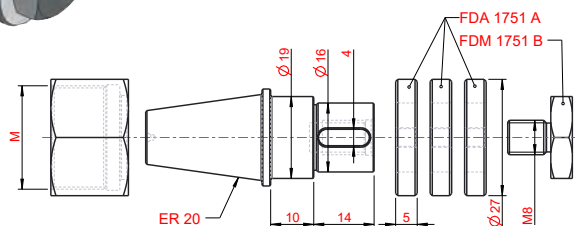

Bestell Nummer Order Number	Bezeichnung Description
10-0087	FD.1753

Hinweis/Note:
Beim bestellen die Mutter-Gewindegröße angeben.
By order please specify the nut thread size.

Spannmutter
clamping nut
FDM 1714C
(M=M19x1)
o.
FDM 1714D
(M=M22x1,5)

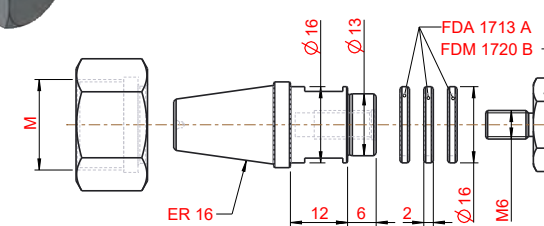

Fräsdorne

Milling arbors

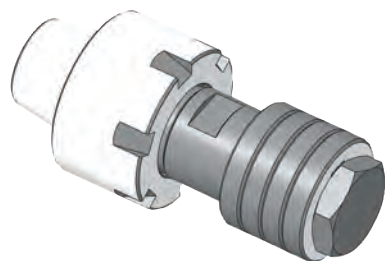

Bestell Nummer Order Number	Bezeichnung Description
10-0093	FD.1755

Spannmutter
clamping nut
ER25

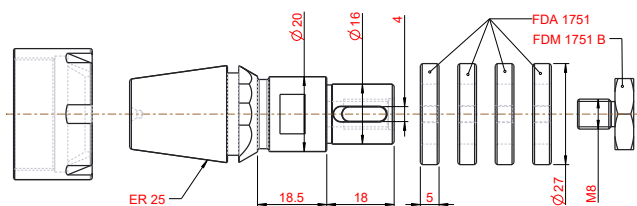

Bestell Nummer Order Number	Bezeichnung Description
10-0030	FD.1756

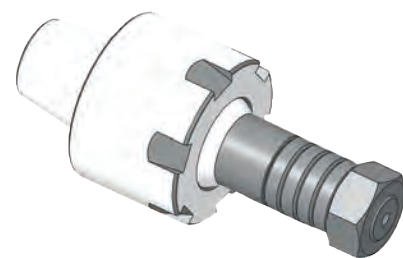

Spannmutter
clamping nut
ER20

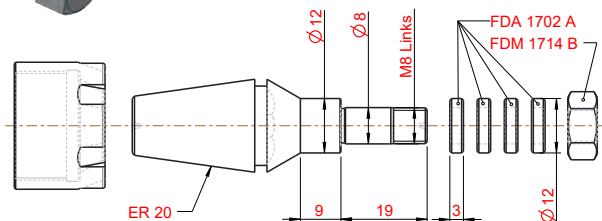

Fräsdorne

Milling arbors

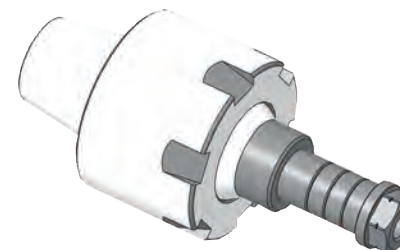

Bestell Nummer Order Number	Bezeichnung Description
10-0094	FD.1757

Spannmutter
clamping nut
ER20

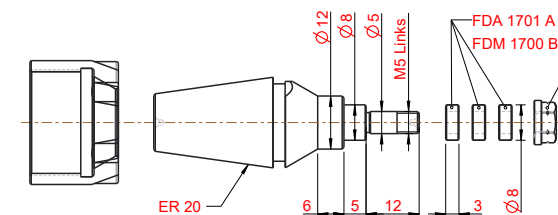

Bestell Nummer Order Number	Bezeichnung Description
10-0071	FD.1761

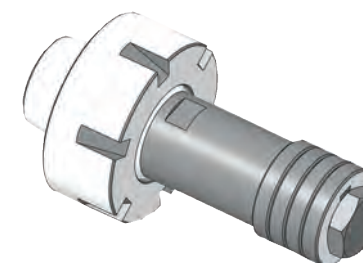

Spannmutter
clamping nut
ER32

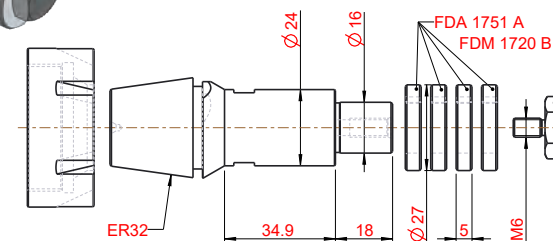

Fräsweldon ER16
Milling weldon ER16

Passend für alle ER16 Spannzangen Aufnahmen
Suitable for al ER16 chuck holder

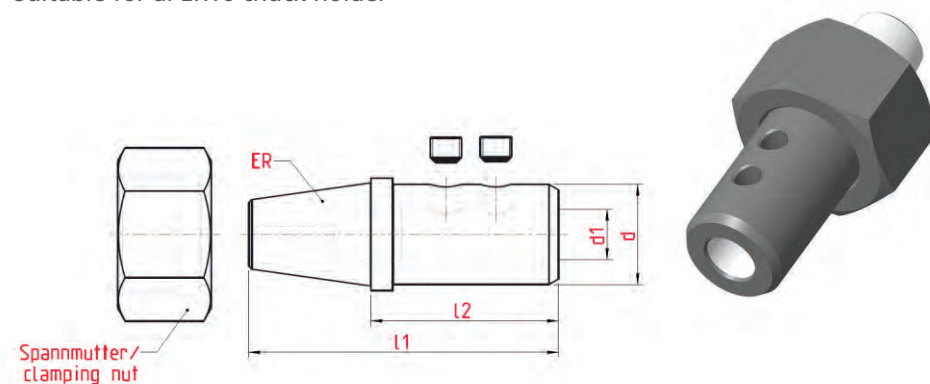

Art der Spannmutter muss beim Bestellen angegeben werden. Typ of the clamping nut must be specified when ordering.

Bestell Nummer Order Number	Bezeichnung Description	ER	l1	l2	d	d1	Spannmutter Clamping nut
10-0201	FWD.1630.08	16	49,5	30	14	8	FDM 1714 C (M19x1) FDM 1714 D (M19x1,5)
10-0200	FWD.1630.06	16	49,5	30	14	6	
10-0209	FWD.1630.05	16	49,5	30	14	5	
10-0205	FWD.1630.04	16	49,5	30	14	4	
10-0206	FWD.1630.03	16	49,5	30	14	3	

Abmessungen in mm
Dimensions in mm

Hinweis/Note:
IK durch den Halter möglich.
coolant through the holder is possible

Ersatzteile / Spare parts	
Für Halter for holder	
FWD.1630.08	002.00.77
FWD.1630.06	002.00.40
FWD.1630.05	002.00.40
FWD.1630.04	002.00.28
FWD.1630.03	002.00.28

Fräsweldon ER20
Milling weldon ER20

Passend für alle ER20 Spannzangen Aufnahmen
Suitable for al ER20 chuck holder

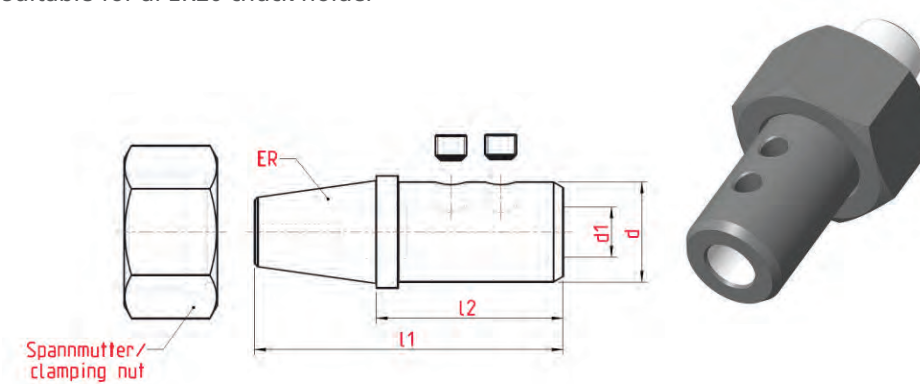

Art der Spannmutter muss beim Bestellen angegeben werden. Typ of the clamping nut must be specified when ordering.

Bestell Nummer Order Number	Bezeichnung Description	ER	l1	l2	d	d1	Spannmutter Clamping nut
10-0202	FWD.2030.06	20	57	30	16	6	FDM 1736 B (M24x1) FDM 1736 C (M25x1,5)
10-0203	FWD.2030.08	20	57	30	19	8	
10-0204	FWD.2030.10	20	57	30	19	10	
10-0207	FWD.2025.03	20	53	26	12	3	
10-0208	FWD.2025.04	20	53	26	12	4	

Abmessungen in mm
Dimensions in mm

Hinweis/Note:
IK durch den Halter möglich.
coolant through the holder is possible

Ersatzteile / Spare parts	
Für Halter for holder	
FWD.2030.06	002.00.40
FWD.2030.08	002.00.11
FWD.2030.10	002.00.70
FWD.2025.03	002.00.47
FWD.2025.04	002.00.46

Fräsreduzierung ER11
Milling reduction ER11

Passend für alle ER11 Spannzangen Aufnahmen
Suitable for al ER11 chuck holder

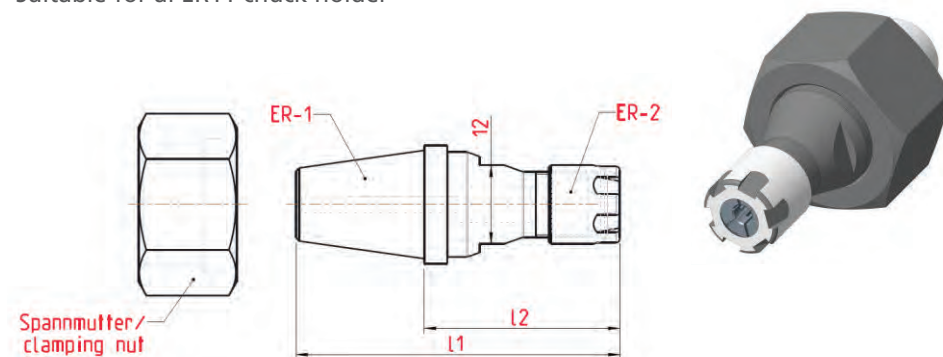

Art der Spannmutter muss beim Bestellen angegeben werden. Typ of the clamping nut must be specified when ordering.

Bestell Nummer Order Number	Bezeichnung Description	ER-1	I1	I2	ER-2	Spannmutter Clamping nut
10-0305	FRZ.1125.08	11	37	25	8	FDM 1716 C (M13x0,75) FDM 1716 D (M14x0,75)

Abmessungen in mm
Dimensions in mm

Hinweis/Note:

IK durch den Halter möglich.
coolant through the holder is possible

Ersatzteile / Spare parts

62.000.8

Fräsreduzierung ER16
Milling reduction ER16

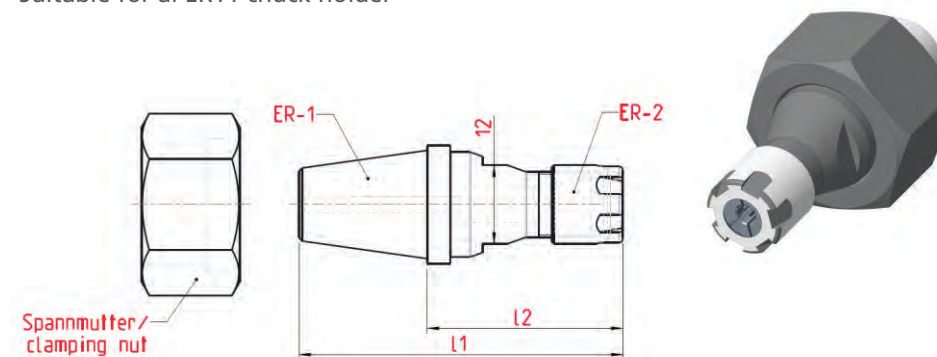
Passend für alle ER11 Spannzangen Aufnahmen
Suitable for al ER11 chuck holder





Art der Spannmutter muss beim Bestellen angegeben werden. Typ of the clamping nut must be specified when ordering.

Bestell Nummer Order Number	Bezeichnung Description	ER-1	I1	I2	ER-2	Spannmutter Clamping nut
10-0300	FRZ.1630.08	16	49	30	8	FDM 1714 C (M19x1)
10-0302	FRZ.1630.11	16	50	30	11	FDM 1714 D (M11x1,5)

Abmessungen in mm
Dimensions in mm

Hinweis/Note:

IK durch den Halter möglich.
coolant through the holder is possible

Ersatzteile / Spare parts

62.000.8

62.000.11

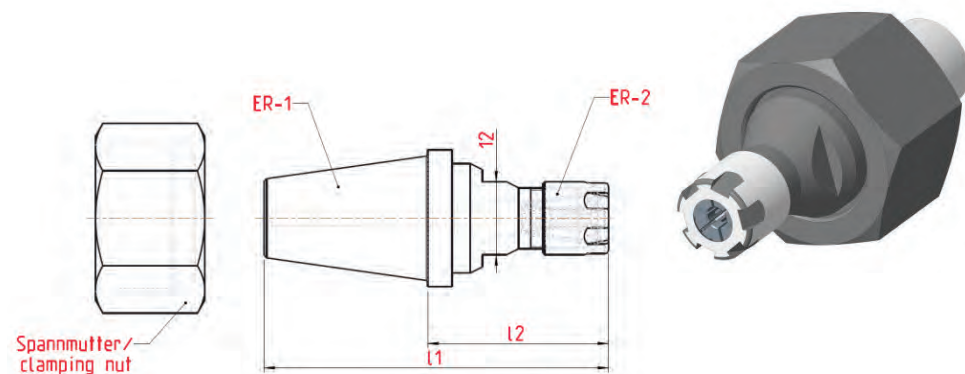
Fräsreduzierung ER20
Milling reduction ER20

Passend für alle ER20 Spannzangen Aufnahmen
Suitable for all ER20 chuck holder





Art der Spannmutter muss beim bestellen angegeben werden. Typ of the clamping nut must be specified when ordering.

Bestell Nummer Order Number	Bezeichnung Description	ER-1	I1	I2	ER-2	Spannmutter Clamping nut
10-0301	FRZ.2030.08	20	57	30	8	FDM 1736 B (M24x1) FDM 1736 C (M25x1,5)
10-0304	FRZ.2030.11	20	57	30	11	
10-0303	FRZ.2032.16	20	59	32	16	

Abmessungen in mm
Dimensions in mm

Hinweis/Note:

IK durch den Halter möglich.
coolant through the holder is possible

Ersatzteile / Spare parts		
ER8 	ER11 	ER16 
62.000.8	62.000.11	62.000.16

Rundschaft-Wendeplattenhalter Typ DC... Platte
Round shank turner plate holder type DC... insert

Rundschaft Ø 20
Round shank Ø 20

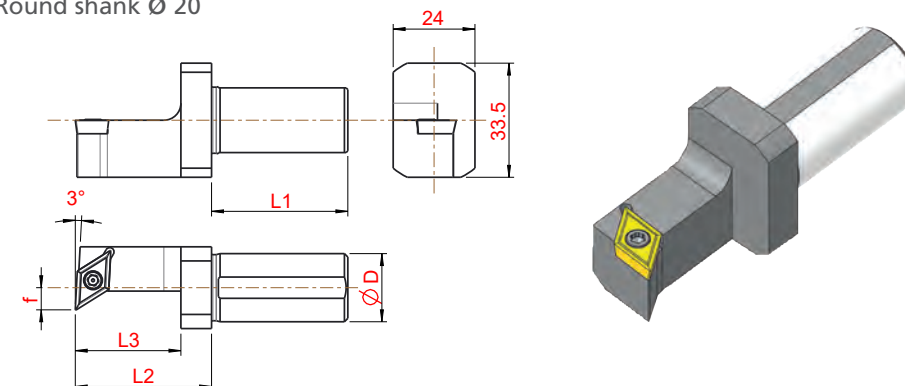

Ausführung linksschneidend, wie dargestellt · left cutting version as shown

Bestell Nummer Order Number	Bezeichnung Description	øD	I1	I2	I3	f	für Wendschneidplatte for cutting insert
01-1398	SDUC.R.2040.B11	20	40	40	31	6,5	DC... 11...
01-1399	SDUC.L.2040.B11	20	40	40	31	6,5	DC... 11...
01-1404	SDUC.R.2040.C11	20	40	50	40	6,5	DC... 11...
01-1405	SDUC.L.2040.C11	20	40	50	40	6,5	DC... 11...

Abmessungen in mm
Dimensions in mm

Hinweis/Note:

ohne IK
without IK

Ersatzteile / Spare parts

001.01.15

Rundschaft-Wendepplattenhalter Typ VC... Platte
Round shank turner plate holder type VC... insert

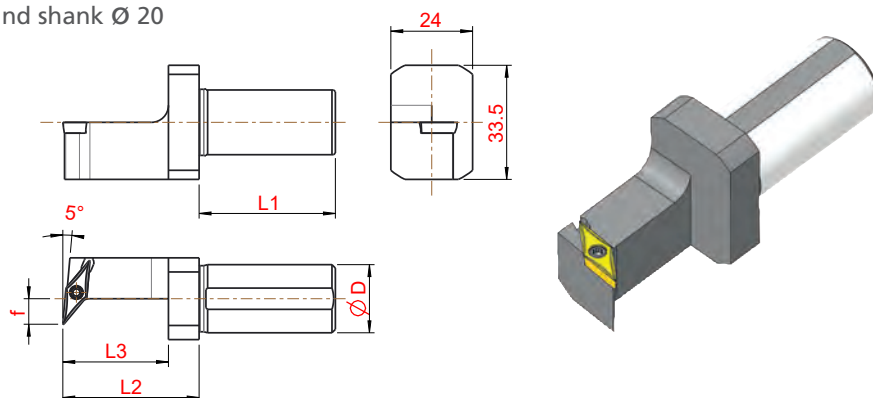
Rundschaft $\varnothing 20$
Round shank $\varnothing 20$



Ausführung linksschneidend, wie dargestellt · left cutting version as shown							
Bestell Nummer Order Number	Bezeichnung Description	$\varnothing D$	I1	I2	I3	f	für Wendeschneidplatte for cutting insert
01-1400	SVUC.R.2040.B11	20	40	40	31	7,5	VC... 11...
01-1401	SVUC.L.2040.B11	20	40	40	31	7,5	VC... 11...
01-1406	SVUC.R.2040.C11	20	40	50	40	7,5	VC... 11...
01-1407	SVUC.L.2040.C11	20	40	50	40	7,5	VC... 11...

Abmessungen in mm
Dimensions in mm

Hinweis/Note:
ohne IK
without IK

Ersatzteile / Spare parts

001.01.08

Rundschaft-Wendepplattenhalter Typ 16ER/16EL
Round shank turner plate holder type 16ER/16EL

Rundschaft $\varnothing 20$
Round shank $\varnothing 20$

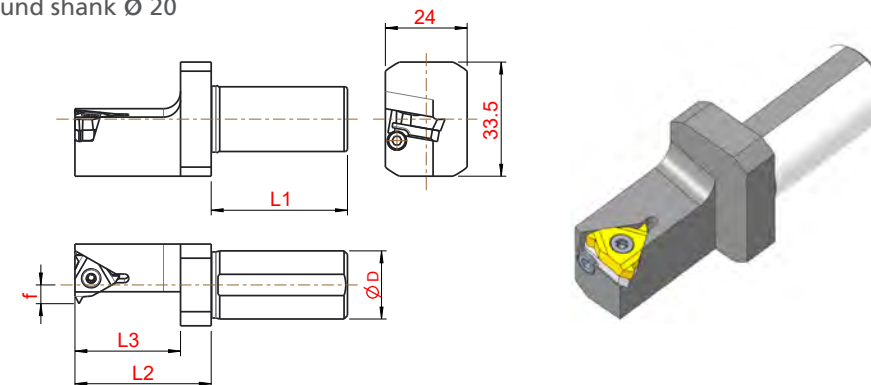

Ausführung linksschneidend, wie dargestellt · left cutting version as shown							
Bestell Nummer Order Number	Bezeichnung Description	$\varnothing D$	I1	I2	I3	f	für Wendeschneidplatte for cutting insert
01-1402	SER.2040.B16	20	40	40	31	5,5	16ER
01-1403	SEL.2040.B16	20	40	40	31	5,5	16EL
01-1408	SER.2040.C16	20	40	50	40	5,5	16ER
01-1409	SEL.2040.C16	20	40	50	40	5,5	16EL

Abmessungen in mm
Dimensions in mm

Hinweis/Note:
ohne IK
without IK

Ersatzteile / Spare parts

001.01.65

Unterlegplatte / Shim						
	3° N	2° N	1° N	0°	1° P	2° P
Art. Nr. R	00200185	00200184	00200183	00200180	00200182	00200181
Art. Nr. L	00200195	00200194	00200193	00200190	00200192	00200191

Berechnung
Steigungswinkel
Seite 4.82-4.83!

Rundschaft-Wendepplattenhalter Typ DC... Platte
Round shank turner plate holder type DC... insert

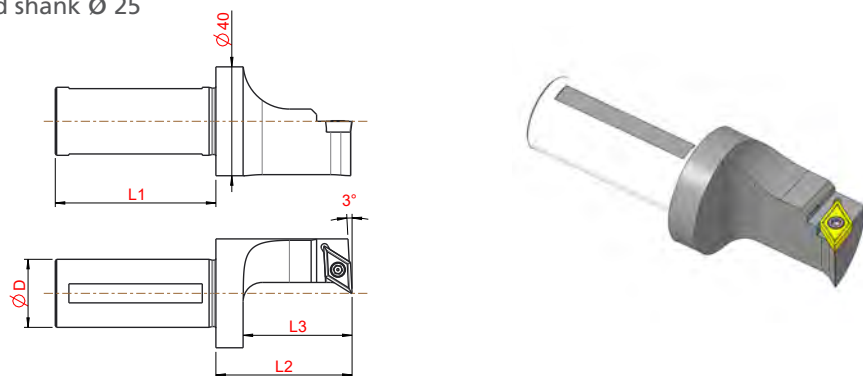
Rundschaft Ø 25
Round shank Ø 25



Ausführung rechtsschneidend, wie dargestellt · right cutting version as shown							
Bestell Nummer Order Number	Bezeichnung Description	øD	I1	I2	I3	f	für Wendeschneidplatte for cutting insert
01-1380	SDUC.R.2559.C11.IK	25	59	50	40	-	DC... 11...

Weitere Halter auf Anfrage
Additional holders on request

Abmessungen in mm
Dimensions in mm

Hinweis/Note:
IK durch den Schaft
IK through the shaft

Ersatzteile / Spare parts

001.01.15

Rundschaft-Wendepplattenhalter Typ DC... Platte
Round shank turner plate holder type DC... insert

Rundschaft Ø 25
Round shank Ø 25

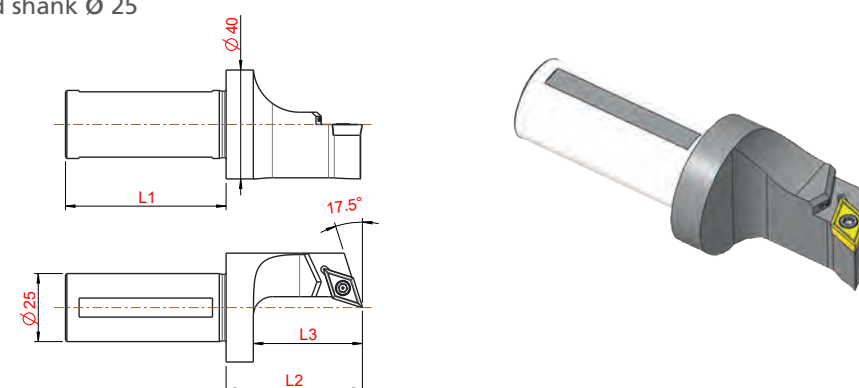

Ausführung rechtsschneidend, wie dargestellt · right cutting version as shown							
Bestell Nummer Order Number	Bezeichnung Description	øD	I1	I2	I3	f	für Wendeschneidplatte for cutting insert
01-1433	SDXC.R.2559.C11.IK	25	59	50	40	-	DC... 11...

Weitere Halter auf Anfrage
Additional holders on request

Abmessungen in mm
Dimensions in mm

Hinweis/Note:
IK durch den Schaft
IK through the shaft

Ersatzteile / Spare parts

001.01.15

Rundschaft-Wendepplattenhalter Typ DC... Platte
Round shank turner plate holder type DC... insert

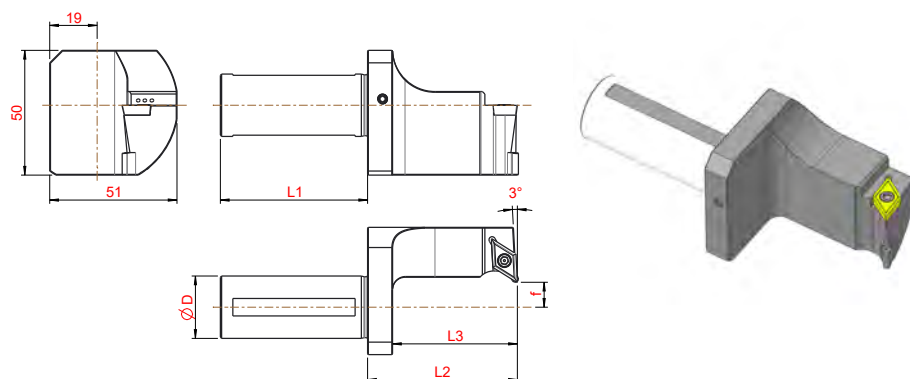
Rundschaft Ø 25
Round shank Ø 25



Ausführung rechtsschneidend, wie dargestellt · right cutting version as shown							
Bestell Nummer Order Number	Bezeichnung Description	ØD	I1	I2	I3	f	für Wendeschneidplatte for cutting insert
01-1372	SDUC.R.2559.C11.2IK	25	59	60	50	10	DC... 11...

Weitere Halter auf Anfrage
Additional holders on request

Abmessungen in mm
Dimensions in mm

4

Hinweis/Note:
IK durch den Schaft
IK through the shaft

Ersatzteile / Spare parts
001.01.15

Rundschaft-Wendepplattenhalter Typ VC... Platte
Round shank turner plate holder type VC... insert

Rundschaft Ø 25
Round shank Ø 25

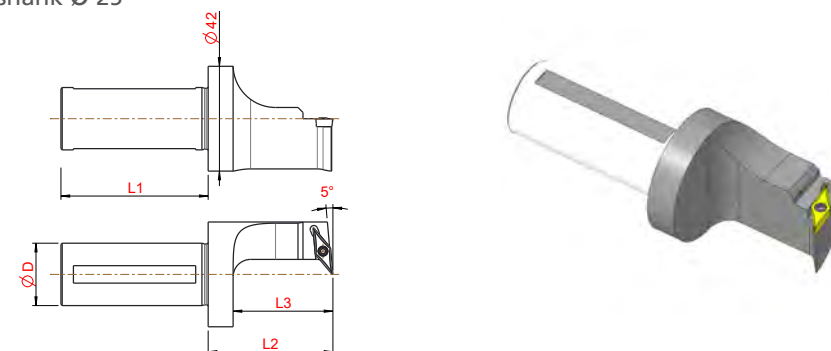

Ausführung rechtsschneidend, wie dargestellt · right cutting version as shown							
Bestell Nummer Order Number	Bezeichnung Description	ØD	I1	I2	I3	f	für Wendeschneidplatte for cutting insert
01-1382	SVUC.R.2559.C11.IK	25	59	50	40	-	VC... 11...

Weitere Halter auf Anfrage
Additional holders on request

Abmessungen in mm
Dimensions in mm

4

Hinweis/Note:
IK durch den Schaft
IK through the shaft

Ersatzteile / Spare parts
001.01.08

Rundschaft-Wendepplattenhalter Typ VC... Platte
Round shank turnet plate holder type VC... insert

Rundschaft Ø 25
Round shank Ø 25

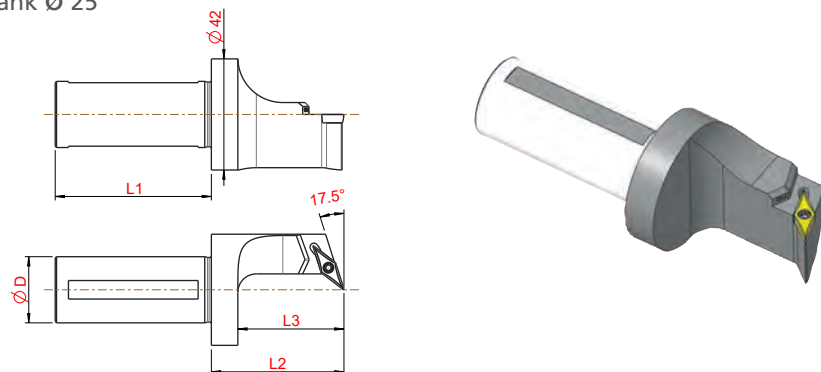

Ausführung rechtsschneidend, wie dargestellt · right cutting version as shown							
Bestell Nummer Order Number	Bezeichnung Description	ØD	I1	I2	I3	f	für Wendeschneidplatte for cutting insert
01-1432	SVXC.R.2559.C11.2IK	25	59	60	50	-	VC... 11...

Weitere Halter auf Anfrage
Additional holders on request

Abmessungen in mm
Dimensions in mm

4

Hinweis/Note:
IK durch den Schaft
IK through the shaft

Ersatzteile / Spare parts

001.01.08

Rundschaft-Wendepplattenhalter Typ VC... Platte
Round shank turnet plate holder type VC... insert

Rundschaft Ø 25
Round shank Ø 25

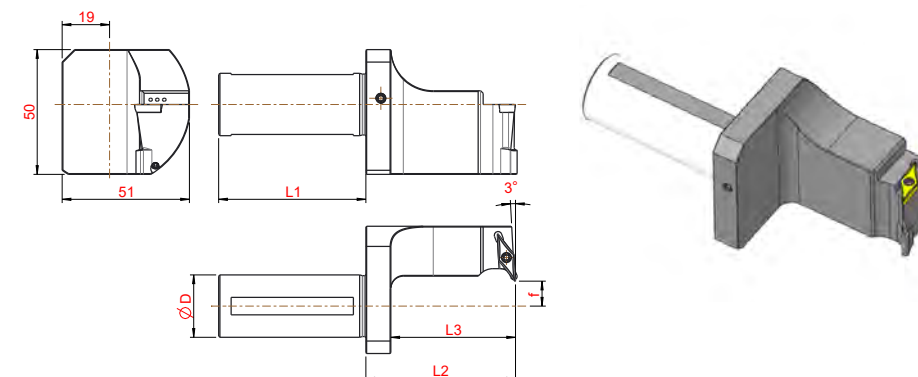

Ausführung rechtsschneidend, wie dargestellt · right cutting version as shown							
Bestell Nummer Order Number	Bezeichnung Description	ØD	I1	I2	I3	f	für Wendeschneidplatte for cutting insert
01-1373	SVUC.R.2559.C11.2IK	25	59	60	50	10	VC... 11...

Weitere Halter auf Anfrage
Additional holders on request

Abmessungen in mm
Dimensions in mm

4

Hinweis/Note:
IK durch den Schaft
IK through the shaft

Ersatzteile / Spare parts

001.01.08

Rundschaft-Wendepplattenhalter Typ 16ER/16EL
Round shank turnet plate holder type 16ER/16EL

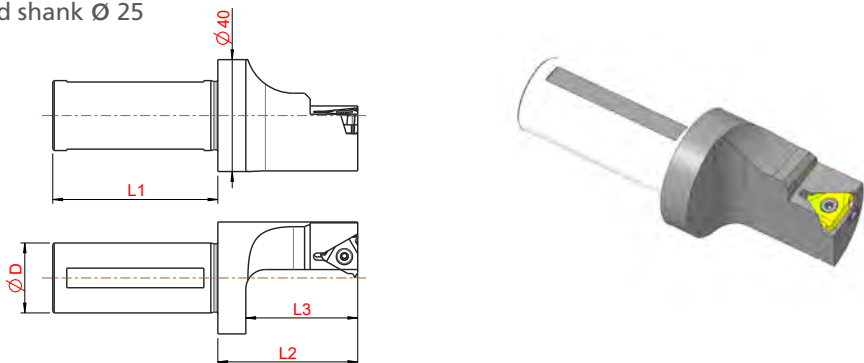
Rundschaft $\varnothing 25$
Round shank $\varnothing 25$



Ausführung rechtsschneidend, wie dargestellt · right cutting version as shown							
Bestell Nummer Order Number	Bezeichnung Description	$\varnothing D$	I1	I2	I3	f	für Wendeschneidplatte for cutting insert
01-1383	SER.2559.C16.IK	25	59	50	40	-	16ER

Weitere Halter auf Anfrage
Additional holders on request

Abmessungen in mm
Dimensions in mm

Hinweis/Note:
IK durch den Schaft
IK through the shaft

Ersatzteile / Spare parts

001.01.65

Unterlegplatte / Shim						
	3° N	2° N	1° N	0°	1° P	2° P
Art. Nr. R	00200185	00200184	00200183	00200180	00200182	00200181
Art. Nr. L	00200195	00200194	00200193	00200190	00200192	00200191

Berechnung Steigungswinkel
Seite 4.82 - 4.83!
Calculation helixangle see
page 4.82 - 4.83!

Rundschaft-Wendepplattenhalter Typ 16ER/16EL
Round shank turnet plate holder type 16ER/16EL

Rundschaft $\varnothing 25$
Round shank $\varnothing 25$

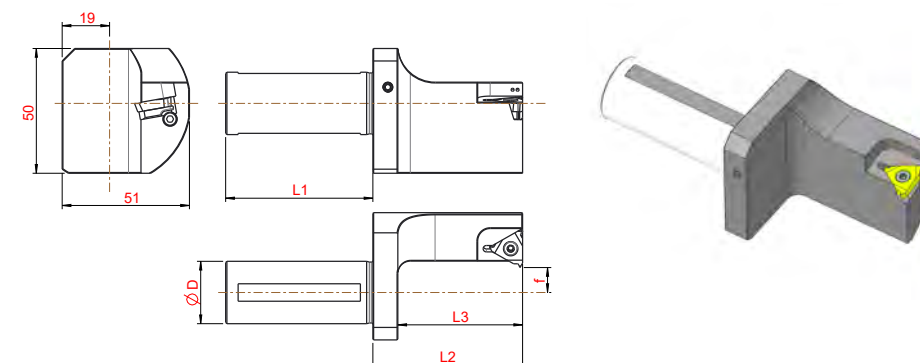

Ausführung rechtsschneidend, wie dargestellt · right cutting version as shown							
Bestell Nummer Order Number	Bezeichnung Description	$\varnothing D$	I1	I2	I3	f	für Wendeschneidplatte for cutting insert
01-1375	SER.2559.D16.IK	25	59	60	50	10	16ER

Weitere Halter auf Anfrage
Additional holders on request

Abmessungen in mm
Dimensions in mm

Hinweis/Note:
IK durch den Schaft
IK through the shaft

Ersatzteile / Spare parts

001.01.65

Unterlegplatte / Shim						
	3° N	2° N	1° N	0°	1° P	2° P
Art. Nr. R	00200185	00200184	00200183	00200180	00200182	00200181
Art. Nr. L	00200195	00200194	00200193	00200190	00200192	00200191

Berechnung Steigungswinkel
Seite 4.82 - 4.83!
Calculation helixangle see
page 4.82 - 4.83!

Rundschaft-Wendeplattenhalter Typ Horn 312
Round shank turnet plate holder type Horn 312

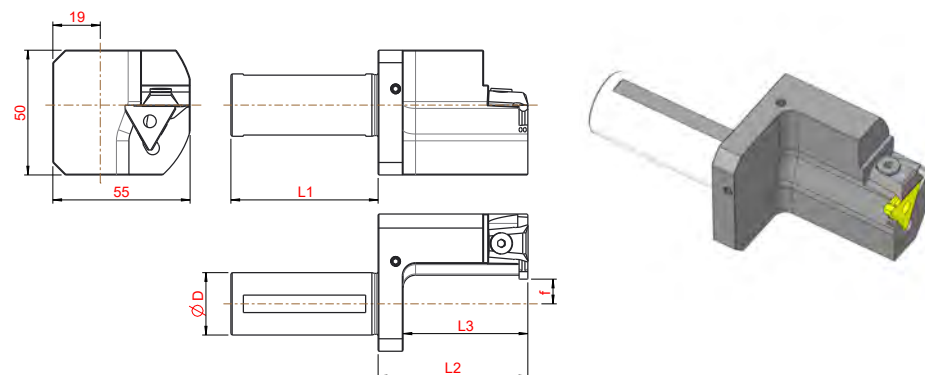
Rundschaft Ø 25
Round shank Ø 25



Ausführung linksschneidend, wie dargestellt · left cutting version as shown							
Bestell Nummer Order Number	Bezeichnung Description	ØD	l1	l2	l3	f	für Wendeplattenschnitt for cutting insert
01-1385	912.R.2559.D03.IK	25	59	60	50	10	Horn Typ 312/03
01-1384	912.R.2559.D04.IK	25	59	60	50	10	Horn Typ 312/04

Abmessungen in mm
Dimensions in mm

Weitere Halter auf Anfrage
Additional holders on request

Hinweis/Note:
IK durch den Schaft
IK through the shaft

Ersatzteile / Spare parts

001.01.81

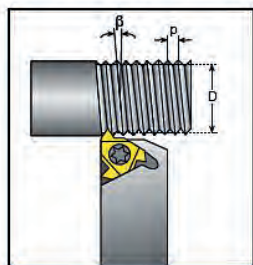
Berechnung des Steigungswinkel β



Der Steigungswinkel wird mit folgender Formel berechnet:

$$\beta = \arctan \frac{P \times N}{\pi \times D}$$

β - Steigungswinkel [°]
 P - Teilung [mm]
 N - Anzahl der Gänge
 D - Flankendurchmesser [mm]
 Steigung L = P x N

Der Steigungswinkel kann ebenfalls aus dem untenstehenden Diagramm abgelesen werden.

Calculating the Helix Angle β

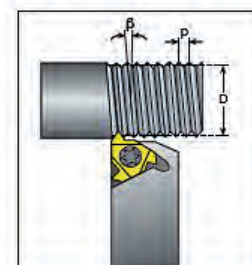

The helix angle is calculated by the following formula:

$$\beta = \arctan \frac{P \times N}{\pi \times D}$$

β - Helix angle [°]
 P - Pitch [mm]
 N - No. of starts
 D - Pitch diameter [mm]
 Lead = P x N

The helix angle can also be found from the diagram below.

Steigungswinkeldiagramm

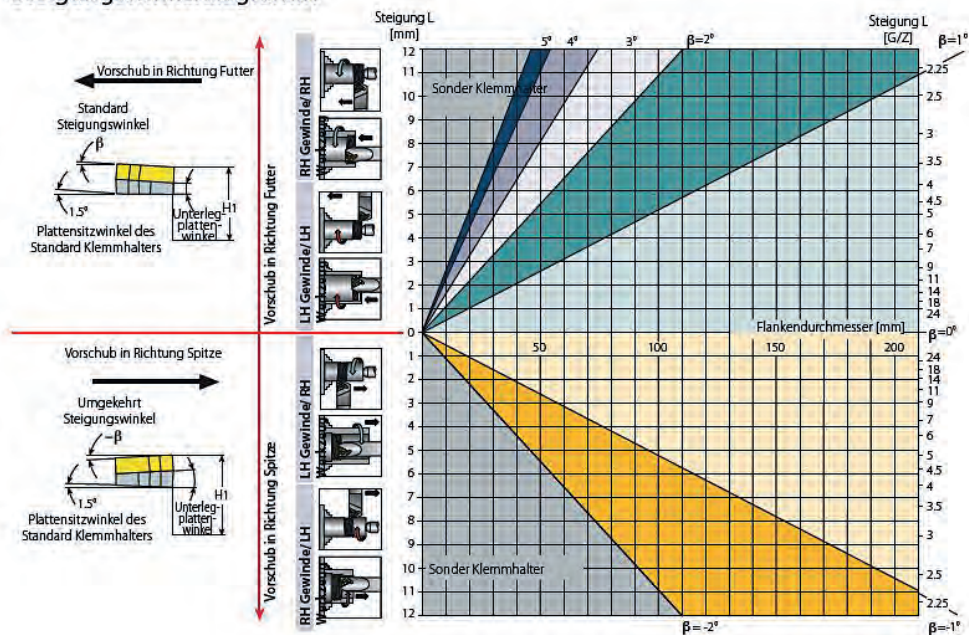

Helix Angle Diagram

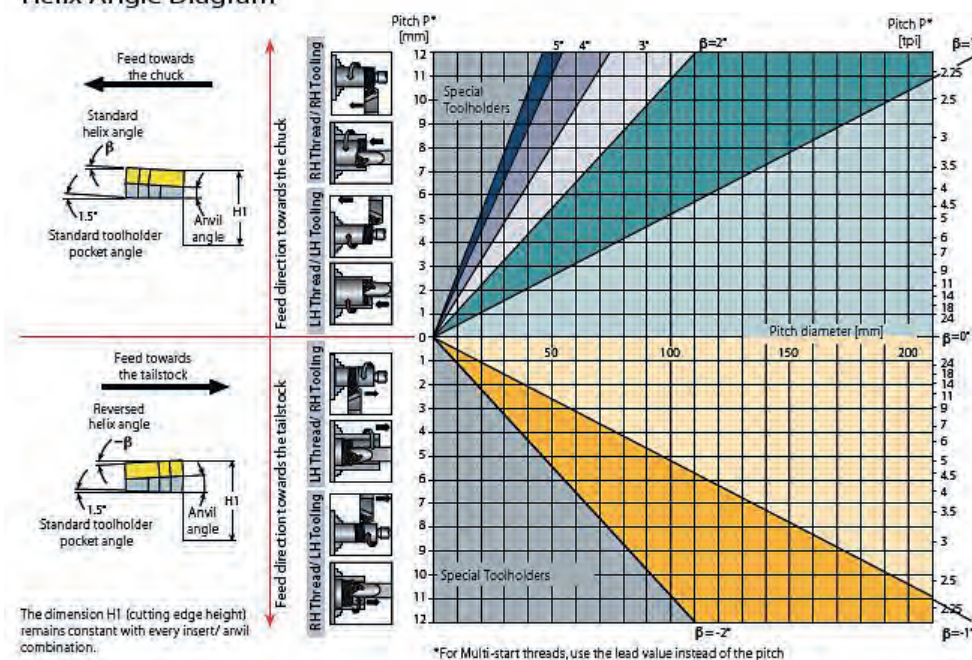

The dimension H1 (cutting edge height) remains constant with every insert/ anvil combination.

*For Multi-start threads, use the lead value instead of the pitch

Resultierender Steigungswinkel	4,5°	3,5°	2,5°	1,5°	0,5°	0°	-0,5°	-1,5°
Plattensitzwinkel	3°P	2°P	1°P	0°	1°N	1,5°N	2°N	3°N
Artikelnummer R	002.00.186	002.00.181	002.00.182	002.00.180	002.00.183	002.00.187	002.00.184	002.00.185
Artikelnummer L	002.00.196	002.00.191	002.00.192	002.00.190	002.00.193	002.00.197	002.00.194	002.00.195

resultant pitch angle	4,5°	3,5°	2,5°	1,5°	0,5°	0°	-0,5°	-1,5°
shim angle	3°P	2°P	1°P	0°	1°N	1,5°N	2°N	3°N
article number R	002.00.186	002.00.181	002.00.182	002.00.180	002.00.183	002.00.187	002.00.184	002.00.185
article number L	002.00.196	002.00.191	002.00.192	002.00.190	002.00.193	002.00.197	002.00.194	002.00.195

INHALTSVERZEICHNIS
SUMMARY

Flexible Leitungen Flexible Tubes	5.2
Kühlmittelanschlüsse Coolant Connections	5.3
Schnellkupplungen Quick Couplings	5.4
Verteilerleiste Distributor Blocks	5.7

Flexible Leitungen
Flexible tubes

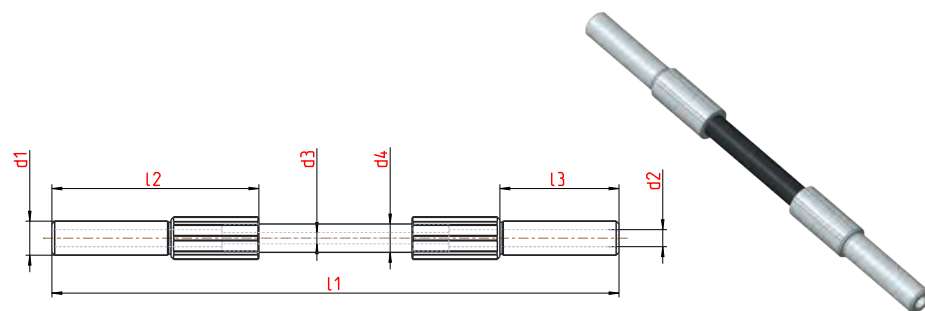

Bestellnummer Part number	l1	l2	l3	d1	d2	d3	d4	max. Druck [bar] max. pressure [bar]
21-1109	100	36,5	21	6	1,5	3	6	250
21-1111	150	36,5	21	6	1,5	3	6	250
21-1112	200	36,5	21	6	1,5	3	6	250
21-1113	250	36,5	21	6	1,5	3	6	250
21-1114	300	36,5	21	6	1,5	3	6	250
21-1115	400	36,5	21	6	1,5	3	6	250
21-1116	500	36,5	21	6	1,5	3	6	250
21-1159	200	57	20	6	2,5	5	10	250
21-1160	250	57	20	6	2,5	5	10	250
21-1161	300	57	20	6	2,5	5	10	250
21-1162	400	57	20	6	2,5	5	10	250
21-1163	500	57	20	6	2,5	5	10	250

Abmessungen in mm
Dimensions in mm

Hinweis / Note:
Weitere Längen auf Anfrage
d3 = Innendurchmesser der Leitung
other lengths on request
d3 = internal diameter of the tube

Kühlmittelanschlüsse
Coolant connections

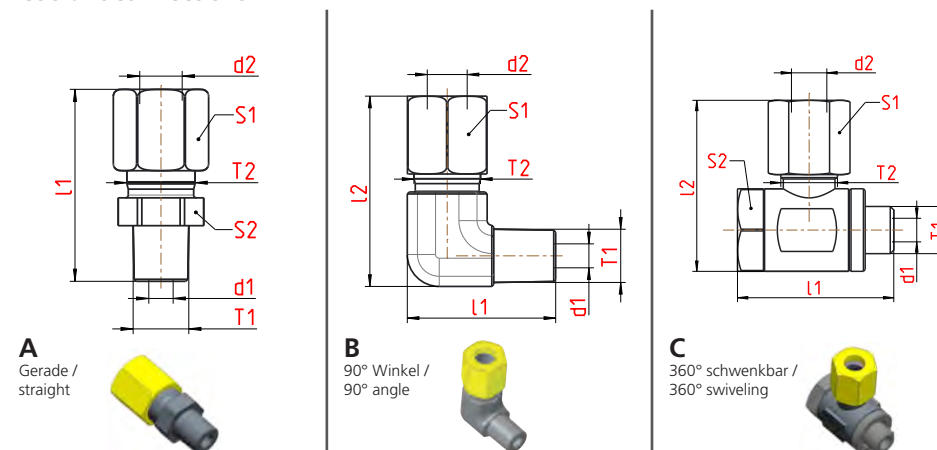

Ausführung Design	Bestellnummer Part number	l1	l2	d1	d2	T1	T2	S1	S2
A	004.00.14	33,7	-	4	6	G1/8" keg.	M12x1,5	SW14	SW14
A	004.00.19	28	-	3,5	6	M8x1 keg.	M10x1	SW12	SW11
A	004.00.36	27,5	-	2	4	M6x1 keg.	M8x1	SW10	SW9
A	004.00.15	41,5	-	7	10	G1/4" keg.	M16	SW19	SW17
B	004.00.22	22,4	28,2	3,6	6	M8x1 keg.	M10x1	SW12	-
B	004.00.33	26,6	35,6	4,5	6	G1/8" keg.	M12x1,5	SW14	-
B	004.00.34	38,9	33,6	7	10	G1/4" keg.	M16	SW19	-
B	004.00.37	22,3	27,6	2	4	M6x1 keg.	M8x1	SW10	-
C	004.00.61	26,5	29	4	6	M8x1	M12x1,5	SW12	SW14
C	004.00.16	26,5	29	4	6	G1/8"	M12x1,5	SW12	SW14
C	004.00.47	36,7	43,2	6,5	6	G1/4"	M14	SW17	SW19
C	004.00.18	36,7	43,2	6,5	10	G1/4"	M16	SW19	SW19
C	004.00.84	42	46	6	6	M12x1,5	M14x1,5	SW17	SW19
C	004.00.77	24,5	27	2,5	6	M5	M10x1	SW12	SW10

Abmessungen in mm
Dimensions in mm

Hinweis / Note:
Ausführung A und B Druckbeständig bis 100 bar, Ausführung C bis 250 bar
d2 = Klemmdurchmesser für Flex-Leitungen // T1 = keg. = Kegelgewinde
Design A and B pressure up to 100 bar, Design C up to 250 bar
d2 = clamp diameter for flexible tubes // T1 = keg. = tapered thread

Verschlussstopfen
Sealing plug

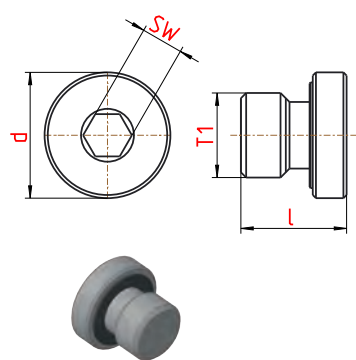

Schnellkupplungen
Quick couplings

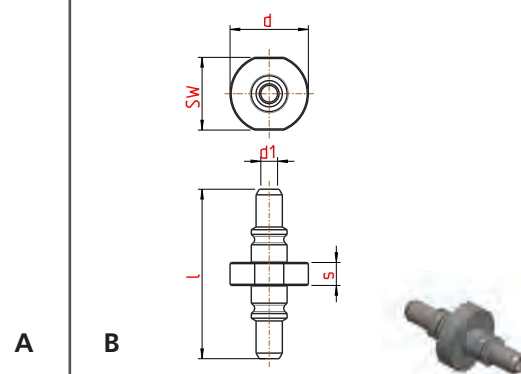

Produkt product	Bestellnummer Part number	l	s	d	d1	T1	SW
A	004.00.21	10	-	12	-	M8x1	4
A	004.00.26	12	-	14	-	G1/8"	5
A	004.00.27	12	-	20	-	G1/4"	6
A	004.00.30	17	-	22	-	G3/8"	8
B	Doppelstecker / double plug						
B	004.00.74	30	4	14	3	-	13

Abmessungen in mm
Dimensions in mm

Hinweis / Note:

Weitere Größen und Ausführungen auf Anfrage
other sizes and designs on request

Schnellkupplungen
Quick couplings

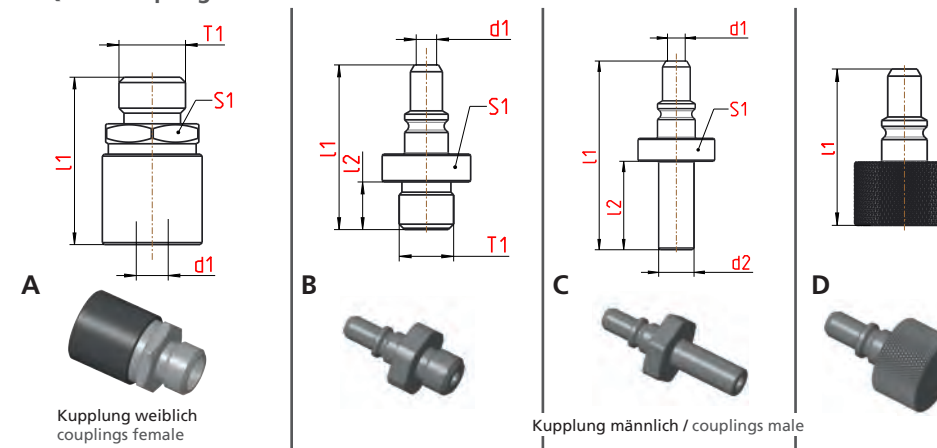

Ausführung Design	Bestellnummer Part number	l1	l2	d1	d2	T1	S1
A	Kupplung / couplings						
A *1 *2	004.00.49	25	-	4,9	-	M10x1	SW14
A	004.00.71	25	-	4,9	-	G1/8"	SW14
A	004.00.73	25	-	4,9	-	M8x1	SW14
B	Schraubanschluss / screw connection						
B	004.00.56	24,25	7	3	-	M8x1	SW13
B	004.00.57	24,25	7	3	-	G1/8"	SW13
B	004.00.58	24,25	7	3	-	G1/4"	SW17
B *1	004.00.63	24,25	7	3	-	M10x1	SW13
B *1 *2	004.00.63-1	24,25	7	3	-	M10x1	SW13
C	Klemmverbindung / clamp connection						
C	004.00.59	32	15	3	6	-	SW13
D	Verschlussstopfen / Sealing plug						
D	004.00.66	22	-	-	-	-	-

Abmessungen in mm
Dimensions in mm

Hinweis / Note:

Druckbeständig bis 100bar - weitere Größen und Ausführungen der männlichen Kupplungen auf Anfrage

*1 = Klemmmöglichkeit für Flex-Leitungen gegeben

*2 = inkl. Überwurfmutter und Schneidring

pressure up to 100 bar - other sizes and designs of the male couplings on request

*1 = terminal opportunity for flex lines given

*2 = incl. union nut and olive

Schnellkupplungen
Quick couplings

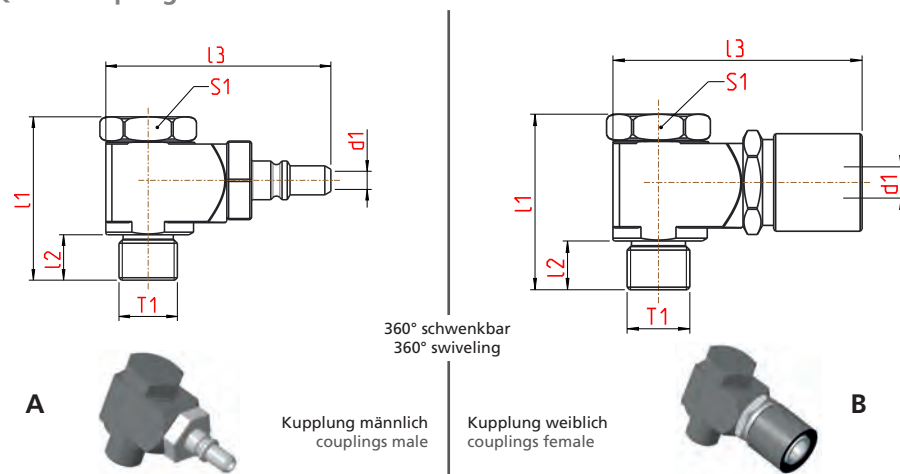

Ausführung Design	Bestellnummer Part number	l1	l2	l3	d1	T1	S1
A	männlich/male						
A	004.00.52	27	7,5	37	3	G1/8"	SW14
A	004.00.53	27	7,5	37	3	M8x1	SW14
B	weiblich/female						
B	004.00.80	27	7,5	38	4,8	G1/8"	SW14
B	004.00.81	27	7,5	38	4,8	M8x1	SW14

Abmessungen in mm
Dimensions in mm

Hinweis / Note:
Weitere Größen und Ausführungen auf Anfrage
other sizes and designs on request

Verteilerleisten
Distributor blocks

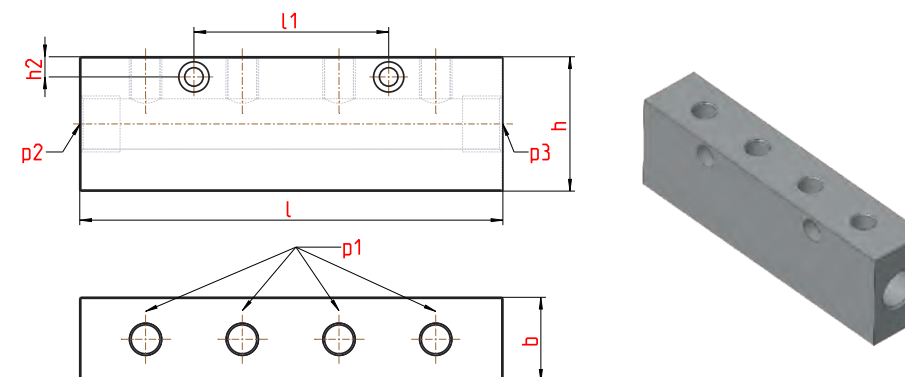

Bestellnummer Part number	l	l1	b	h	h2	Anzahl number	p1 Art type	p2	p3
21-4207	66	-	25	40	6	2	M8x1	G3/8"	G3/8"
21-4208	66	-	25	40	6	2	G1/8"	G3/8"	G3/8"
21-4209	96	28	25	40	6	3	M8x1	G3/8"	G3/8"
21-4210	96	28	25	40	6	3	G1/8"	G3/8"	G3/8"
21-4211	126	58	25	40	6	4	M8x1	G3/8"	G3/8"
21-4212	126	58	25	40	6	4	G1/8"	G3/8"	G3/8"
21-4213	186	118	25	40	6	6	M8x1	G3/8"	G3/8"
21-4214	186	118	25	40	6	6	G1/8"	G3/8"	G3/8"

Abmessungen in mm
Dimensions in mm

Hinweis / Note:
Weitere Größen und Ausführungen auf Anfrage
other sizes and designs on request

Verbindungsbeispiel
Connection example

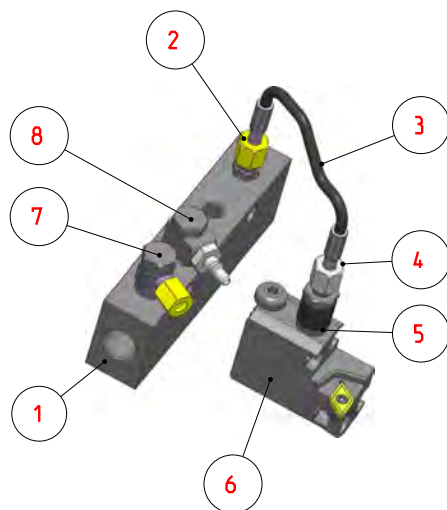

Pos.	Bauteil Part	Bestellnummer Part number	Broschürenseite booklets page
1	Verteilerleiste distributor block	21-4211	8
2	Kühlmittelanschluss coolant connection	004.00.19	4
3	Flex-Leitung flexible tube	21-1114	3
4	Schnellkupplung, weiblich quick coupling, female	004.00.49	6
5	Kupplung, männlich coupling, male	004.00.63	6
6	Rückseitenhalter, höhenverstellbar back holder, adjustable	R84.TN16.IK	-
7	Kühlmittelanschluss coolant connection	004.00.61	4
8	Schnellkupplung, männlich quick coupling, male	004.00.53	7

Hinweis / Note:

Bei Fragen und Verbindungsproblemen beraten wir Sie gerne
For questions and connection problems, we will be happy to advise you.

FEBAMETAL

www.febametal.com

Febametal S.p.A.
Via Grandi 15, 10095 Grugliasco (TO)

 011-7701412

 febametal@febametal.com