

**ph HORN ph**



**SUPERMINI ET MINI  
USINAGE INTÉRIEUR**

**SUPERMINI E MINI  
LAVORAZIONI INTERNE**

**2025/2026**





**EXPÉRIMENTEZ HORN**  
**PROVA HORN**

## Expérimentez HORN

Des résultats remarquables sont toujours la combinaison d'un processus d'usinage optimisé et d'un outil parfaitement adapté. Pour cela, HORN allie technologie de pointe, performance et fiabilité. De la pièce unitaire à la production en série, pour des applications standard ou spéciales: Nos outils vous offrent des solutions à la fois rapides, économiques et de grande qualité. Lors du choix des paramètres de coupe spécifiques, nos tableaux dans les catalogues correspondants sont avec des valeurs de référence basées sur la pratique vous aideront dans chaque catalogue.

Profitez également du savoir-faire de nos équipes en interne et de nos ingénieurs des ventes. La durabilité est un élément central de notre philosophie d'entreprise. C'est pourquoi l'assurance qualité, la protection de l'environnement, l'efficacité énergétique et la sécurité de nos produits et de notre production sont depuis toujours au cœur de nos préoccupations. En tant que partenaire en outillage performant et à la fiabilité reconnue, nous veillons à ce que vous vous engagiez avec nous dans un avenir innovant et économique.

Visitez également notre eShop, disponible 24 heures sur 24.



Markus Horn  
Directeur Général  
Paul Horn GmbH



Matthias Rommel  
Directeur Général  
Paul Horn GmbH

## Prova HORN

Per ottenere risultati eccellenti, è fondamentale combinare un processo di taglio ottimale con l'utensile giusto. HORN rende possibile tutto questo grazie a tecnologia avanzata, alte prestazioni e massima affidabilità.

Che si tratti di pezzi singoli o di produzione in serie, per applicazioni standard o speciali, i nostri utensili garantiscono soluzioni rapide, economiche e di alta qualità. Per aiutarti nella scelta dei parametri di taglio, nei nostri cataloghi troverai tabelle con valori testati e affidabili. Inoltre, il nostro team tecnico e i nostri ingegneri commerciali sono sempre a disposizione per offrirti supporto.

La sostenibilità è un valore chiave per HORN. Ci impegniamo da sempre nella qualità, nella protezione dell'ambiente, nell'efficienza energetica e nella sicurezza, sia nei prodotti che nei processi produttivi. Il nostro obiettivo è accompagnarti verso un futuro innovativo e competitivo. Metti alla prova HORN!



Markus Horn  
Direttore Generale  
Paul Horn GmbH



Matthias Rommel  
Direttore Generale  
Paul Horn GmbH







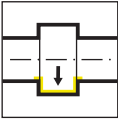
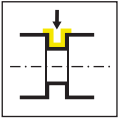
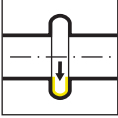
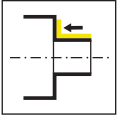
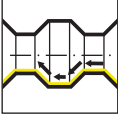

- A Supermini Système / Sistema 105**  
Alésage, Gorge, Chanfreinage, Filetage, Gorge frontale  
Alesatura, Gole, Smussatura, Filettatura, Gole assiali
- B Supermini Système / Sistema 109**  
Alésage, Gorge, Chanfreinage, Filetage, Gorge frontale  
Alesatura, Gole, Smussatura, Filettatura, Gole assiali
- C Supermini Système / Sistema 110**  
Alésage, Gorge, Gorge frontale  
Alesatura, Gole, Gole assiali
- D Mini Système / Sistema 106**  
Alésage, Gorge, Chanfreinage  
Alesatura, Gole, Smussatura
- E Mini Système / Sistema 107**  
Alésage, Gorge, Chanfreinage, Filetage  
Alesatura, Gole, Smussatura, Filettatura
- F Mini Système / Sistema 108**  
Alésage, Gorge, Chanfreinage, Filetage  
Alesatura, Gole, Smussatura, Filettatura
- G Mini Système / Sistema 10P**  
Alésage, Gorge  
Alesatura, Gole
- H Mini Système / Sistema 111**  
Alésage, Gorge, Chanfreinage, Filetage  
Alesatura, Gole, Smussatura, Filettatura
- I Mini Système / Sistema 11P**  
Alésage, Gorge  
Alesatura, Gole
- J Mini Système / Sistema 114**  
Alésage, Gorge, Chanfreinage, Filetage, Gorge frontale  
Alesatura, Gole, Smussatura, Filettatura, Gole assiali
- K Mini Système / Sistema 116**  
Alésage, Gorge, Chanfreinage, Filetage  
Alesatura, Gole, Smussatura, Filettatura
- L Mini Système / Sistema 18P**  
Alésage, Gorge  
Alesatura, Gole
- M Informations techniques, Exemple d'usinage, Accessoires**  
Dati tecnici, Esempi di lavorazione, Accessori
- INDEX**

**A****B****C****D****E****F****G****H****I****J****K****L****M**

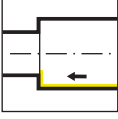
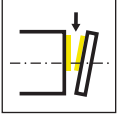
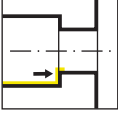
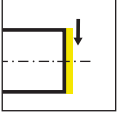
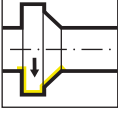
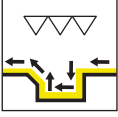
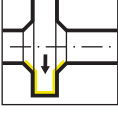
# Vue d'ensemble des applications

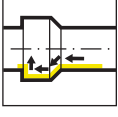
## Panoramica delle applicazioni

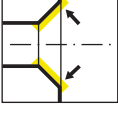
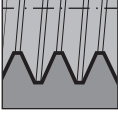
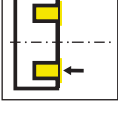
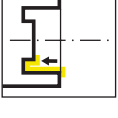
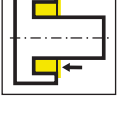









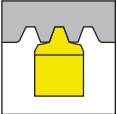
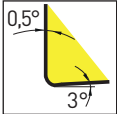
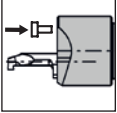
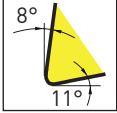
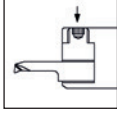
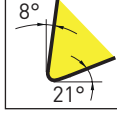
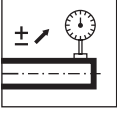
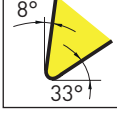

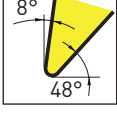

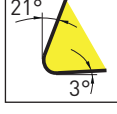

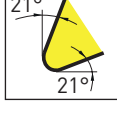

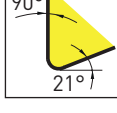
	Gorge intérieure Gole interne		Gorge extérieure Gole esterne
	Gorge intérieure à rayon complet Gole interne tutto raggio		Chariotage extérieur Tornitura in passata esterna
	Alésage et chanfrein intérieur Barenatura interna e smussatura		Copiage et chariotage extérieur Tornitura in copiatura esterna
	Alésage intérieur Barenatura interna		Tronçonnage Troncatura
	Tournage en tirant intérieur Alésatura in tiro interna		Dressage de face Sfacciatura
	Pretronçonnage et chanfreinage intérieur Pregola e smussatura interna		Tournage de précision Tornitura fine
	Gorge intérieure avec chanfrein Gole con smussi		Filetage profil partiel Profilo parziale del filo
	Alésage et copiage Barenatura e profilatura		Filetage profil plein Profilo completo del filo
	Chanfreinage intérieur Smussatura interna		Filetage intérieur Filettatura interna
	Gorge frontale Gole assiali	<b>BSW BSF</b>	Filetage Whitworth BSW/BSF Filettatura Whitworth BSW/BSF
	Gorge frontale dans un alésage Gole assiali interne	<b>NPT NPTF</b>	National pipe thread
	Gorge frontale le long d'un axe Gole assiali con ingombro	<b>60°</b>	Filetage ISO-métrique Filettatura ISO-Metrica
	Perçage dans le plein Foratura in materiale solido	<b>UN</b>	Filetage UN Filettatura UN

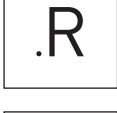
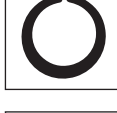
# Vue d'ensemble des applications

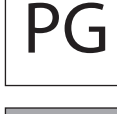
Panoramica delle applicazioni



	Filetage trapézoïdale Filettatura Trapezoidale		Angle de coupe Angolo di taglio
	Serrage de face Serraggio frontale		Angle de coupe Angolo di taglio
	Élément d'extraction Elemento di estrazione		Angle de coupe Angolo di taglio
	Réglage Pre-Setting		Angle de coupe Angolo di taglio
	Géométrie D Geometria D		Angle de coupe Angolo di taglio
	Géométrie FB Geometria FB		Angle de coupe Angolo di taglio
	Géométrie H Geometria H		Angle de coupe Angolo di taglio
	Géométrie HV Geometria HV		Angle de coupe Angolo di taglio
	Géométrie I Geometria I		L'usinage fin Lavorazione fine
	Géométrie R Geometria R		Gorges circlips Gole Seeger
	Géométrie GM - Filetage Geometria GM - Filettatura		Filetage profil PG Filetto profilo PG
	Géométrie U Geometria U		Usinage dur Alesatura di acciai trattati
	Arrosage intérieur Refrigerante interno		

# Géométries et avances - Supermini

Geometrie e avanzamenti - Supermini



Géométrie Geometria	Matière Materiale	Avance f [mm/rot.] Avanzamento f [mm/rev]	Usinage Lavorazione						
	<table border="1"> <tr><td>P</td><td>M</td><td>K</td></tr> <tr><td>N</td><td>S</td><td>H</td></tr> </table>	P	M	K	N	S	H	<p>←</p> <p><math>f = 0,04-0,06</math> <math>ap = 0,15-0,5 \text{ mm}</math></p>	
P	M	K							
N	S	H							
	<table border="1"> <tr><td>P</td><td>M</td><td>K</td></tr> <tr><td>N</td><td>S</td><td>H</td></tr> </table>	P	M	K	N	S	H	<p>←</p> <p><math>f = 0,05-0,1</math> <math>ap = 0,15-0,5 \text{ mm}</math></p>	
P	M	K							
N	S	H							
	<table border="1"> <tr><td>P</td><td>M</td><td>K</td></tr> <tr><td>N</td><td>S</td><td>H</td></tr> </table>	P	M	K	N	S	H	<p>↓</p> <p>↔</p> <p><math>f = 0,01-0,04</math> <math>ap = 0,03-0,05 \text{ mm}</math></p>	
P	M	K							
N	S	H							
	<table border="1"> <tr><td>P</td><td>M</td><td>K</td></tr> <tr><td>N</td><td>S</td><td>H</td></tr> </table>	P	M	K	N	S	H	<p>←</p> <p><math>f = 0,003-0,04</math> <math>ap = 0,005-0,1 \text{ mm}</math></p>	
P	M	K							
N	S	H							
	<table border="1"> <tr><td>P</td><td>M</td><td>K</td></tr> <tr><td>N</td><td>S</td><td>H</td></tr> </table>	P	M	K	N	S	H	<p>←</p> <p><math>f = 0,03-0,07</math> <math>ap = 0,1-0,4 \text{ mm}</math></p>	
P	M	K							
N	S	H							

Avance f [mm/rot.]

Avanzamento f [mm/rev]

$f = 0,01-0,03$

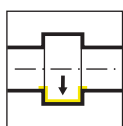

Gorge  
Gole

$f = 0,02-0,05$

$ap = 0,15-0,5 \text{ mm}$

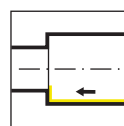

Chariotage  
Tornitura in passata

$f = 0,02-0,05$

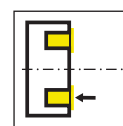

Gorge frontale  
Gole assiali

# Géométries et avances - Mini

Geometrie e avanzamenti - Mini



Géométrie Geometria	Matière Materiale	Avance f [mm/rot.] Avanzamento f [mm/rev]	Usinage Lavorazione						
	<table border="1"> <tr> <td>P</td> <td>M</td> <td>K</td> </tr> <tr> <td>N</td> <td>S</td> <td>H</td> </tr> </table>	P	M	K	N	S	H	<p>↓ <math>f = 0,03-0,08</math></p> <p>↔ <math>ap = 0,2-1,5^*</math></p>	
P	M	K							
N	S	H							
	<table border="1"> <tr> <td>P</td> <td>M</td> <td>K</td> </tr> <tr> <td>N</td> <td>S</td> <td>H</td> </tr> </table>	P	M	K	N	S	H	<p>↓ <math>f = 0,015-0,05</math></p> <p>↔ <math>ap = 0,03-0,07^*</math></p>	
P	M	K							
N	S	H							
	<table border="1"> <tr> <td>P</td> <td>M</td> <td>K</td> </tr> <tr> <td>N</td> <td>S</td> <td>H</td> </tr> </table>	P	M	K	N	S	H	<p>← <math>f = 0,05-0,15</math></p> <p><math>ap = 0,05-0,6</math></p>	
P	M	K							
N	S	H							
	<table border="1"> <tr> <td>P</td> <td>M</td> <td>K</td> </tr> <tr> <td>N</td> <td>S</td> <td>H</td> </tr> </table>	P	M	K	N	S	H	<p>← <math>f = 0,05-0,15</math></p> <p><math>ap = 0,2-2,0^*</math></p>	
P	M	K							
N	S	H							

\*En fonction du système / Dipendente dal sistema

Avance f [mm/rot.]

Avanzamento f [mm/rev]

$f = 0,01-0,05$

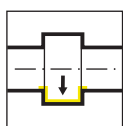

Gorge  
Gole

$f = 0,03-0,1$

$ap = 0,1-0,5 \text{ mm}$

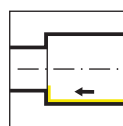

Chariotage  
Tornitura in passata

$f = 0,02-0,08$

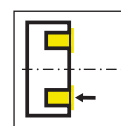

Gorge frontale  
Gole assiali

- Toutes les dimensions sont en mm, sauf indication contraire.  
Tutte le dimensioni sono espresse in mm, salvo diversa indicazione.
- D'autres dimensions et versions sont disponibles sur demande.  
Altre dimensioni e versioni sono disponibili su richiesta.
- Vous trouverez le couple de serrage des vis dans le chapitre " Instructions techniques ".  
Per le coppie di serraggio specifiche, consultare le "Istruzioni tecniche".
- Tous les porte-outils des systèmes "Mini" dont le support est endommagé peuvent être réparés par HORN.  
Tutti i portautensili dei sistemi "Mini" con sede danneggiata possono essere riparati da HORN.
- Délais de livraison / Tempo di consegna  
en stock / a stock  
Δ 4 semaines / 4 settimane
- Utilisation pour les groupes de matériaux / Utilizzo per gruppi di materiali
  - Premier choix / raccomandato
  - Choix alternatif / alternativa
  - ne convient pas / non adatto

### Le code d'interface de connexion HORN - à quoi sert-il ?

Le code de l'interface de connexion vous permet de toujours trouver les outils appropriés. Il est indiqué sur les porte-outils et les plaquettes. Si les codes correspondent, la plaquette peut être utilisée dans le porte-outil correspondant.

Cela s'applique également à notre système de porte-outils modulaire, où le code de connexion indique l'interface entre le porte-outils et la cassette.

### Il nuovo codice di accoppiamento HORN: a cosa serve?

Il codice di connessione assicura di utilizzare sempre il giusto utensile per ogni portautensile ed è riportato sia sui portautensili che sugli inserti. Se i codici corrispondono, l'inserto può essere utilizzato nel portautensile corrispondente.

Questo vale anche per il nostro sistema di portautensili modulari, dove il codice di connessione indica l'interfaccia tra il portautensile e la cassetta.

### Codes d'interface HORN et combinaisons possibles:

Codice di connessione HORN e possibili combinazioni:

**HIS** = Taille de logement de la plaquette / sede dell'inserto

**HWS** = Interface côté pièce / interfaccia dal lato del pezzo da lavorare

**HMS** = Interface côté machine / interfaccia dal lato della macchina

<b>HIS</b>	↔	<b>HWS</b>
<b>HMS</b>	↔	<b>HWS</b>

### Exemple de plaquette

Esempio di inserto

N° de commande Codice prodotto	r	f	a	d	l <sub>2</sub>	l <sub>5</sub>	t <sub>max</sub>	D <sub>min</sub>	HIS	TH35
<b>R109.1828.1.6</b>	0,2	2,8	5,7	5	10	28	0,4	6	109140	Δ

### Exemple de porte outils

Esempio di portainsero

N° de commande Codice prodotto	d	l <sub>1</sub>	h	l <sub>4</sub>	l <sub>2</sub>	d <sub>2</sub>	HWS
<b>B109.0012.01</b>	12	75	10	50	16	20	109140

**105**



**Porte outils et plaquettes**

**Portainserito e inserti**

Porte outils  
Portainsero

B105/BU105/H105/  
HC105/962/963/  
AIH/HF.N/HSKT40/  
VDI/B105C/B105TS/  
WFB.105

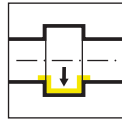

Page/Pag.  
15-17, 23, 26-31,  
34-41, 65-73, 75,  
135-137

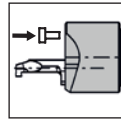

Page/Pag.  
19-22

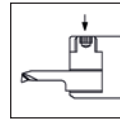

Page/Pag.  
25

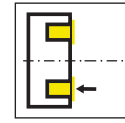

Page/Pag.  
146

Panoramica  
Vista d'insieme

Page/Pag.  
18, 24

Base de support Graf  
Supporto base Graf  
IR105/G

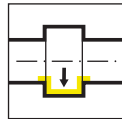

Page/Pag.  
32

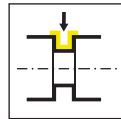

Page/Pag.  
52

Cartouche Graf  
Cartuccia Graf  
IR105

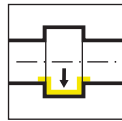

Page/Pag.  
33

Base de support  
Attacco Base  
HC105/L760/BGT

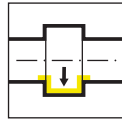

Page/Pag.  
42, 45-46, 48-49

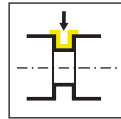

Page/Pag.  
43

Cassette  
Cartuccia  
KC760

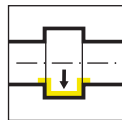

Page/Pag.  
44

Supports réglables  
Portainsero registrabile  
BKT/N

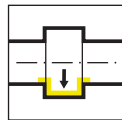

Page/Pag.  
47, 50-51, 55-61

Plat entre Graf  
Distanziale Graff  
Z/N



Page/Pag.  
53, 54

Pièces détachées  
Ricambi

Page/Pag.  
62

Informations techniques  
Informazioni tecniche

Page/Pag.  
63

Appareil de réglage en hauteur  
 Apparecchio per la pre-regolazione degli utensili in altezza  
 HVR.40

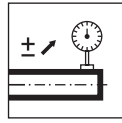

Page/Pag.  
64

Adaptateur  
 Adattatore  
 001C

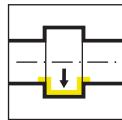

Page/Pag.  
74

Plaque de coupe  
 Insertot  
 105/S105/HSKT40/A105

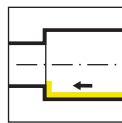

Page/Pag.  
76, 138

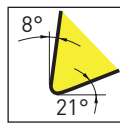

Page/Pag.  
77-82



Page/Pag.  
83



Page/Pag.  
84-91

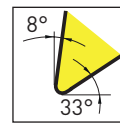

Page/Pag.  
92

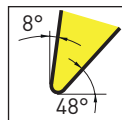

Page/Pag.  
93

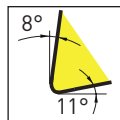

Page/Pag.  
94-97

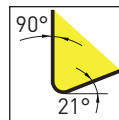

Page/Pag.  
98-99

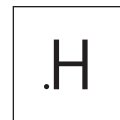

Page/Pag.  
100-101



Page/Pag.  
102-105

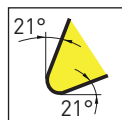

Page/Pag.  
106-107



Page/Pag.  
108

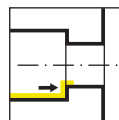

Page/Pag.  
109

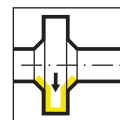

Page/Pag.  
110

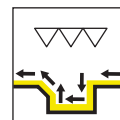

Page/Pag.  
111

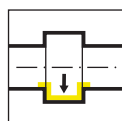

Page/Pag.  
112-120, 137

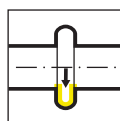

Page/Pag.  
121-123

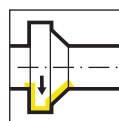

Page/Pag.  
124

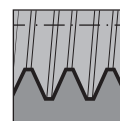

Page/Pag.  
125-134

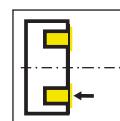

Page/Pag.  
139-144, 147-148

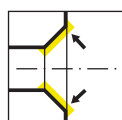

Page/Pag.  
145

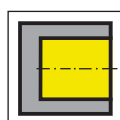

Page/Pag.  
149-150

Plaque  
 Inserto  
 105

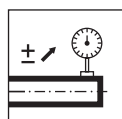

Page/Pag.  
151-152

Ø Alésage Foro Ø	Type de produit / Linea di prodotto											
	105	109	110	106	107	108	10P	111	11P	114	116	18P
≥ 0,2	•											
≥ 0,5	•											
≥ 0,7	•											
≥ 1,0	•											
≥ 1,5	•											
≥ 2,0	•											
≥ 3,0	•											
≥ 4,0	•											
≥ 5,0	•											
≥ 6,0	•	•	•	•								
≥ 6,8		•	•	•								
≥ 7,0		•			•							
≥ 7,8			•		•	•						
≥ 8,0			•		•	•						
≥ 9,0			•		•	•	•					
≥ 10,0			•				•	•	•			
≥ 10,5									•			
≥ 11,0								•	•			
≥ 11,5									•			
≥ 13,8										•		
≥ 14,0										•	•	
≥ 16,0											•	
≥ 16,5										(•)		
≥ 18,0												•
Profondeur de gorge Profondità della gola	2,5	2,5	4,0	0,8	2,0	1,0	3,0	2,3	3,5	4,0 (6,5)	4,3	8,0
Largeur de gorge Larghezza della gola	0,5- 2,0	1,0- 2,0	1,0- 3,0	0,7- 1,5	1,0- 2,0	0,7- 2,0	1,0- 3,0	0,7- 3,0	1,0- 3,0	0,7- 3,0	0,7- 4,0	2,0- 3,0
Type d'usinage / Operazione												
Gorge Gole	•	•	•	•	•	•	•	•	•	•	•	•
Alésage Alesatura	•	•	•	•	•	•			•	•	•	
Filetage Filettatura	•	•			•	•			•	•	•	
Chanfreinage Smussatura	•	•			•	•			•	•	•	
Gorge frontale Gole assiali	•	•	•							•		
Tournage dur Alesatura e profilatura	•											

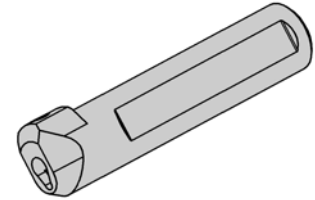
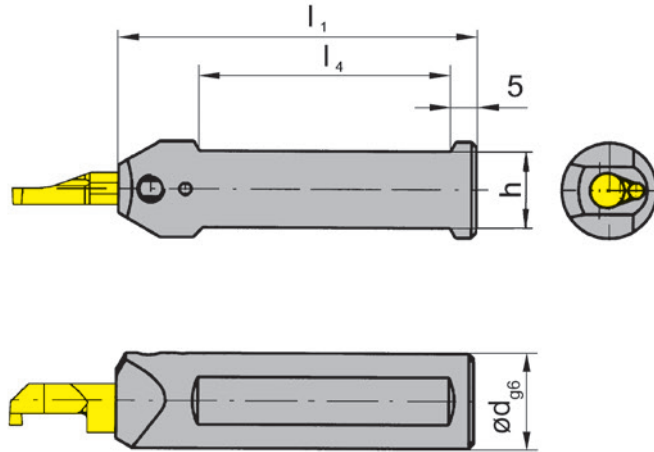
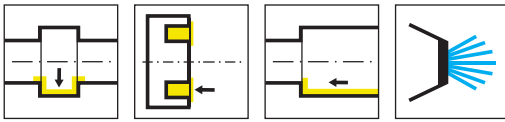

Illustration de coupe à droite représentée  
Figura = taglio destro

Numéro de commande Codice prodotto	d	l <sub>1</sub>	h	l <sub>4</sub>	HWS
<b>B105.0010.01</b>	10	75	9	50	105123 • 105124 • 105125
<b>B105.0012.01</b>	12	75	11	50	105123 • 105124 • 105125
<b>B105.0016.01</b>	16	75	14	50	105123 • 105124 • 105125
<b>B105.0020.01</b>	20	90	18	55	105123 • 105124 • 105125
<b>B105.0022.01</b>	22	90	20	55	105123 • 105124 • 105125
<b>B105.0025.01</b>	25	100	23	55	105123 • 105124 • 105125
<b>B105.0028.01</b>	28	120	26	72	105123 • 105124 • 105125

### Pièces Détachées

Ricambi

Porte outils Portainsero	Vis de serrage Vite di serraggio	Tournevis TORX PLUS® Cacciavite TORX PLUS®
B105...	<b>6.075T15P</b>	<b>T15PQ</b>

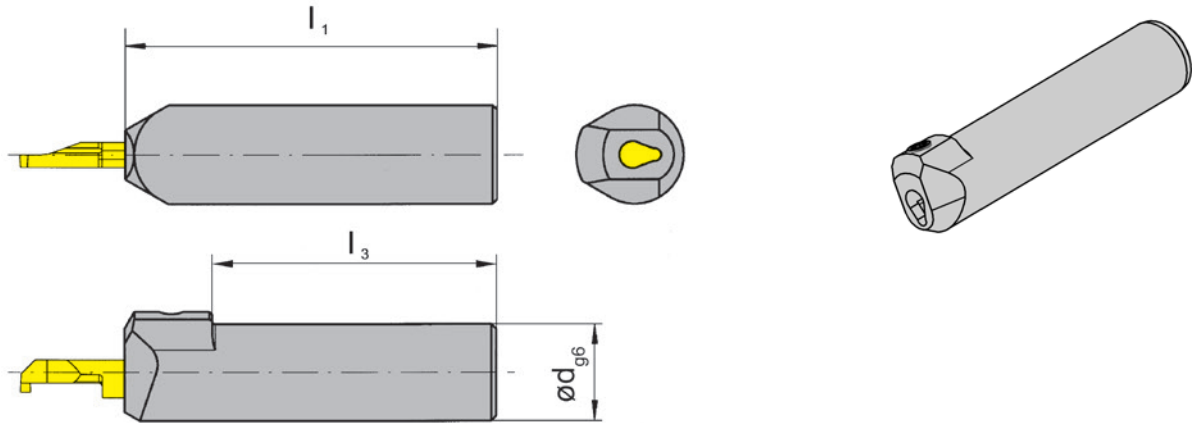
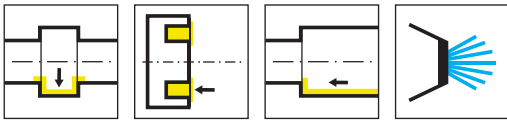

Illustration de coupe à droite représentée  
Figura = taglio destro

Numéro de commande Codice prodotto	d	$l_1$	$l_3$	HWS
<b>B105.0010.01A</b>	10	75	57	105123 • 105124 • 105125
<b>B105.0012.01A</b>	12	75	63	105123 • 105124 • 105125
<b>B105.0016.01A</b>	16	75	63	105123 • 105124 • 105125

### Pièces Détachées

Ricambi

Porte outils Portainsero	Vis de serrage Vite di serraggio	Tournevis TORX PLUS® Cacciavite TORX PLUS®
B105...	<b>6.075T15P</b>	<b>T15PQ</b>

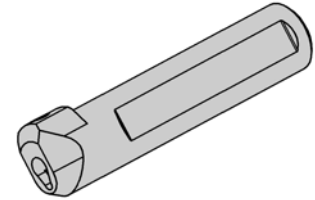
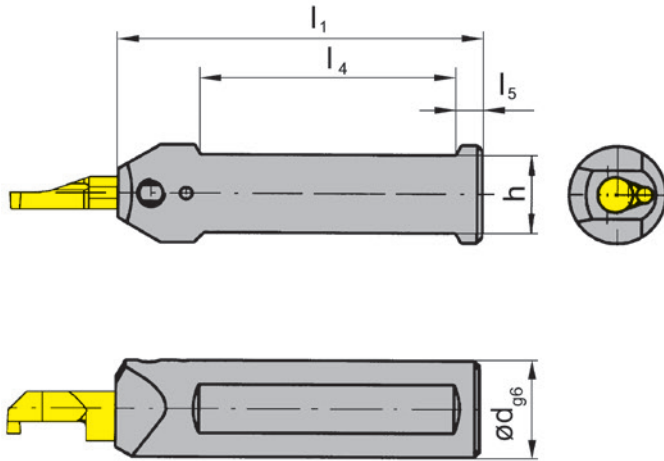
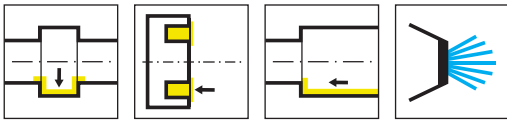

Illustration de coupe à droite représentée  
Figura = taglio destro

Numéro de commande Codice prodotto	d	l <sub>1</sub>	h	l <sub>4</sub>	l <sub>5</sub>	HWS
BU105.0750.5.01	3/4"	90	17,04	70	5	105123 • 105124 • 105125
BU105.0750.5.3.01	3/4"	152,5	17,05	70	5	105123 • 105124 • 105125
BU105.1000.5.01	1"	90	23,4	65	5	105123 • 105124 • 105125
BU105.1000.5.3.01	1"	152,5	23,4	70	5	105123 • 105124 • 105125

Dimensions en pouce et mm  
Dimensioni in pollici e mm

Adaptateur d'arrosage M12x1,5 pour machines Traub.  
Le raccord du liquide de coupe ne fait pas partie de la référence.  
Adattatore refrigerante M12x1,5 per macchina Traub.  
L'adduttore del refrigerante non è incluso

### Pièces Détachées

Ricambi

Porte outils Portainsero	Vis de serrage Vite di serraggio	Tournevis TORX PLUS® Cacciavite TORX PLUS®
BU105...	6.075T15P	T15PQ

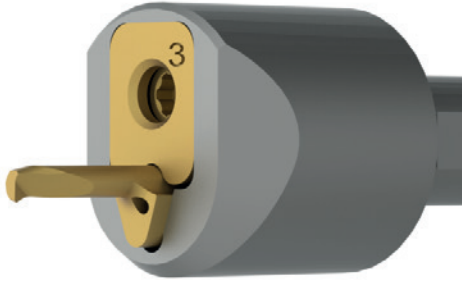

Dimension 3 (HWS = 105123)  
Dimensione 3

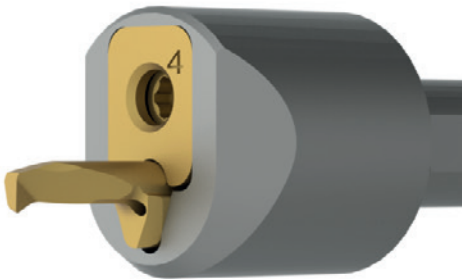
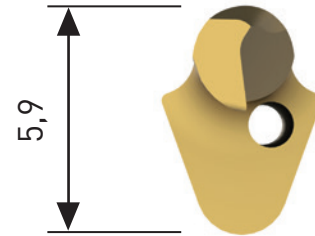

Dimension 4 (HWS = 105124)  
Dimensione 4

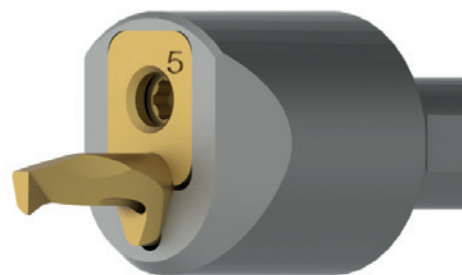
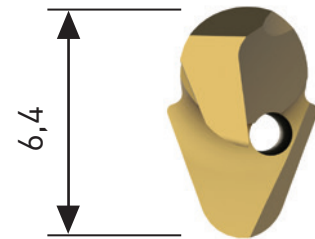

Dimension 5 (HWS = 105125)  
Dimensione 5

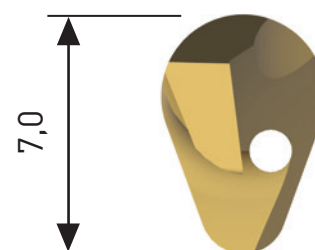

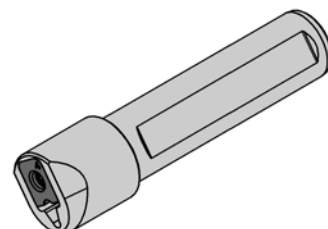
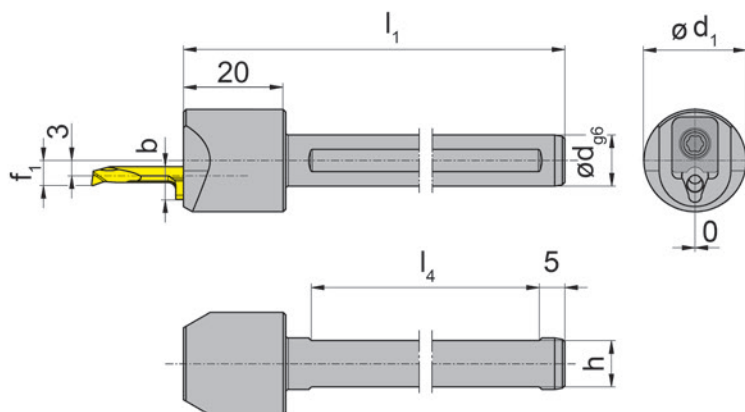
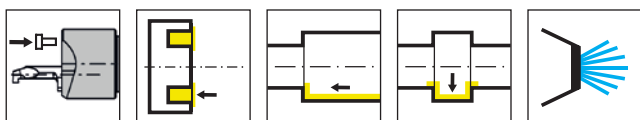

Illustration de coupe à droite représentée

Figura = taglio destro

Número de commande Codice prodotto	d	l <sub>1</sub>	h	l <sub>4</sub>	f <sub>1</sub>	d <sub>1</sub>	b	HWS
B105.0010.S.03	10	80	9	50	4,3	20	5,9	105123
B105.0012.S.03	12	80	11	50	4,3	20	5,9	105123
B105.0016.S.03	16	80	14	50	4,3	20	5,9	105123
B105.0020.S.03	20	90	18	55	4,3	20	5,9	105123
B105.0022.S.03	22	90	20	55	4,3	22	5,9	105123
B105.0025.S.03	25	100	23	55	4,3	25	5,9	105123
B105.0028.S.03	28	120	26	55	4,3	28	5,9	105123
B105.0010.S.04	10	80	9	50	4,9	20	6,4	105124
B105.0012.S.04	12	80	11	50	4,9	20	6,4	105124
B105.0016.S.04	16	80	14	50	4,9	20	6,4	105124
B105.0020.S.04	20	90	18	55	4,9	20	6,4	105124
B105.0022.S.04	22	90	20	55	4,9	22	6,4	105124
B105.0025.S.04	25	100	23	55	4,9	25	6,4	105124
B105.0028.S.04	28	120	26	55	4,9	28	6,4	105124
B105.0010.S.05	10	80	9	50	6,3	20	7	105125
B105.0012.S.05	12	80	11	50	6,3	20	7	105125
B105.0016.S.05	16	80	14	50	6,3	20	7	105125
B105.0020.S.05	20	90	18	55	6,3	20	7	105125
B105.0022.S.05	22	90	20	55	6,3	22	7	105125
B105.0025.S.05	25	100	23	55	6,3	25	7	105125
B105.0028.S.05	28	120	26	55	6,3	28	7	105125

### Pièces Détachées

Ricambi

Porte outils Portainsero	Bride Staffa	Tournevis TORX PLUS® Cacciavite TORX PLUS®
B105.0...03	010.0105.03	T15PL
B105.0...04	010.0105.04	T15PL
B105.0...05	010.0105.05	T15PL

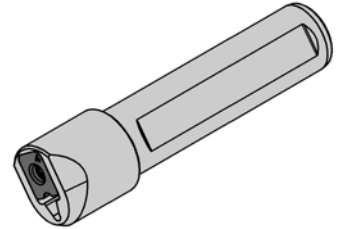
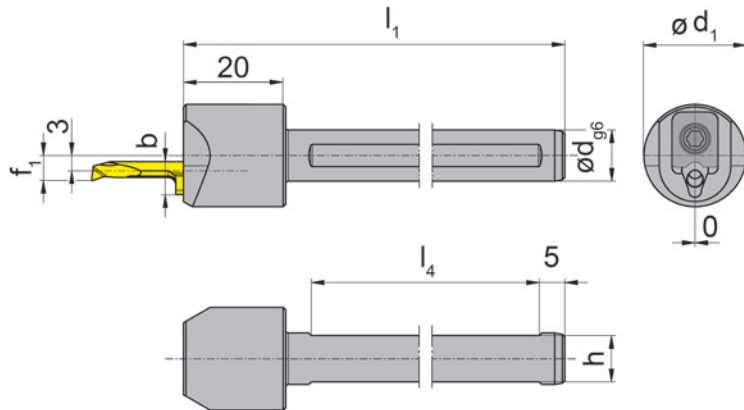
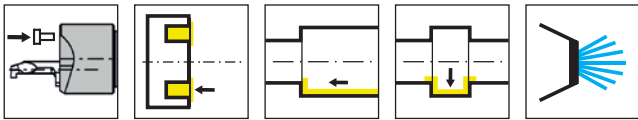

Illustration de coupe à droite représentée

Figura = taglio destro

Numéro de commande Codice prodotto	d	l <sub>1</sub>	h	l <sub>4</sub>	f <sub>1</sub>	d <sub>1</sub>	b	HWS
BU105.0500.S.03	1/2"	80	10,7	50	4,3	20	5,9	105123
BU105.0625.S.03	5/8"	80	13,87	50	4,3	20	5,9	105123
BU105.0750.S.03	3/4"	90	17,05	55	4,3	19,05	5,9	105123
BU105.1000.S.03	1"	90	23,4	55	4,3	25,4	5,9	105123
BU105.0500.S.04	1/2"	80	10,7	50	4,9	20	6,4	105124
BU105.0625.S.04	5/8"	80	13,87	50	4,9	20	6,4	105124
BU105.0750.S.04	3/4"	90	17,05	55	4,9	19,05	6,4	105124
BU105.1000.S.04	1"	90	23,4	55	4,9	25,4	6,4	105124
BU105.0500.S.05	1/2"	80	10,7	50	6,3	20	7	105125
BU105.0625.S.05	5/8"	80	13,87	50	6,3	20	7	105125
BU105.0750.S.05	3/4"	90	17,05	55	6,3	19,05	7	105125
BU105.1000.S.05	1"	90	23,4	55	6,3	25,4	7	105125

Dimensions en pouce et mm  
Dimensioni in pollici e mm

### Pièces Détachées

Ricambi

Porte outils Portainsero	Bride Staffa	Tournevis TORX PLUS® Cacciavite TORX PLUS®
BU105.0...03	010.0105.03	T15PL
BU105.0...04	010.0105.04	T15PL
BU105.0...05	010.0105.05	T15PL

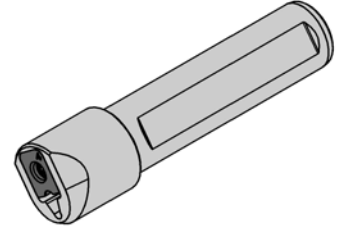
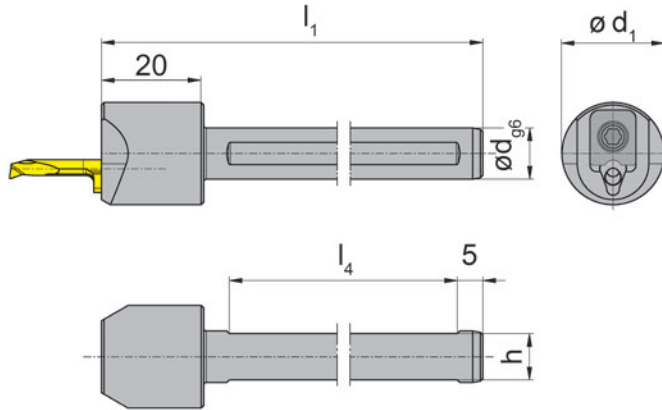
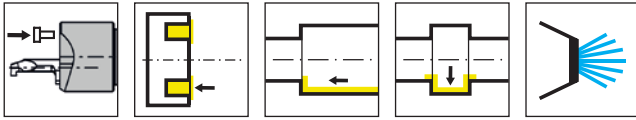

Numéro de commande Codice prodotto	d	h	l <sub>1</sub>	l <sub>4</sub>	d <sub>1</sub>	HWS
<b>B105.0010.S.SET</b>	10	9	80	50	20	105123 • 105124 • 105125
<b>B105.0012.S.SET</b>	12	11	80	50	20	105123 • 105124 • 105125
<b>B105.0016.S.SET</b>	16	14	80	50	20	105123 • 105124 • 105125
<b>B105.0020.S.SET</b>	20	18	90	55	20	105123 • 105124 • 105125
<b>B105.0022.S.SET</b>	22	20	90	55	22	105123 • 105124 • 105125
<b>B105.0025.S.SET</b>	25	23	100	55	25	105123 • 105124 • 105125
<b>B105.0028.S.SET</b>	28	26	120	55	28	105123 • 105124 • 105125

**Note:**

Un set de porte outils contient 3 brides

**Nota:**

Un set di portainsero contiene 3 staffe

**Pièces Détachées**

Ricambi

Porte outils Portainsero	Bride Staffa	Tournevis TORX PLUS® Cacciavite TORX PLUS®
B105...	010.0105.03 010.0105.04 010.0105.05	T15PW

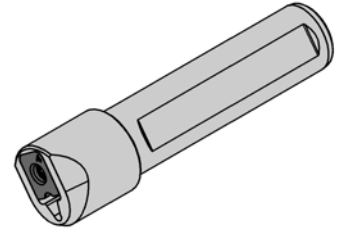
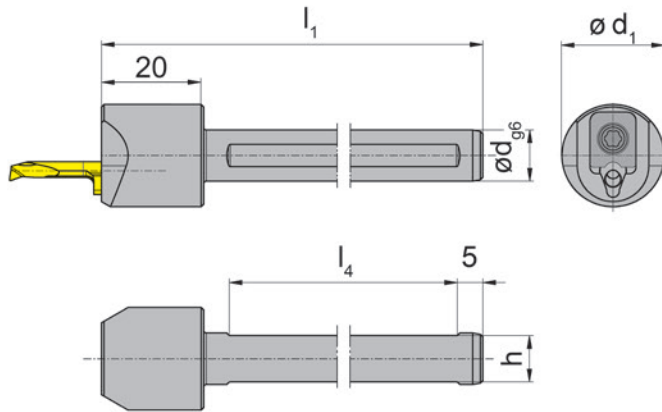
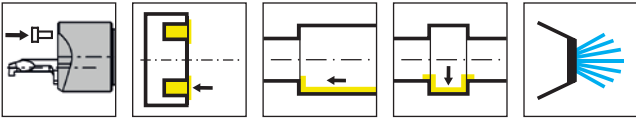

Numéro de commande Codice prodotto	d	h	l <sub>1</sub>	l <sub>4</sub>	d <sub>1</sub>	HWS
<b>BU105.0500.S.SET</b>	.500"	10,7	80	50	20	105123 • 105124 • 105125
<b>BU105.0625.S.SET</b>	.625"	13,875	80	50	20	105123 • 105124 • 105125
<b>BU105.0750.S.SET</b>	.750"	17,05	90	55	.750"	105123 • 105124 • 105125
<b>BU105.1000.S.SET</b>	1"	23,4	90	55	1"	105123 • 105124 • 105125

Dimensions en pouce et mm  
Dimensioni in pollici e mm

**Note:**

Un set de porte outils contient 3 brides

**Nota:**

Un set di portainsero contiene 3 staffe

### Pièces Détachées

Ricambi

Porte outils Portainsero	Bride Staffa	Tournevis TORX PLUS® Cacciavite TORX PLUS®
BU105...	010.0105.03 010.0105.04 010.0105.05	T15PW

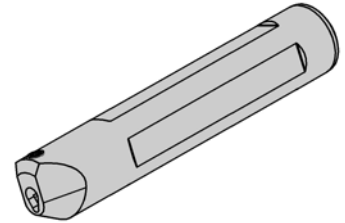
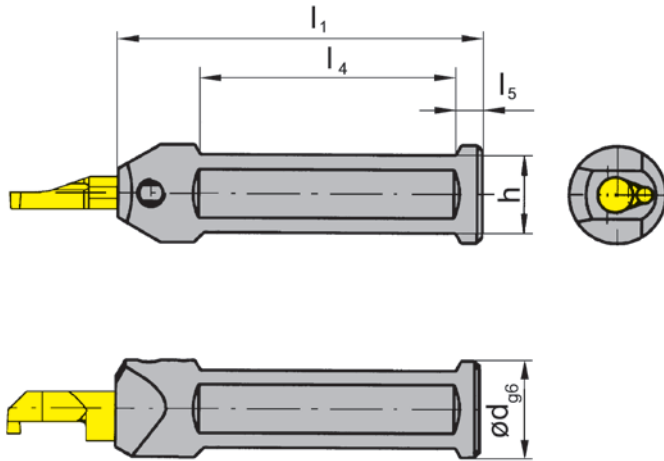
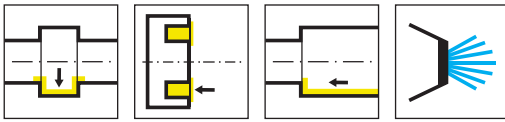

Illustration de coupe à droite représentée  
Figura = taglio destro

Numéro de commande Codice prodotto	d	l <sub>1</sub>	h	l <sub>4</sub>	l <sub>5</sub>	HWS
<b>B105.0022.1.2.01</b>	22	120	20	72	5	105123 • 105124 • 105125

### Pièces Détachées

Ricambi

Porte outils Portainsero	Vis de serrage Vite di serraggio	Tournevis TORX PLUS® Cacciavite TORX PLUS®
B105.0022.1.2.01	<b>6.075T15P</b>	<b>T15PQ</b>



Dimension 3 (HWS = 105123)  
Dimensione 3

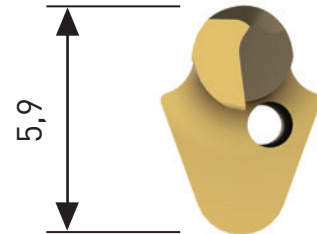

Dimension 4 (HWS = 105124)  
Dimensione 4

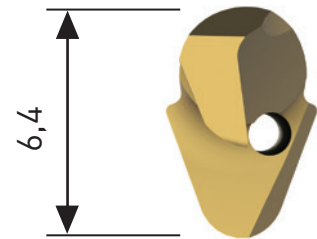

Dimension 5 (HWS = 105125)  
Dimensione 5

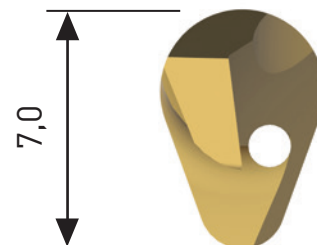

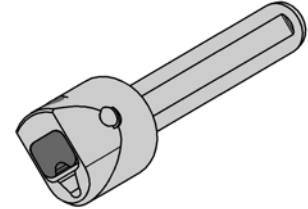
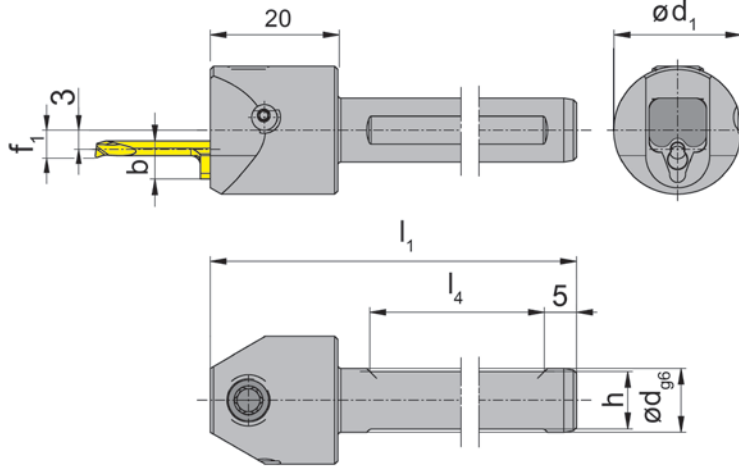
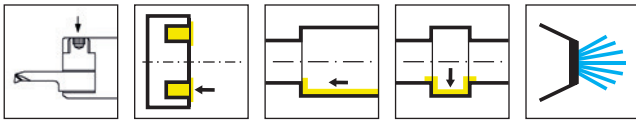

Número de commande Codice prodotto	d	l <sub>1</sub>	h	l <sub>4</sub>	f <sub>1</sub>	d <sub>1</sub>	b	HWS
B105.0010.A.03	10	80	9	50	4,3	20	5,9	105123
B105.0012.A.03	12	80	11	50	4,3	20	5,9	105123
B105.0016.A.03	16	80	14	50	4,3	20	5,9	105123
B105.0020.A.03	20	90	18	55	4,3	20	5,9	105123
B105.0025.A.03	25	100	23	55	4,3	25	5,9	105123
B105.0010.A.04	10	80	9	50	4,9	20	6,4	105124
B105.0012.A.04	12	80	11	50	4,9	20	6,4	105124
B105.0016.A.04	16	80	14	50	4,9	20	6,4	105124
B105.0020.A.04	20	90	18	55	4,9	20	6,4	105124
B105.0025.A.04	25	100	23	55	4,9	25	6,4	105124
B105.0010.A.05	10	80	9	50	6,3	20	7	105125
B105.0012.A.05	12	80	11	50	6,3	20	7	105125
B105.0016.A.05	16	80	14	50	6,3	20	7	105125
B105.0020.A.05	20	90	18	55	6,3	20	7	105125
B105.0025.A.05	25	100	23	55	6,3	25	7	105125

b = hauteur d'plaquette  
b = altezza inserto

### Pièces Détachées

Ricambi

Porte outils Portainsero	Bride Staffa	Tournevis TORX PLUS® Cacciavite TORX PLUS®
B105.0...03	010.0003.0668	T25PQ
B105.0...04	010.0004.0667	T25PQ
B105.0...05	010.0005.0663	T25PQ

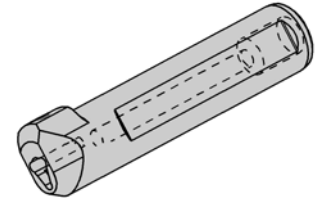
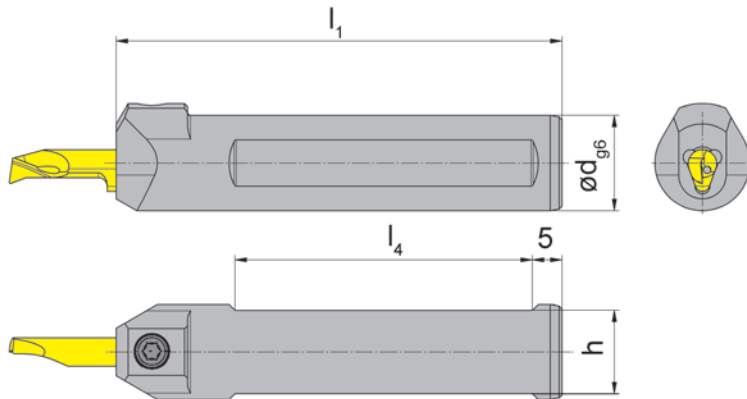
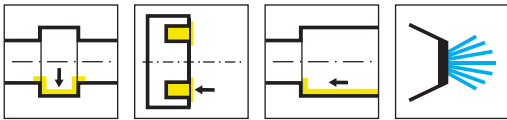
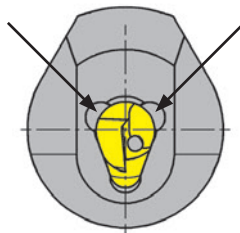

Illustration de coupe à droite représentée

Figura = taglio destro

Numéro de commande Codice prodotto	d	l <sub>1</sub>	h	l <sub>4</sub>	HWS
<b>B105.0012.K.01</b>	12	75	11	50	105123 • 105124 • 105125
<b>B105.0016.K.01</b>	16	75	14	50	105123 • 105124 • 105125
<b>B105.0020.K.01</b>	20	90	18	50	105123 • 105124 • 105125
<b>B105.0022.K.01</b>	22	90	20	55	105123 • 105124 • 105125
<b>B105.0025.K.01</b>	25	100	23	55	105123 • 105124 • 105125
<b>B105.0012.M8.K.01</b>	12	75	11	50	105123 • 105124 • 105125
<b>B105.0016.M8.K.01</b>	16	75	14	50	105123 • 105124 • 105125
<b>B105.0020.M8.K.01</b>	20	90	18	55	105123 • 105124 • 105125

arrosage additionnelle  
con adduzione refrigerante supplementare



### Pièces Détachées

Ricambi

Porte outils Portainsero	Vis de serrage Vite di serraggio	Tournevis TORX PLUS® Cacciavite TORX PLUS®
B105...	<b>6.075T15P</b>	<b>T15PQ</b>

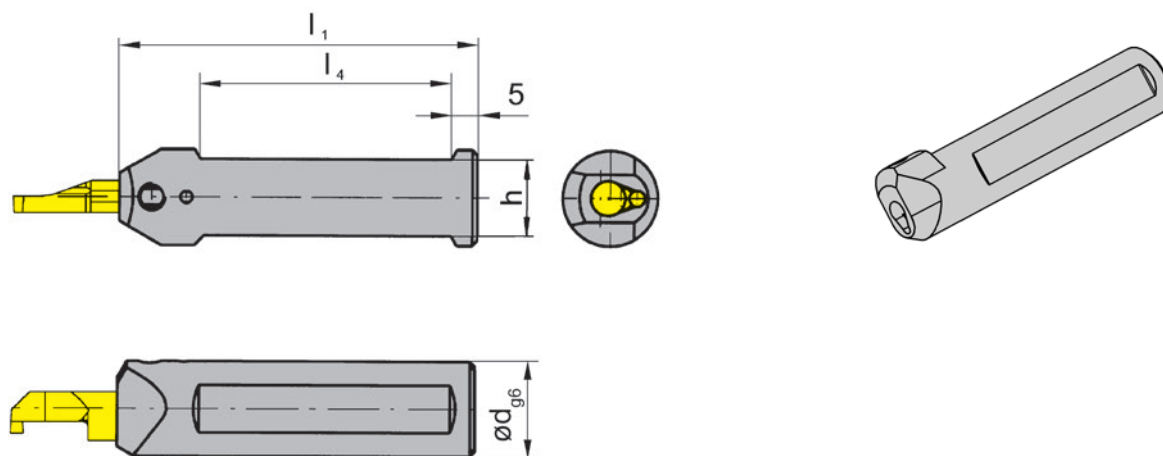
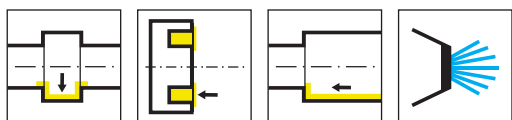

Illustration de coupe à droite représentée

Figura = taglio destro

Numéro de commande Codice prodotto	d	l <sub>1</sub>	h	l <sub>4</sub>	HWS
<b>B105.0012.M8.01</b>	12	75	11	50	105123 • 105124 • 105125
<b>B105.0016.M8.01</b>	16	75	14	50	105123 • 105124 • 105125
<b>B105.0020.M8.01</b>	20	90	18	55	105123 • 105124 • 105125
<b>B105.0025.M8.01</b>	25	100	23	55	105123 • 105124 • 105125

### Pièces Détachées

Ricambi

Porte outils Portainsero	Vis de serrage Vite di serraggio	Tournevis TORX PLUS® Cacciavite TORX PLUS®
B105...	<b>6.075T15P</b>	<b>T15PQ</b>

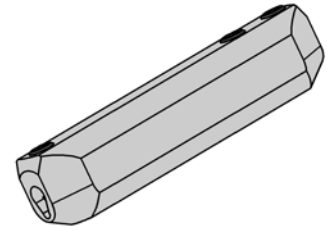
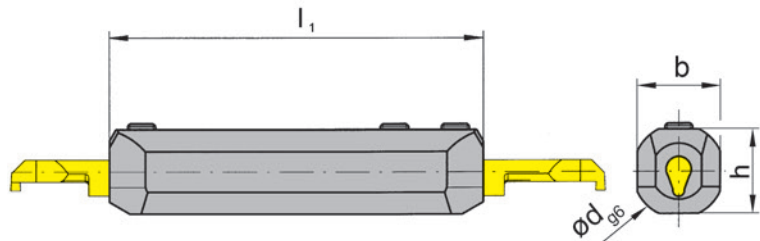
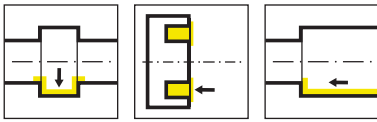

Plaque type 105  
Inserto tipo 105

Plaque type 105...2 (Logement plaque rallongé)  
Inserto tipo 105...2 (Sede alloggiamento inserto maggiorata)

Illustration de coupe à droite représentée

Figura = taglio destro

Numéro de commande Codice prodotto	d	l <sub>1</sub>	h	b	HWS
<b>B105.0020.1.03</b>	20	80	18	18	105123 • 105124 • 105125 • 105225

### Pièces Détachées

Ricambi

Porte outils Portainsero	Vis de serrage Vite di serraggio	Tournevis TORX PLUS® Cacciavite TORX PLUS®
B105.0020.1.03	<b>6.075T15P</b>	<b>T15PQ</b>

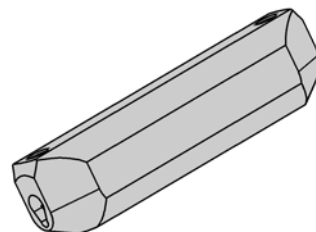
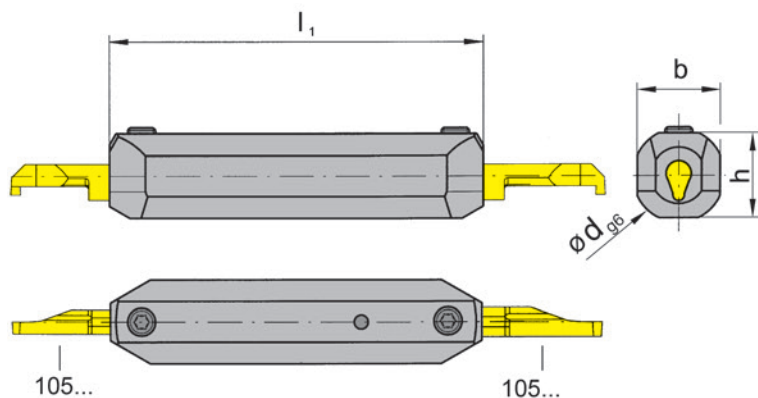
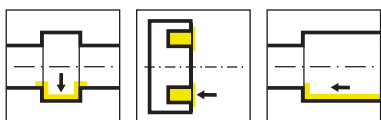

Illustration de coupe à droite représentée  
Figura = taglio destro

Numéro de commande Codice prodotto	d	l <sub>1</sub>	h	b	HWS
B105.0022.2.1.01	22	80	20	20	105123 • 105124 • 105125
B105.0022.2.2.01	22	120	20	20	105123 • 105124 • 105125

### Pièces Détachées

Ricambi

Porte outils Portainsero	Vis de serrage Vite di serraggio	Tournevis TORX PLUS® Cacciavite TORX PLUS®
B105...	6.075T15P	T15PQ

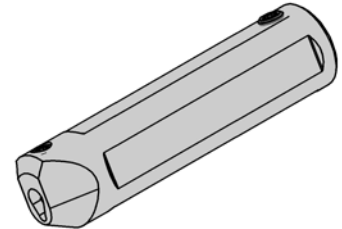
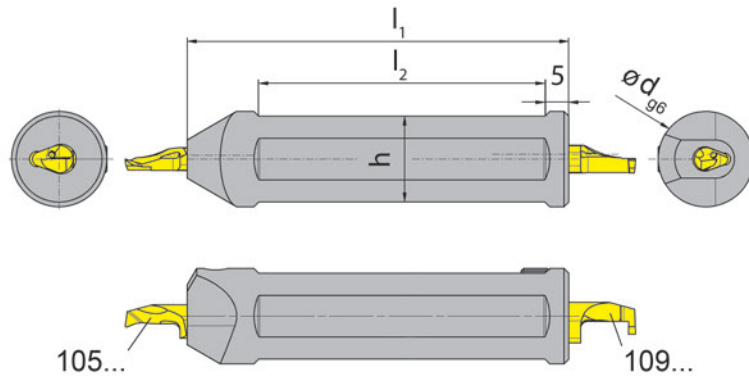
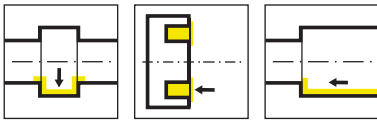

Illustration de coupe à droite représentée

Figura = taglio destro

Numéro de commande Codice prodotto	d	l <sub>1</sub>	h	l <sub>2</sub>	HWS
<b>B105.0020.1.09</b>	20	80	18	60	105123 • 105124 • 105125 • 109140

### Pièces Détachées

Ricambi

Porte outils Portainsero	Vis de serrage Vite di serraggio	Tournevis TORX PLUS® Cacciavite TORX PLUS®
B105.0020.1.09	<b>6.075T15P</b>	<b>T15PQ</b>

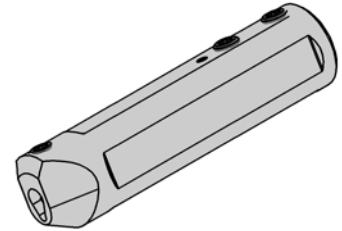
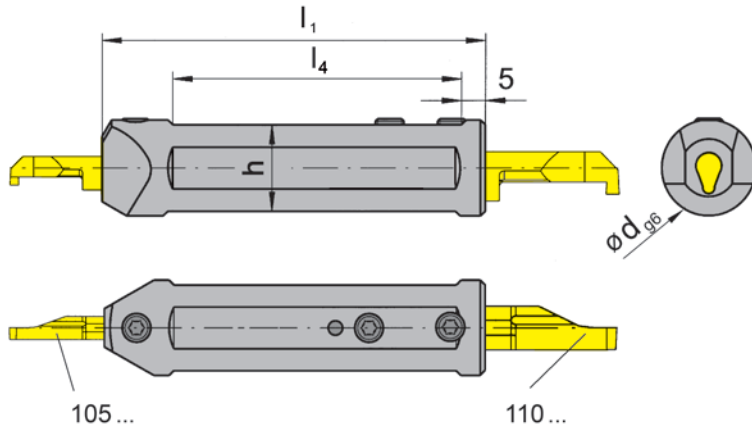
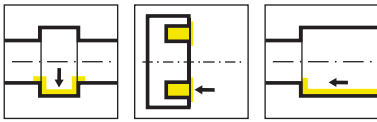

Illustration de coupe à droite représentée  
Figura = taglio destro

Numéro de commande Codice prodotto	d	l <sub>1</sub>	h	l <sub>4</sub>	HWS
<b>B105.0020.1.10</b>	20	80	18	60	105123 • 105124 • 105125 • 110260

**Pièces Détachées**

Ricambi

Porte outils Portainsero	Vis de serrage Vite di serraggio	Tournevis TORX PLUS® Cacciavite TORX PLUS®
B105.0020.1.10	<b>6.075T15P</b>	<b>T15PQ</b>

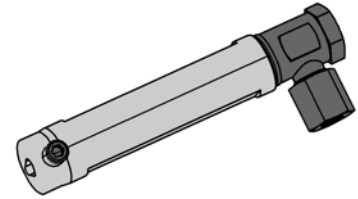
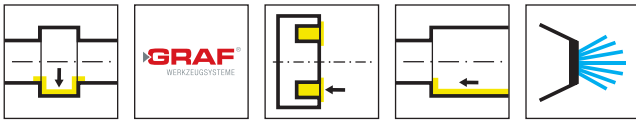

Illustration de coupe à droite représentée

Figura = taglio destro

Número de commande Codice prodotto	d	L <sub>1</sub>	Type de machine Tipo macchina	HWS
IR.105.34.100.IK	3/4"	100	Citizen	105123 • 105124 • 105125
IR.105.34.40.IK	3/4"	40	Citizen	105123 • 105124 • 105125
IR.105.34.50.IK	3/4"	50	Citizen	105123 • 105124 • 105125
IR.105.34.70.IK	3/4"	70	Citizen	105123 • 105124 • 105125
IR.105.10.100.IK	1"	100	Citizen	105123 • 105124 • 105125
IR.105.10.60.IK	1"	60	Citizen	105123 • 105124 • 105125
IR.105.20.30.IK	20	30	Citizen	105123 • 105124 • 105125
IR.105.20.50.IK	20	50	Citizen	105123 • 105124 • 105125
IR.105.16.100.IK	16	100	Star	105123 • 105124 • 105125
IR.105.16.30.IK	16	30	Star	105123 • 105124 • 105125
IR.105.16.50.IK	16	50	Star	105123 • 105124 • 105125
IR.105.16.70.IK	16	70	Star	105123 • 105124 • 105125
IR.105.20.100.IK	20	100	Star	105123 • 105124 • 105125
IR.105.22.100.IK	22	100	Star	105123 • 105124 • 105125
IR.105.22.120.3.IK	22	120	Star	105123 • 105124 • 105125
IR.105.22.120.IK	22	120	Star	105123 • 105124 • 105125
IR.105.22.150.IK	22	150	Star	105123 • 105124 • 105125
IR.105.22.38.IK	22	38	Star	105123 • 105124 • 105125
IR.105.22.50.IK	22	50	Star	105123 • 105124 • 105125
IR.105.22.70.IK	22	70	Star	105123 • 105124 • 105125
IR.105.20.170.IK	20	170	Tornos	105123 • 105124 • 105125
IR.105.20.185.IK	20	185	Tornos	105123 • 105124 • 105125
IR.105.25.100.IK	25	100	Tornos	105123 • 105124 • 105125
IR.105.25.150.IK	25	150	Tornos	105123 • 105124 • 105125
IR.105.28.80.IK	28	80	Tornos	105123 • 105124 • 105125

Dimensions en pouce et mm  
Dimensioni in pollici e mm

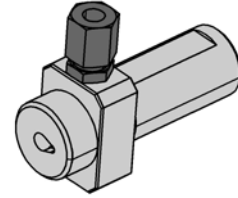
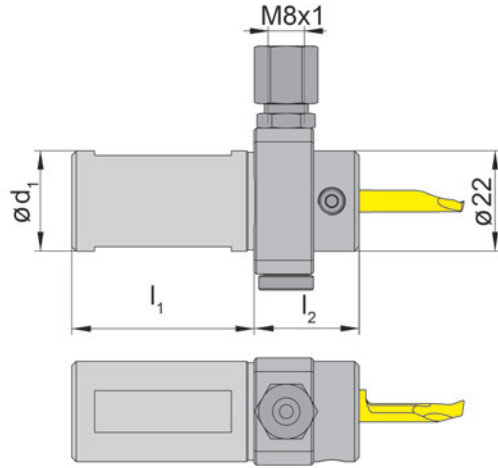
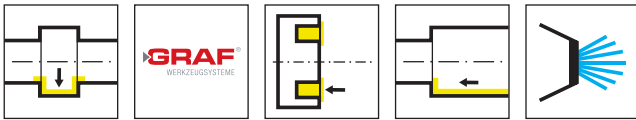

Illustration de coupe à droite représentée  
Figura = taglio destro

Numéro de commande Codice prodotto	d <sub>1</sub>	l <sub>1</sub>	l <sub>2</sub>	HWS
<b>IR.105.1640.IKV</b>	16	40	25	105123 • 105124 • 105125
<b>IR.105.3440.IKV</b>	3/4"	40	25	105123 • 105124 • 105125
<b>IR.105.2040.IKV</b>	20	40	25	105123 • 105124 • 105125
<b>IR.105.2240.IKV</b>	22	40	25	105123 • 105124 • 105125
<b>IR.105.2560.IKV</b>	25	60	25	105123 • 105124 • 105125
<b>IR.105.1060.IKV</b>	1"	60	25	105123 • 105124 • 105125

Dimensions en pouce et mm  
Dimensioni in pollici e mm

**Pièces Détachées**

Ricambi

Cartouche Graf Cartuccia Graf	Vis de serrage Vite di serraggio	Arrosage Lubrificazione	Tournevis TORX PLUS® Cacciavite TORX PLUS®
IR...	<b>6.075T15P</b>	<b>004.00.19</b>	<b>T15PQ</b>

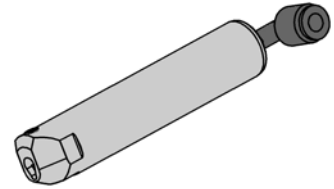
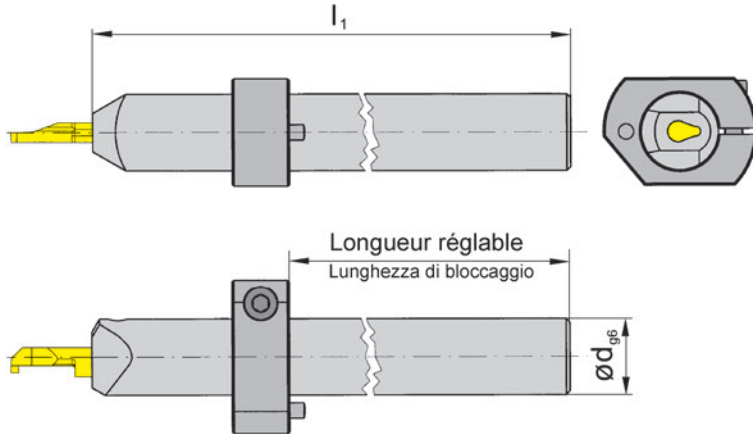
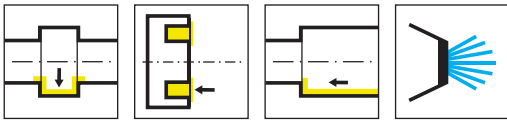

Illustration de coupe à droite représentée

Figura = taglio destro

Número de commande Codice prodotto	d	$l_1$	HWS
<b>B105.0020.2.01</b>	20	150	105123 • 105124 • 105125
<b>B105.0025.2.01</b>	25	150	105123 • 105124 • 105125

Bague de réglage vendue séparément!

La boccia di regolazione non viene fornita con il portainsero - bisogna ordinarla separatamente!

Bague de réglage Boccola di regolazione	d	Type de machine Tipo di macchina
<b>020.0020.1665</b>	20	Tornos
<b>020.0025.2234</b>	25	Tornos

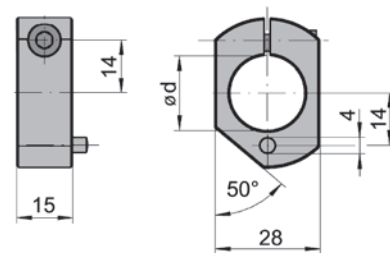

### Pièces Détachées

Ricambi

Porte outils Portainsero	Vis de serrage Vite di serraggio	Tournevis TORX PLUS® Cacciavite TORX PLUS®
B105...	<b>6.075T15P</b>	<b>T15PQ</b>

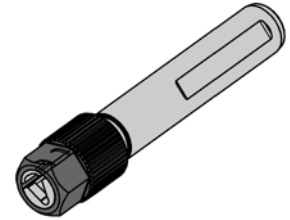
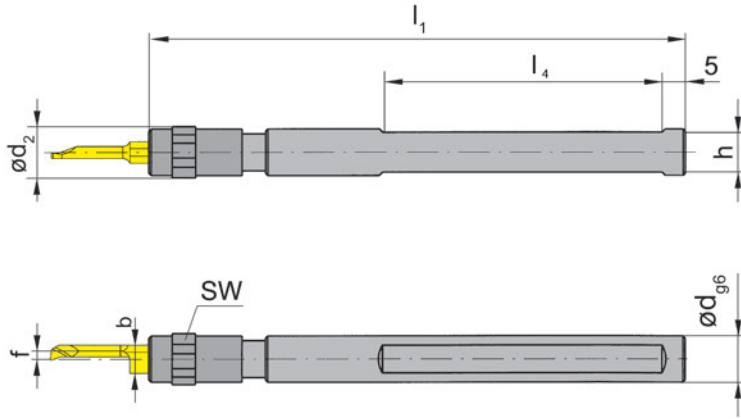
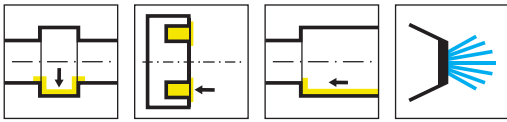

Illustration de coupe à droite représentée  
Figura = taglio destro

Numéro de commande Codice prodotto	d	$l_1$	h	$l_4$	f	$d_2$	SW	b	HWS
<b>B105.0010.9.01</b>	10	100	9	50	1,6	11	10	5,9	105123
<b>B105.0012.11.01</b>	12	100	11	50	1,2	16	13	7	105125
<b>B105.0016.11.01</b>	16	100	15	50	1,2	16	13	7	105125

b = hauteur d'plaque  
b = altezza inserto

**Pièces Détachées**  
Ricambi

Porte outils Portainsero	Baguette de serrage Ghiera di bloccaggio
B105.0010.9.01	<b>020.0010.1719</b>
B105.00...	<b>020.0016.1999</b>

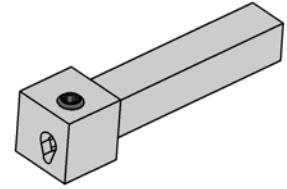
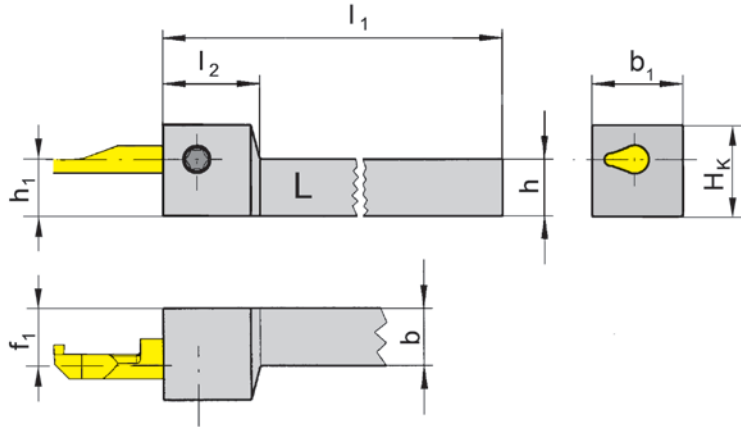
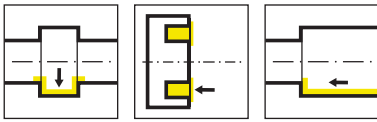

L = version à gauche représentée  
L = versione sinistra come in figura

R = version à droite  
R = versione destra a specchio

Numéro de commande Codice prodotto	h	b	$l_1$	$h_1$	$b_1$	$f_1$	$H_k$	$l_2$	HWS
<b>RH105.0808.01</b>	8	8	90	8	16	7,5	14	17	105123 • 105124 • 105125
<b>RH105.1010.01</b>	10	10	90	10	16	7,5	16	17	105123 • 105124 • 105125
<b>RH105.1212.01</b>	12	12	90	12	16	7,5	18	17	105123 • 105124 • 105125
<b>RH105.1616.01</b>	16	16	110	16	16	7,5	22	17	105123 • 105124 • 105125
<b>LH105.0808.01</b>	8	8	90	8	16	7,5	14	17	105123 • 105124 • 105125
<b>LH105.1010.01</b>	10	10	90	10	16	7,5	16	17	105123 • 105124 • 105125
<b>LH105.1212.01</b>	12	12	90	12	16	7,5	18	17	105123 • 105124 • 105125
<b>LH105.1616.01</b>	16	16	110	16	16	7,5	22	17	105123 • 105124 • 105125

### Pièces Détachées

Ricambi

Porte outils Portainsero	Vis de serrage Vite di serraggio	Tournevis TORX PLUS® Cacciavite TORX PLUS®
R/LH105...	<b>6.075T15P</b>	<b>T15PQ</b>

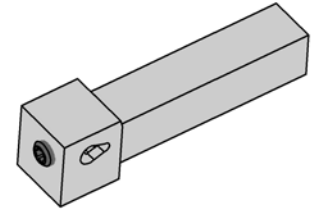
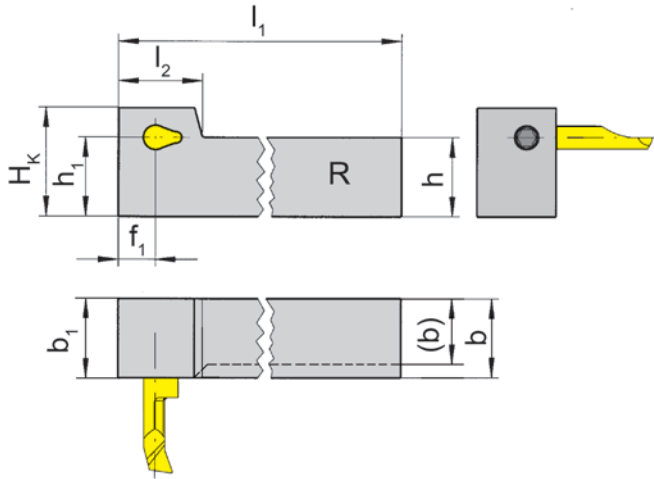
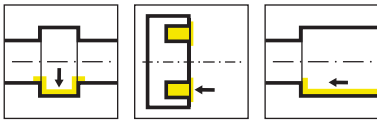

R = version à droite représentée  
R = versione destra come in figura

L = version à gauche  
L = versione sinistra a specchio

Numéro de commande Codice prodotto	h	b	l <sub>1</sub>	l <sub>2</sub>	h <sub>1</sub>	b <sub>1</sub>	f <sub>1</sub>	H <sub>k</sub>	HWS
<b>RHC105.1212.01</b>	12	12	90	17	12	16	7,5	18	105123 • 105124 • 105125
<b>RHC105.1616.01</b>	16	16	130	17	16	16	7,5	22	105123 • 105124 • 105125
<b>LHC105.1212.01</b>	12	12	90	17	12	16	7,5	18	105123 • 105124 • 105125
<b>LHC105.1616.01</b>	16	16	130	17	16	16	7,5	22	105123 • 105124 • 105125

**Pièces Détachées**

Ricambi

Porte outils Portainsero	Vis de serrage Vite di serraggio	Tournevis TORX PLUS® Cacciavite TORX PLUS®
R/LHC105...	<b>6.075T15P</b>	<b>T15PQ</b>

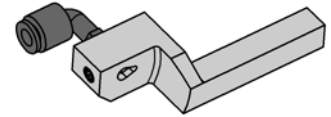
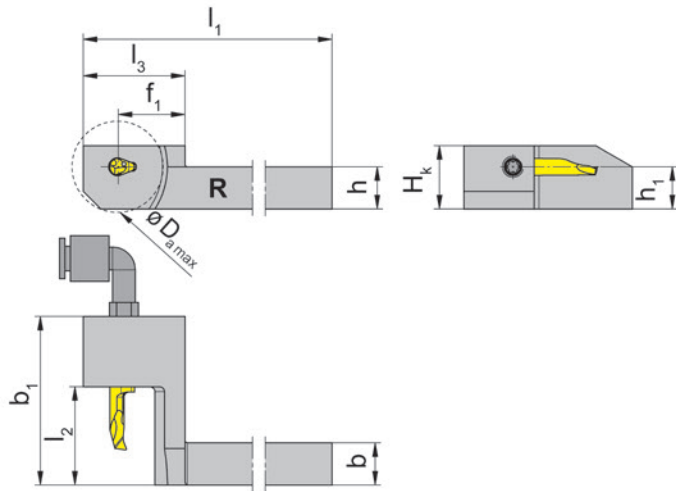
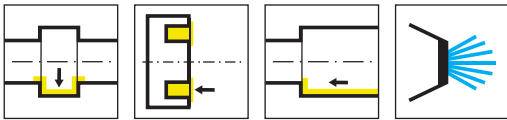

R = version à droite représentée  
R = versione destra come in figura

L = version à gauche  
L = versione sinistra a specchio

Número de commande Codice prodotto	h	b	l <sub>1</sub>	l <sub>3</sub>	h <sub>1</sub>	b <sub>1</sub>	f <sub>1</sub>	D <sub>a max</sub>	H <sub>K</sub>	l <sub>2</sub>	HWS
RHC105.0808.21	8	8	99	29	8	32	19	26	13	18	105123 • 105124 • 105125
RHC105.1010.11	10	10	99	29	10	22,7	19	26	16	8	105123 • 105124 • 105125
RHC105.1010.21	10	10	99	29	10	38	19	26	16	18	105123 • 105124 • 105125
RHC105.1010.41	10	10	99	29	10	48	19	26	16	28	105123 • 105124 • 105125
RHC105.1212.21	12	12	99	29	12	38	19	26	18	18	105123 • 105124 • 105125
RHC105.1212.41	12	12	99	29	12	48	19	26	18	28	105123 • 105124 • 105125
RHC105.1616.21	16	16	104	34	16	38	24	36	22	18	105123 • 105124 • 105125
RHC105.1616.41	16	16	104	34	16	48	24	36	22	28	105123 • 105124 • 105125
LHC105.0808.21	8	8	99	29	8	32	19	26	13	18	105123 • 105124 • 105125
LHC105.1212.21	12	12	99	29	12	38	19	26	18	18	105123 • 105124 • 105125
LHC105.1616.21	16	16	104	34	16	38	24	36	22	18	105123 • 105124 • 105125

Arrosage par l'intermédiaire du raccord  
Lubrificazione tramite raccordo angolare

**R/LHC105.08.../.1010.11 sans arrosage central**  
R/LHC105.08.../.1010.11 senza lubrificazione

### Pièces Détachées

Ricambi

Porte outils Portainsero	Vis de serrage Vite di serraggio	Tournevis TORX PLUS® Cacciavite TORX PLUS®
R/LHC105...	<b>6.075T15P</b>	<b>T15PQ</b>

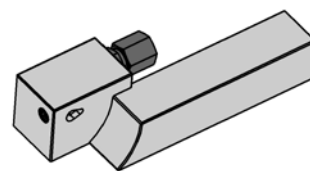
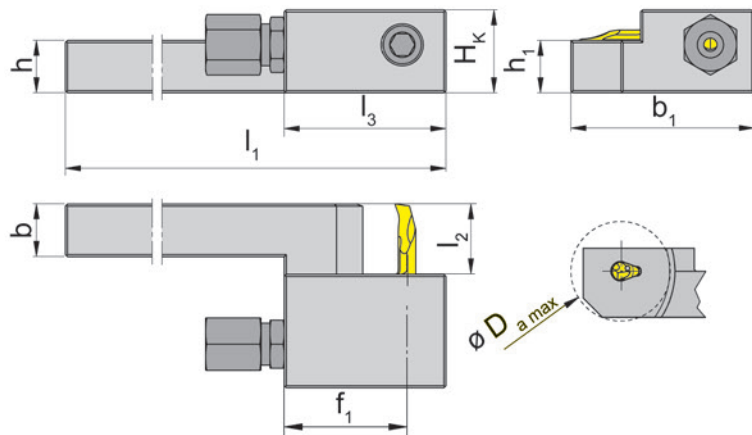
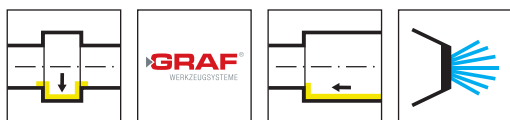

R = version à droite représentée  
R = versione destra come in figura

L = version à gauche  
L = versione sinistra a specchio

Numéro de commande Codice prodotto	h	b	f <sub>1</sub>	l <sub>1</sub>	l <sub>3</sub>	h <sub>1</sub>	H <sub>k</sub>	b <sub>1</sub>	l <sub>2</sub>	D <sub>a max</sub>	HWS
962.08.01.R.IK	8	8	27	130	37	8	15	42	18	30	105123 • 105124 • 105125
962.08.02.L.IK	8	8	27	130	37	8	15	42	18	30	105123 • 105124 • 105125
962.10.01.R.IK	10	10	27	130	37	10	17	42	18	30	105123 • 105124 • 105125
962.10.02.L.IK	10	10	27	130	37	10	17	42	18	30	105123 • 105124 • 105125
962.10.03.R.IK	10	10	27	130	37	10	17	57	33	30	105123 • 105124 • 105125
962.10.04.L.IK	10	10	27	130	37	10	7	57	33	30	105123 • 105124 • 105125
962.12.01.R.IK	12	12	27	130	37	12	19	42	18	30	105123 • 105124 • 105125
962.12.02.L.IK	12	12	27	130	37	12	19	42	18	30	105123 • 105124 • 105125
962.12.03.R.IK	12	12	27	130	37	12	19	57	33	30	105123 • 105124 • 105125
962.12.04.L.IK	12	12	27	130	37	12	19	57	33	30	105123 • 105124 • 105125
962.16.01.R.IK	16	16	27	130	37	16	23	42	18	34	105123 • 105124 • 105125
962.16.02.L.IK	16	16	27	130	37	16	23	42	18	34	105123 • 105124 • 105125
962.16.03.R.IK	16	16	27	130	37	16	23	57	33	34	105123 • 105124 • 105125
962.16.04.L.IK	16	16	27	130	37	16	23	57	33	34	105123 • 105124 • 105125
962.20.01.R.IK	20	20	27	130	37	20	27	42	18	34	105123 • 105124 • 105125
962.20.02.L.IK	20	20	27	130	37	20	27	42	18	34	105123 • 105124 • 105125

Ajustement du liquide de coupe  
Refrigerazione attraverso innesto idraulico

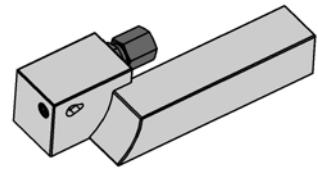
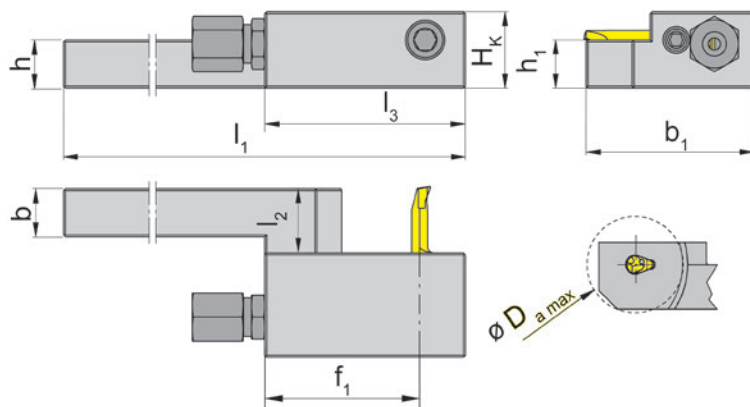
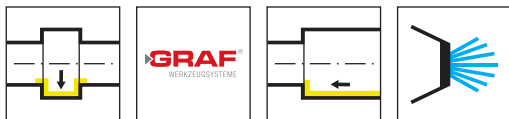

R = version à droite représentée  
R = versione destra come in figura

L = version à gauche  
L = versione sinistra a specchio

Numéro de commande Codice prodotto	h	b	f <sub>1</sub>	l <sub>1</sub>	l <sub>3</sub>	h <sub>1</sub>	H <sub>k</sub>	b <sub>1</sub>	l <sub>2</sub>	D <sub>a max</sub>	HWS
963.12.01.R.IK	12	12	40	130	50	12	19	42	18	46	105123 • 105124 • 105125
963.12.02.L.IK	12	12	40	130	50	12	19	42	18	46	105123 • 105124 • 105125
963.16.01.R.IK	16	16	45	130	50	16	23	42	18	52	105123 • 105124 • 105125
963.16.02.L.IK	16	16	45	130	50	16	23	42	18	52	105123 • 105124 • 105125

Ajustement du liquide de coupe  
Refrigerazione attraverso innesto idraulico

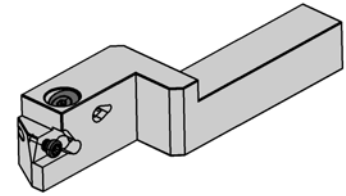
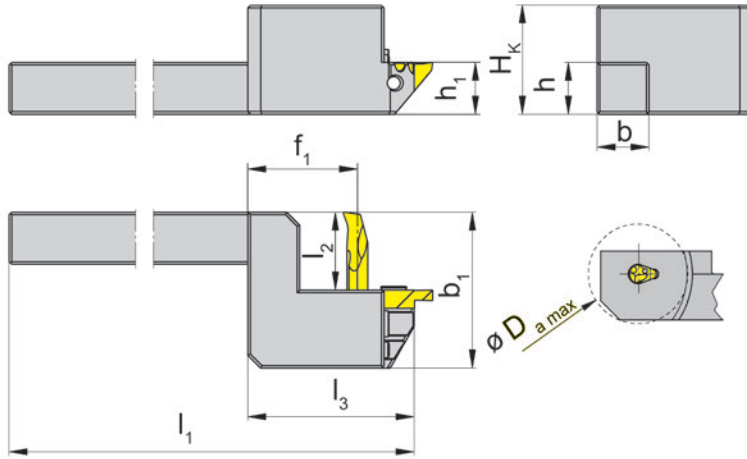

R = version à droite représentée  
R = versione destra come in figura

L = version à gauche  
L = versione sinistra a specchio

Numéro de commande Codice prodotto	h	b	f <sub>1</sub>	l <sub>1</sub>	l <sub>3</sub>	h <sub>1</sub>	H <sub>k</sub>	b <sub>1</sub>	l <sub>2</sub>	D <sub>a max</sub>	HWS
AIH.974.R.1212.K04	12	12	23	130	50	12	19	33	16,5	20	105123 • 105124 • 105125 • 274040R
AIH.974.R.1616.K04	16	16	26	130	50	16	23	33	16,5	26	105123 • 105124 • 105125 • 274040R
AIH.974.R.2020.K04	20	20	29	130	55	20	27	33	16,5	32	105123 • 105124 • 105125 • 274040R

Pièces Détachées

Ricambi

Porte outils Portainsero	Vis de serrage Vite di serraggio	Tournevis TORX PLUS® Cacciavite TORX PLUS®
AIH...	6.075T15P	T15PQ

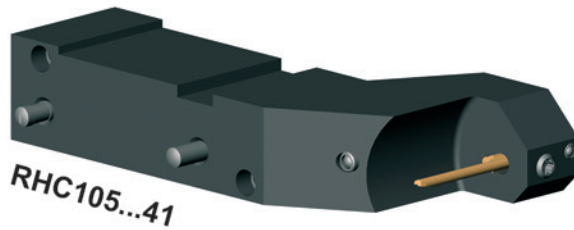
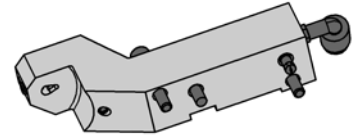
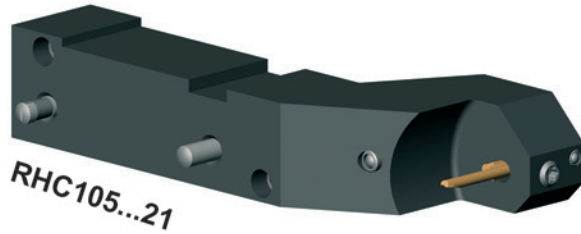

N° de commande Codice prodotto	Type de machine Tipo macchina	Plaqueette Inserto	HWS	HMS
<b>RHC105.0710.21</b>	EvoDECO 10	105...21 l <sub>2</sub> jusqu'à/fino a 15 mm	105123 • 105124 • 105125	Tornos
<b>RHC105.0710.41</b>	EvoDECO 10	105...41 l <sub>2</sub> jusqu'à/fino a 25 mm	105123 • 105124 • 105125	Tornos

Porte outils pour Tornos  
Portainseriti per Tornos

### Pièces Détachées

Ricambi

Base de support Attacco Base	Vis de serrage Vite di serraggio	Tournevis TORX PLUS® Cacciavite TORX PLUS®
RHC105...	<b>6.075T15P</b>	<b>T15PQ</b>

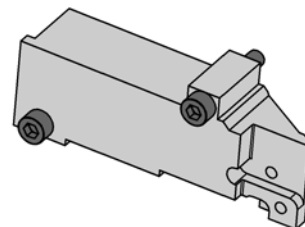
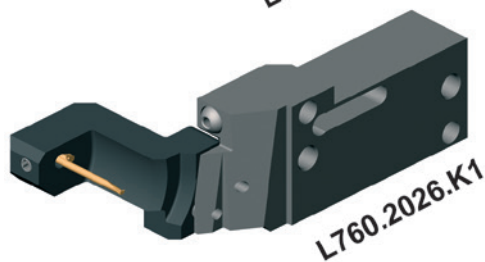
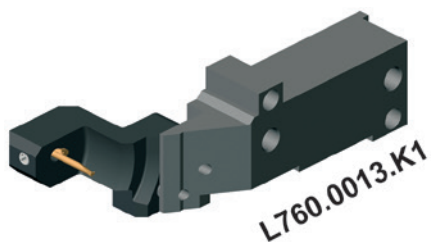
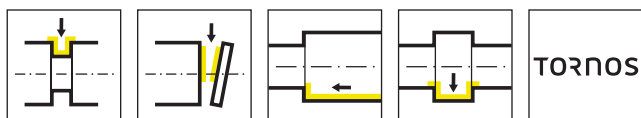

N° de commande Codice prodotto	Plaquette Inserto	Cassette Cartuccia	Type de machine Tipo macchina
L760.0013.K1	105...21 l <sub>2</sub> jusqu'à/fino a 15 mm	RKC760.0105.21	EvoDECO 16
L760.2026.K1	105...41 l <sub>2</sub> jusqu'à/fino a 25 mm	RKC760.0105.41	EvoDECO 20/ EvoDECO 32

Porte outils pour Tornos  
Portainseriti per Tornos

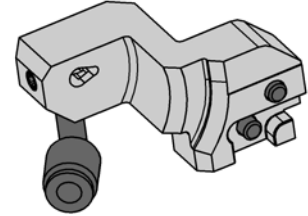
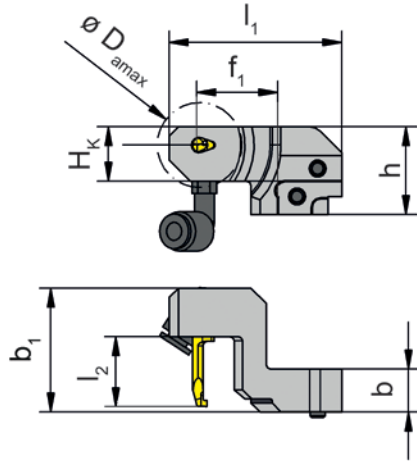
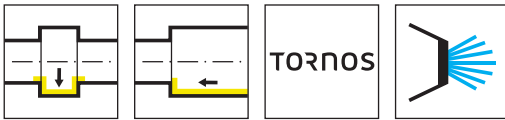

Numéro de commande Codice prodotto	$l_1$	$l_2$	$b_1$	$b$	$h$	$H_k$	$f_1$	$D_{a\max}$	HWS
<b>RKC760.0105.21</b>	57	24,9	40,9	14,2	29	18	26	28	105123 • 105124 • 105125
<b>RKC760.0105.41</b>	57	34,9	50,9	14,2	29	18	26	28	105123 • 105124 • 105125

Porte outils pour attacco base Tornos L760  
Portainseriti per base de support Tornos L760

### Pièces Détachées

Ricambi

Cassette Cartuccia	Vis de serrage Vite di serraggio	Tournevis TORX PLUS® Cacciavite TORX PLUS®
RKC760...	<b>5.12T20P</b>	<b>T15PQ</b>

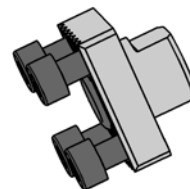
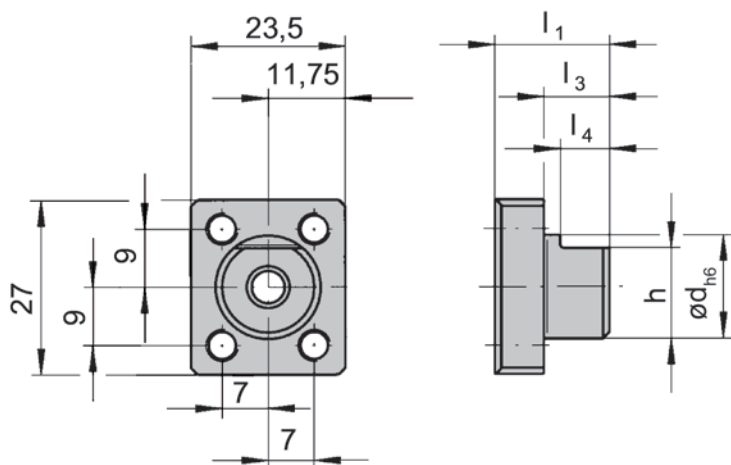
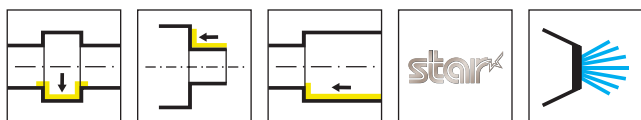

Numéro de commande Codice prodotto	h	d	$l_1$	$l_3$	$l_4$	Type de machine Tipo macchina	HMS
<b>BGT001.1627.10</b>	14	16	17,5	10	7,5	Star	Denture/Millerighe 90° / T3

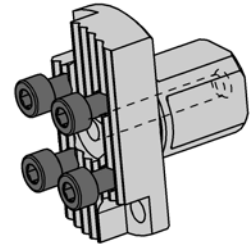
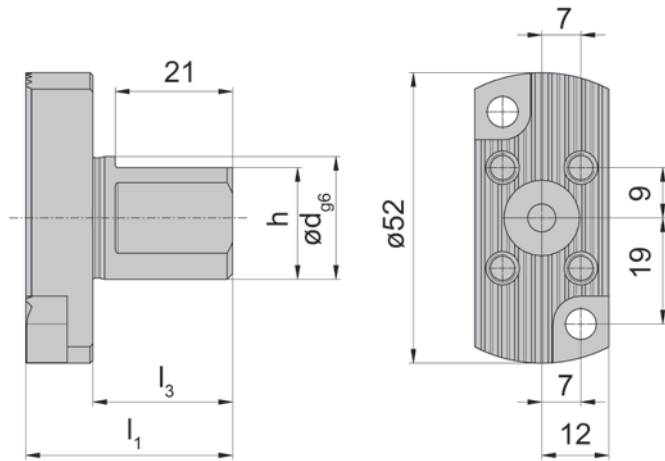
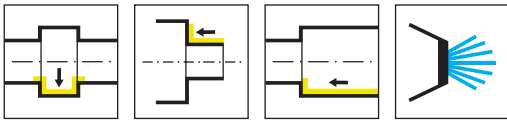

Numéro de commande Codice prodotto	h	d	l <sub>1</sub>	l <sub>3</sub>	l <sub>4</sub>	HMS
<b>BGT001.0R22.25</b>	20	22	37	25	21	Denture/Millerighe 90° / T3

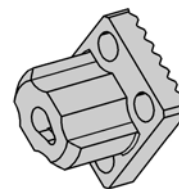
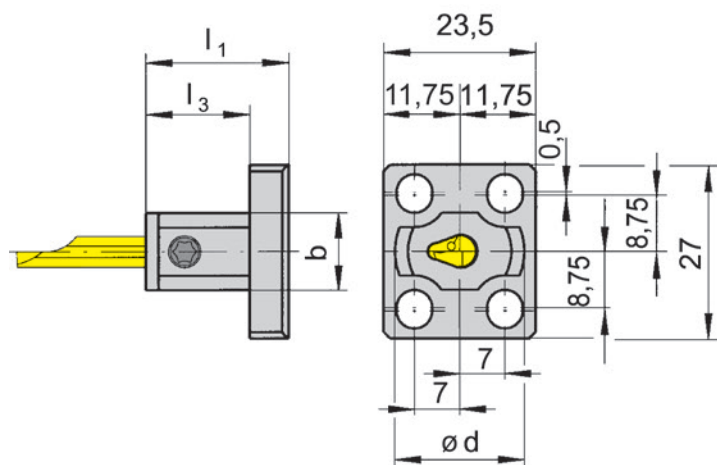
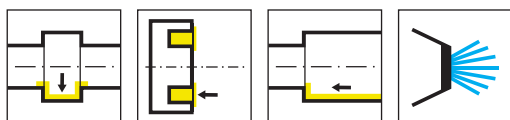

Numéro de commande Codice prodotto	d	l <sub>1</sub>	l <sub>3</sub>	b	HWS	HMS
<b>BKT105.2327.01</b>	20	22	16	12	105123 • 105124 • 105125	Denture/Millerighe 90° / T3

### Pièces Détachées

Ricambi

<b>Supports réglables</b> Portainsero registrabile	<b>Vis de serrage</b> Vite di serraggio	<b>Tournevis TORX PLUS®</b> Cacciavite TORX PLUS®
BKT105.2327.01	<b>6.075T15P</b>	<b>T15PQ</b>

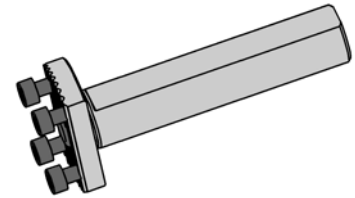
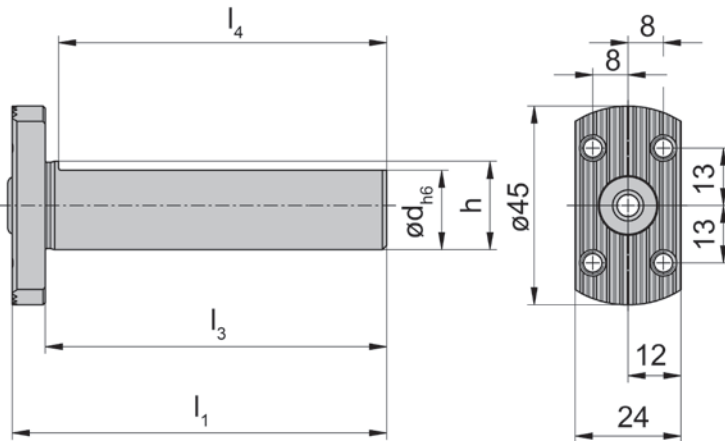
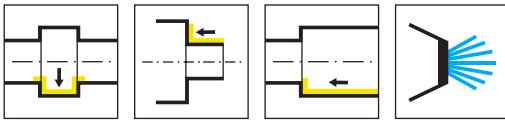

Numéro de commande Codice prodotto	h	d	l <sub>1</sub>	l <sub>3</sub>	l <sub>4</sub>	Type de machine Tipo macchina	HMS
<b>BGT001.0010.50</b>	9	10	57,5	50	47		Denture/Millierighe 90° / T3
<b>BGT001.0016.21</b>	14	16	28,5	21	18	Star	Denture/Millierighe 90° / T3
<b>BGT001.0R16.21</b>	14	16	28,5	21	18	Star	Denture/Millierighe 90° / T3
<b>BGT001.0020.100</b>	18	20	107,5	100	97	Tornos	Denture/Millierighe 90° / T3
<b>BGT001.0022.30</b>	20	22	36,35	30	27	Star	Denture/Millierighe 90° / T3
<b>BGT001.0025.70</b>	23	25	77,5	70	67		Denture/Millierighe 90° / T3

### BGT001.0022.30 sans arrosage au centre

BGT001.0022.30 senza foro per la lubrificazione interna

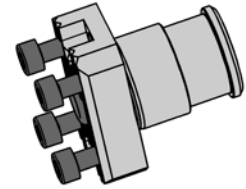
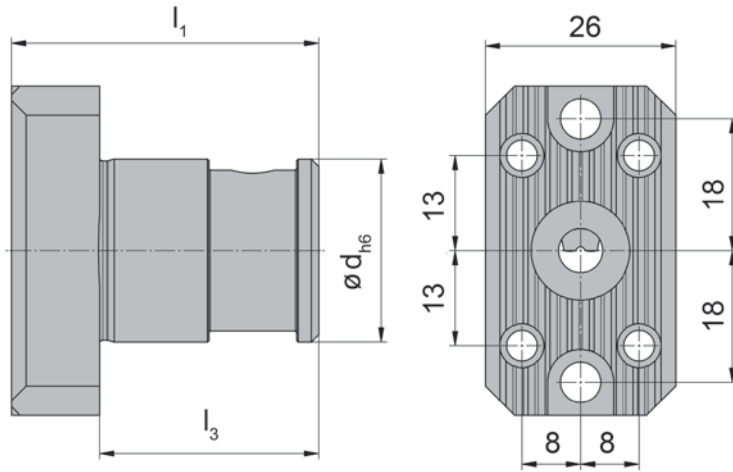
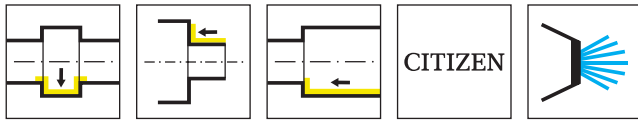

Numéro de commande Codice prodotto	d	$l_1$	$l_3$	Type de machine Tipo macchina	HMS
<b>BGT001.C025.30IK</b>	25	42	30	Citizen L20X	Denture/Millierighe 90° / T3

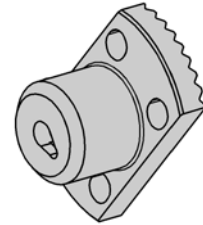
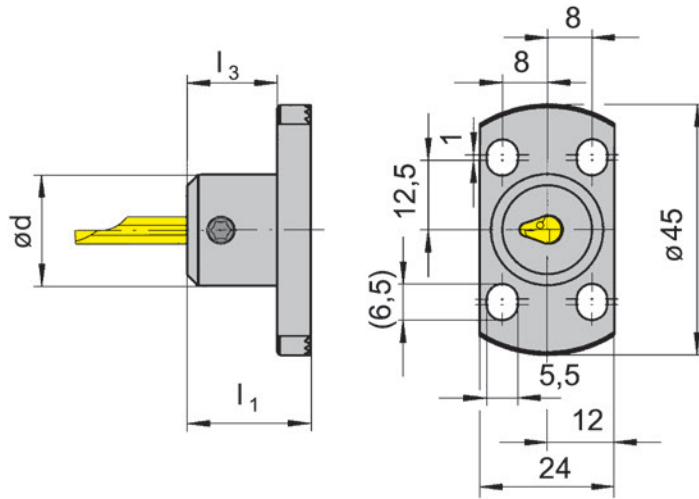
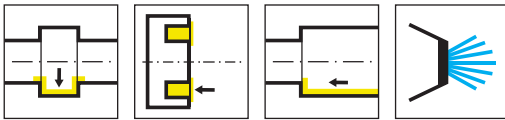

Numéro de commande Codice prodotto	d	l <sub>1</sub>	l <sub>3</sub>	HWS	HMS
<b>BKT105.2445.01</b>	20	22	16	105123 • 105124 • 105125	Denture/Millerighe 90° / T3
<b>BKT105.2445.02</b>	20	32	26	105225	Denture/Millerighe 90° / T3

## Pièces Détachées

Ricambi

Supports réglables Portainsero registrabile	Vis de serrage Vite di serraggio	Tournevis TORX PLUS® Cacciavite TORX PLUS®
BKT105...	<b>6.075T15P</b>	<b>T15PQ</b>

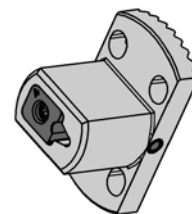
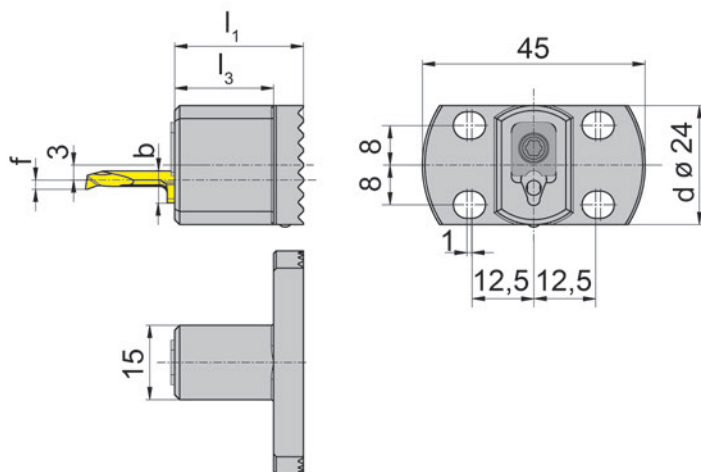
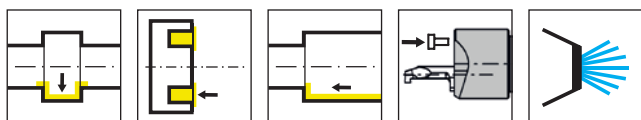

Numéro de commande Codice prodotto	$l_1$	d	$l_3$	b	HWS	HMS
<b>BKT105.2445.S.03</b>	26	24	20	5,9	105123	Denture/Millierighe 90° / T3
<b>BKT105.2445.S.04</b>	26	24	20	6,4	105124	Denture/Millierighe 90° / T3
<b>BKT105.2445.S.05</b>	26	24	20	7	105125	Denture/Millierighe 90° / T3

f voir plaquettes type 105  
f vd. Inserti tipo 105

**Pièces Détachées**

Ricambi

Supports réglables Portainsero registrabile	Bride Staffa	Tournevis TORX PLUS® Cacciavite TORX PLUS®
BKT105.2445.S.03	<b>010.0105.03</b>	<b>T15PL</b>
BKT105.2445.S.04	<b>010.0105.04</b>	<b>T15PL</b>
BKT105.2445.S.05	<b>010.0105.05</b>	<b>T15PL</b>

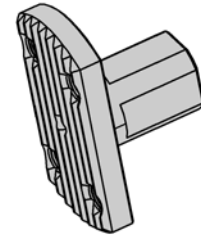
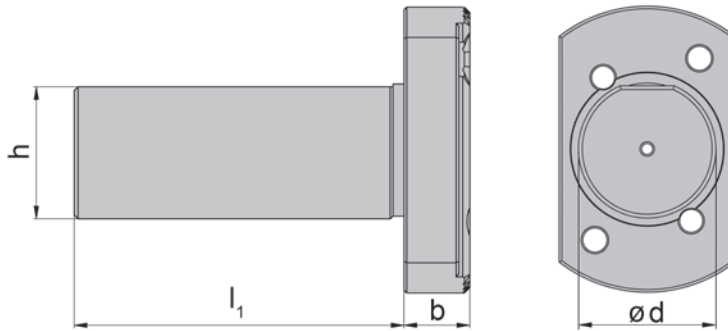
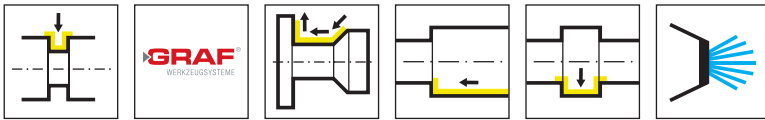

Número de commande Codice prodotto	d	l <sub>1</sub>	h	b	Type de machine Tipo macchina
G.016.021	16	21	14	6	Star
G.016.040	16	40	14	6	Traub/Manurhin
G.034.040	3/4"	40	18	6	Citizen
G.034.050	3/4"	50	18	6	Citizen
G.034.120	3/4"	120	18	6	Citizen
G.020.030	20	30	18	6	Citizen
G.020.040	20	40	18	6	Citizen
G.020.100	20	100	18	6	Citizen
G.020.150	20	150	18	6	Citizen
G.022.023	22	23	20	6	Star
G.022.030	22	30	20	6	Star
G.022.070	22	70	20	6	Star
G.025.060	25	60	23	12	Hanwha
G.025.070	25	70	23	6	Manurhin/Tornos
G.025.100	25	100	23	6	Manurhin/Tornos
G.025.160	25	160	23	6	Manurhin/Tornos
G.010.060	1"	60	23	6	Citizen
G.010.100	1"	100	23	6	Citizen
G.028.006	28	6	26	6	Hanwha
G.028.080	28	80	26	12	Traub
G.034.020	34	20	32	12	Maier
G.034.044	34	44	32	12	Maier/Hanwha

Dimensions en pouce et mm  
Dimensioni in pollici e mm

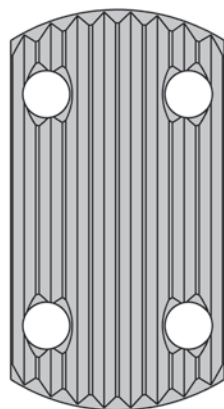

**A**

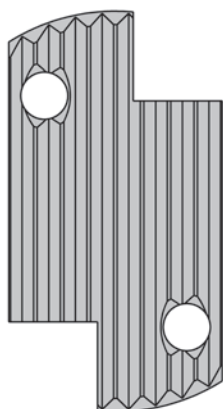

**B**

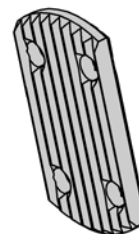
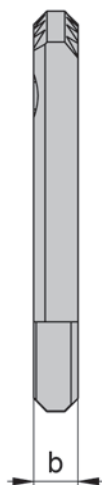

Numéro de commande Codice prodotto	b	Forme Forma
<b>Z.5</b>	5	A
<b>Z.10</b>	10	A
<b>Z.15</b>	15	A
<b>Z.20</b>	20	A
<b>Z.25</b>	25	A
<b>Z.30</b>	30	A
<b>Z10SR16/20R</b>	10	B
<b>Z25SR16/20R</b>	25	B
<b>Z30SR16/20R</b>	30	B



### **pour contre broche** per lavorazione su contro mandrino

pour supports de porte outils Graf Type N, HORN BKT105.2445.01/02 et BKT105.2445.S.03/04/05  
per portainseriti Graf tipo N, HORN BKT105.2445.01/02 e BKT105.2445.S.03/04/05

**N° de commande N11**  
Codice prodotto

Alternative pour 2 cartouches  
N. 2 portainseriti a scelta

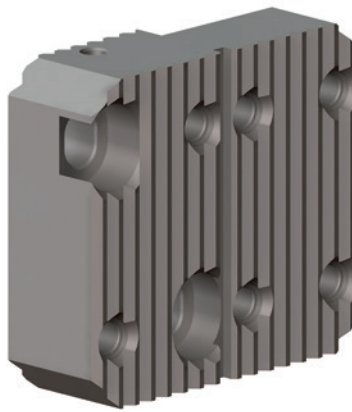

**N° de commande N12**  
Codice prodotto

Alternative pour 3 cartouches  
N. 3 portainseriti a scelta

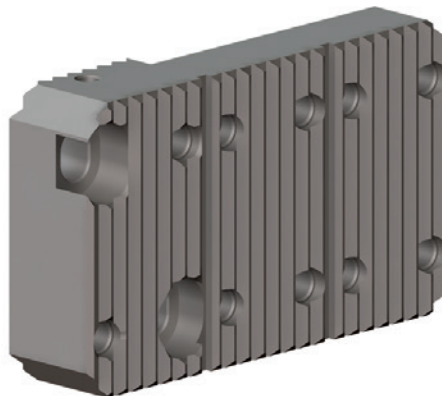

**N° de commande N93IK**  
Codice prodotto

avec arrosage central  
con foro per la lubrificazione interna

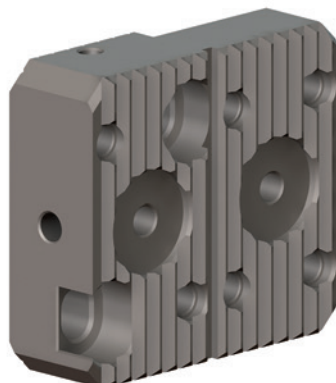

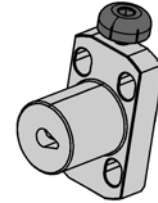
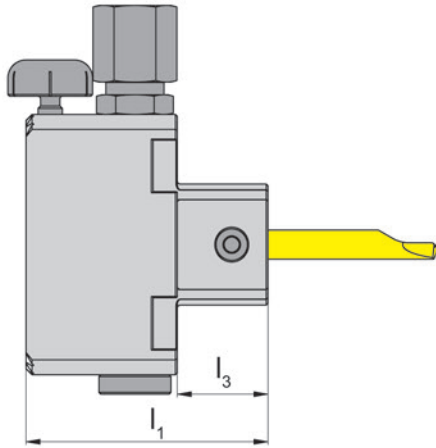
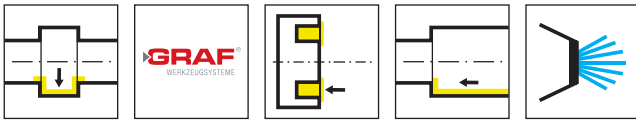

Illustration de coupe à droite représentée  
Figura = taglio destro

Numéro de commande Codice prodotto	$l_1$	$l_3$	HWS
<b>N.09.IK</b>	40	15	105123 • 105124 • 105125

Le raccord du liquide de coupe ne fait pas partie de la référence . Merci de le commander séparément.  
L'adduttore del refrigerante va ordinato separatamente!

## Pièces Détachées

Ricambi

Supports réglables Portainsero registrabile	Vis de serrage Vite di serraggio	Arrosage Lubrificazione
N.09.IK	<b>6.075T15P</b>	<b>004.00.19</b>

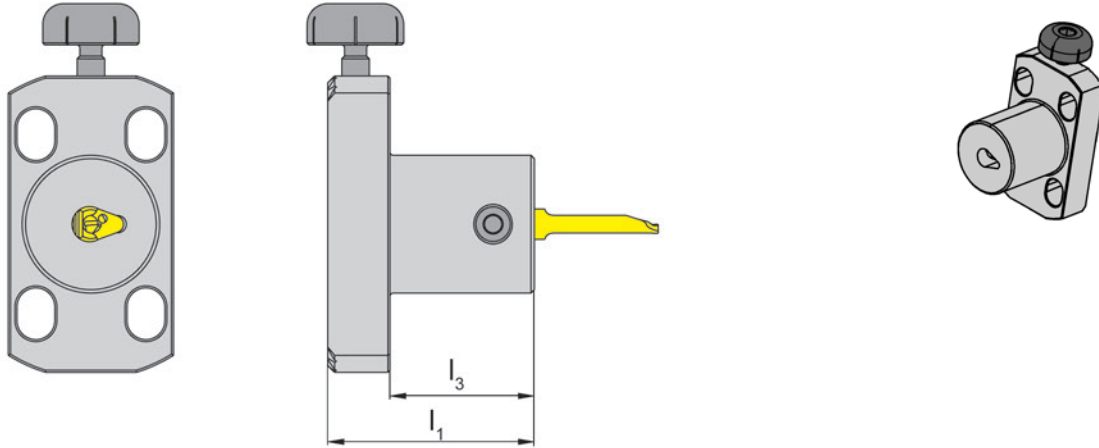
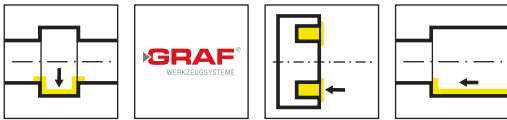

Illustration de coupe à droite représentée

Figura = taglio destro

Numéro de commande Codice prodotto	$l_1$	$l_3$	HWS
<b>N.09</b>	30	20	105123 • 105124 • 105125

### Pièces Détachées

Ricambi

Supports réglables Portainsero registrabile	Vis de serrage Vite di serraggio
N.09	<b>6.075T15P</b>

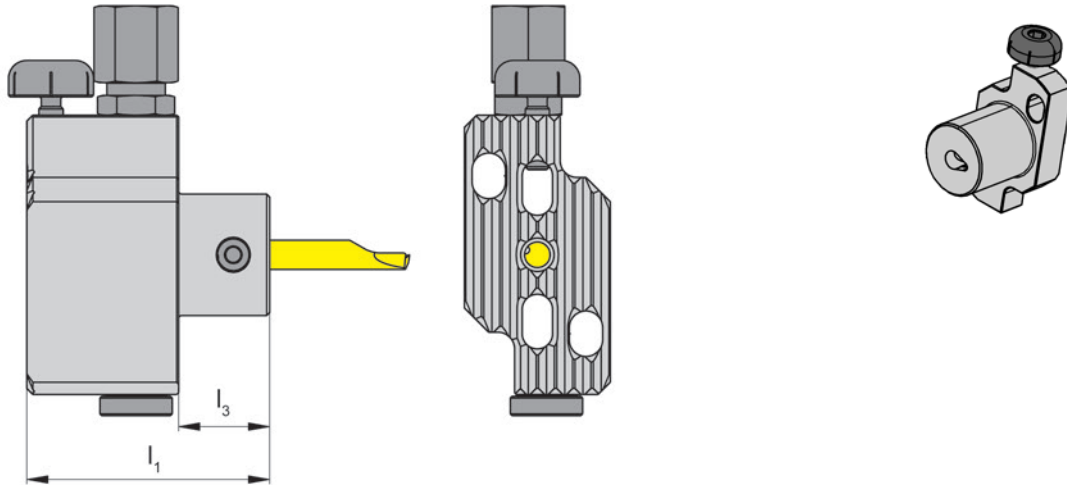
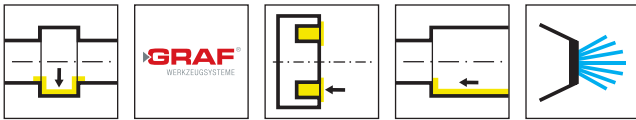

Illustration de coupe à droite représentée  
Figura = taglio destro

Numéro de commande Codice prodotto	$l_1$	$l_3$	HWS
<b>N.73.IK</b>	40	15	105123 • 105124 • 105125

Le raccord du liquide de coupe ne fait pas partie de la référence . Merci de le commander séparément.  
L'adduttore del refrigerante va ordinato separatamente!

**Pièces Détachées**

Ricambi

Supports réglables Portainsero registrabile	Vis de serrage Vite di serraggio	Arrosage Lubrificazione
N.73.IK	<b>6.075T15P</b>	<b>004.00.19</b>

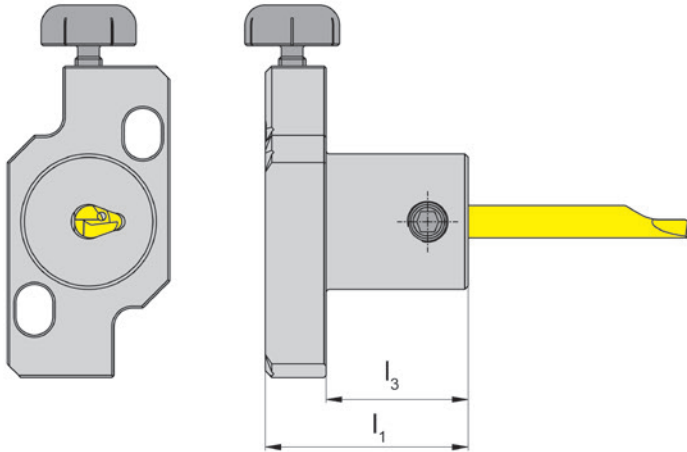
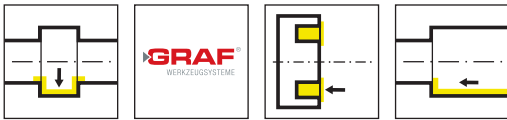

Illustration de coupe à droite représentée  
Figura = taglio destro

Numéro de commande Codice prodotto	$l_1$	$l_3$	HWS
<b>N.73</b>	30	20	105123 • 105124 • 105125

## Pièces Détachées

Ricambi

Supports réglables Portainserto registrabile	Vis de serrage Vite di serraggio
N.73	<b>6.075T15P</b>

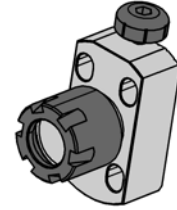
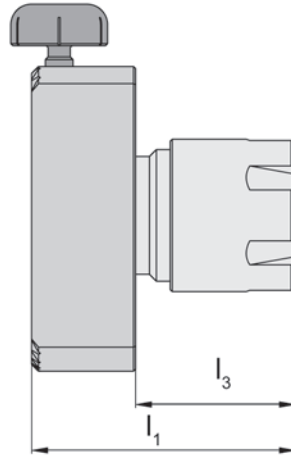
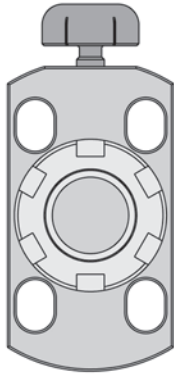

Numéro de commande Codice prodotto	$l_1$	$l_3$	Baguette de serrage Ghiera di bloccaggio
N.07	37	18	ER16

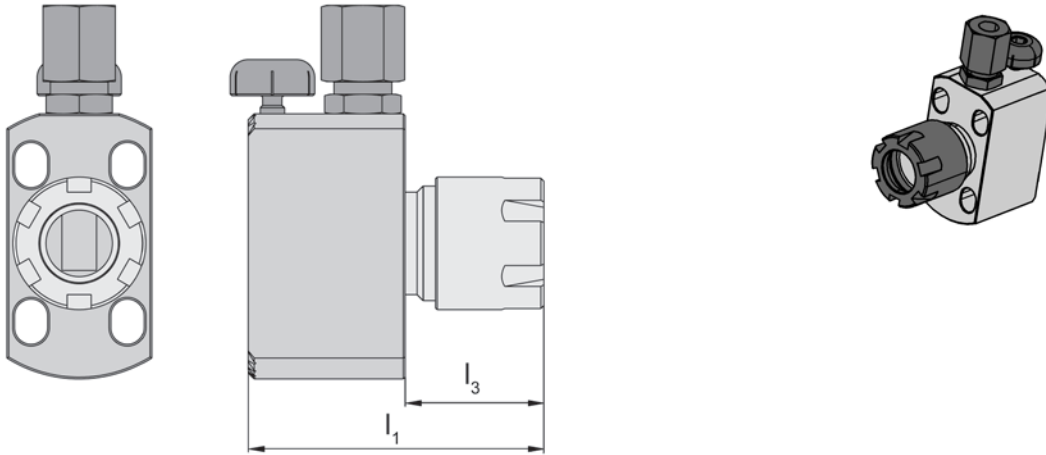
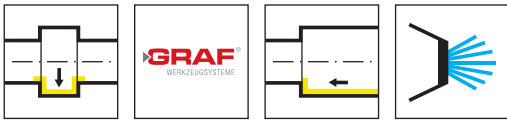

Numéro de commande Codice prodotto	$l_1$	$l_3$	Bague de serrage Ghiera di bloccaggio
<b>N.07.IK</b>	54	18	ER16
<b>N.41.IK</b>	64	26	ER20

Le raccord du liquide de coupe ne fait pas partie de la référence . Merci de le commander séparément.  
L'adduttore del refrigerante va ordinato separatamente!

## Pièces Détachées

Ricambi

Supports réglables Portainsero registrabile	Arrosage Lubrificazione
N...	<b>004.00.19</b>

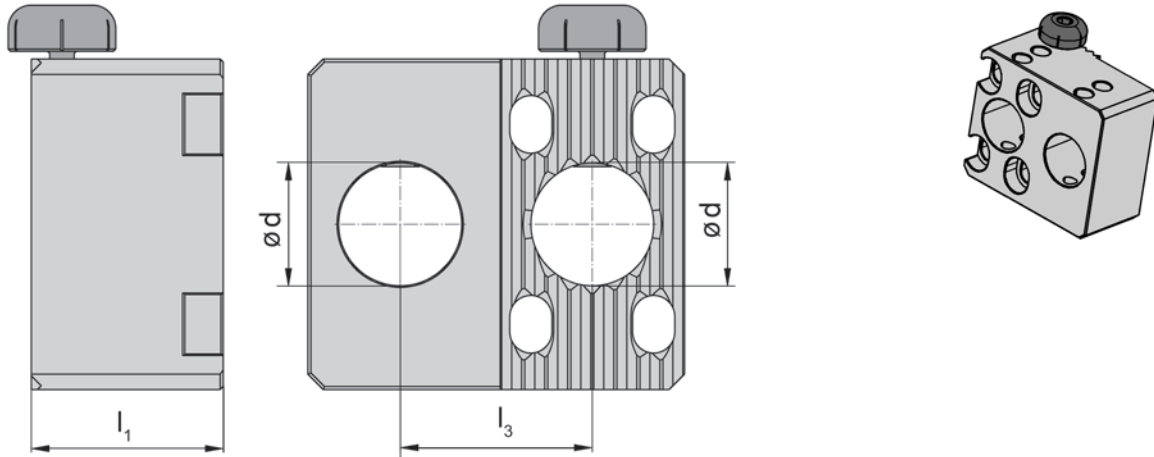

Numéro de commande Codice prodotto	d	l <sub>1</sub>	l <sub>3</sub>
<b>N.10</b>	16	25	25

L'écrou de serrage n'est pas inclus - passer une commande séparément!  
Gli adattatori per pinze non sono inclusi - ordinare separatamente!

### Raccord pour arrosage centre outils pour tuyau Ø 6 mm

Raccordi per l'adduzione del refrigerante per tubo Ø 6 mm



Raccord pour arrosage centre outils, directement vissé  
Raccordo ad angolo,  
Raccordo diritto

N° de commande	A	B
Codice prodotto		
004.00.19	M8 x 1	Ø 6 mm
004.00.14	G1/8"	Ø 6 mm

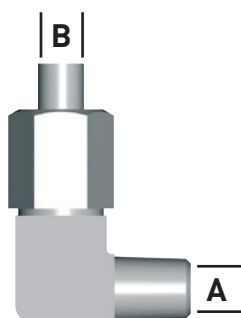

Raccord pour arrosage centre outils, Coudé et fixe  
Raccordo ad angolo,  
Raccordo ad angolo, non orientabile

N° de commande	A	B
Codice prodotto		
004.00.22	M8 x 1	Ø 6 mm
004.00.33	G1/8"	Ø 6 mm

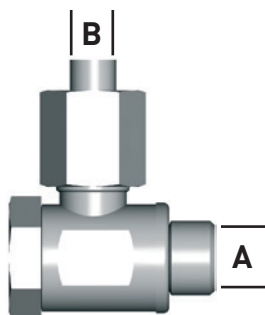

Raccord à vissé pivotant  
Raccordo ad angolo orientabile

N° de commande	A	B
Codice prodotto		
004.00.61	M8 x 1	Ø 6 mm
004.00.16	G1/8"	Ø 6 mm

### Raccord rapide pour arrosage centre outils

Raccordo ad innesto rapido per l'adduzione del refrigerante

Raccord rapide  
Innesto rapido

M10 x 1 - 004.00.49

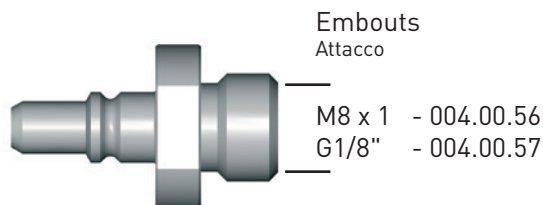
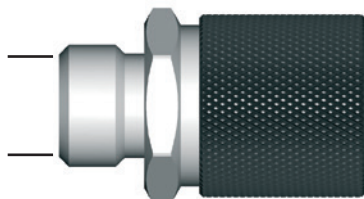

Embouts  
Attacco

M8 x 1 - 004.00.56  
G1/8" - 004.00.57

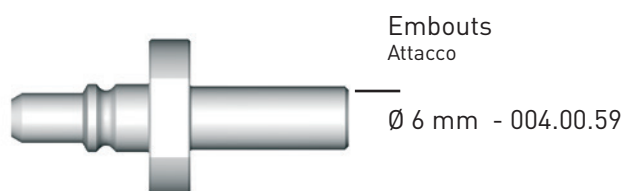

Embouts  
Attacco

Ø 6 mm - 004.00.59

## Bague de serrage

Ghiera di bloccaggio



ER-M

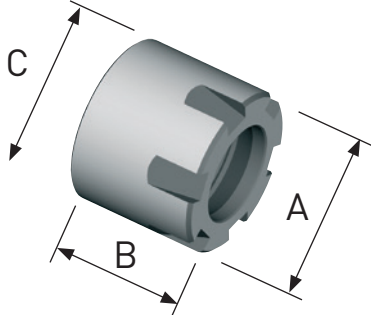

ER-M	A	B	C
62 000 08-ER 8	12	10,8	M10x0,75
62 000 11-ER 11	16	12	M13x0,75
62 000 16-ER 16	22	18	M19x1
62 000 20-ER 20	28	19	M24x1
62 000 25-ER 25	35	20	M30x1

ER-MA pour rondelles d'étanchéité a tenuta stagna

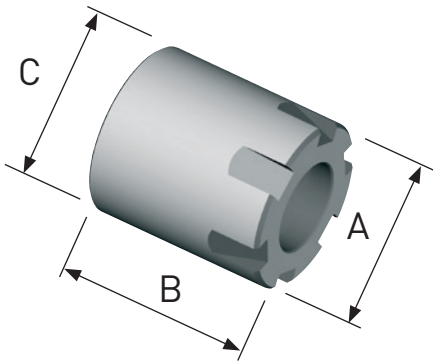

ER-MA	A	B	C
62 600 16-ER 16	22	24,5	M19x1
62 600 20-ER 20	28	26,5	M24x1
62 600 25-ER 25	35	27,5	M30x1

Rondelles d'étanchéité pour bague de serrage ER-MA...

Anello di tenuta per ghiera di bloccaggio

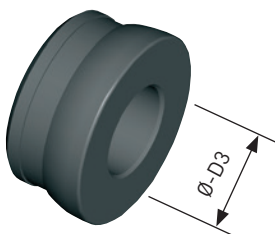

Série complète:  
Set completo:

N° de commande Codice prodotto	Ø D3
64 600 16-ER 16	3,0-3,5...9,5-10,0 mm
64 600 20-ER 20	3,0-3,5...12,5-13,0 mm
64 600 25-ER 25	3,0-3,5...15,5-16,0 mm

Les rondelles peuvent être commandées séparément.  
Gli anelli di tenuta possono anche essere ordinati separatamente.

Exemple:

Esempio:

N° de commande Codice prodotto	Plage de diamètre Gamma diametri	possible de-jusqu'à possibile da-fino a
ER 16 64 600 16 <b>30</b>	3,01 - 3,50	3 - 10
ER 20 64 600 20 <b>45</b>	4,51 - 5,00	3 - 13
ER 25 64 600 25 <b>80</b>	8,01 - 8,50	3 - 16

# Appareil de réglage en hauteur

Apparecchio per la pre-regolazione degli utensili in altezza

HVR.40

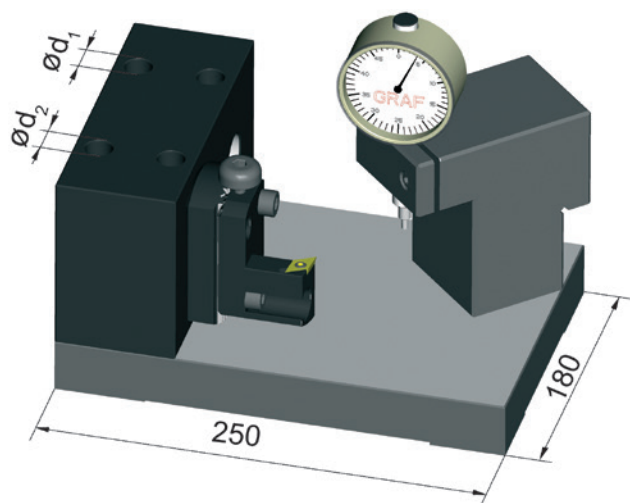
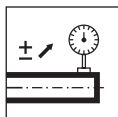

Numéro de commande Codice prodotto	$d_1$	$d_2$	Type de machine Tipo macchina
HVR.40.16.22	16	22	Star
HVR.40.20.22	20	22	Star
HVR.40.20.25	20	25	Tornos
HVR.40.20.28	20	28	Hanwha
HVR.40.25.28	25	28	Hanwha
HVR.40.25.33	25	33	Hanwha
HVR.40.25.34	25	34	Hanwha
HVR.40.30.34	30	34	Maier
HVR.40.34.10	3/4"	1"	Citizen

Dimensions en pouce et mm  
Dimensioni in pollici e mm

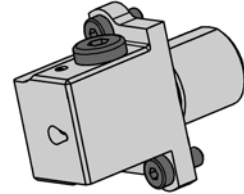
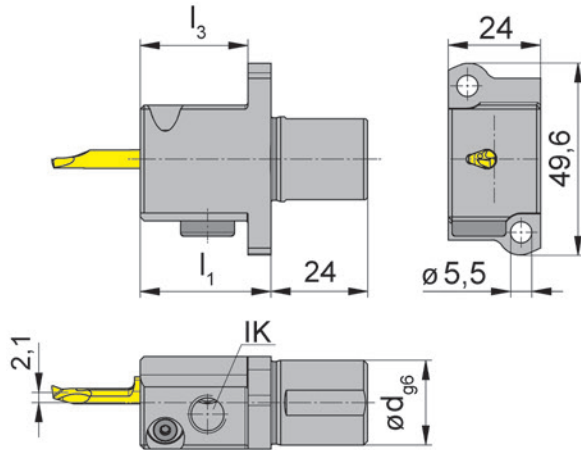
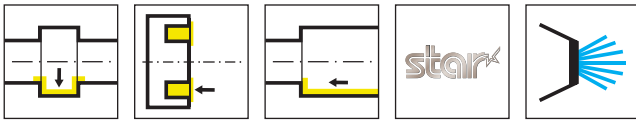

L = version à gauche  
L = versione sinistra

Numéro de commande Codice prodotto	d	l <sub>1</sub>	l <sub>3</sub>	HWS	HMS
<b>LB105.A022.26.31</b>	22	35	29	105123 • 105124 • 105125	Star

Machines types suisse Star:

ECAS-12/20, SB16D/E, SR-20, SR20J/JN, RS-20RII, RS-20RIII, RS-20RIV, RS-32J/JN, SW-12RII

Macchine fantina mobile Star:

ECAS-12/20, SB16D/E, SR-20, SR20J/JN, RS-20RII, RS-20RIII, RS-20RIV, RS-32J/JN, SW-12RII

### Pièces Détachées

Ricambi

Porte outils Portainsero	Tournevis TORX PLUS® Cacciavite TORX PLUS®	Vis Vite
LB105.A022.26.31	<b>T10PL</b>	<b>18.908</b>

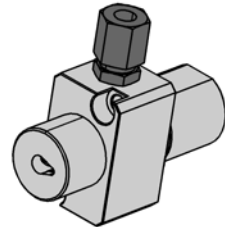
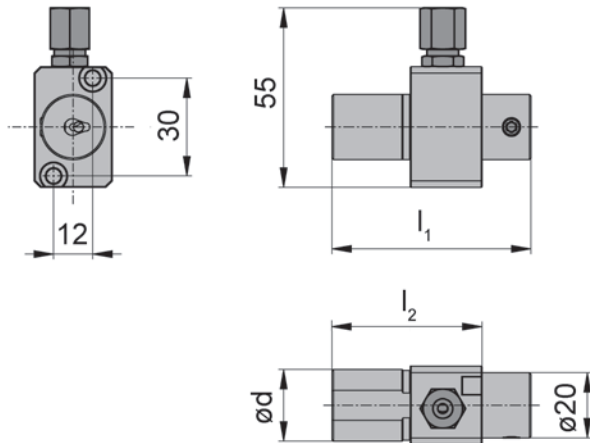
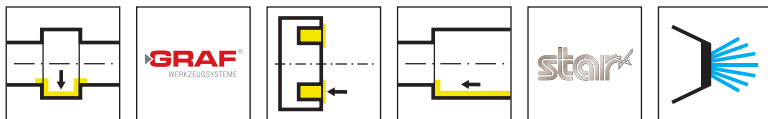

Numéro de commande Codice prodotto	d	l <sub>1</sub>	l <sub>2</sub>	HWS
<b>RHF.N.145.H105.S1.IK</b>	22	61	46	105123 • 105124 • 105125

Machines types suisse Star: SW-20  
 Macchine fantina mobile Star: SW-20

Le raccord du liquide de coupe ne fait pas partie de la référence . Merci de le commander séparément.  
 L'adduttore del refrigerante va ordinato separatamente!

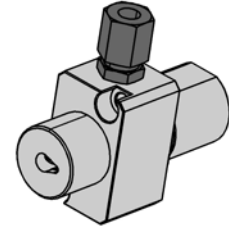
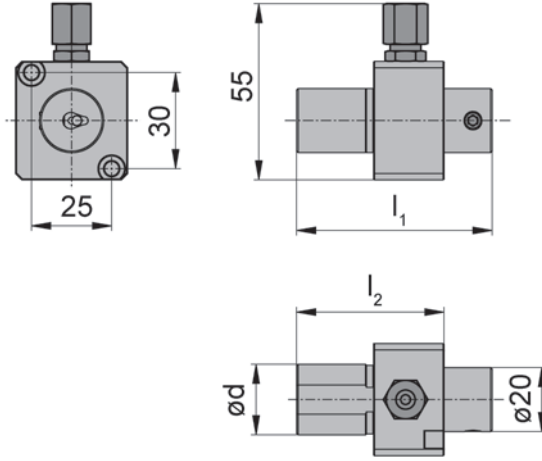
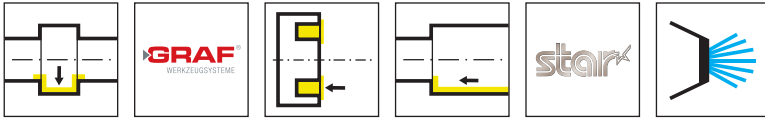

Numéro de commande Codice prodotto	d	l <sub>1</sub>	l <sub>2</sub>	HWS
<b>RHF.N.151.H105.S2.IK</b>	22	61	46	105123 • 105124 • 105125

Machines types suisse Star: SW-20  
Macchine fantina mobile Star: SW-20

Le raccord du liquide de coupe ne fait pas partie de la référence . Merci de le commander séparément.  
L'adduttore del refrigerante va ordinato separatamente!

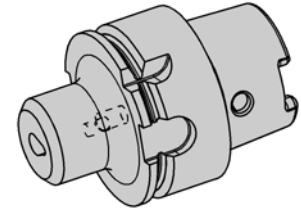
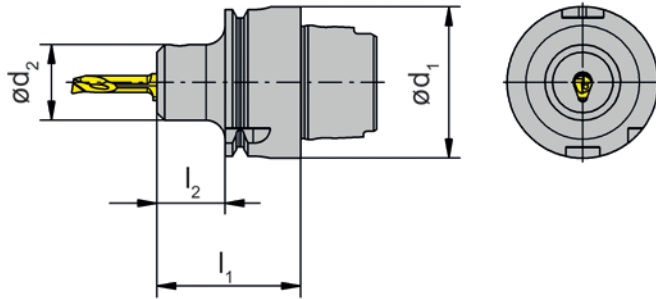
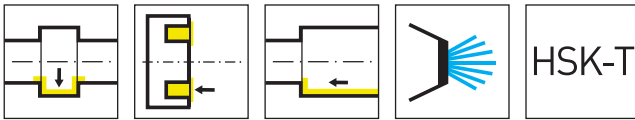

R = version à droite représentée  
R = versione destra come in figura

L = version à gauche  
L = versione sinistra a specchio

Numéro de commande Codice prodotto	$d_1$	$l_1$	$l_2$	$d_2$	HWS
<b>HSKT40.RB105.20.1.01</b>	40	38	18	20	105123 • 105124 • 105125

### Pièces Détachées

Ricambi

Porte outils Portainsero	Vis de serrage Vite di serraggio	Tournevis TORX PLUS® Cacciavite TORX PLUS®
HSKT40...	<b>6.075T15P</b>	<b>T15PQ</b>

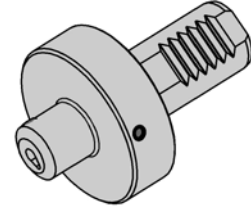
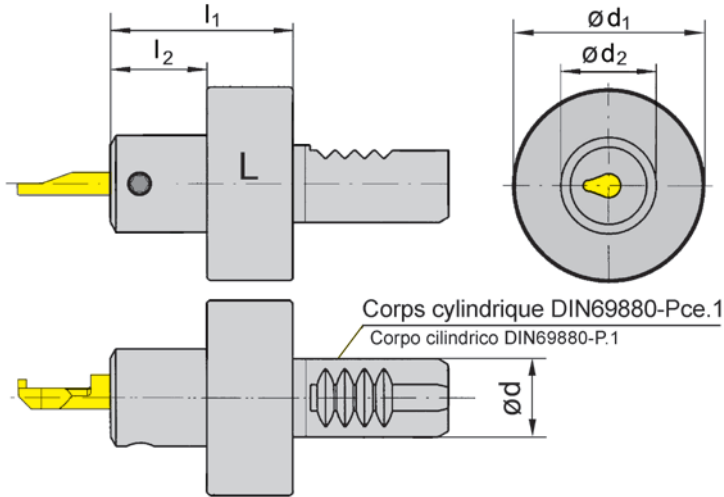
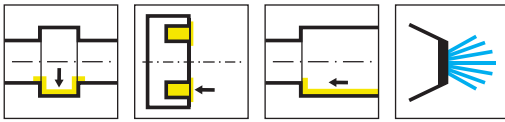

L = version à gauche représentée  
L = versione sinistra come in figura

R = version à droite  
R = versione destra a specchio

Numéro de commande Codice prodotto	d	l <sub>1</sub>	l <sub>2</sub>	d <sub>2</sub>	d <sub>1</sub>	HWS
VDI16.R105.20.01	16	38	20	20	40	105123 • 105124 • 105125
VDI20.R105.20.01	20	38	20	20	50	105123 • 105124 • 105125
VDI25.R105.20.01	25	38	20	20	58	105123 • 105124 • 105125
VDI30.R105.20.01	30	38	20	20	68	105123 • 105124 • 105125
VDI40.R105.20.01	40	38	20	20	83	105123 • 105124 • 105125
VDI16.L105.20.01	16	38	20	20	40	105123 • 105124 • 105125
VDI20.L105.20.01	20	38	20	20	50	105123 • 105124 • 105125
VDI25.L105.20.01	25	38	20	20	58	105123 • 105124 • 105125
VDI30.L105.20.01	30	38	20	20	68	105123 • 105124 • 105125
VDI40.L105.20.01	40	38	20	20	83	105123 • 105124 • 105125

### Pièces Détachées

Ricambi

Porte outils Portainsero	Vis de serrage Vite di serraggio	Tournevis TORX PLUS® Cacciavite TORX PLUS®
VDI16...	6.075T15P	T15PQ

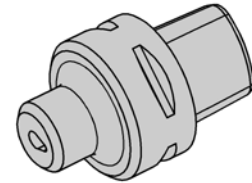
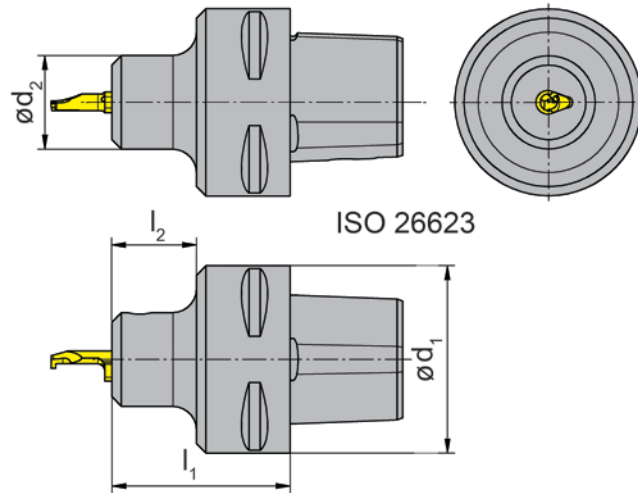
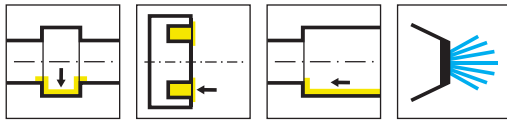

R = version à droite représentée  
R = versione destra come in figura

L = version à gauche  
L = versione sinistra a specchio

Numéro de commande Codice prodotto	$d_1$	$d_2$	$l_1$	$l_2$	HWS
<b>RB105.00C3.20.1.01</b>	32	20	30	15	105123 • 105124 • 105125
<b>RB105.00C4.20.1.01</b>	40	20	38	18	105123 • 105124 • 105125
<b>RB105.00C5.20.1.01</b>	50	20	38	18	105123 • 105124 • 105125
<b>RB105.00C6.20.1.01</b>	63	20	52	30	105123 • 105124 • 105125
<b>LB105.00C3.20.1.01</b>	32	20	30	15	105123 • 105124 • 105125
<b>LB105.00C4.20.1.01</b>	40	20	38	18	105123 • 105124 • 105125
<b>LB105.00C5.20.1.01</b>	50	20	38	18	105123 • 105124 • 105125
<b>LB105.00C6.20.1.01</b>	63	20	52	30	105123 • 105124 • 105125

### Pièces Détachées

Ricambi

Porte outils Portainsero	Vis de serrage Vite di serraggio	Tournevis TORX PLUS® Cacciavite TORX PLUS®
R/LB105...	<b>6.075T15P</b>	<b>T15PQ</b>

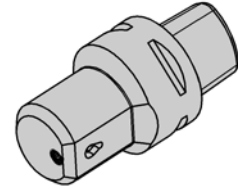
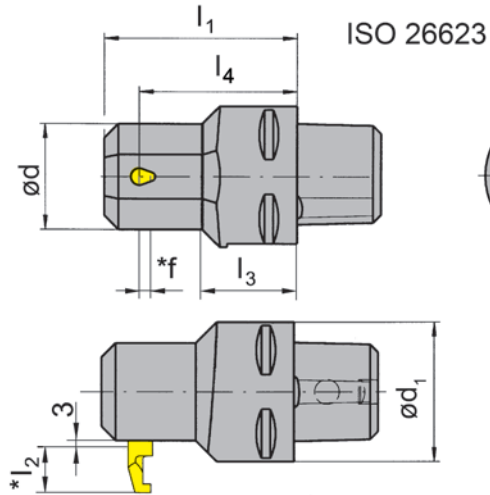
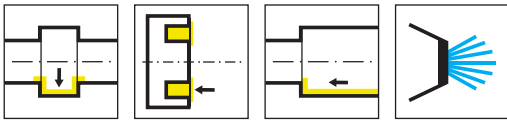

Numéro de commande Codice prodotto	d <sub>1</sub>	l <sub>3</sub>	d	l <sub>1</sub>	l <sub>4</sub>	b <sub>1</sub>	HWS
RB105.00C3.2.2.01	32	17	30	55	45	14	105123 • 105124 • 105125
RB105.00C3.2.2.02	32	15	36	55	45	18	105123 • 105124 • 105125
RB105.00C4.2.2.01	40	26	30	55	45	14	105123 • 105124 • 105125
RB105.00C4.2.2.02	40	22	36	55	45	18	105123 • 105124 • 105125

f, l2 voir plaquette type 105  
f, l2 vd. inserto tipo 105

**Pièces Détachées**

Ricambi

Porte outils Portainsero	Vis de serrage Vite di serraggio	Tournevis TORX PLUS® Cacciavite TORX PLUS®
RB105...	6.075T15P	T15PQ

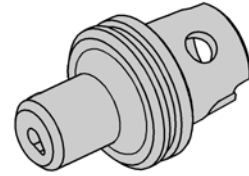
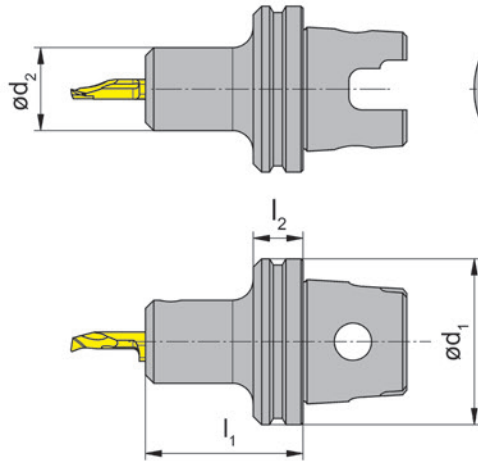
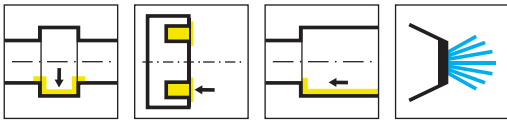

R = version à droite représentée  
R = versione destra come in figura

L = version à gauche  
L = versione sinistra a specchio

Numéro de commande Codice prodotto	$d_1$	$d_2$	$l_1$	$l_2$	HWS
<b>RB105.TS40.20.1.01</b>	40	20	38	26	105123 • 105124 • 105125
<b>LB105.TS40.20.1.01</b>	40	20	38	26	105123 • 105124 • 105125

### Pièces Détachées

Ricambi

Porte outils Portainsero	Vis de serrage Vite di serraggio	Tournevis TORX PLUS® Cacciavite TORX PLUS®
R/LB105.TS40.20.1.01	<b>6.075T15P</b>	<b>T15PQ</b>

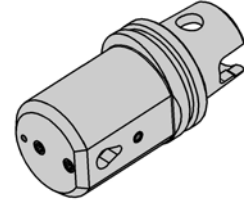
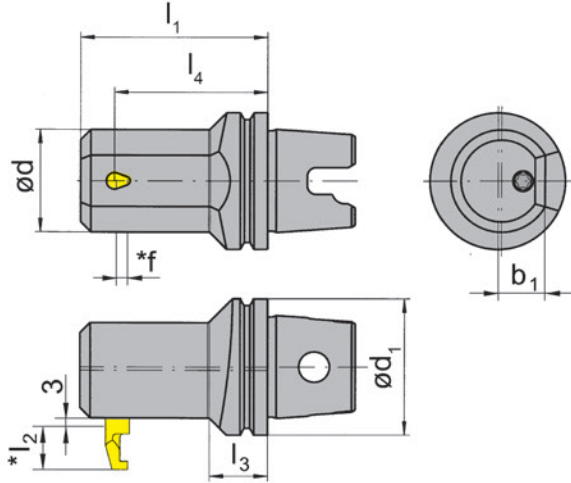
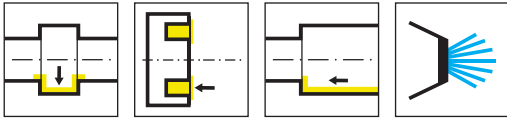

R = version à droite représentée  
R = versione destra come in figura

L = version à gauche  
L = versione sinistra a specchio

Numéro de commande Codice prodotto	d <sub>1</sub>	l <sub>3</sub>	d	l <sub>1</sub>	l <sub>4</sub>	b <sub>1</sub>	HWS
RB105.TS40.2.2.01	40	17	30	55	45	14	105123 • 105124 • 105125
RB105.TS40.2.2.02	40	14	36	55	45	18	105123 • 105124 • 105125
RB105.TS50.2.2.01	50	26	30	55	45	14	105123 • 105124 • 105125
RB105.TS50.2.2.02	50	22	36	55	45	18	105223 • 105224 • 105225

Pièces Détachées

Ricambi

Porte outils Portainsero	Vis de serrage Vite di serraggio	Tournevis TORX PLUS® Cacciavite TORX PLUS®
RB105...	6.075T15P	T15PQ

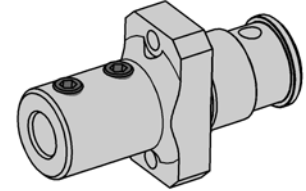
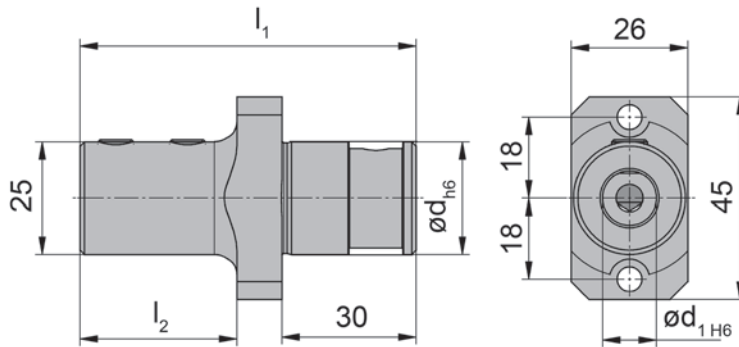
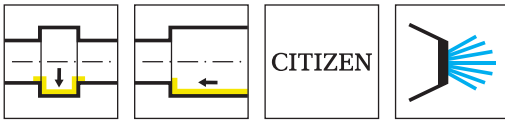

Numéro de commande Codice prodotto	d	$l_1$	$d_1$	$l_2$	Type de machine Tipo macchina
001.C025.12.30IK	25	75	12	35	Citizen L20X/

## Pièces Détachées

Ricambi

Adaptateur Adattatore	Vis de serrage Vite di serraggio
001.C025.12.30IK	8.075.1835

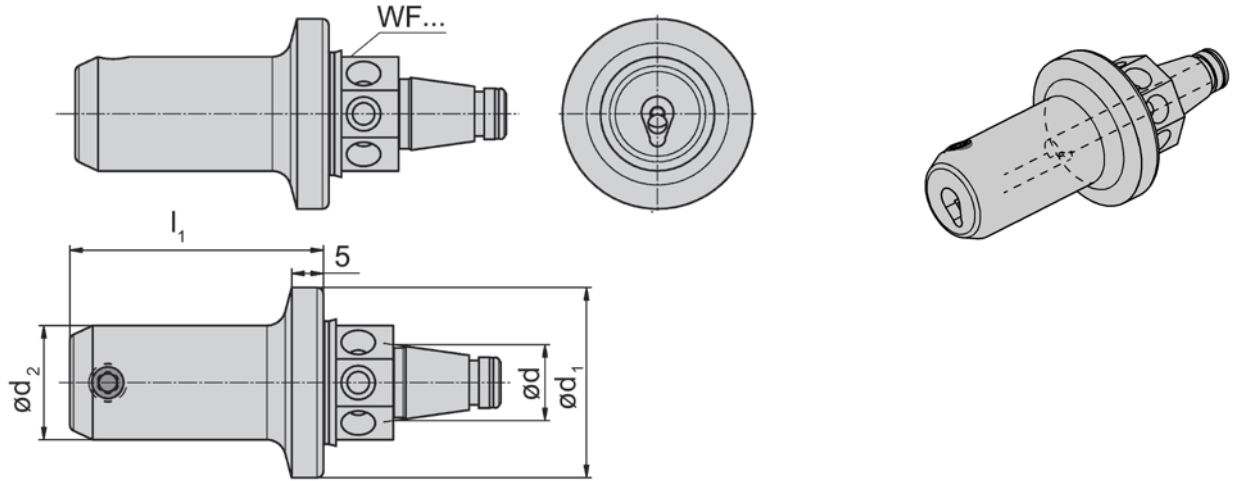
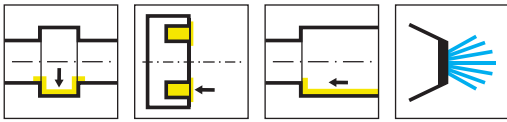

Numéro de commande Codice prodotto	d <sub>1</sub>	l <sub>1</sub>	d	d <sub>2</sub>	HWS	HMS
WFB.2HO.105	30	40	12	18	105123 • 105124 • 105125	WFB
WFB.2HO.105.055	30	55	12	18	105123 • 105124 • 105125	WFB
WFB.3HO.105	50	40	20	18	105123 • 105124 • 105125	WFB
WFB.3HO.105.055	50	55	20	18	105123 • 105124 • 105125	WFB

Pièces Détachées

Ricambi

Porte outils Portainsero	Vis de serrage Vite di serraggio	Tournevis TORX PLUS® Cacciavite TORX PLUS®
WFB...	6.075T15P	T15PQ

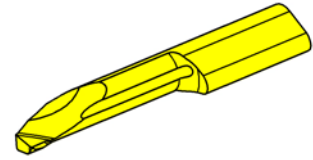
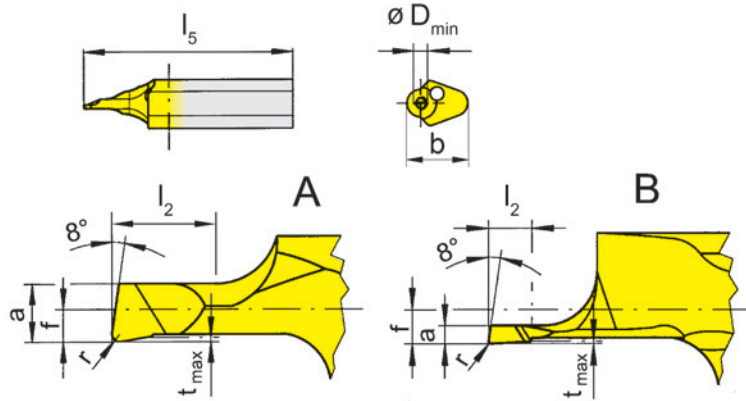
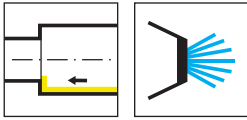

R = version à droite représentée  
R = versione destra come in figura

L = version à gauche  
L = versione sinistra a specchio

▲ en stock  
a stock

Nuance  
Leghe  
Δ 4 semaines  
4 settimane

Numéro de commande Codice prodotto	r	f	a	b	l <sub>2</sub>	l <sub>5</sub>	t <sub>max</sub>	D <sub>min</sub>	Forme Forma	HIS	Nuance Leghe	
											EG35	IG35
R105.1802.0.02	0,02	1	0,17	5,9	1	23	0,02	0,2	B	105123	Δ	-
R105.1802.0.03	0,02	1	0,25	5,9	1	23	0,02	0,3	B	105123	Δ	-
R105.1802.0.05	0,05	1	0,4	5,9	2	23	0,05	0,5	B	105123	▲	▲
R105.1803.0.07	0,05	0,3	0,6	5,9	2	23	0,05	0,7	A	105123	▲	▲
L105.1802.0.02	0,02	1	0,17	5,9	1	23	0,02	0,2	B	105123	Δ	-
L105.1802.0.03	0,02	1	0,25	5,9	1	23	0,02	0,3	B	105123	Δ	-
L105.1802.0.05	0,05	1	0,4	5,9	2	23	0,05	0,5	B	105123	Δ	-
L105.1803.0.07	0,05	0,3	0,6	5,9	2	23	0,05	0,7	A	105123	Δ	-
											P	● -
											M	● ●
											K	o -
											N	- -
											S	- ●
											H	- -

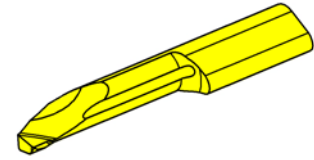
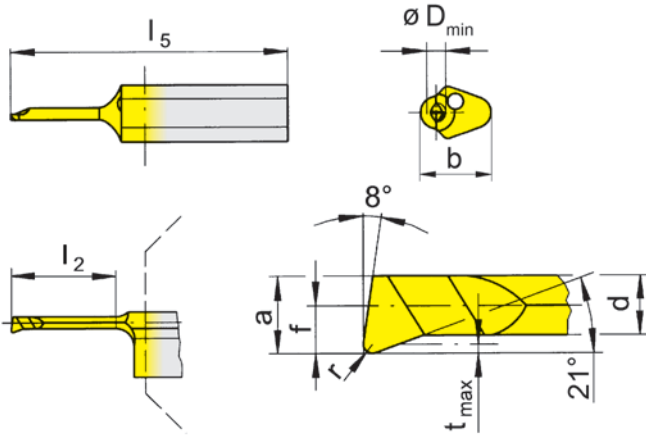
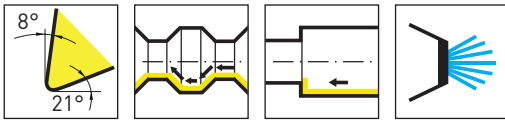

R = version à droite représentée  
R = versione destra come in figura

L = version à gauche  
L = versione sinistra a specchio

▲ en stock  
a stock

Nuance  
Leghe  
Δ 4 semaines  
4 settimane

Numéro de commande Codice prodotto	r	f	a	d	b	l <sub>2</sub>	l <sub>5</sub>	t <sub>max</sub>	D <sub>min</sub>	HIS	Nuance / Leghe				
											EG35	IG35	TH35	TI25	TN35
R105.1805.005.0.1	0,05	0,5	0,9	0,65	5,9	4	25	0,1	1	105123	▲	▲	▲		
R105.1805.005.1.1	0,05	0,5	0,9	0,65	5,9	6	25	0,1	1	105123	▲	▲	▲		
R105.1805.005.2.1	0,05	0,5	0,9	0,65	5,9	8	25	0,1	1	105123	Δ	▲	▲		
R105.1805.0.1	0,1	0,5	0,9	0,65	5,9	4	25	0,1	1	105123	▲	▲		▲	▲
R105.1805.1.1	0,1	0,5	0,9	0,65	5,9	6	25	0,1	1	105123	▲	▲		▲	▲
R105.1805.2.1	0,1	0,5	0,9	0,65	5,9	8	25	0,1	1	105123	▲	▲		▲	▲
R105.1813.005.0.15	0,05	1,3	1,4	1,1	5,9	6	25	0,15	1,5	105123	▲	▲	▲		
R105.1813.005.1.15	0,05	1,3	1,4	1,1	5,9	9	25	0,15	1,5	105123	▲	▲	▲		
R105.1813.005.2.15	0,05	1,3	1,4	1,1	5,9	12	30	0,15	1,5	105123	▲	▲	▲		
R105.1813.01.0.15	0,1	1,3	1,4	1,1	5,9	6	25	0,15	1,5	105123	▲	▲	▲	▲	
R105.1813.01.1.15	0,1	1,3	1,4	1,1	5,9	9	25	0,15	1,5	105123	▲	▲	▲	▲	
R105.1813.01.2.15	0,1	1,3	1,4	1,1	5,9	12	30	0,15	1,5	105123	Δ	▲	▲	▲	
L105.1805.005.0.1	0,05	0,5	0,9	0,65	5,9	4	25	0,1	1	105123	Δ		▲		
L105.1805.005.1.1	0,05	0,5	0,9	0,65	5,9	6	25	0,1	1	105123	Δ		▲		
L105.1805.005.2.1	0,05	0,5	0,9	0,65	5,9	8	25	0,1	1	105123			▲		
L105.1805.0.1	0,1	0,5	0,9	0,65	5,9	4	25	0,1	1	105123	▲			▲	▲
L105.1805.1.1	0,1	0,5	0,9	0,65	5,9	6	25	0,1	1	105123	▲			▲	▲
L105.1805.2.1	0,1	0,5	0,9	0,65	5,9	8	25	0,1	1	105123	Δ			Δ	▲
L105.1813.005.0.15	0,05	1,3	1,4	1,1	5,9	6	25	0,15	1,5	105123	Δ		▲		
L105.1813.005.1.15	0,05	1,3	1,4	1,1	5,9	9	25	0,15	1,5	105123	Δ		▲		
L105.1813.005.2.15	0,05	1,3	1,4	1,1	5,9	12	30	0,15	1,5	105123	Δ		▲		
L105.1813.01.0.15	0,1	1,3	1,4	1,1	5,9	6	25	0,15	1,5	105123	Δ		▲	▲	
L105.1813.01.1.15	0,1	1,3	1,4	1,1	5,9	9	25	0,15	1,5	105123	Δ		▲	▲	
L105.1813.01.2.15	0,1	1,3	1,4	1,1	5,9	12	30	0,15	1,5	105123	Δ		▲	▲	
P	●	-	●	●	●										
M	●	●	●	●	●										
K	○	-	●	●	●										
N	-	-	●	●	●										
S	-	●	●	●	●										
H	-	-	-	-	-										

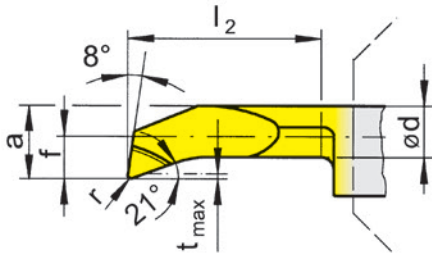
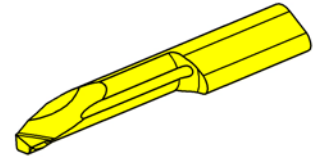
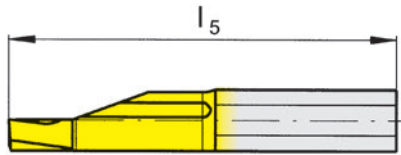
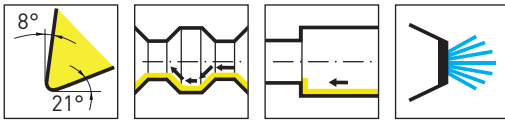

R = version à droite représentée  
R = versione destra come in figura

L = version à gauche  
L = versione sinistra a specchio

▲ en stock  
a stock

Nuance  
Leghe  
Δ 4 semaines  
4 settimane

Numéro de commande Codice prodotto	r	f	a	d	b	l <sub>2</sub>	l <sub>5</sub>	t <sub>max</sub>	D <sub>min</sub>	HIS					
											EG35	IG35	TH35	TI25	TN35
R105.1809.005.0.2	0,05	1	1,9	1,6	5,9	6	25	0,15	2	105123	▲	▲	▲	Δ	Δ
R105.1809.005.1.2	0,05	1	1,9	1,6	5,9	9	25	0,15	2	105123	▲	▲	▲	Δ	Δ
R105.1809.005.2.2	0,05	1	1,9	1,6	5,9	12	30	0,15	2	105123	▲	▲	▲	Δ	Δ
R105.1809.01.0.2	0,1	1	1,9	1,6	5,9	6	25	0,15	2	105123	Δ	▲	▲	▲	
R105.1809.01.1.2	0,1	1	1,9	1,6	5,9	9	25	0,15	2	105123	▲	▲	▲	▲	
R105.1809.01.2.2	0,1	1	1,9	1,6	5,9	12	30	0,15	2	105123	Δ	▲	▲	▲	
R105.1809.0.2	0,15	1	1,9	1,6	5,9	6	25	0,15	2	105123	▲	▲	▲	▲	▲
R105.1809.1.2	0,15	1	1,9	1,6	5,9	9	25	0,15	2	105123	▲	▲	▲	▲	▲
R105.1809.2.2	0,15	1	1,9	1,6	5,9	12	30	0,15	2	105123	▲	▲	▲	▲	▲
R105.1813.005.0.25	0,05	1,3	2,3	1,95	5,9	6	25	0,15	2,5	105123	▲	▲	▲		
R105.1813.005.1.25	0,05	1,3	2,3	1,95	5,9	9	25	0,15	2,5	105123	▲	▲	▲		
R105.1813.005.2.25	0,05	1,3	2,3	1,95	5,9	12	30	0,15	2,5	105123	Δ	▲	▲		
R105.1813.005.3.25	0,05	1,3	2,3	1,95	5,9	16	35	0,15	2,5	105123	▲	▲	▲		
L105.1809.005.0.2	0,05	1	1,9	1,6	5,9	6	25	0,15	2	105123	Δ		▲		
L105.1809.005.1.2	0,05	1	1,9	1,6	5,9	9	25	0,15	2	105123	Δ		▲		
L105.1809.005.2.2	0,05	1	1,9	1,6	5,9	12	30	0,15	2	105123	Δ		▲		
L105.1809.01.0.2	0,1	1	1,9	1,6	5,9	6	25	0,15	2	105123	Δ		▲	▲	
L105.1809.01.1.2	0,1	1	1,9	1,6	5,9	9	25	0,15	2	105123	Δ		▲	Δ	
L105.1809.01.2.2	0,1	1	1,9	1,6	5,9	12	30	0,15	2	105123	Δ		▲	▲	
L105.1809.0.2	0,15	1	1,9	1,6	5,9	6	25	0,15	2	105123	▲		▲	▲	▲
L105.1809.1.2	0,15	1	1,9	1,6	5,9	9	25	0,15	2	105123	▲		▲	▲	▲
L105.1809.2.2	0,15	1	1,9	1,6	5,9	12	30	0,15	2	105123	▲		▲	▲	▲
L105.1813.005.0.25	0,05	1,3	2,3	1,95	5,9	6	25	0,15	2,5	105123	Δ		▲		
L105.1813.005.1.25	0,05	1,3	2,3	1,95	5,9	9	25	0,15	2,5	105123	Δ		▲		
L105.1813.005.2.25	0,05	1,3	2,3	1,95	5,9	12	30	0,15	2,5	105123	Δ		▲		
L105.1813.005.3.25	0,05	1,3	2,3	1,95	5,9	16	35	0,15	2,5	105123	Δ		▲		
P	●	-	●	●	●										
M	●	●	●	●	●										
K	○	-	●	●	●										
N	-	-	●	●	●										
S	-	●	●	●	●										
H	-	-	-	-	-										

# Plaquette de coupe

## Inserto

# 105

$\varnothing \geq 3 \text{ mm}$



# A

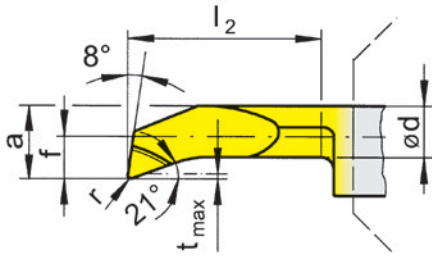
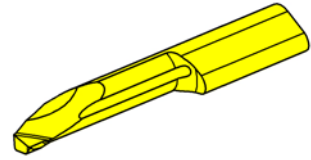
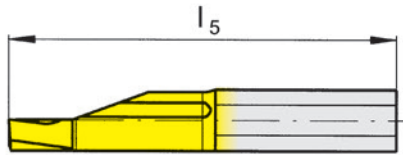
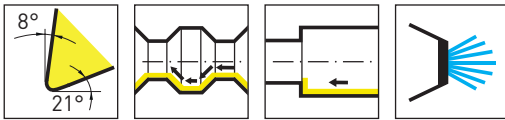

R = version à droite représentée  
R = versione destra come in figura

L = version à gauche  
L = versione sinistra a specchio

▲ en stock  
a stock

Nuance  
Leghe  
Δ 4 semaines  
4 settimane

Numéro de commande Codice prodotto	r	f	a	d	b	l <sub>2</sub>	l <sub>5</sub>	t <sub>max</sub>	D <sub>min</sub>	HIS	Nuance / Leghe				
											EG35	IG35	TH35	TI25	TN35
R105.1813.005.1.3	0,05	1,3	2,6	2,3	5,9	10	25	0,15	3	105123	▲	▲	▲	Δ	Δ
R105.1813.005.2.3	0,05	1,3	2,6	2,3	5,9	15	30	0,15	3	105123	Δ	▲	▲	▲	Δ
R105.1813.005.3.3	0,05	1,3	2,6	2,3	5,9	20	35	0,15	3	105123	▲	▲	▲	Δ	
R105.1813.01.1.3	0,1	1,3	2,6	2,3	5,9	10	25	0,15	3	105123	▲	▲	▲	▲	
R105.1813.01.2.3	0,1	1,3	2,6	2,3	5,9	15	30	0,15	3	105123	▲	▲	▲	▲	
R105.1813.01.3.3	0,1	1,3	2,6	2,3	5,9	20	35	0,15	3	105123	▲	▲	▲	▲	
R105.1813.1.3	0,2	1,3	2,6	2,3	5,9	10	25	0,15	3	105123	▲	▲	▲	▲	▲
R105.1813.2.3	0,2	1,3	2,6	2,3	5,9	15	30	0,15	3	105123	▲	▲	▲	▲	▲
R105.1813.3.3	0,2	1,3	2,6	2,3	5,9	20	35	0,15	3	105123	▲	▲	▲	▲	▲
L105.1813.005.1.3	0,05	1,3	2,6	2,3	5,9	10	25	0,15	3	105123	Δ		▲		
L105.1813.005.2.3	0,05	1,3	2,6	2,3	5,9	15	30	0,15	3	105123	Δ		▲		
L105.1813.005.3.3	0,05	1,3	2,6	2,3	5,9	20	35	0,15	3	105123	Δ		▲		
L105.1813.01.1.3	0,1	1,3	2,6	2,3	5,9	10	25	0,15	3	105123	Δ		▲	▲	
L105.1813.01.2.3	0,1	1,3	2,6	2,3	5,9	15	30	0,15	3	105123	Δ		▲	▲	
L105.1813.01.3.3	0,1	1,3	2,6	2,3	5,9	20	35	0,15	3	105123	Δ		▲	▲	
L105.1813.1.3	0,2	1,3	2,6	2,3	5,9	10	25	0,15	3	105123	▲		▲	▲	▲
L105.1813.2.3	0,2	1,3	2,6	2,3	5,9	15	30	0,15	3	105123	▲		▲	▲	▲
L105.1813.3.3	0,2	1,3	2,6	2,3	5,9	20	35	0,15	3	105123	▲		▲	▲	▲
P											●	-	●	●	●
M											●	●	●	●	●
K											○	-	●	●	●
N											-	-	●	●	●
S											-	●	●	●	●
H											-	-	-	-	-

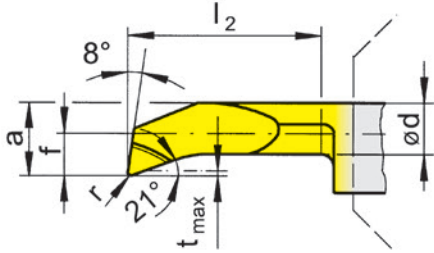
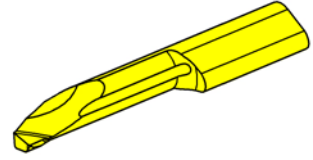
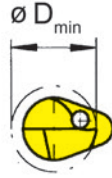
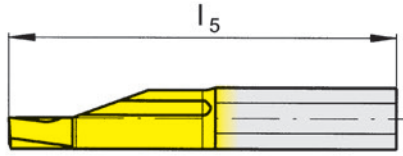
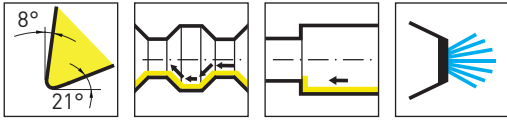

R = version à droite représentée  
R = versione destra come in figura

L = version à gauche  
L = versione sinistra a specchio

▲ en stock  
a stock

△ 4 semaines  
4 settimane

Nuance  
Leghe

Numéro de commande Codice prodotto	r	f	a	d	b	l <sub>2</sub>	l <sub>5</sub>	t <sub>max</sub>	D <sub>min</sub>	HIS	Nuance / Leghe				
											EG35	IG35	TH35	TI25	TN35
R105.1819.005.1.4	0,05	1,9	3,7	2,9	6,4	10	25	0,3	4	105124	▲	▲	▲	△	
R105.1819.005.2.4	0,05	1,9	3,7	2,9	6,4	15	30	0,3	4	105124	▲	▲	▲		
R105.1819.005.3.4	0,05	1,9	3,7	2,9	6,4	20	35	0,3	4	105124	▲	▲	▲		
R105.1819.1.4	0,2	1,9	3,7	2,9	6,4	10	25	0,3	4	105124	▲	▲	▲	▲	▲
R105.1819.2.4	0,2	1,9	3,7	2,9	6,4	15	30	0,3	4	105124	▲	▲	▲	▲	▲
R105.1819.3.4	0,2	1,9	3,7	2,9	6,4	20	35	0,3	4	105124	▲	▲	▲	▲	▲
L105.1819.005.1.4	0,05	1,9	3,7	2,9	6,4	10	25	0,3	4	105124	△		▲		
L105.1819.005.2.4	0,05	1,9	3,7	2,9	6,4	15	30	0,3	4	105124	△		▲		
L105.1819.005.3.4	0,05	1,9	3,7	2,9	6,4	20	35	0,3	4	105124	△		▲		
L105.1819.1.4	0,2	1,9	3,7	2,9	6,4	10	25	0,3	4	105124	▲		▲	▲	▲
L105.1819.2.4	0,2	1,9	3,7	2,9	6,4	15	30	0,3	4	105124	▲		▲	▲	▲
L105.1819.3.4	0,2	1,9	3,7	2,9	6,4	20	35	0,3	4	105124	▲		▲	▲	▲
P											●	-	●	●	●
M											●	●	●	●	●
K											○	-	●	●	●
N											-	-	●	●	●
S											-	●	●	●	●
H											-	-	-	-	-

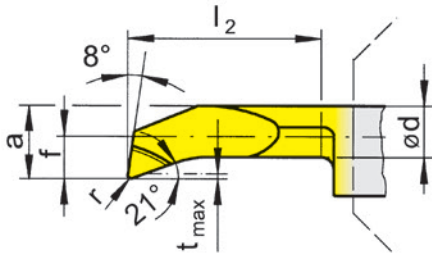
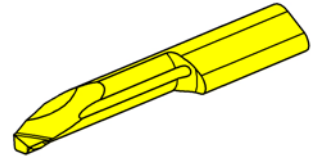
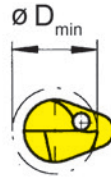
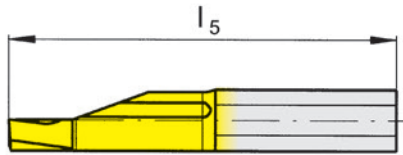
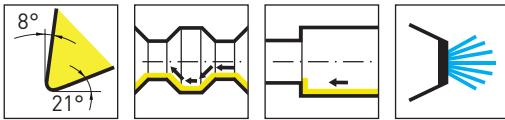

R = version à droite représentée  
R = versione destra come in figura

L = version à gauche  
L = versione sinistra a specchio

Nuance  
Leghe  
▲ en stock  
a stock  
Δ 4 semaines  
4 settimane

Numéro de commande Codice prodotto	r	f	a	d	b	l <sub>2</sub>	l <sub>5</sub>	t <sub>max</sub>	D <sub>min</sub>	HIS					
											EG35	IG35	TH35	TI25	TN35
R105.1823.005.1.5	0,05	2,3	4,7	4	7	10	25	0,5	5	105125	▲	▲	▲		
R105.1823.005.2.5	0,05	2,3	4,7	4	7	15	30	0,5	5	105125	▲	▲	▲		Δ
R105.1823.005.3.5	0,05	2,3	4,7	4	7	20	35	0,5	5	105125	▲	▲	▲		Δ
R105.1823.005.4.5	0,05	2,3	4,7	4	7	25	40	0,5	5	105125	▲	▲	▲		Δ
R105.1823.005.5.5	0,05	2,3	4,7	4	7	30	45	0,5	5	105125	Δ	▲	▲		
R105.1823.1.5	0,2	2,3	4,7	4	7	10	25	0,5	5	105125	▲	▲	▲	▲	▲
R105.1823.2.5	0,2	2,3	4,7	4	7	15	30	0,5	5	105125	▲	▲	▲	▲	▲
R105.1823.3.5	0,2	2,3	4,7	4	7	20	35	0,5	5	105125	▲	▲	▲	▲	▲
R105.1823.4.5	0,2	2,3	4,7	4	7	25	40	0,5	5	105125	▲	▲	▲	▲	▲
R105.1823.5.5	0,2	2,3	4,7	4	7	30	45	0,5	5	105125	▲	▲	▲	▲	▲
R105.1823.6.5	0,2	2,3	4,7	4	7	35	50	0,5	5	105125	▲	▲	▲	Δ	
L105.1823.005.1.5	0,05	2,3	4,7	4	7	10	25	0,5	5	105125		Δ		▲	
L105.1823.005.2.5	0,05	2,3	4,7	4	7	15	30	0,5	5	105125		Δ		▲	
L105.1823.005.3.5	0,05	2,3	4,7	4	7	20	35	0,5	5	105125		Δ		▲	
L105.1823.005.4.5	0,05	2,3	4,7	4	7	25	40	0,5	5	105125		▲		▲	
L105.1823.005.5.5	0,05	2,3	4,7	4	7	30	45	0,5	5	105125		Δ		▲	
L105.1823.1.5	0,2	2,3	4,7	4	7	10	25	0,5	5	105125	▲	▲	▲	▲	▲
L105.1823.2.5	0,2	2,3	4,7	4	7	15	30	0,5	5	105125	▲	▲	▲	▲	▲
L105.1823.3.5	0,2	2,3	4,7	4	7	20	35	0,5	5	105125	▲	▲	▲	▲	▲
L105.1823.4.5	0,2	2,3	4,7	4	7	25	40	0,5	5	105125	▲	▲	▲	▲	▲
L105.1823.5.5	0,2	2,3	4,7	4	7	30	45	0,5	5	105125	▲	▲	▲	▲	▲
											P	●	-	●	●
											M	●	●	●	●
											K	○	-	●	●
											N	-	-	●	●
											S	-	●	●	●
											H	-	-	-	-

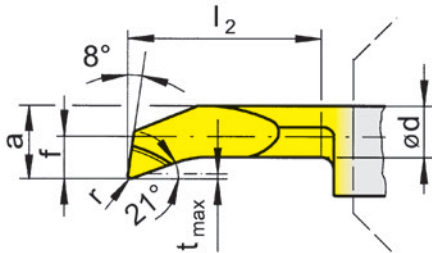
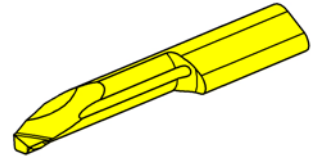
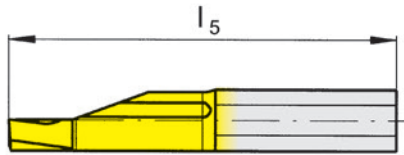
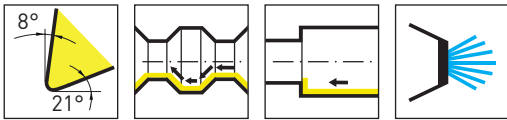

R = version à droite représentée  
R = versione destra come in figura

L = version à gauche  
L = versione sinistra a specchio

▲ en stock  
a stock

Nuance  
Leghe  
Δ 4 semaines  
4 settimane

Numéro de commande Codice prodotto	r	f	a	d	b	l <sub>2</sub>	l <sub>5</sub>	t <sub>max</sub>	D <sub>min</sub>	HIS	Nuance Leghe				
											EG35	IG35	TH35	TI25	TN35
R105.1833.005.2.6	0,05	3,3	5,7	4,7	7	15	30	0,5	6	105125	▲	▲	▲		
R105.1833.005.3.6	0,05	3,3	5,7	4,7	7	20	35	0,5	6	105125	Δ	▲	▲		
R105.1833.005.4.6	0,05	3,3	5,7	4,7	7	25	40	0,5	6	105125	Δ	▲	▲		
R105.1833.005.5.6	0,05	3,3	5,7	4,7	7	30	45	0,5	6	105125	Δ	▲			Δ
R105.1833.2.6	0,2	3,3	5,7	4,7	7	15	30	0,5	6	105125	▲	▲	▲	▲	▲
R105.1833.3.6	0,2	3,3	5,7	4,7	7	20	35	0,5	6	105125	▲	▲	▲	▲	▲
R105.1833.4.6	0,2	3,3	5,7	4,7	7	25	40	0,5	6	105125	▲	▲	▲	▲	▲
R105.1833.5.6	0,2	3,3	5,7	4,7	7	30	45	0,5	6	105125	▲	▲	▲	▲	▲
R105.1840.005.3.7	0,05	4	6,4	5,2	7	20	35	0,5	6,8	105125	Δ	▲	▲		
R105.1840.005.4.7	0,05	4	6,4	5,2	7	25	40	0,5	6,8	105125	Δ	▲	▲		
R105.1840.005.5.7	0,05	4	6,4	5,2	7	30	45	0,5	6,8	105125	Δ	▲	▲		
R105.1840.3.7	0,2	4	6,4	5,2	7	20	35	0,5	6,8	105125	▲	▲	▲	▲	▲
R105.1840.4.7	0,2	4	6,4	5,2	7	25	40	0,5	6,8	105125	▲	▲	▲	▲	▲
R105.1840.5.7	0,2	4	6,4	5,2	7	30	45	0,5	6,8	105125	▲	▲	▲	▲	▲
L105.1833.005.2.6	0,05	3,3	5,7	4,7	7	15	30	0,5	6	105125	Δ		▲		
L105.1833.005.3.6	0,05	3,3	5,7	4,7	7	20	35	0,5	6	105125	Δ		▲		
L105.1833.005.4.6	0,05	3,3	5,7	4,7	7	25	40	0,5	6	105125	Δ				
L105.1833.005.5.6	0,05	3,3	5,7	4,7	7	30	45	0,5	6	105125	Δ		Δ		
L105.1833.2.6	0,2	3,3	5,7	4,7	7	15	30	0,5	6	105125	▲		▲	▲	▲
L105.1833.3.6	0,2	3,3	5,7	4,7	7	20	35	0,5	6	105125	▲		▲	▲	▲
L105.1833.4.6	0,2	3,3	5,7	4,7	7	25	40	0,5	6	105125	▲		▲	▲	▲
L105.1833.5.6	0,2	3,3	5,7	4,7	7	30	45	0,5	6	105125	▲		▲	▲	▲
L105.1840.005.3.7	0,05	4	6,4	5,2	7	20	35	0,5	6,8	105125	Δ		▲		
L105.1840.005.4.7	0,05	4	6,4	5,2	7	25	40	0,5	6,8	105125	Δ		▲		
L105.1840.005.5.7	0,05	4	6,4	5,2	7	30	45	0,5	6,8	105125	Δ		▲		
L105.1840.3.7	0,2	4	6,4	5,2	7	20	35	0,5	6,8	105125	▲		▲	▲	▲
L105.1840.4.7	0,2	4	6,4	5,2	7	25	40	0,5	6,8	105125	▲		▲	▲	▲
L105.1840.5.7	0,2	4	6,4	5,2	7	30	45	0,5	6,8	105125	▲		▲	▲	▲
P											●	-	●	●	●
M											●	●	●	●	●
K											○	-	●	●	●
N											-	-	●	●	●
S											-	●	●	●	●
H											-	-	-	-	-

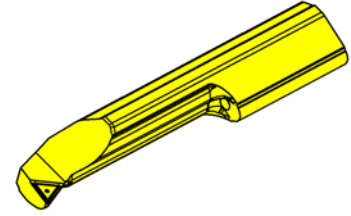
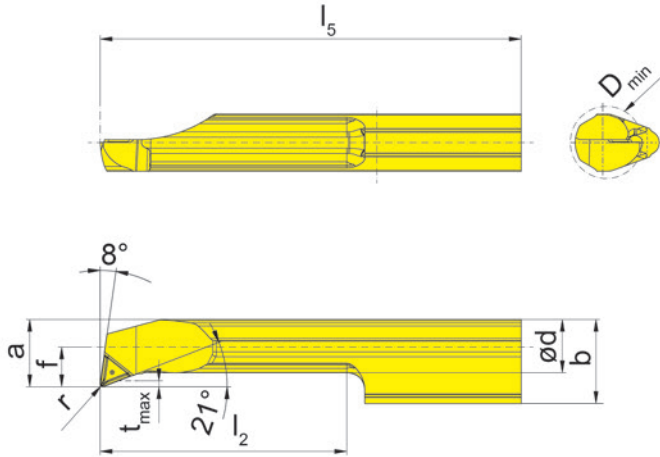
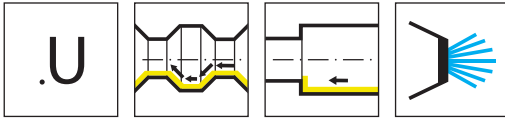

R = version à droite représentée  
R = versione destra come in figura

Nuance  
Leghe  
▲ en stock  
a stock  
Δ 4 semaines  
4 settimane

Numéro de commande Codice prodotto	r	f	a	d	b	l <sub>2</sub>	l <sub>5</sub>	t <sub>max</sub>	D <sub>min</sub>	HIS	Nuance	
											IG35	TH35
RS105.1833.2.4.U20	0,2	3,3	3,7	2,5	7	15	30	0,5	4	105125	▲	▲
RS105.1833.3.4.U20	0,2	3,3	3,7	2,5	7	20	35	0,5	4	105125	▲	▲
RS105.1833.2.5.U20	0,2	3,3	4,7	3,5	7	15	30	0,5	5	105125	▲	▲
RS105.1833.3.5.U20	0,2	3,3	4,7	3,5	7	20	35	0,5	5	105125	▲	▲
RS105.1833.4.5.U20	0,2	3,3	4,7	3,5	7	25	40	0,5	5	105125	▲	▲
RS105.1833.2.6.U20	0,2	3,3	5,6	4,4	7	15	30	0,5	6	105125	▲	▲
RS105.1833.3.6.U20	0,2	3,3	5,6	4,4	7	20	35	0,5	6	105125	▲	▲
RS105.1833.4.6.U20	0,2	3,3	5,6	4,4	7	25	40	0,5	6	105125	▲	▲
											P	- ●
											M	● ●
											K	- ●
											N	- ●
											S	● ●
											H	- -

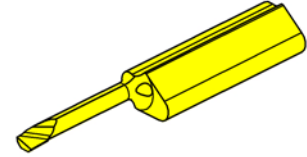
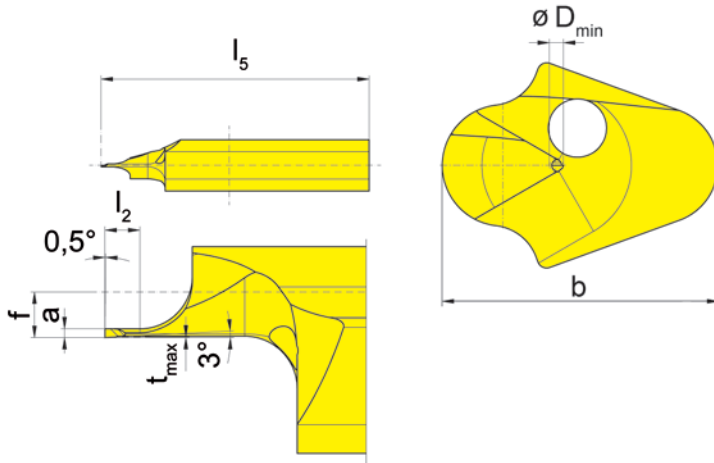
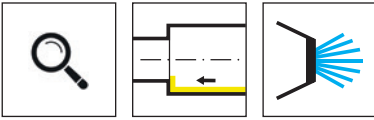

R = version à droite représentée  
R = versione destra come in figura

Nuance  
Leghe  
▲ en stock  
a stock  
Δ 4 semaines  
4 settimane

Numéro de commande Codice prodotto	f	a	b	l <sub>2</sub>	l <sub>5</sub>	t <sub>max</sub>	D <sub>min</sub>	HIS	ES15
R105.9013.000.0.02	1,3	0,17	5,9	1	23	0,015	0,2	105123	Δ
R105.9013.000.0.03	1,3	0,25	5,9	1	23	0,015	0,3	105123	▲
R105.9013.000.0.05	1,3	0,4	5,9	2	23	0,02	0,5	105123	▲
R105.9013.000.0.07	1,3	0,6	5,9	2	23	0,02	0,7	105123	▲
									P ●
									M ●
									K ○
									N -
									S -
									H -

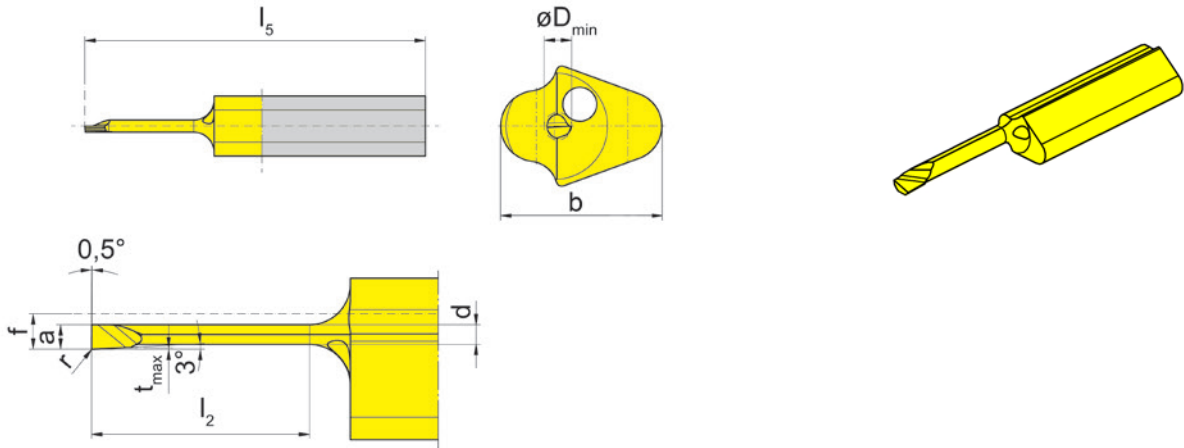
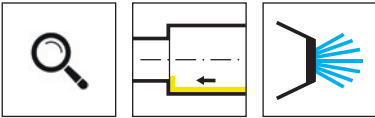

R = version à droite représentée  
R = versione destra come in figura

Nuance  
Leghe  
▲ en stock    Δ 4 semaines  
a stock        4 settimane

Numéro de commande Codice prodotto	r	f	a	d	b	$l_2$	$l_5$	$t_{max}$	$D_{min}$	HIS	ES15
R105.9013.000.0.1	-	1,3	0,9	0,72	5,9	4	25	0,05	1	105123	▲
R105.9013.000.2.1	-	1,3	0,9	0,72	5,9	8	25	0,05	1	105123	Δ
R105.9013.003.0.1	0,03	1,3	0,9	0,72	5,9	4	25	0,05	1	105123	▲
R105.9013.003.2.1	0,03	1,3	0,9	0,72	5,9	8	25	0,05	1	105123	Δ
R105.9013.000.0.15	-	1,3	1,4	1,15	5,9	6	25	0,1	1,5	105123	▲
R105.9013.000.1.15	-	1,3	1,4	1,15	5,9	9	25	0,1	1,5	105123	▲
R105.9013.003.0.15	0,03	1,3	1,4	1,15	5,9	6	25	0,1	1,5	105123	▲
R105.9013.003.1.15	0,03	1,3	1,4	1,15	5,9	9	25	0,1	1,5	105123	▲
											P ●
											M ●
											K ○
											N -
											S -
											H -

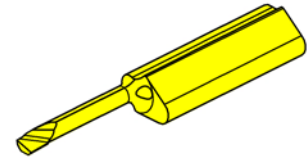
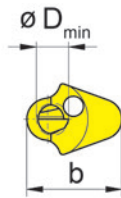
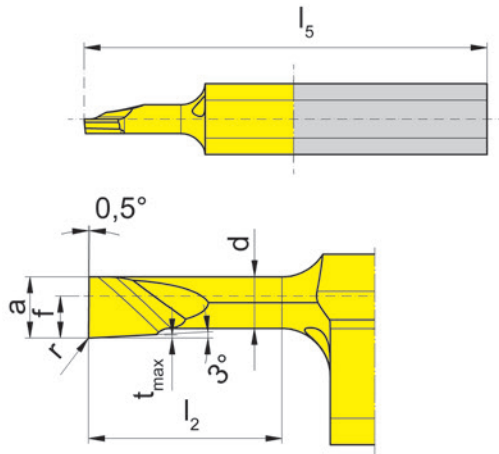
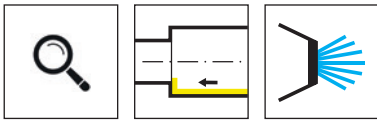

R = version à droite représentée

R = versione destra come in figura

Nuance

Leghe

▲ en stock

a stock

Δ 4 semaines

4 settimane

Numéro de commande Codice prodotto	r	f	a	d	b	$l_2$	$l_5$	$t_{max}$	$D_{min}$	HIS	ES15
R105.9013.000.0.2	-	1,3	1,9	1,6	5,9	6	25	0,1	2	105123	▲
R105.9013.000.2.2	-	1,3	1,9	1,6	5,9	12	30	0,1	2	105123	Δ
R105.9013.003.0.2	0,03	1,3	1,9	1,6	5,9	6	25	0,1	2	105123	▲
R105.9013.003.2.2	0,03	1,3	1,9	1,6	5,9	12	30	0,1	2	105123	▲
R105.9013.000.0.25	-	1,3	2,3	2	5,9	6	25	0,1	2,5	105123	Δ
R105.9013.000.2.25	-	1,3	2,3	2	5,9	12	30	0,1	2,5	105123	Δ
R105.9013.000.3.25	-	1,3	2,3	2	5,9	16	35	0,1	2,5	105123	Δ
R105.9013.003.0.25	0,03	1,3	2,3	2	5,9	6	25	0,1	2,5	105123	▲
R105.9013.003.2.25	0,03	1,3	2,3	2	5,9	12	30	0,1	2,5	105123	▲
R105.9013.003.3.25	0,03	1,3	2,3	2	5,9	16	35	0,1	2,5	105123	▲
											P ●
											M ●
											K ○
											N -
											S -
											H -

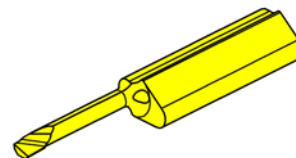
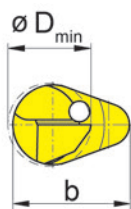
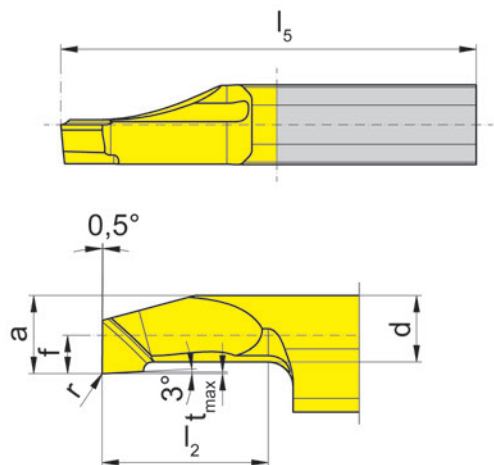
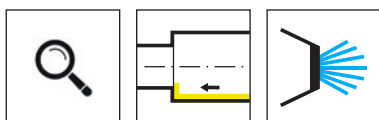

Nuance  
Leghe

R = version à droite représentée

R = versione destra come in figura

▲ en stock  
a stock

Δ 4 semaines  
4 settimane

Número de commande Codice prodotto	r	f	a	d	b	$l_2$	$l_5$	$t_{max}$	$D_{min}$	HIS	ES15
R105.9013.000.1.3	-	1,3	2,6	2,3	5,9	10	25	0,1	3	105123	▲
R105.9013.000.3.3	-	1,3	2,6	2,3	5,9	20	35	0,1	3	105123	Δ
R105.9013.003.1.3	0,03	1,3	2,6	2,3	5,9	10	25	0,1	3	105123	▲
R105.9013.003.3.3	0,03	1,3	2,6	2,3	5,9	20	35	0,1	3	105123	▲
R105.9019.000.1.4	-	1,9	3,7	3,2	6,4	10	25	0,1	4	105124	Δ
R105.9019.000.3.4	-	1,9	3,7	3,2	6,4	20	35	0,1	4	105124	Δ
R105.9019.003.1.4	0,03	1,9	3,7	3,2	6,4	10	25	0,1	4	105124	Δ
R105.9019.003.3.4	0,03	1,9	3,7	3,2	6,4	20	35	0,1	4	105124	▲
											P ●
											M ●
											K ○
											N -
											S -
											H -

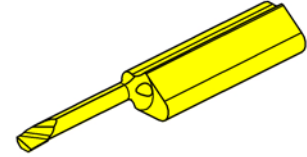
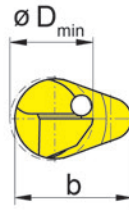
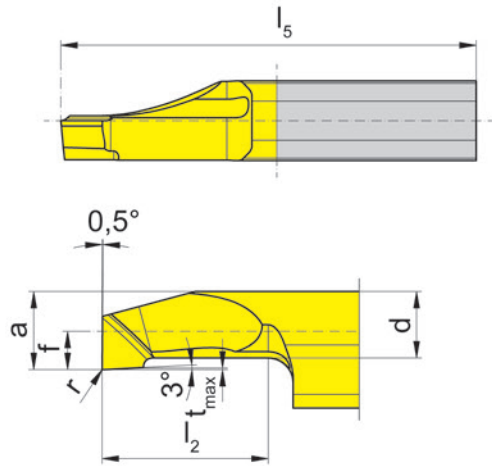
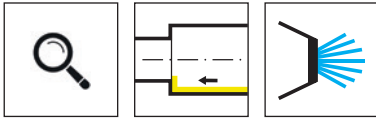

R = version à droite représentée  
R = versione destra come in figura

Nuance  
Leghe  
▲ en stock  
a stock  
△ 4 semaines  
4 settimane

Numéro de commande Codice prodotto	r	f	a	d	b	$l_2$	$l_5$	$t_{max}$	$D_{min}$	HIS	ES15
R105.9023.000.1.5	-	2,3	4,7	4	7	10	25	0,1	5	105125	▲
R105.9023.000.3.5	-	2,3	4,7	4	7	20	35	0,1	5	105125	△
R105.9023.000.5.5	-	2,3	4,7	4	7	30	45	0,1	5	105125	▲
R105.9023.003.1.5	0,03	2,3	4,7	4	7	10	25	0,1	5	105125	▲
R105.9023.003.3.5	0,03	2,3	4,7	4	7	20	35	0,1	5	105125	△
R105.9023.003.5.5	0,03	2,3	4,7	4	7	30	45	0,1	5	105125	▲
	P	●									
	M	●									
	K	○									
	N	-									
	S	-									
	H	-									

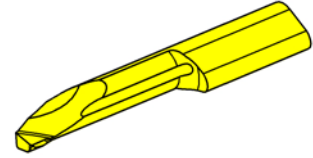
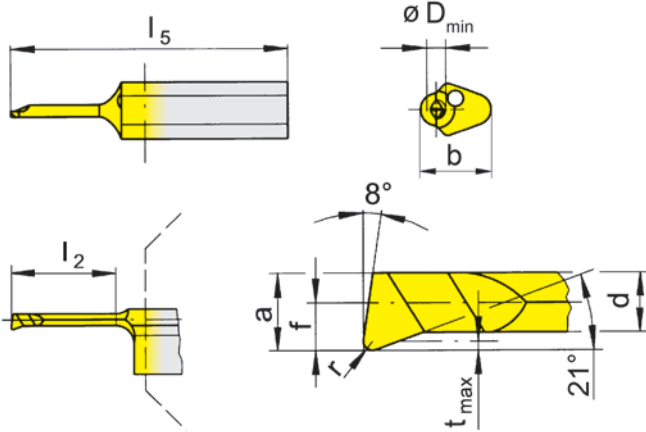
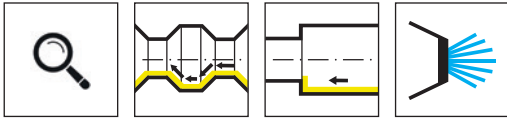

R = version à droite représentée  
R = versione destra come in figura

L = version à gauche  
L = versione sinistra a specchio

Nuance  
Leghe  
▲ en stock     Δ 4 semaines  
a stock             4 settimane

Numéro de commande Codice prodotto	r	f	a	d	b	$l_2$	$l_5$	$t_{max}$	$D_{min}$	HIS	ES15
R105.2108.003.0.1	0,03	0,5	0,9	0,65	5,9	4	25	0,1	1	105123	▲
R105.2108.003.1.1	0,03	0,5	0,9	0,65	5,9	6	25	0,1	1	105123	▲
R105.2108.003.2.1	0,03	0,5	0,9	0,65	5,9	8	25	0,1	1	105123	▲
R105.2108.008.0.1	0,08	0,5	0,9	0,65	5,9	4	25	0,1	1	105123	▲
R105.2108.008.1.1	0,08	0,5	0,9	0,65	5,9	6	25	0,1	1	105123	▲
R105.2108.008.2.1	0,08	0,5	0,9	0,65	5,9	8	25	0,1	1	105123	▲
R105.2108.003.0.15	0,03	1,3	1,4	1,1	5,9	6	25	0,15	1,5	105123	▲
R105.2108.003.1.15	0,03	1,3	1,4	1,1	5,9	9	25	0,15	1,5	105123	▲
R105.2108.003.2.15	0,03	1,3	1,4	1,1	5,9	12	25	0,15	1,5	105123	▲
R105.2108.008.0.15	0,08	1,3	1,4	1,1	5,9	6	25	0,15	1,5	105123	▲
R105.2108.008.1.15	0,08	1,3	1,4	1,1	5,9	9	25	0,15	1,5	105123	▲
R105.2108.008.2.15	0,08	1,3	1,4	1,1	5,9	12	30	0,15	1,5	105123	▲
											P ●
											M ●
											K ○
											N -
											S -
											H -

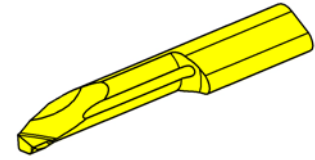
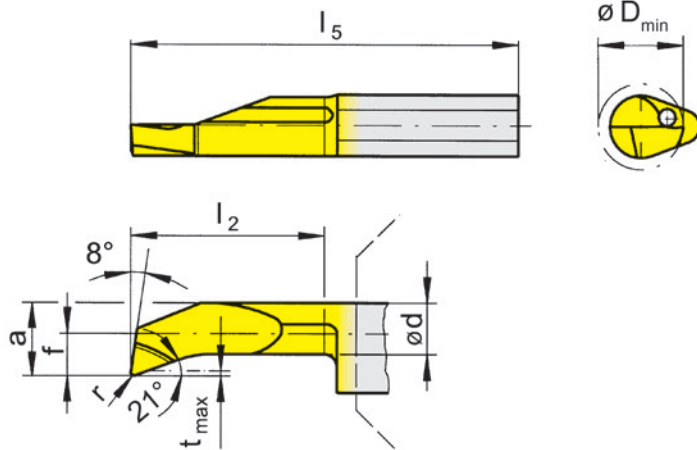
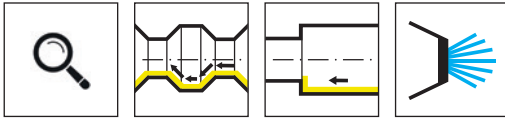

R = version à droite représentée  
R = versione destra come in figura

L = version à gauche  
L = versione sinistra a specchio

▲ en stock  
a stock

Nuance  
Leghe  
Δ 4 semaines  
4 settimane

Numéro de commande Codice prodotto	r	f	a	d	b	$l_2$	$l_5$	$t_{max}$	$D_{min}$	HIS	ES15
R105.2108.003.0.2	0,03	1	1,9	1,6	5,9	6	25	0,15	2	105123	▲
R105.2108.003.1.2	0,03	1	1,9	1,6	5,9	9	25	0,15	2	105123	▲
R105.2108.003.2.2	0,03	1	1,9	1,6	5,9	12	30	0,15	2	105123	▲
R105.2108.008.0.2	0,08	1	1,9	1,6	5,9	6	25	0,15	2	105123	▲
R105.2108.008.1.2	0,08	1	1,9	1,6	5,9	9	25	0,15	2	105123	▲
R105.2108.008.2.2	0,08	1	1,9	1,6	5,9	12	30	0,15	2	105123	▲
R105.2108.003.1.3	0,03	1,3	2,6	2,3	5,9	10	25	0,15	3	105123	▲
R105.2108.003.2.3	0,03	1,3	2,6	2,3	5,9	15	30	0,15	3	105123	▲
R105.2108.003.3.3	0,03	1,3	2,6	2,3	5,9	20	35	0,15	3	105123	▲
R105.2108.008.1.3	0,08	1,3	2,6	2,3	5,9	10	25	0,15	3	105123	▲
R105.2108.008.2.3	0,08	1,3	2,6	2,3	5,9	15	30	0,15	3	105123	▲
R105.2108.008.3.3	0,08	1,3	2,6	2,3	5,9	20	35	0,15	3	105123	▲
P	●										
M	●										
K	o										
N	-										
S	-										
H	-										

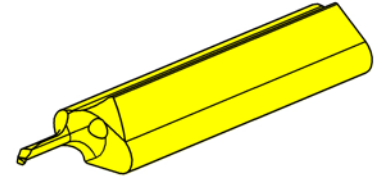
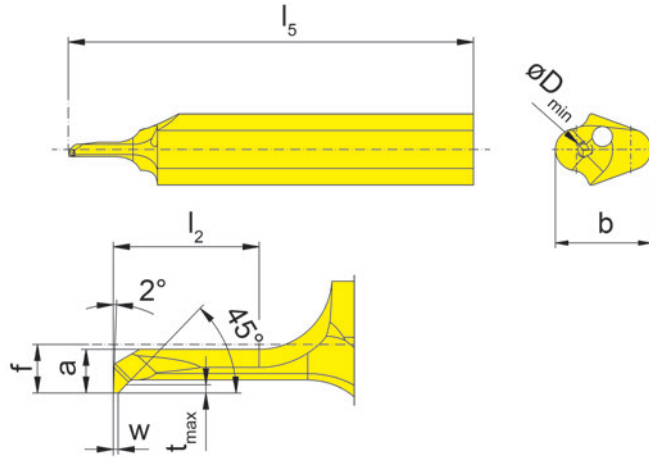
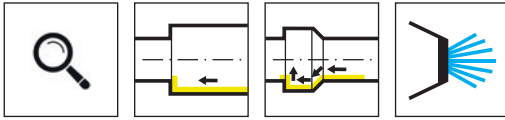

R = version à droite représentée  
R = versione destra come in figura

L = version à gauche  
L = versione sinistra a specchio

Nuance  
Leghe  
▲ en stock  
a stock  
△ 4 semaines  
4 settimane

Numéro de commande Codice prodotto	w	f	a	b	l <sub>2</sub>	l <sub>5</sub>	t <sub>max</sub>	D <sub>min</sub>	HIS	ES15
R105.4502.003.0.03	0,03	1	0,25	5,9	0,6	25	0,05	0,3	105123	▲
R105.4502.003.0.04	0,03	1	0,33	5,9	0,8	25	0,07	0,4	105123	▲
R105.4502.003.0.05	0,03	1	0,45	5,9	1,2	25	0,08	0,5	105123	▲
R105.4502.003.0.06	0,03	1	0,52	5,9	1,2	25	0,1	0,6	105123	▲
R105.4502.003.0.07	0,03	1	0,6	5,9	1,2	25	0,12	0,7	105123	▲
R105.4502.005.0.08	0,05	1	0,7	5,9	1,8	25	0,15	0,8	105123	▲
R105.4502.005.0.09	0,05	1	0,8	5,9	1,8	25	0,15	0,9	105123	▲
R105.4502.010.0.10	0,1	1	0,9	5,9	3	25	0,17	1	105123	▲
R105.4502.010.0.12	0,1	1	1	5,9	3,6	25	0,2	1,2	105123	▲
R105.4502.010.0.15	0,1	1,3	1,4	5,9	4,5	25	0,25	1,5	105123	▲
R105.4502.020.0.20	0,2	1,3	1,8	5,9	6	25	0,35	2	105123	▲
R105.4502.020.0.25	0,2	1,3	2,3	5,9	7,5	25	0,45	2,5	105123	▲
R105.4502.030.0.30	0,3	1,3	2,6	5,9	9	25	0,5	3	105123	▲
R105.4502.030.0.35	0,3	1,9	3,2	6,4	10	25	0,6	3,5	105124	▲
										P ●
										M ●
										K ○
										N -
										S -
										H -

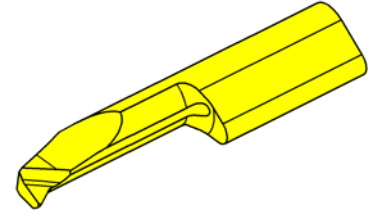
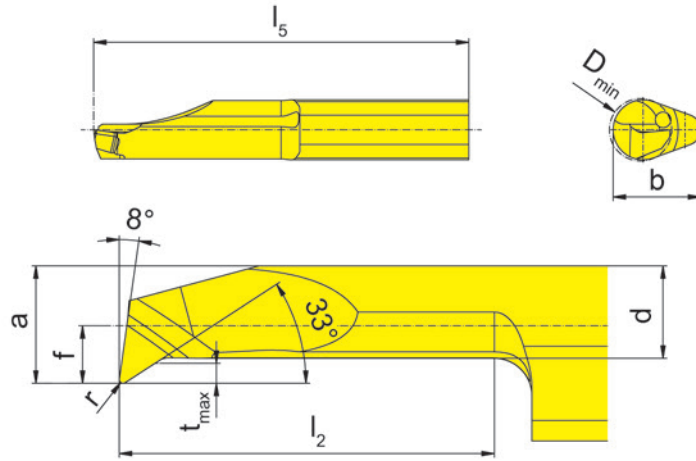
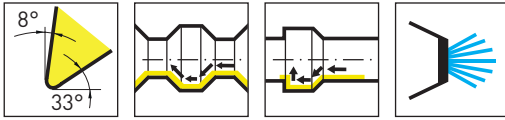

R = version à droite représentée  
R = versione destra come in figura

L = version à gauche  
L = versione sinistra a specchio

▲ en stock  
a stock

Nuance  
Leghe  
Δ 4 semaines  
4 settimane

Numéro de commande Codice prodotto	r	f	a	d	b	l <sub>2</sub>	l <sub>5</sub>	t <sub>max</sub>	D <sub>min</sub>	HIS	Nuance	
											EG35	IG35
R105.3315.005.1.2	0,05	1,5	1,9	1,45	5,9	9	25	0,3	2	105123	▲	▲
R105.3315.005.2.2	0,05	1,5	1,9	1,45	5,9	12	30	0,3	2	105123	▲	▲
R105.3313.005.1.3	0,05	1,3	2,6	2	5,9	10	25	0,4	3	105123	▲	▲
R105.3313.005.2.3	0,05	1,3	2,6	2	5,9	15	30	0,4	3	105123	▲	▲
R105.3319.1.4	0,15	1,9	3,7	2,9	6,4	10	25	0,6	4	105124	▲	▲
R105.3319.3.4	0,15	1,9	3,7	2,9	6,4	20	35	0,6	4	105124	▲	▲
R105.3323.2.5	0,15	2,3	4,7	3,7	7	15	30	0,8	5	105125	▲	▲
R105.3323.4.5	0,15	2,3	4,7	3,7	7	25	40	0,8	5	105125	▲	▲
R105.3333.3.6	0,15	3,3	5,7	3,7	7	20	35	1,8	6	105125	▲	▲
R105.3333.5.6	0,15	3,3	5,7	3,7	7	30	45	1,8	6	105125	▲	▲
L105.3319.1.4	0,15	1,9	3,7	2,9	6,4	10	25	0,6	4	105124	Δ	
L105.3319.3.4	0,15	1,9	3,7	2,9	6,4	20	35	0,6	4	105124	Δ	
L105.3323.2.5	0,15	2,3	4,7	3,7	7	15	30	0,8	5	105125	Δ	
L105.3323.4.5	0,15	2,3	4,7	3,7	7	25	40	0,8	5	105125	Δ	
L105.3333.3.6	0,15	3,3	5,7	3,7	7	20	35	1,8	6	105125	Δ	
L105.3333.5.6	0,15	3,3	5,7	3,7	7	30	45	1,8	6	105125	Δ	
P	●	-										
M	●	●										
K	o	-										
N	-	-										
S	-	●										
H	-	-										

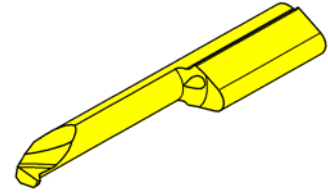
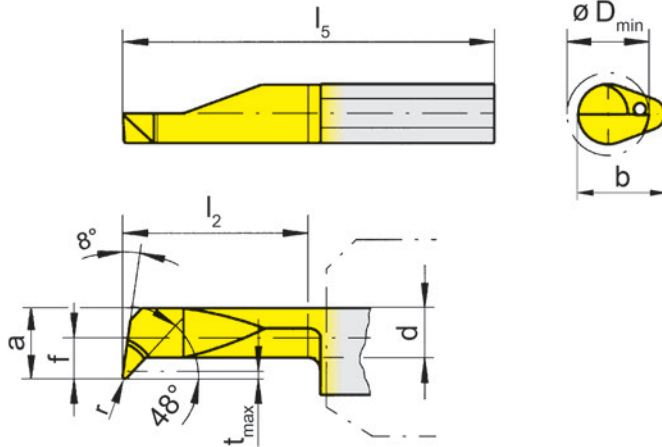
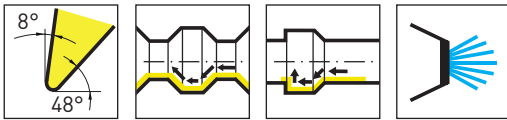

R = version à droite représentée  
R = versione destra come in figura

L = version à gauche  
L = versione sinistra a specchio

Nuance  
Leghe  
▲ en stock  
a stock  
Δ 4 semaines  
4 settimane

Numéro de commande Codice prodotto	r	f	a	d	b	l <sub>2</sub>	l <sub>5</sub>	t <sub>max</sub>	D <sub>min</sub>	HIS	Nuance					
											EG35	ES15	IG35	TH35	TI25	TN35
R105.4715.005.1.2	0,05	1,5	1,9	1,45	5,9	9	25	0,3	2	105123	▲	▲	▲			
R105.4715.005.2.2	0,05	1,5	1,9	1,45	5,9	12	30	0,3	2	105123	▲	Δ	▲			
R105.4713.005.1.3	0,05	1,3	2,6	2	5,9	10	25	0,4	3	105123	▲	▲	▲			
R105.4713.005.2.3	0,05	1,3	2,6	2	5,9	15	30	0,4	3	105123	▲	▲	▲			
R105.4719.1.4	0,15	1,9	3,7	2,9	6,4	10	25	0,6	4	105124	▲		▲	▲		
R105.4719.3.4	0,15	1,9	3,7	2,9	6,4	20	35	0,6	4	105124	▲		▲	▲	▲	▲
R105.4723.2.5	0,15	2,3	4,7	3,7	7	15	30	0,8	5	105125	▲		▲	▲	▲	Δ
R105.4723.4.5	0,15	2,3	4,7	3,7	7	25	40	0,8	5	105125	▲		▲	▲	▲	▲
R105.4733.3.6	0,15	3,3	5,7	3,7	7	20	35	1,8	6	105125	▲		▲	▲	▲	▲
R105.4733.5.6	0,15	3,3	5,7	3,7	7	30	45	1,8	6	105125	▲		▲	▲	Δ	▲
L105.4719.1.4	0,15	1,9	3,7	2,9	6,4	10	25	0,6	4	105124	▲		▲	▲		
L105.4719.3.4	0,15	1,9	3,7	2,9	6,4	20	35	0,6	4	105124	▲		▲	▲	▲	▲
L105.4723.2.5	0,15	2,3	4,7	3,7	7	15	30	0,8	5	105125	Δ		▲	▲	▲	
L105.4723.4.5	0,15	2,3	4,7	3,7	7	25	40	0,8	5	105125	▲		▲	▲	▲	▲
L105.4733.3.6	0,15	3,3	5,7	3,7	7	20	35	1,8	6	105125	▲		▲	▲	▲	▲
L105.4733.5.6	0,15	3,3	5,7	3,7	7	30	45	1,8	6	105125	▲		▲	▲	Δ	▲
P											●	●	-	●	●	●
M											●	●	●	●	●	●
K											○	○	-	●	●	●
N											-	-	-	●	●	●
S											-	-	●	●	●	●
H											-	-	-	-	-	-

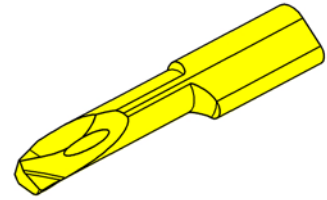
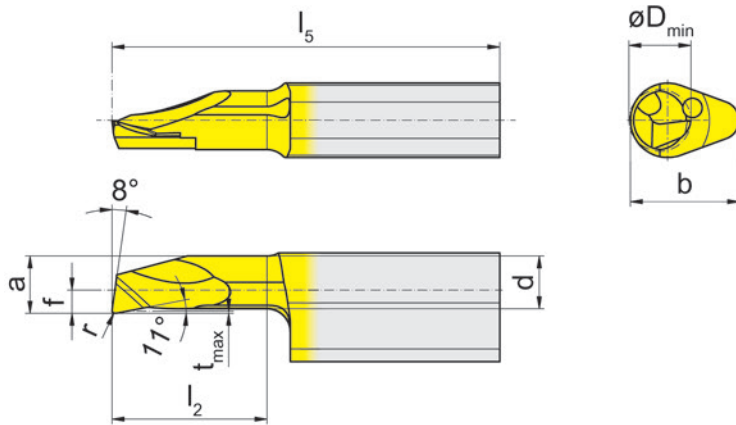
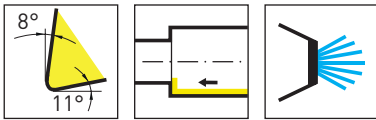

R = version à droite représentée  
R = versione destra come in figura

L = version à gauche  
L = versione sinistra a specchio

▲ en stock  
a stock

Nuance  
Leghe  
Δ 4 semaines  
4 settimane

Numéro de commande Codice prodotto	r	f	a	d	b	l <sub>2</sub>	l <sub>5</sub>	t <sub>max</sub>	D <sub>min</sub>	HIS	Nuance Leghe		
											EG35	IG35	TH35
R105.1019.005.1.4	0,05	1,5	3,7	3,4	7	10	25	0,15	4	105125	▲	▲	▲
R105.1019.005.2.4	0,05	1,5	3,7	3,4	7	15	30	0,15	4	105125	Δ	▲	▲
R105.1019.005.3.4	0,05	1,5	3,7	3,4	7	20	35	0,15	4	105125	Δ	▲	▲
R105.1019.005.4.4	0,05	1,5	3,7	3,4	7	25	40	0,15	4	105125	Δ	▲	▲
R105.1019.1.4	0,2	1,5	3,7	3,4	7	10	25	0,15	4	105125	▲	▲	▲
R105.1019.2.4	0,2	1,5	3,7	3,4	7	15	30	0,15	4	105125	▲	▲	▲
R105.1019.3.4	0,2	1,5	3,7	3,4	7	20	35	0,15	4	105125	▲	▲	▲
R105.1019.4.4	0,2	1,5	3,7	3,4	7	25	40	0,15	4	105125	▲	▲	▲
L105.1019.005.1.4	0,05	1,5	3,7	3,4	7	10	25	0,15	4	105125	▲		▲
L105.1019.005.2.4	0,05	1,5	3,7	3,4	7	15	30	0,15	4	105125	Δ		▲
L105.1019.005.3.4	0,05	1,5	3,7	3,4	7	20	35	0,15	4	105125	Δ		▲
L105.1019.005.4.4	0,05	1,5	3,7	3,4	7	25	40	0,15	4	105125	Δ		▲
L105.1019.1.4	0,2	1,5	3,7	3,4	7	10	25	0,15	4	105125	Δ		▲
L105.1019.2.4	0,2	1,5	3,7	3,4	7	15	30	0,15	4	105125	Δ		▲
L105.1019.3.4	0,2	1,5	3,7	3,4	7	20	35	0,15	4	105125	Δ		▲
L105.1019.4.4	0,2	1,5	3,7	3,4	7	25	40	0,15	4	105125	Δ		▲
Version renforcée Versione rinforzata													
P	●	-	●										
M	●	●	●										
K	○	-	●										
N	-	-	●										
S	-	●	●										
H	-	-	-										

# Plaque de coupe Inserto

# 105

$\varnothing \geq 5 \text{ mm}$



# A

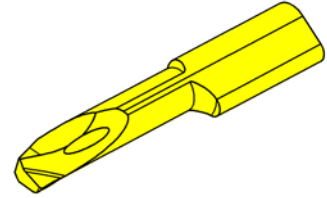
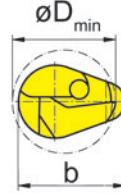
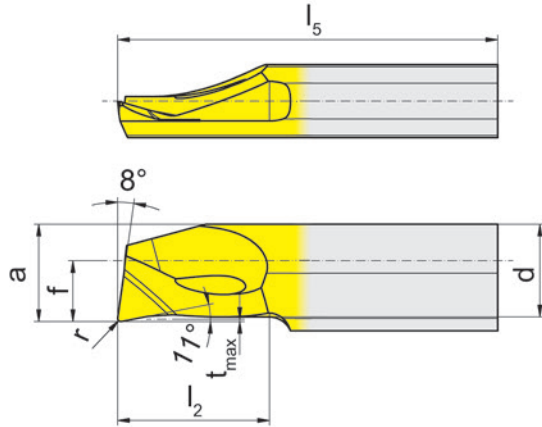
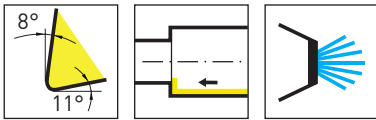

R = version à droite représentée  
R = versione destra come in figura

L = version à gauche  
L = versione sinistra a specchio

▲ en stock  
a stock

Nuance  
Leghe  
△ 4 semaines  
4 settimane

Numéro de commande Codice prodotto	r	f	a	d	b	l <sub>2</sub>	l <sub>5</sub>	t <sub>max</sub>	D <sub>min</sub>	HIS	Nuance / Leghe		
											EG35	IG35	TH35
R105.1023.005.1.5	0,05	2,8	4,7	4,4	7	10	25	0,15	5	105125	▲	▲	▲
R105.1023.005.2.5	0,05	2,8	4,7	4,4	7	15	30	0,15	5	105125	▲	▲	▲
R105.1023.005.3.5	0,05	2,8	4,7	4,4	7	20	35	0,15	5	105125	△	▲	▲
R105.1023.005.4.5	0,05	2,8	4,7	4,4	7	25	40	0,15	5	105125	△	▲	▲
R105.1023.005.5.5	0,05	2,8	4,7	4,4	7	30	45	0,15	5	105125	△	▲	▲
R105.1023.005.6.5	0,05	2,8	4,7	4,4	7	35	50	0,15	5	105125	△	▲	▲
R105.1023.1.5	0,2	2,8	4,7	4,4	7	10	25	0,15	5	105125	▲	▲	▲
R105.1023.2.5	0,2	2,8	4,7	4,4	7	15	30	0,15	5	105125	▲	▲	▲
R105.1023.3.5	0,2	2,8	4,7	4,4	7	20	35	0,15	5	105125	▲	▲	▲
R105.1023.4.5	0,2	2,8	4,7	4,4	7	25	40	0,15	5	105125	▲	▲	▲
R105.1023.5.5	0,2	2,8	4,7	4,4	7	30	45	0,15	5	105125	▲	▲	▲
R105.1023.6.5	0,2	2,8	4,7	4,4	7	35	50	0,15	5	105125	▲	▲	▲
L105.1023.005.1.5	0,05	2,8	4,7	4,4	7	10	25	0,15	5	105125	△		▲
L105.1023.005.2.5	0,05	2,8	4,7	4,4	7	15	30	0,15	5	105125	△		△
L105.1023.005.3.5	0,05	2,8	4,7	4,4	7	20	35	0,15	5	105125	△		▲
L105.1023.005.4.5	0,05	2,8	4,7	4,4	7	25	40	0,15	5	105125	△		▲
L105.1023.005.5.5	0,05	2,8	4,7	4,4	7	30	45	0,15	5	105125	△		▲
L105.1023.005.6.5	0,05	2,8	4,7	4,4	7	35	50	0,15	5	105125	△		▲
L105.1023.1.5	0,2	2,8	4,7	4,4	7	10	25	0,15	5	105125	△		▲
L105.1023.2.5	0,2	2,8	4,7	4,4	7	15	30	0,15	5	105125			▲
L105.1023.3.5	0,2	2,8	4,7	4,4	7	20	35	0,15	5	105125	△		▲
L105.1023.4.5	0,2	2,8	4,7	4,4	7	25	40	0,15	5	105125	△		▲
L105.1023.5.5	0,2	2,8	4,7	4,4	7	30	45	0,15	5	105125	△		▲
L105.1023.6.5	0,2	2,8	4,7	4,4	7	35	50	0,15	5	105125	△		▲

Version renforcée  
Versione rinforzata

P	●	-	●
M	●	●	●
K	○	-	●
N	-	-	●
S	-	●	●
H	-	-	-

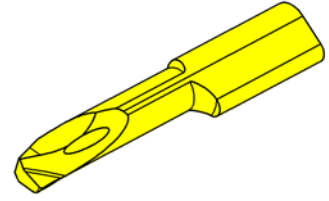
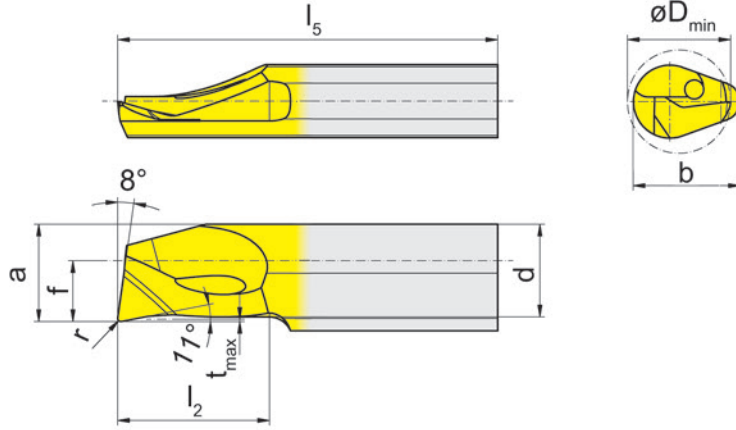
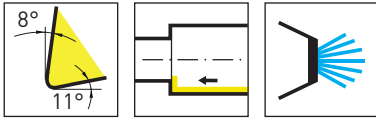

R = version à droite représentée  
R = versione destra come in figura

L = version à gauche  
L = versione sinistra a specchio

▲ en stock  
a stock

Nuance  
Leghe  
△ 4 semaines  
4 settimane

Numéro de commande Codice prodotto	r	f	a	d	b	l <sub>2</sub>	l <sub>5</sub>	t <sub>max</sub>	D <sub>min</sub>	HIS	Nuance		
											EG35	IG35	TH35
R105.1033.005.1.6	0,05	3,3	5,7	5,4	7	10	25	0,15	6	105125	▲	▲	▲
R105.1033.005.2.6	0,05	3,3	5,7	5,4	7	15	30	0,15	6	105125	△	▲	▲
R105.1033.005.3.6	0,05	3,3	5,7	5,4	7	20	35	0,15	6	105125	▲	▲	▲
R105.1033.005.4.6	0,05	3,3	5,7	5,4	7	25	40	0,15	6	105125	△	▲	▲
R105.1033.005.5.6	0,05	3,3	5,7	5,4	7	30	45	0,15	6	105125	△	▲	▲
R105.1033.005.6.6	0,05	3,3	5,7	5,4	7	35	50	0,15	6	105125	△	▲	▲
R105.1033.1.6	0,2	3,3	5,7	5,4	7	10	25	0,15	6	105125	▲	▲	▲
R105.1033.2.6	0,2	3,3	5,7	5,4	7	15	30	0,15	6	105125	▲	▲	▲
R105.1033.3.6	0,2	3,3	5,7	5,4	7	20	35	0,15	6	105125	▲	▲	▲
R105.1033.4.6	0,2	3,3	5,7	5,4	7	25	40	0,15	6	105125	▲	▲	▲
R105.1033.5.6	0,2	3,3	5,7	5,4	7	30	45	0,15	6	105125	▲	▲	▲
R105.1033.6.6	0,2	3,3	5,7	5,4	7	35	50	0,15	6	105125	▲	▲	▲
L105.1033.005.1.6	0,05	3,3	5,7	5,4	7	10	25	0,15	6	105125	△		▲
L105.1033.005.2.6	0,05	3,3	5,7	5,4	7	15	30	0,15	6	105125	△		▲
L105.1033.005.3.6	0,05	3,3	5,7	5,4	7	20	35	0,15	6	105125	△		▲
L105.1033.005.4.6	0,05	3,3	5,7	5,4	7	25	40	0,15	6	105125	△		△
L105.1033.005.5.6	0,05	3,3	5,7	5,4	7	30	45	0,15	6	105125	△		▲
L105.1033.005.6.6	0,05	3,3	5,7	5,4	7	35	50	0,15	6	105125	△		▲
L105.1033.1.6	0,2	3,3	5,7	5,4	7	10	25	0,15	6	105125			▲
L105.1033.2.6	0,2	3,3	5,7	5,4	7	15	30	0,15	6	105125	△		▲
L105.1033.3.6	0,2	3,3	5,7	5,4	7	20	35	0,15	6	105125	△		▲
L105.1033.4.6	0,2	3,3	5,7	5,4	7	25	40	0,15	6	105125	△		▲
L105.1033.5.6	0,2	3,3	5,7	5,4	7	30	45	0,15	6	105125	△		▲
L105.1033.6.6	0,2	3,3	5,7	5,4	7	35	50	0,15	6	105125	△		▲

Version renforcée  
Versione rinforzata

P	●	-	●
M	●	●	●
K	○	-	●
N	-	-	●
S	-	●	●
H	-	-	-

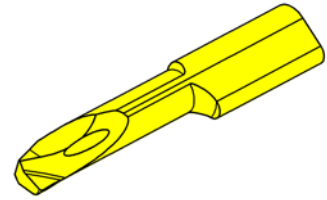
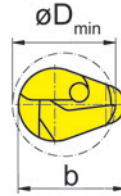
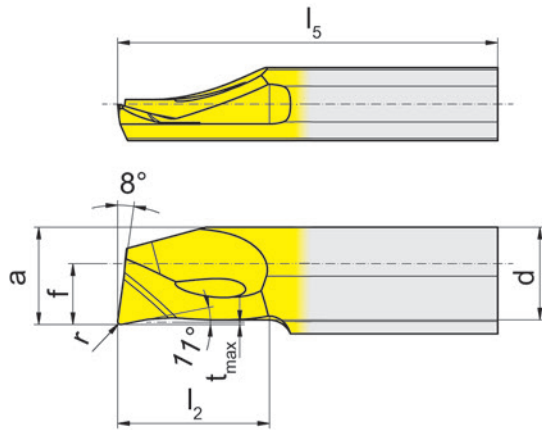
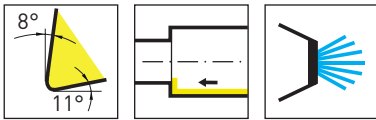

R = version à droite représentée  
R = versione destra come in figura

L = version à gauche  
L = versione sinistra a specchio

▲ en stock  
▲ a stock

Nuance  
Leghe  
Δ 4 semaines  
4 settimane

Numéro de commande Codice prodotto	r	f	a	d	b	l <sub>2</sub>	l <sub>5</sub>	t <sub>max</sub>	D <sub>min</sub>	HIS	Nuance Leghe				
											EG35	IG35	TH35		
R105.1040.1.7	0,2	4	6,4	6,1	7	10	25	0,15	6,8	105125	▲	▲	▲		
R105.1040.2.7	0,2	4	6,4	6,1	7	15	30	0,15	6,8	105125	▲	▲	▲		
R105.1040.3.7	0,2	4	6,4	6,1	7	20	35	0,15	6,8	105125	▲	▲	▲		
R105.1040.4.7	0,2	4	6,4	6,1	7	25	40	0,15	6,8	105125	▲	▲	▲		
R105.1040.5.7	0,2	4	6,4	6,1	7	30	45	0,15	6,8	105125	▲	▲	▲		
R105.1040.6.7	0,2	4	6,4	6,1	7	35	50	0,15	6,8	105125	▲	▲	▲		
L105.1040.1.7	0,2	4	6,4	6,1	7	10	25	0,15	6,8	105125	Δ		▲		
L105.1040.2.7	0,2	4	6,4	6,1	7	15	30	0,15	6,8	105125	Δ		▲		
L105.1040.3.7	0,2	4	6,4	6,1	7	20	35	0,15	6,8	105125	Δ		▲		
L105.1040.4.7	0,2	4	6,4	6,1	7	25	40	0,15	6,8	105125	Δ		▲		
L105.1040.5.7	0,2	4	6,4	6,1	7	30	45	0,15	6,8	105125	Δ		▲		
L105.1040.6.7	0,2	4	6,4	6,1	7	35	50	0,15	6,8	105125	Δ		▲		
Version renforcée Versione rinforzata												P	●	-	●
												M	●	●	●
												K	○	-	●
												N	-	-	●
												S	-	●	●
												H	-	-	-

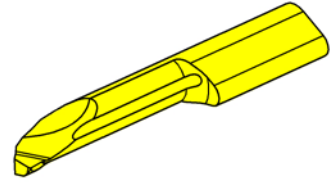
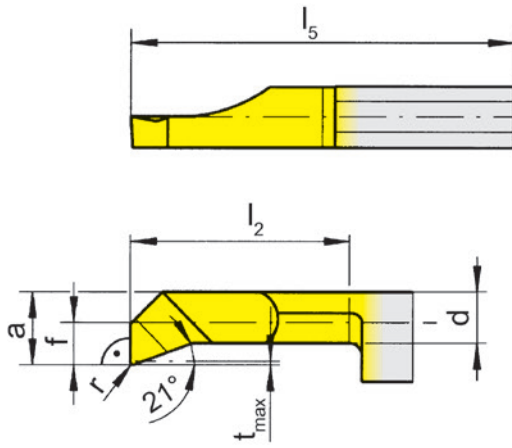
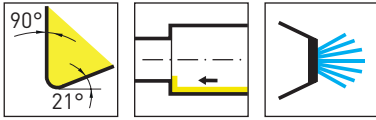

R = version à droite représentée  
R = versione destra come in figura

L = version à gauche  
L = versione sinistra a specchio

Nuance  
Leghe  
▲ en stock  
a stock  
Δ 4 semaines  
4 settimane

Numéro de commande Codice prodotto	r	f	a	d	b	l <sub>2</sub>	l <sub>5</sub>	t <sub>max</sub>	D <sub>min</sub>	HIS	Nuance / Leghe			
											EG35	IG35	TH35	TN35
R105.9013.01.1.3	0,1	1,3	2,6	2,3	5,9	10	25	0,15	3	105123	Δ	▲	▲	
R105.9013.01.2.3	0,1	1,3	2,6	2,3	5,9	15	30	0,15	3	105123	Δ	▲	▲	
R105.9013.01.3.3	0,1	1,3	2,6	2,3	5,9	20	35	0,15	3	105123	▲	▲	Δ	
R105.9013.1.3	0,2	1,3	2,6	2,3	5,9	10	25	0,15	3	105123	▲	▲		▲
R105.9013.2.3	0,2	1,3	2,6	2,3	5,9	15	30	0,15	3	105123	▲	▲		▲
R105.9019.01.1.4	0,1	1,9	3,7	2,9	6,4	10	25	0,3	4	105124	Δ	▲	▲	
R105.9019.01.2.4	0,1	1,9	3,7	2,9	6,4	15	30	0,3	4	105124	Δ	▲	▲	
R105.9019.01.3.4	0,1	1,9	3,7	2,9	6,4	20	35	0,3	4	105124	▲	▲	▲	
R105.9019.1.4	0,2	1,9	3,7	2,9	6,4	10	25	0,3	4	105124	▲	▲		▲
R105.9019.2.4	0,2	1,9	3,7	2,9	6,4	15	30	0,3	4	105124	▲	▲		▲
L105.9013.01.1.3	0,1	1,3	2,6	2,3	5,9	10	25	0,15	3	105123	Δ		▲	
L105.9013.01.2.3	0,1	1,3	2,6	2,3	5,9	15	30	0,15	3	105123	Δ		Δ	
L105.9013.01.3.3	0,1	1,3	2,6	2,3	5,9	20	35	0,15	3	105123	Δ		Δ	
L105.9013.1.3	0,2	1,3	2,6	2,3	5,9	10	25	0,15	3	105123	▲			▲
L105.9013.2.3	0,2	1,3	2,6	2,3	5,9	15	30	0,15	3	105123	▲			▲
L105.9019.01.1.4	0,1	1,9	3,7	2,9	6,4	10	25	0,3	4	105124	Δ		Δ	
L105.9019.01.2.4	0,1	1,9	3,7	2,9	6,4	15	30	0,3	4	105124	Δ		Δ	
L105.9019.01.3.4	0,1	1,9	3,7	2,9	6,4	20	35	0,3	4	105124	Δ		Δ	
L105.9019.1.4	0,2	1,9	3,7	2,9	6,4	10	25	0,3	4	105124	▲			▲
L105.9019.2.4	0,2	1,9	3,7	2,9	6,4	15	30	0,3	4	105124	▲			▲
P	●	-	●	●										
M	●	●	●	●										
K	○	-	●	●										
N	-	-	●	●										
S	-	●	●	●										
H	-	-	-	-										

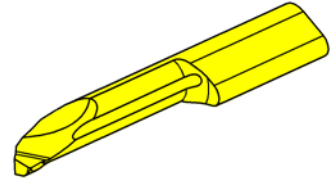
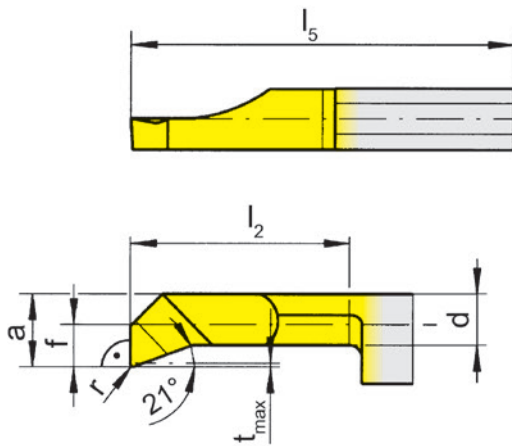
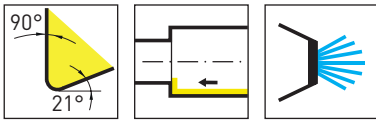

R = version à droite représentée  
R = versione destra come in figura

L = version à gauche  
L = versione sinistra a specchio

▲ en stock  
a stock

Nuance  
Leghe  
Δ 4 semaines  
4 settimane

Numéro de commande Codice prodotto	r	f	a	d	b	l <sub>2</sub>	l <sub>5</sub>	t <sub>max</sub>	D <sub>min</sub>	HIS	Nuance / Leghe			
											EG35	IG35	TH35	TN35
R105.9023.01.1.5	0,1	2,3	4,7	4	7	10	25	0,5	5	105125	▲	▲	▲	
R105.9023.01.2.5	0,1	2,3	4,7	4	7	15	30	0,5	5	105125	▲	▲	▲	
R105.9023.01.3.5	0,1	2,3	4,7	4	7	20	35	0,5	5	105125	▲	▲	▲	
R105.9023.01.4.5	0,1	2,3	4,7	4	7	25	40	0,5	5	105125	Δ	▲	▲	
R105.9023.1.5	0,2	2,3	4,7	4	7	10	25	0,5	5	105125	▲	▲	▲	▲
R105.9023.2.5	0,2	2,3	4,7	4	7	15	30	0,5	5	105125	▲	▲	▲	▲
R105.9023.3.5	0,2	2,3	4,7	4	7	20	35	0,5	5	105125	▲	▲		▲
R105.9033.1.6	0,2	3,3	5,7	4,7	7	10	25	0,5	6	105125	Δ	▲	▲	
R105.9033.2.6	0,2	3,3	5,7	4,7	7	15	30	0,5	6	105125	Δ	▲	▲	
R105.9033.3.6	0,2	3,3	5,7	4,7	7	20	35	0,5	6	105125	Δ	▲	▲	
R105.9033.4.6	0,2	3,3	5,7	4,7	7	25	40	0,5	6	105125	Δ	▲	▲	
R105.9033.5.6	0,2	3,3	5,7	4,7	7	30	45	0,5	6	105125	Δ	▲	▲	
L105.9023.01.1.5	0,1	2,3	4,7	4	7	10	25	0,5	5	105125	Δ		Δ	
L105.9023.01.2.5	0,1	2,3	4,7	4	7	15	30	0,5	5	105125	Δ		▲	
L105.9023.01.3.5	0,1	2,3	4,7	4	7	20	35	0,5	5	105125	Δ		▲	
L105.9023.01.4.5	0,1	2,3	4,7	4	7	25	40	0,5	5	105125	Δ		Δ	
L105.9023.1.5	0,2	2,3	4,7	4	7	10	25	0,5	5	105125	▲			▲
L105.9023.2.5	0,2	2,3	4,7	4	7	15	30	0,5	5	105125	▲			▲
L105.9023.3.5	0,2	2,3	4,7	4	7	20	35	0,5	5	105125				▲
L105.9033.1.6	0,2	3,3	5,7	4,7	7	10	25	0,5	6	105125	Δ			
L105.9033.2.6	0,2	3,3	5,7	4,7	7	15	30	0,5	6	105125	Δ		Δ	
L105.9033.3.6	0,2	3,3	5,7	4,7	7	20	35	0,5	6	105125	Δ		▲	
L105.9033.4.6	0,2	3,3	5,7	4,7	7	25	40	0,5	6	105125	Δ		Δ	
L105.9033.5.6	0,2	3,3	5,7	4,7	7	30	45	0,5	6	105125	Δ		▲	
P	●	-	●	●	●									
M	●	●	●	●	●									
K	○	-	●	●	●									
N	-	-	●	●	●									
S	-	●	●	●	●									
H	-	-	-	-	-									

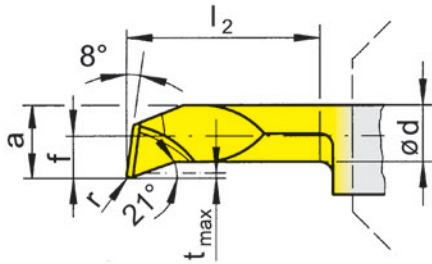
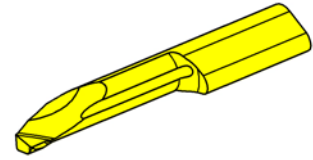
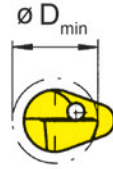
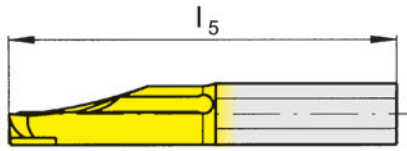
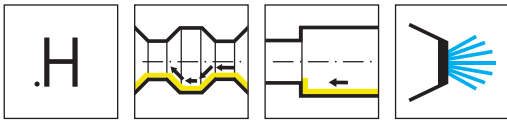

R = version à droite représentée  
R = versione destra come in figura

L = version à gauche  
L = versione sinistra a specchio

▲ en stock  
a stock

Nuance  
Leghe  
Δ 4 semaines  
4 settimane

Numéro de commande Codice prodotto	r	f	a	d	b	l <sub>2</sub>	l <sub>5</sub>	t <sub>max</sub>	D <sub>min</sub>	HIS	Nuance	
											EG35	TH35
R105.1819.1.H.4	0,2	1,9	3,7	2,9	7	10	25	0,3	4	105125	Δ	▲
R105.1819.2.H.4	0,2	1,9	3,7	2,9	7	15	30	0,3	4	105125	▲	▲
R105.1819.3.H.4	0,2	1,9	3,7	2,9	7	20	35	0,3	4	105125	Δ	▲
R105.1823.1.H.5	0,2	2,3	4,7	4	7	10	25	0,5	5	105125	▲	▲
R105.1823.2.H.5	0,2	2,3	4,7	4	7	15	30	0,5	5	105125	▲	▲
R105.1823.3.H.5	0,2	2,3	4,7	4	7	20	35	0,5	5	105125	▲	▲
R105.1823.4.H.5	0,2	2,3	4,7	4	7	25	40	0,5	5	105125	▲	▲
R105.1823.5.H.5	0,2	2,3	4,7	4	7	30	45	0,5	5	105125	Δ	▲
L105.1819.1.H.4	0,2	1,9	3,7	2,9	7	10	25	0,3	4	105125	Δ	▲
L105.1819.2.H.4	0,2	1,9	3,7	2,9	7	15	30	0,3	4	105125	Δ	Δ
L105.1819.3.H.4	0,2	1,9	3,7	2,9	7	20	35	0,3	4	105125	Δ	▲
L105.1823.1.H.5	0,2	2,3	4,7	4	7	10	25	0,5	5	105125	Δ	▲
L105.1823.2.H.5	0,2	2,3	4,7	4	7	15	30	0,5	5	105125	Δ	Δ
L105.1823.3.H.5	0,2	2,3	4,7	4	7	20	35	0,5	5	105125	Δ	▲
L105.1823.4.H.5	0,2	2,3	4,7	4	7	25	40	0,5	5	105125	Δ	Δ
L105.1823.5.H.5	0,2	2,3	4,7	4	7	30	45	0,5	5	105125	Δ	Δ
P	●	●										
M	●	●										
K	○	●										
N	-	●										
S	-	●										
H	-	-										

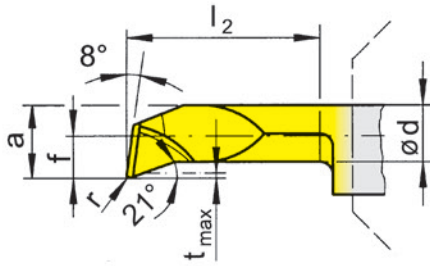
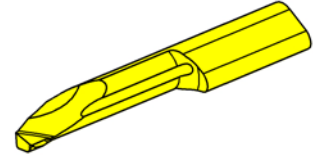
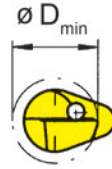
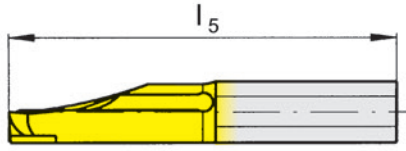
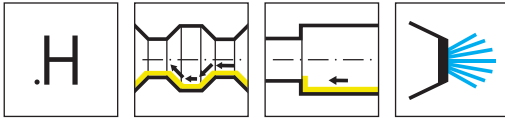

R = version à droite représentée  
R = versione destra come in figura

L = version à gauche  
L = versione sinistra a specchio

▲ en stock  
a stock

Nuance  
Leghe  
Δ 4 semaines  
4 settimane

Numéro de commande Codice prodotto	r	f	a	d	b	l <sub>2</sub>	l <sub>5</sub>	t <sub>max</sub>	D <sub>min</sub>	HIS	Nuance	
											EG35	TH35
R105.1833.2.H.6	0,2	3,3	5,7	4,7	7	15	30	0,5	6	105125	Δ	▲
R105.1833.3.H.6	0,2	3,3	5,7	4,7	7	20	35	0,5	6	105125	Δ	▲
R105.1833.4.H.6	0,2	3,3	5,7	4,7	7	25	40	0,5	6	105125	Δ	▲
R105.1833.5.H.6	0,2	3,3	5,7	4,7	7	30	45	0,5	6	105125	Δ	▲
R105.1840.3.H.7	0,2	4	6,4	5,2	7	20	35	0,5	7	105125	▲	▲
R105.1840.4.H.7	0,2	4	6,4	5,2	7	25	40	0,5	7	105125	Δ	▲
R105.1840.5.H.7	0,2	4	6,4	5,2	7	30	45	0,5	7	105125	Δ	▲
L105.1833.2.H.6	0,2	3,3	5,7	4,7	7	15	30	0,5	6	105125	Δ	Δ
L105.1833.3.H.6	0,2	3,3	5,7	4,7	7	20	35	0,5	6	105125	Δ	Δ
L105.1833.4.H.6	0,2	3,3	5,7	4,7	7	25	40	0,5	6	105125	Δ	Δ
L105.1833.5.H.6	0,2	3,3	5,7	4,7	7	30	45	0,5	6	105125	Δ	Δ
L105.1840.3.H.7	0,2	4	6,4	5,2	7	20	35	0,5	7	105125	Δ	▲
L105.1840.4.H.7	0,2	4	6,4	5,2	7	25	40	0,5	7	105125	Δ	Δ
L105.1840.5.H.7	0,2	4	6,4	5,2	7	30	45	0,5	7	105125	Δ	▲

P	●	●
M	●	●
K	○	●
N	-	●
S	-	●
H	-	-

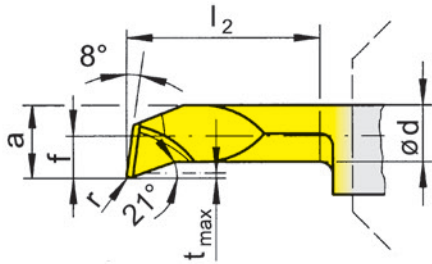
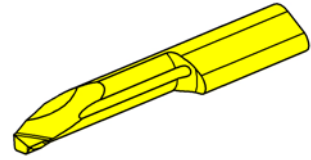
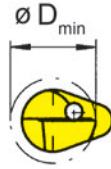
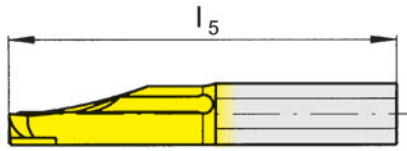
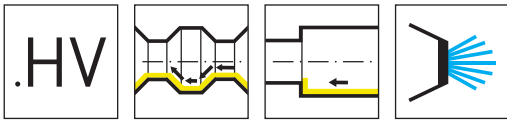

R = version à droite représentée  
R = versione destra come in figura

L = version à gauche  
L = versione sinistra a specchio

▲ en stock  
▲ a stock

Nuance  
Leghe  
Δ 4 semaines  
4 settimane

Numéro de commande Codice prodotto	r	f	a	d	b	l <sub>2</sub>	l <sub>5</sub>	t <sub>max</sub>	D <sub>min</sub>	HIS	Nuance		
											EG35	TH35	
R105.1819.1.HV4	0,2	1,9	3,7	2,9	7	10	25	0,3	4	105125	Δ	▲	
R105.1819.2.HV4	0,2	1,9	3,7	2,9	7	15	30	0,3	4	105125	Δ	▲	
R105.1819.3.HV4	0,2	1,9	3,7	2,9	7	20	35	0,3	4	105125	Δ	▲	
R105.1823.1.HV5	0,2	2,3	4,7	4	7	10	25	0,5	5	105125	Δ	▲	
R105.1823.2.HV5	0,2	2,3	4,7	4	7	15	30	0,5	5	105125	▲	▲	
R105.1823.3.HV5	0,2	2,3	4,7	4	7	20	35	0,5	5	105125	▲	▲	
R105.1823.4.HV5	0,2	2,3	4,7	4	7	25	40	0,5	5	105125	Δ	▲	
R105.1823.5.HV5	0,2	2,3	4,7	4	7	30	45	0,5	5	105125	▲	▲	
L105.1819.1.HV4	0,2	1,9	3,7	2,9	7	10	25	0,3	4	105125	Δ	Δ	
L105.1819.2.HV4	0,2	1,9	3,7	2,9	7	15	30	0,3	4	105125	Δ	▲	
L105.1819.3.HV4	0,2	1,9	3,7	2,9	7	20	35	0,3	4	105125	Δ	▲	
L105.1823.1.HV5	0,2	2,3	4,7	4	7	10	25	0,5	5	105125	Δ	▲	
L105.1823.2.HV5	0,2	2,3	4,7	4	7	15	30	0,5	5	105125	Δ	▲	
L105.1823.3.HV5	0,2	2,3	4,7	4	7	20	35	0,5	5	105125	Δ	▲	
L105.1823.4.HV5	0,2	2,3	4,7	4	7	25	40	0,5	5	105125	Δ	Δ	
L105.1823.5.HV5	0,2	2,3	4,7	4	7	30	45	0,5	5	105125	Δ	Δ	
											P	●	●
											M	●	●
											K	○	●
											N	-	●
											S	-	●
											H	-	-

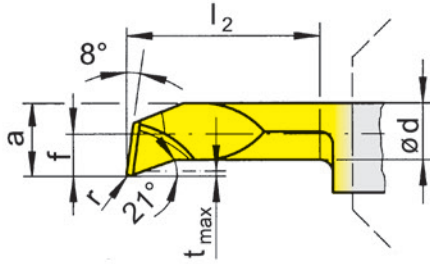
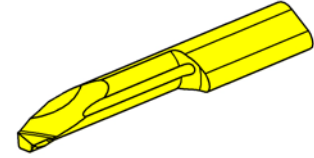
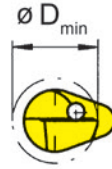
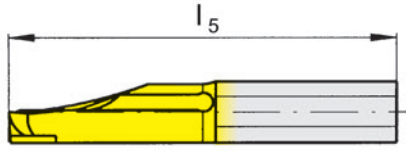
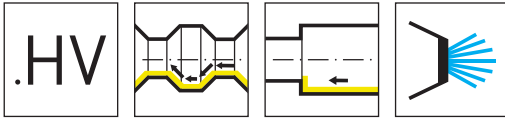

R = version à droite représentée  
R = versione destra come in figura

L = version à gauche  
L = versione sinistra a specchio

▲ en stock  
a stock

Nuance  
Leghe  
Δ 4 semaines  
4 settimane

Numéro de commande Codice prodotto	r	f	a	d	b	l <sub>2</sub>	l <sub>5</sub>	t <sub>max</sub>	D <sub>min</sub>	HIS	Material	
											EG35	TH35
R105.1819.04.1.HV4	0,4	1,9	3,7	2,9	7	10	25	0,3	4	105125	▲	▲
R105.1819.04.2.HV4	0,4	1,9	3,7	2,9	7	15	30	0,3	4	105125	▲	▲
R105.1819.04.3.HV4	0,4	1,9	3,7	2,9	7	20	35	0,3	4	105125	Δ	▲
R105.1823.04.1.HV5	0,4	2,3	4,7	4	7	10	25	0,5	5	105125	Δ	▲
R105.1823.04.2.HV5	0,4	2,3	4,7	4	7	15	30	0,5	5	105125	▲	▲
R105.1823.04.3.HV5	0,4	2,3	4,7	4	7	20	35	0,5	5	105125	Δ	▲
R105.1823.04.4.HV5	0,4	2,3	4,7	4	7	25	40	0,5	5	105125	Δ	▲
R105.1823.04.5.HV5	0,4	2,3	4,7	4	7	30	45	0,5	5	105125	Δ	▲
L105.1819.04.1.HV4	0,4	1,9	3,7	2,9	7	10	25	0,3	4	105125	Δ	▲
L105.1819.04.2.HV4	0,4	1,9	3,7	2,9	7	15	30	0,3	4	105125	Δ	Δ
L105.1819.04.3.HV4	0,4	1,9	3,7	2,9	7	20	35	0,3	4	105125	Δ	Δ
L105.1823.04.1.HV5	0,4	2,3	4,7	4	7	10	25	0,5	5	105125	Δ	▲
L105.1823.04.2.HV5	0,4	2,3	4,7	4	7	15	30	0,5	5	105125	Δ	Δ
L105.1823.04.3.HV5	0,4	2,3	4,7	4	7	20	35	0,5	5	105125	Δ	Δ
L105.1823.04.4.HV5	0,4	2,3	4,7	4	7	25	40	0,5	5	105125	Δ	Δ
L105.1823.04.5.HV5	0,4	2,3	4,7	4	7	30	45	0,5	5	105125	Δ	▲
P	●	●										
M	●	●										
K	○	●										
N	-	●										
S	-	●										
H	-	-										

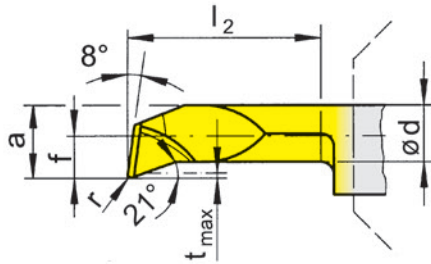
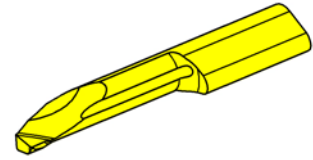
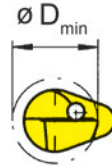
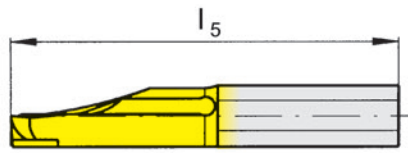
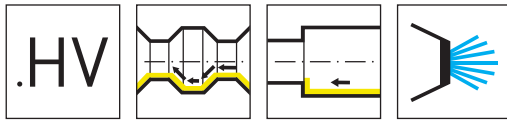

R = version à droite représentée  
R = versione destra come in figura

L = version à gauche  
L = versione sinistra a specchio

▲ en stock  
a stock

Nuance  
Leghe  
Δ 4 semaines  
4 settimane

Numéro de commande Codice prodotto	r	f	a	d	b	l <sub>2</sub>	l <sub>5</sub>	t <sub>max</sub>	D <sub>min</sub>	HIS	Nuance		
											EG35	TH35	
R105.1833.2.HV6	0,2	3,3	5,7	4,7	7	15	30	0,5	6	105125	Δ	▲	
R105.1833.3.HV6	0,2	3,3	5,7	4,7	7	20	35	0,5	6	105125	▲	▲	
R105.1833.4.HV6	0,2	3,3	5,7	4,7	7	25	40	0,5	6	105125	Δ	▲	
R105.1833.5.HV6	0,2	3,3	5,7	4,7	7	30	45	0,5	6	105125	Δ	▲	
R105.1840.2.HV7	0,2	4	6,4	5,2	7	15	30	0,5	7	105125	Δ	▲	
R105.1840.3.HV7	0,2	4	6,4	5,2	7	20	35	0,5	7	105125	Δ	▲	
R105.1840.4.HV7	0,2	4	6,4	5,2	7	25	40	0,5	7	105125	▲	▲	
R105.1840.5.HV7	0,2	4	6,4	5,2	7	30	45	0,5	7	105125	Δ	▲	
L105.1833.2.HV6	0,2	3,3	5,7	4,7	7	15	30	0,5	6	105125	Δ	▲	
L105.1833.3.HV6	0,2	3,3	5,7	4,7	7	20	35	0,5	6	105125	Δ	Δ	
L105.1833.4.HV6	0,2	3,3	5,7	4,7	7	25	40	0,5	6	105125	▲	▲	
L105.1833.5.HV6	0,2	3,3	5,7	4,7	7	30	45	0,5	6	105125	Δ	Δ	
L105.1840.2.HV7	0,2	4	6,4	5,2	7	15	30	0,5	7	105125	Δ	▲	
L105.1840.3.HV7	0,2	4	6,4	5,2	7	20	35	0,5	7	105125		Δ	
L105.1840.4.HV7	0,2	4	6,4	5,2	7	25	40	0,5	7	105125	Δ	Δ	
L105.1840.5.HV7	0,2	4	6,4	5,2	7	30	45	0,5	7	105125	Δ	Δ	
											P	●	●
											M	●	●
											K	○	●
											N	-	●
											S	-	●
											H	-	-

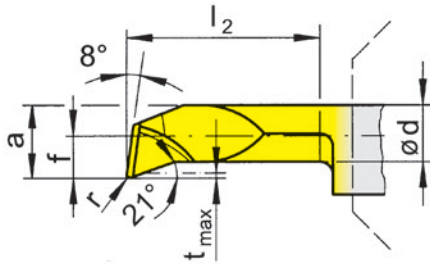
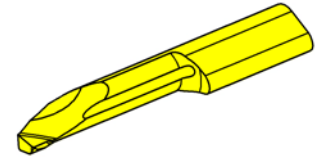
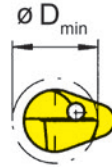
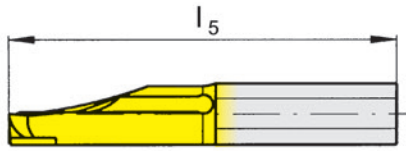
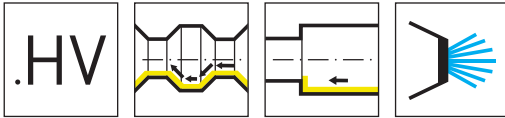

R = version à droite représentée  
R = versione destra come in figura

L = version à gauche  
L = versione sinistra a specchio

▲ en stock  
a stock

Nuance  
Leghe  
Δ 4 semaines  
4 settimane

Numéro de commande Codice prodotto	r	f	a	d	b	l <sub>2</sub>	l <sub>5</sub>	t <sub>max</sub>	D <sub>min</sub>	HIS	Nuance		
											EG35	TH35	
R105.1833.04.2.HV6	0,4	3,3	5,7	4,7	7	15	30	0,5	6	105125	Δ	▲	
R105.1833.04.3.HV6	0,4	3,3	5,7	4,7	7	20	35	0,5	6	105125	▲	▲	
R105.1833.04.4.HV6	0,4	3,3	5,7	4,7	7	25	40	0,5	6	105125	Δ	▲	
R105.1833.04.5.HV6	0,4	3,3	5,7	4,7	7	30	45	0,5	6	105125	Δ	▲	
R105.1840.04.2.HV7	0,4	4	6,4	5,2	7	15	30	0,5	7	105125	Δ	▲	
R105.1840.04.3.HV7	0,4	4	6,4	5,2	7	20	35	0,5	7	105125	Δ	▲	
R105.1840.04.4.HV7	0,4	4	6,4	5,2	7	25	40	0,5	7	105125	Δ	▲	
R105.1840.04.5.HV7	0,4	4	6,4	5,2	7	30	45	0,5	7	105125	Δ	▲	
L105.1833.04.2.HV6	0,4	3,3	5,7	4,7	7	15	30	0,5	6	105125		▲	
L105.1833.04.3.HV6	0,4	3,3	5,7	4,7	7	20	35	0,5	6	105125	Δ	Δ	
L105.1833.04.4.HV6	0,4	3,3	5,7	4,7	7	25	40	0,5	6	105125	Δ	Δ	
L105.1833.04.5.HV6	0,4	3,3	5,7	4,7	7	30	45	0,5	6	105125	Δ	Δ	
L105.1840.04.2.HV7	0,4	4	6,4	5,2	7	15	30	0,5	7	105125	Δ	▲	
L105.1840.04.3.HV7	0,4	4	6,4	5,2	7	20	35	0,5	7	105125	Δ	▲	
L105.1840.04.4.HV7	0,4	4	6,4	5,2	7	25	40	0,5	7	105125	Δ	Δ	
L105.1840.04.5.HV7	0,4	4	6,4	5,2	7	30	45	0,5	7	105125		Δ	
											P	●	●
											M	●	●
											K	○	●
											N	-	●
											S	-	●
											H	-	-

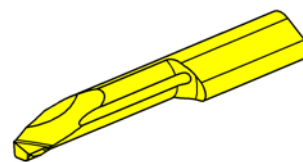
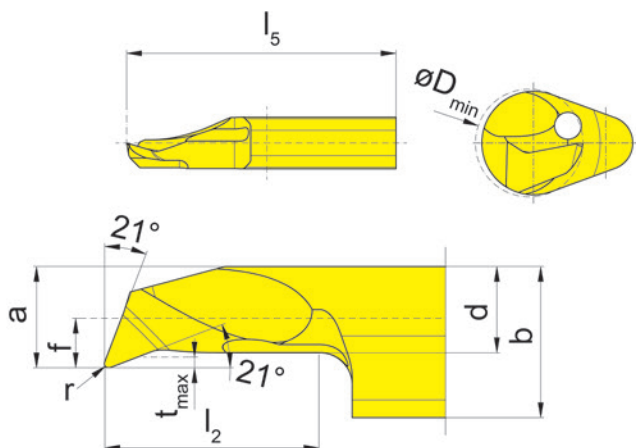
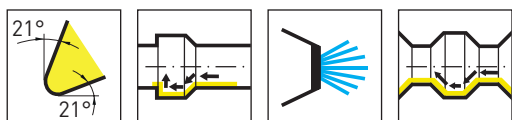

Nuance  
Leghe

R = version à droite représentée  
R = versione destra come in figura

L = version à gauche  
L = versione sinistra a specchio

▲ en stock  
a stock

Δ 4 semaines  
4 settimane

Numéro de commande Codice prodotto	r	f	a	d	b	l <sub>2</sub>	l <sub>5</sub>	t <sub>max</sub>	D <sub>min</sub>	HIS		
											EG35	IG35
R105.2113.1.3	0,1	1,3	2,6	2,3	5,9	10	25	0,15	3	105123	▲	▲
R105.2113.2.3	0,1	1,3	2,6	2,3	5,9	15	30	0,15	3	105123	▲	▲
R105.2113.3.3	0,1	1,3	2,6	2,3	5,9	20	35	0,15	3	105123	▲	▲
R105.2119.1.4	0,15	1,9	3,7	3	6,4	10	25	0,3	4	105124	▲	▲
R105.2119.2.4	0,15	1,9	3,7	3	6,4	15	30	0,3	4	105124	▲	▲
R105.2119.3.4	0,15	1,9	3,7	3	6,4	20	35	0,3	4	105124	▲	▲
R105.2119.4.4	0,15	1,9	3,7	3	6,4	25	40	0,3	4	105124	Δ	▲
R105.2123.1.5	0,2	2,3	4,7	4	7	10	25	0,5	5	105125	Δ	▲
R105.2123.2.5	0,2	2,3	4,7	4	7	15	30	0,5	5	105125	▲	▲
R105.2123.3.5	0,2	2,3	4,7	4	7	20	35	0,5	5	105125	▲	▲
R105.2123.4.5	0,2	2,3	4,7	4	7	25	40	0,5	5	105125	Δ	▲
R105.2123.5.5	0,2	2,3	4,7	4	7	30	45	0,5	5	105125	Δ	▲
R105.2123.6.5	0,2	2,3	4,7	4	7	35	50	0,5	5	105125	▲	▲
L105.2113.1.3	0,1	1,3	2,6	2,3	5,9	10	25	0,15	3	105123	▲	
L105.2113.2.3	0,1	1,3	2,6	2,3	5,9	15	30	0,15	3	105123	▲	
L105.2113.3.3	0,1	1,3	2,6	2,3	5,9	20	35	0,15	3	105123	▲	
L105.2119.1.4	0,15	1,9	3,7	3	6,4	10	25	0,3	4	105124	▲	
L105.2119.2.4	0,15	1,9	3,7	3	6,4	15	30	0,3	4	105124	Δ	
L105.2119.3.4	0,15	1,9	3,7	3	6,4	20	35	0,3	4	105124	▲	
L105.2119.4.4	0,15	1,9	3,7	3	6,4	25	40	0,3	4	105124	Δ	
L105.2123.1.5	0,2	2,3	4,7	4	7	10	25	0,5	5	105125	Δ	
L105.2123.2.5	0,2	2,3	4,7	4	7	15	30	0,5	5	105125	▲	
L105.2123.3.5	0,2	2,3	4,7	4	7	20	35	0,5	5	105125	Δ	
L105.2123.4.5	0,2	2,3	4,7	4	7	25	40	0,5	5	105125	Δ	
L105.2123.5.5	0,2	2,3	4,7	4	7	30	45	0,5	5	105125	Δ	
L105.2123.6.5	0,2	2,3	4,7	4	7	35	50	0,5	5	105125	Δ	

P	●	-
M	●	●
K	○	-
N	-	-
S	-	●
H	-	-

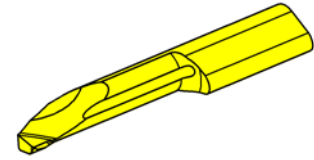
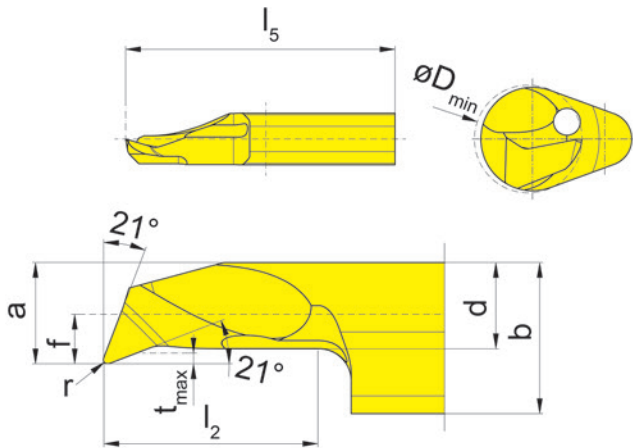
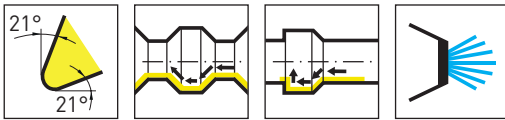

R = version à droite représentée  
R = versione destra come in figura

L = version à gauche  
L = versione sinistra a specchio

▲ en stock  
a stock

Nuance  
Leghe  
Δ 4 semaines  
4 settimane

Numéro de commande Codice prodotto	r	f	a	d	b	l <sub>2</sub>	l <sub>5</sub>	t <sub>max</sub>	D <sub>min</sub>	HIS		
											EG35	IG35
R105.2133.1.6	0,2	3,3	5,7	4,7	7	10	25	0,5	6	105125	▲	▲
R105.2133.2.6	0,2	3,3	5,7	4,7	7	15	30	0,5	6	105125	▲	▲
R105.2133.3.6	0,2	3,3	5,7	4,7	7	20	35	0,5	6	105125	▲	▲
R105.2133.4.6	0,2	3,3	5,7	4,7	7	25	40	0,5	6	105125	Δ	▲
R105.2133.5.6	0,2	3,3	5,7	4,7	7	30	45	0,5	6	105125	Δ	▲
R105.2133.6.6	0,2	3,3	5,7	4,7	7	35	50	0,5	6	105125	Δ	▲
R105.2140.1.7	0,2	4	6,4	5,2	7	10	25	0,5	7	105125	▲	▲
R105.2140.2.7	0,2	4	6,4	5,2	7	15	30	0,5	7	105125	▲	▲
R105.2140.3.7	0,2	4	6,4	5,2	7	20	35	0,5	7	105125	▲	▲
R105.2140.4.7	0,2	4	6,4	5,2	7	25	40	0,5	7	105125	Δ	▲
R105.2140.5.7	0,2	4	6,4	5,2	7	30	45	0,5	7	105125	Δ	▲
R105.2140.6.7	0,2	4	6,4	5,2	7	35	50	0,5	7	105125	Δ	▲
L105.2133.1.6	0,2	3,3	5,7	4,7	7	10	25	0,5	6	105125	▲	
L105.2133.2.6	0,2	3,3	5,7	4,7	7	15	30	0,5	6	105125	▲	
L105.2133.3.6	0,2	3,3	5,7	4,7	7	20	35	0,5	6	105125	▲	
L105.2133.4.6	0,2	3,3	5,7	4,7	7	25	40	0,5	6	105125	Δ	
L105.2133.5.6	0,2	3,3	5,7	4,7	7	30	45	0,5	6	105125	Δ	
L105.2133.6.6	0,2	3,3	5,7	4,7	7	35	50	0,5	6	105125	Δ	
L105.2140.1.7	0,2	4	6,4	5,2	7	10	25	0,5	7	105125	▲	
L105.2140.2.7	0,2	4	6,4	5,2	7	15	30	0,5	7	105125	▲	
L105.2140.3.7	0,2	4	6,4	5,2	7	20	35	0,5	7	105125	Δ	
L105.2140.4.7	0,2	4	6,4	5,2	7	25	40	0,5	7	105125	Δ	
L105.2140.5.7	0,2	4	6,4	5,2	7	30	45	0,5	7	105125	Δ	
L105.2140.6.7	0,2	4	6,4	5,2	7	35	50	0,5	7	105125	Δ	
P	●	-										
M	●	●										
K	○	-										
N	-	-										
S	-	●										
H	-	-										

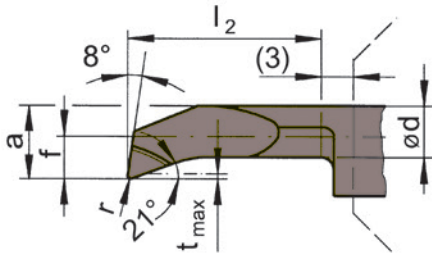
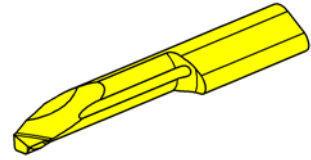
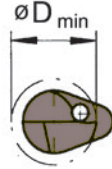
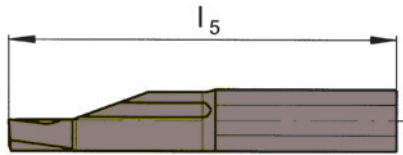
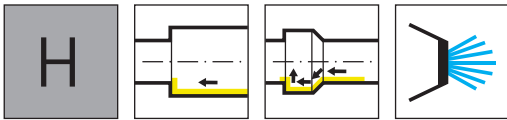

R = version à droite représentée  
R = versione destra come in figura

L = version à gauche  
L = versione sinistra a specchio

▲ en stock  
a stock

Nuance  
Leghe  
Δ 4 semaines  
4 settimane

Numéro de commande Codice prodotto	r	f	a	d	b	$l_2$	$l_5$	$t_{max}$	$D_{min}$	HIS	SG36
R105.1819.01.1.4F	0,1	1,9	3,7	2,9	6,4	10	25	0,3	4	105124	▲
R105.1819.01.2.4F	0,1	1,9	3,7	2,9	6,4	15	30	0,3	4	105124	▲
R105.1823.15.2.5F	0,15	2,3	4,7	4	7	15	30	0,5	5	105125	▲
R105.1823.15.3.5F	0,15	2,3	4,7	4	7	20	35	0,5	5	105125	▲
L105.1819.01.1.4F	0,1	1,9	3,7	2,9	6,4	10	25	0,3	4	105124	▲
L105.1819.01.2.4F	0,1	1,9	3,7	2,9	6,4	15	30	0,3	4	105124	▲
L105.1823.15.2.5F	0,15	2,3	4,7	4	7	15	30	0,5	5	105125	▲
L105.1823.15.3.5F	0,15	2,3	4,7	4	7	20	35	0,5	5	105125	▲
											P -
											M -
											K -
											N -
											S ●
											H ●

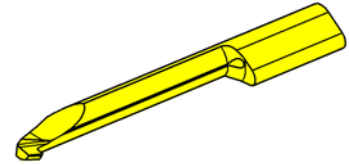
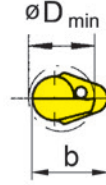
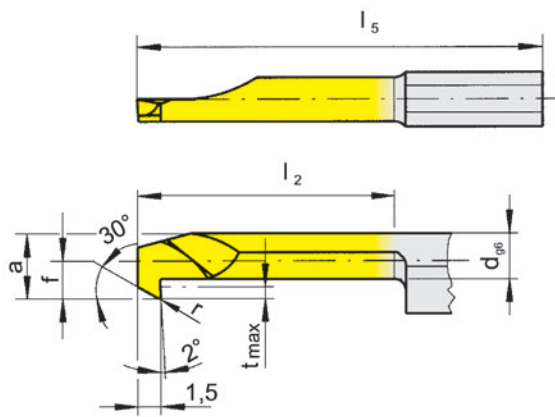
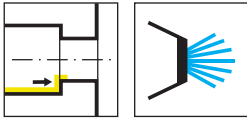

R = version à droite représentée  
R = versione destra come in figura

L = version à gauche  
L = versione sinistra a specchio

▲ en stock  
a stock

Nuance  
Leghe  
Δ 4 semaines  
4 settimane

Número de commande Codice prodotto	r	f	a	d	b	l <sub>2</sub>	l <sub>5</sub>	t <sub>max</sub>	D <sub>min</sub>	HIS	EG35	TI25
R105.3013.2.3	0,1	1,3	2,6	1,9	5,9	15	30	0,5	3	105123	▲	▲
R105.3013.3.3	0,1	1,3	2,6	1,9	5,9	20	35	0,5	3	105123	▲	▲
R105.3019.2.4	0,15	1,9	3,7	2,7	6,4	15	30	0,8	4	105124	▲	▲
R105.3019.4.4	0,15	1,9	3,7	2,7	6,4	25	40	0,8	4	105124	▲	▲
R105.3023.3.5	0,2	2,3	4,7	3,5	7	20	35	1	5	105125	▲	▲
R105.3023.5.5	0,2	2,3	4,7	3,5	7	30	45	1	5	105125	▲	▲
R105.3033.3.6	0,2	3,3	5,7	3,7	7	20	35	1,8	6	105125	▲	▲
R105.3033.5.6	0,2	3,3	5,7	3,7	7	30	45	1,8	6	105125	▲	▲
R105.3040.3.7	0,2	4	6,4	3,7	7	20	35	2,5	6,8	105125	▲	▲
R105.3040.5.7	0,2	4	6,4	3,7	7	30	45	2,5	6,8	105125	▲	▲
L105.3013.2.3	0,1	1,3	2,6	1,9	5,9	15	30	0,5	3	105123	Δ	▲
L105.3013.3.3	0,1	1,3	2,6	1,9	5,9	20	35	0,5	3	105123	Δ	Δ
L105.3019.2.4	0,15	1,9	3,7	2,7	6,4	15	30	0,8	4	105124		Δ
L105.3019.4.4	0,15	1,9	3,7	2,7	6,4	25	40	0,8	4	105124	Δ	Δ
L105.3023.3.5	0,2	2,3	4,7	3,5	7	20	35	1	5	105125	▲	▲
L105.3023.5.5	0,2	2,3	4,7	3,5	7	30	45	1	5	105125	Δ	Δ
L105.3033.3.6	0,2	3,3	5,7	3,7	7	20	35	1,8	6	105125	Δ	▲
L105.3033.5.6	0,2	3,3	5,7	3,7	7	30	45	1,8	6	105125	Δ	Δ
L105.3040.3.7	0,2	4	6,4	3,7	7	20	35	2,5	6,8	105125	▲	▲
L105.3040.5.7	0,2	4	6,4	3,7	7	30	45	2,5	6,8	105125	Δ	Δ

P	●	●
M	●	●
K	○	●
N	-	●
S	-	●
H	-	-

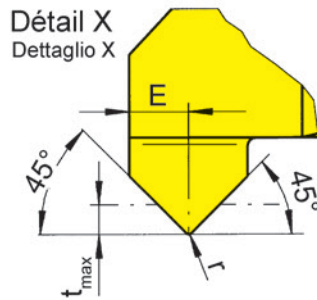
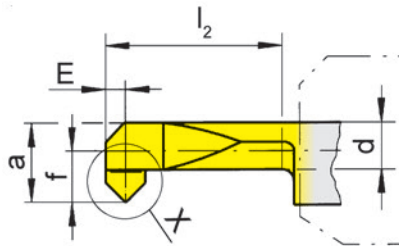
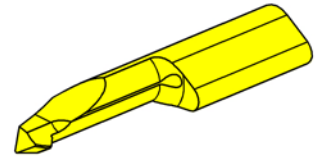
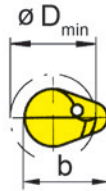
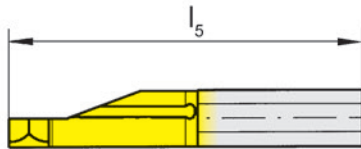
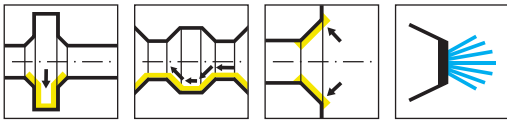

R = version à droite représentée  
R = versione destra come in figura

L = version à gauche  
L = versione sinistra a specchio

▲ en stock  
a stock

Nuance  
Leghe  
Δ 4 semaines  
4 settimane

Numéro de commande Codice prodotto	r	f	E	a	d	b	l <sub>2</sub>	l <sub>5</sub>	t <sub>max</sub>	D <sub>min</sub>	HIS	Nuance Leghe			
												EG35	TH35	TN35	
R105.4545.1.3	0,2	1,4	1	2,7	1,9	5,9	10	25	0,5	3	105123		▲		
R105.4545.1.4	0,2	1,9	1	3,7	2,8	6,4	10	25	0,7	4	105124		▲		
R105.4545.2.5	0,2	2,3	1	4,7	3,5	7	15	30	0,7	5	105125	▲		▲	
R105.4545.3.7	0,2	4	1	6,4	4,7	7	20	35	0,7	7	105125	▲		▲	
L105.4545.1.3	0,2	1,4	1	2,7	1,9	5,9	10	25	0,5	3	105123			▲	
L105.4545.1.4	0,2	1,9	1	3,7	2,8	6,4	10	25	0,7	4	105124			▲	
L105.4545.2.5	0,2	2,3	1	4,7	3,5	7	15	30	0,7	5	105125	▲		▲	
L105.4545.3.7	0,2	4	1	6,4	4,7	7	20	35	0,7	7	105125	▲		▲	
P	●	●	●	●	●	●	●	●	●	●	●	●	●	●	●
M	●	●	●	●	●	●	●	●	●	●	●	●	●	●	●
K	○	●	●	●	●	●	●	●	●	●	●	●	●	●	●
N	-	●	●	●	●	●	●	●	●	●	●	●	●	●	●
S	-	●	●	●	●	●	●	●	●	●	●	●	●	●	●
H	-	-	-	-	-	-	-	-	-	-	-	-	-	-	-

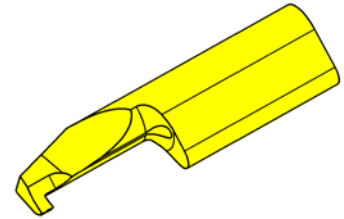
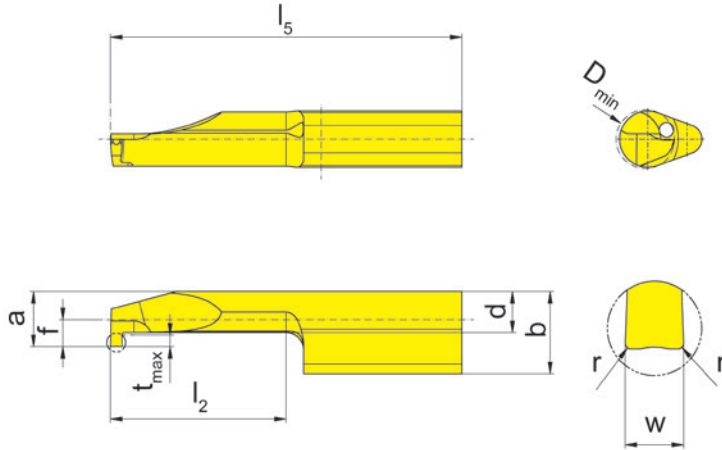

R = version à droite représentée  
R = versione destra come in figura

L = version à gauche  
L = versione sinistra a specchio

▲ en stock  
a stock

Nuance  
Leghe  
Δ 4 semaines  
4 settimane

Número de commande Codice prodotto	w	r	f	a	d	b	l <sub>2</sub>	l <sub>5</sub>	t <sub>max</sub>	D <sub>min</sub>	HIS	EG35
R105.FB10.1.01	1	0,1	2,3	4,7	3,5	7	10	25	1	5	105125	▲
R105.FB10.2.01	1	0,1	2,3	4,7	3,5	7	15	30	1	5	105125	▲
R105.FB15.1.01	1,5	0,1	2,3	4,7	3,5	7	10	25	1	5	105125	▲
R105.FB15.2.01	1,5	0,1	2,3	4,7	3,5	7	15	30	1	5	105125	▲
L105.FB10.1.01	1	0,1	2,3	4,7	3,5	7	10	25	1	5	105125	▲
L105.FB10.2.01	1	0,1	2,3	4,7	3,5	7	15	30	1	5	105125	▲
L105.FB15.1.01	1,5	0,1	2,3	4,7	3,5	7	10	25	1	5	105125	▲
L105.FB15.2.01	1,5	0,1	2,3	4,7	3,5	7	15	30	1	5	105125	▲

Calcul de la plus petite largeur de gorge possible  $w_x$   
Calcolo della larghezza di gola  $w_x$  più basso possibile

Exemple R105.FB10.01  
Esempio

$w_x = 2 \times$  Largeur de gorge  $w - 2 \times$  Rayon d'angles plaquette  $r$

$w_x = 2 \times$  Larghezza della gola  $w - 2 \times$  Spigolo raggiato inserto  $r$

$w_x = 2 \times 1 \text{ mm} - 2 \times 0,1 \text{ mm}$

$w_x = 1,8 \text{ mm}$

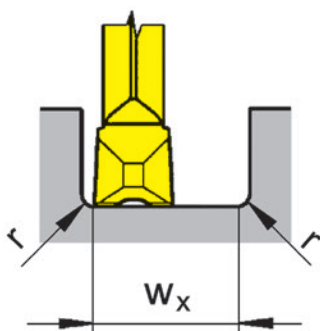

Déroulement du processus  
Percorso di lavoro

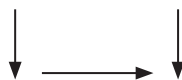

P	●
M	●
K	○
N	-
S	-
H	-

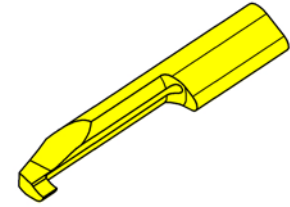
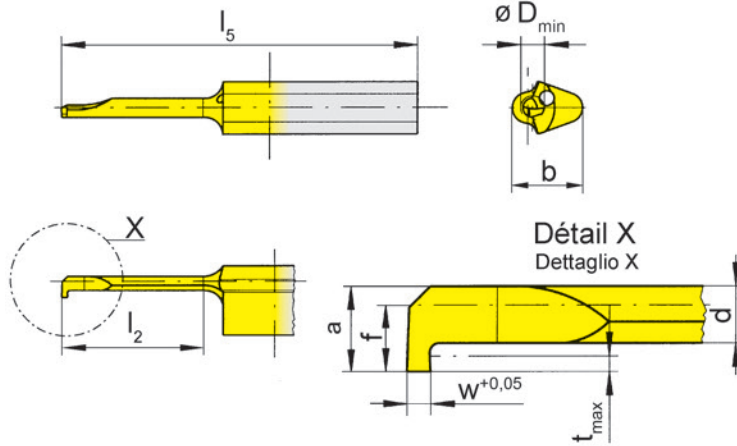
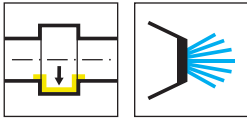

R = version à droite représentée  
R = versione destra come in figura

L = version à gauche  
L = versione sinistra a specchio

▲ en stock  
a stock

Nuance  
Leghe  
Δ 4 semaines  
4 settimane

Numéro de commande Codice prodotto	w	f	a	d	b	l <sub>2</sub>	l <sub>5</sub>	t <sub>max</sub>	D <sub>min</sub>	HIS	Nuance Leghe	
											EG35	TI25
R105.0050.0.2	0,5	1,4	1,8	1,2	5,9	6	25	0,4	2	105123	▲	▲
R105.0050.1.2	0,5	1,4	1,8	1,2	5,9	9	25	0,4	2	105123	▲	▲
R105.0050.2.2	0,5	1,4	1,8	1,2	5,9	12	30	0,4	2	105123	▲	▲
L105.0050.0.2	0,5	1,4	1,8	1,2	5,9	6	25	0,4	2	105123	▲	▲
L105.0050.1.2	0,5	1,4	1,8	1,2	5,9	9	25	0,4	2	105123	Δ	▲
L105.0050.2.2	0,5	1,4	1,8	1,2	5,9	12	30	0,4	2	105123	Δ	Δ
											P	●
											M	●
											K	●
											N	-
											S	-
											H	-

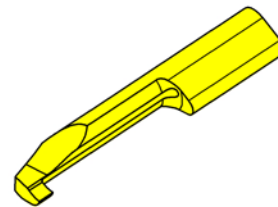
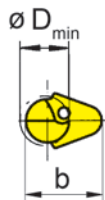
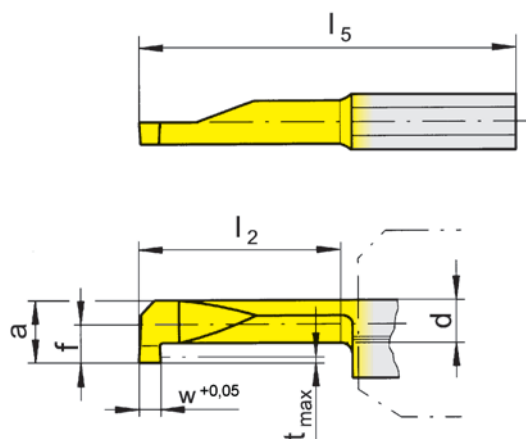
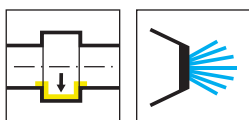

R = version à droite représentée  
R = versione destra come in figura

L = version à gauche  
L = versione sinistra a specchio

▲ en stock  
a stock

Nuance  
Leghe  
Δ 4 semaines  
4 settimane

Numéro de commande Codice prodotto	w	f	a	d	b	l <sub>2</sub>	l <sub>5</sub>	t <sub>max</sub>	D <sub>min</sub>	HIS	Nuance Leghe		
											EG35	ES15	TI25
R105.0050.1.3	0,5	1,4	2,7	2	5,9	8	25	0,5	3	105123	▲	Δ	
R105.0050.2.3	0,5	1,4	2,7	2	5,9	12	30	0,5	3	105123	Δ	Δ	
R105.0050.3.3	0,5	1,4	2,7	2	5,9	16	35	0,5	3	105123	Δ	Δ	
R105.0070.1.3	0,7	1,4	2,7	1,9	5,9	8	25	0,6	3	105123	▲		▲
R105.0070.2.3	0,7	1,4	2,7	1,9	5,9	12	30	0,6	3	105123	▲		▲
R105.0070.3.3	0,7	1,4	2,7	1,9	5,9	16	35	0,6	3	105123	▲		▲
L105.0070.1.3	0,7	1,4	2,7	1,9	5,9	8	25	0,6	3	105123	▲		▲
L105.0070.2.3	0,7	1,4	2,7	1,9	5,9	12	30	0,6	3	105123	Δ		▲
L105.0070.3.3	0,7	1,4	2,7	1,9	5,9	16	35	0,6	3	105123	Δ		▲
P	●	●	●										
M	●	●	●										
K	○	○	○										
N	-	-	●										
S	-	-	●										
H	-	-	-										

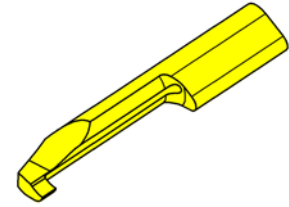
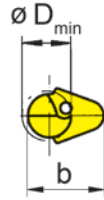
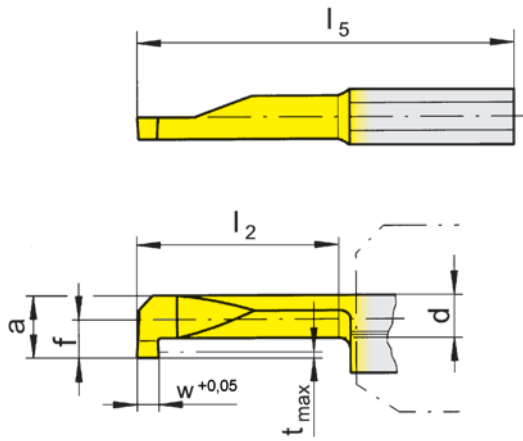
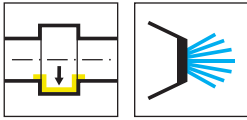

R = version à droite représentée  
R = versione destra come in figura

L = version à gauche  
L = versione sinistra a specchio

▲ en stock  
a stock

Nuance  
Leghe  
Δ 4 semaines  
4 settimane

Numéro de commande Codice prodotto	w	f	a	d	b	l <sub>2</sub>	l <sub>5</sub>	t <sub>max</sub>	D <sub>min</sub>	HIS	Nuance Leghe		
											EG35	ES15	TN35
R105.0050.1.4	0,5	1,9	3,7	2,9	6,4	10	25	0,6	4	105124	▲	▲	
R105.0050.2.4	0,5	1,9	3,7	2,9	6,4	15	30	0,6	4	105124	▲	▲	
R105.0050.3.4	0,5	1,9	3,7	2,9	6,4	20	35	0,6	4	105124	Δ	Δ	
R105.0100.1.4	1	1,9	3,7	2,7	6,4	10	25	0,8	4	105124	▲		▲
R105.0100.2.4	1	1,9	3,7	2,7	6,4	15	30	0,8	4	105124	▲		▲
R105.0100.3.4	1	1,9	3,7	2,7	6,4	20	35	0,8	4	105124	Δ		▲
L105.0100.1.4	1	1,9	3,7	2,7	6,4	10	25	0,8	4	105124	Δ		▲
L105.0100.2.4	1	1,9	3,7	2,7	6,4	15	30	0,8	4	105124	Δ		▲
L105.0100.3.4	1	1,9	3,7	2,7	6,4	20	35	0,8	4	105124	Δ		▲
P											●	●	●
M											●	●	●
K											○	○	●
N											-	-	●
S											-	-	●
H											-	-	-

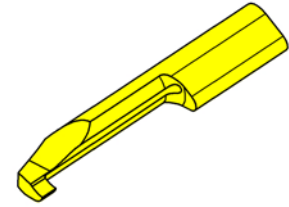
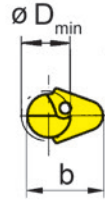
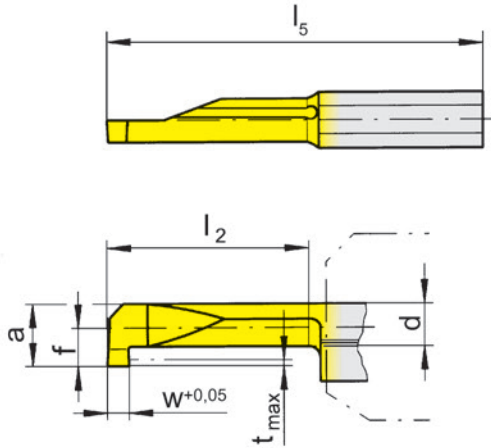
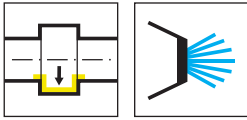

R = version à droite représentée  
R = versione destra come in figura

L = version à gauche  
L = versione sinistra a specchio

▲ en stock  
a stock

Nuance  
Leghe  
Δ 4 semaines  
4 settimane

Numéro de commande Codice prodotto	w	f	a	d	b	l <sub>2</sub>	l <sub>5</sub>	t <sub>max</sub>	D <sub>min</sub>	HIS	Nuance Leghe		
											EG35	TH35	TN35
R105.0100.1.5	1	2,3	4,7	3,5	7	10	25	1	5	105125	▲	▲	▲
R105.0100.2.5	1	2,3	4,7	3,5	7	15	30	1	5	105125	▲	▲	▲
R105.0100.3.5	1	2,3	4,7	3,5	7	20	35	1	5	105125	▲	▲	▲
R105.0150.1.5	1,5	2,3	4,7	3,5	7	10	25	1	5	105125	▲	▲	▲
R105.0150.2.5	1,5	2,3	4,7	3,5	7	15	30	1	5	105125	▲	▲	▲
R105.0150.3.5	1,5	2,3	4,7	3,5	7	20	35	1	5	105125	▲	▲	▲
R105.0200.1.5	2	2,3	4,7	3,5	7	10	25	1	5	105125	▲	▲	▲
R105.0200.2.5	2	2,3	4,7	3,5	7	15	30	1	5	105125	▲	▲	▲
R105.0200.3.5	2	2,3	4,7	3,5	7	20	35	1	5	105125	▲	▲	▲
L105.0100.1.5	1	2,3	4,7	3,5	7	10	25	1	5	105125	▲	▲	▲
L105.0100.2.5	1	2,3	4,7	3,5	7	15	30	1	5	105125	Δ	Δ	▲
L105.0100.3.5	1	2,3	4,7	3,5	7	20	35	1	5	105125	Δ	Δ	▲
L105.0150.1.5	1,5	2,3	4,7	3,5	7	10	25	1	5	105125	Δ	Δ	▲
L105.0150.2.5	1,5	2,3	4,7	3,5	7	15	30	1	5	105125	Δ	Δ	▲
L105.0150.3.5	1,5	2,3	4,7	3,5	7	20	35	1	5	105125	Δ	Δ	▲
L105.0200.1.5	2	2,3	4,7	3,5	7	10	25	1	5	105125	Δ	▲	▲
L105.0200.2.5	2	2,3	4,7	3,5	7	15	30	1	5	105125	Δ	▲	▲
L105.0200.3.5	2	2,3	4,7	3,5	7	20	35	1	5	105125	Δ	Δ	Δ
P											●	●	●
M											●	●	●
K											○	●	●
N											-	●	●
S											-	●	●
H											-	-	-

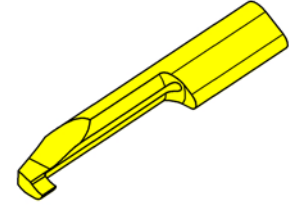
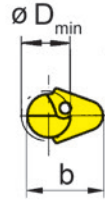
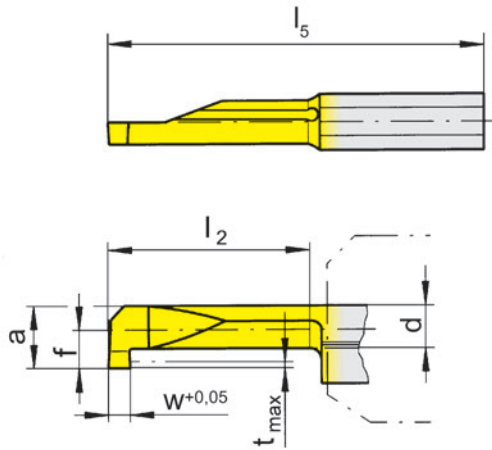
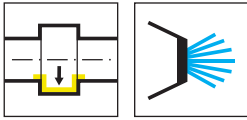

R = version à droite représentée  
R = versione destra come in figura

L = version à gauche  
L = versione sinistra a specchio

▲ en stock  
a stock

Nuance  
Leghe  
Δ 4 semaines  
4 settimane

Numéro de commande Codice prodotto	w	f	a	d	b	l <sub>2</sub>	l <sub>5</sub>	t <sub>max</sub>	D <sub>min</sub>	HIS	Nuance Leghe		
											EG35	TH35	TN35
R105.0100.4.5	1	2,3	4,7	3,5	7	25	40	1	5	105125	▲	Δ	▲
R105.0100.5.5	1	2,3	4,7	3,5	7	30	45	1	5	105125	▲	▲	▲
R105.0150.4.5	1,5	2,3	4,7	3,5	7	25	40	1	5	105125		▲	▲
R105.0150.5.5	1,5	2,3	4,7	3,5	7	30	45	1	5	105125	Δ	▲	▲
R105.0200.4.5	2	2,3	4,7	3,5	7	25	40	1	5	105125	▲	▲	▲
R105.0200.5.5	2	2,3	4,7	3,5	7	30	45	1	5	105125	Δ	▲	▲
L105.0100.4.5	1	2,3	4,7	3,5	7	25	40	1	5	105125	Δ	Δ	Δ
L105.0100.5.5	1	2,3	4,7	3,5	7	30	45	1	5	105125	Δ	Δ	Δ
L105.0150.4.5	1,5	2,3	4,7	3,5	7	25	40	1	5	105125	Δ	Δ	Δ
L105.0150.5.5	1,5	2,3	4,7	3,5	7	30	45	1	5	105125	Δ	Δ	Δ
L105.0200.4.5	2	2,3	4,7	3,5	7	25	40	1	5	105125	Δ	Δ	Δ
L105.0200.5.5	2	2,3	4,7	3,5	7	30	45	1	5	105125	Δ	Δ	Δ
P											●	●	●
M											●	●	●
K											○	●	●
N											-	●	●
S											-	●	●
H											-	-	-

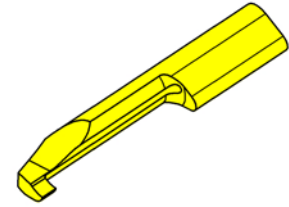
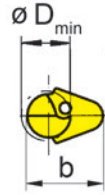
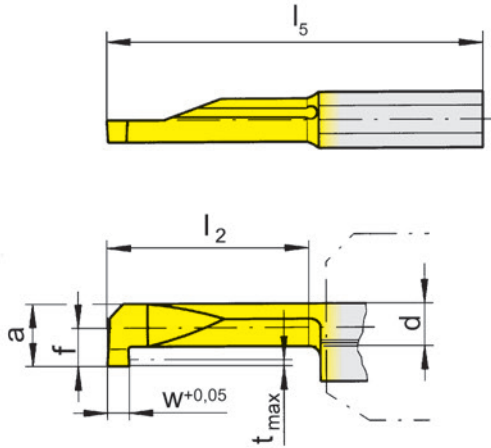
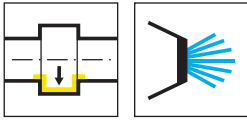

R = version à droite représentée  
R = versione destra come in figura

L = version à gauche  
L = versione sinistra a specchio

▲ en stock  
a stock

Nuance  
Leghe  
Δ 4 semaines  
4 settimane

Numéro de commande Codice prodotto	w	f	a	d	b	l <sub>2</sub>	l <sub>5</sub>	t <sub>max</sub>	D <sub>min</sub>	HIS	Nuance Leghe		
											EG35	TH35	TN35
R105.0100.1.6	1	3,3	5,7	3,7	7	10	25	1,8	6	105125	▲	▲	▲
R105.0100.2.6	1	3,3	5,7	3,7	7	15	30	1,8	6	105125	▲	▲	▲
R105.0100.3.6	1	3,3	5,7	3,7	7	20	35	1	6	105125	▲	▲	▲
R105.0150.1.6	1,5	3,3	5,7	3,7	7	10	25	1,8	6	105125	▲	▲	▲
R105.0150.2.6	1,5	3,3	5,7	3,7	7	15	30	1,8	6	105125	▲	▲	▲
R105.0150.3.6	1,5	3,3	5,7	3,7	7	20	35	1,8	6	105125	▲	▲	▲
R105.0200.1.6	2	3,3	5,7	3,7	7	10	25	1,8	6	105125	▲	▲	▲
R105.0200.2.6	2	3,3	5,7	3,7	7	15	30	1,8	6	105125	▲	▲	▲
R105.0200.3.6	2	3,3	5,7	3,7	7	20	35	1,8	6	105125	▲	▲	▲
L105.0100.1.6	1	3,3	5,7	3,7	7	10	25	1,8	6	105125	▲	▲	▲
L105.0100.2.6	1	3,3	5,7	3,7	7	15	30	1,8	6	105125	Δ	▲	▲
L105.0100.3.6	1	3,3	5,7	3,7	7	20	35	1	6	105125	Δ	▲	▲
L105.0150.1.6	1,5	3,3	5,7	3,7	7	10	25	1,8	6	105125	▲	▲	▲
L105.0150.2.6	1,5	3,3	5,7	3,7	7	15	30	1,8	6	105125	▲	▲	▲
L105.0150.3.6	1,5	3,3	5,7	3,7	7	20	35	1,8	6	105125	Δ	▲	▲
L105.0200.1.6	2	3,3	5,7	3,7	7	10	25	1,8	6	105125	▲	▲	▲
L105.0200.2.6	2	3,3	5,7	3,7	7	15	30	1,8	6	105125	▲	▲	▲
L105.0200.3.6	2	3,3	5,7	3,7	7	20	35	1,8	6	105125	▲	▲	▲
P											●	●	●
M											●	●	●
K											○	●	●
N											-	●	●
S											-	●	●
H											-	-	-

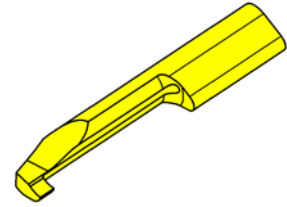
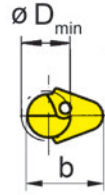
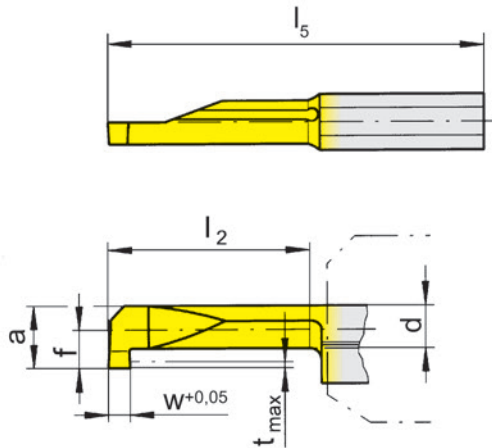
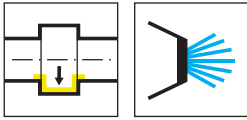

R = version à droite représentée  
R = versione destra come in figura

L = version à gauche  
L = versione sinistra a specchio

▲ en stock  
a stock

Nuance  
Leghe  
Δ 4 semaines  
4 settimane

Numéro de commande Codice prodotto	w	f	a	d	b	l <sub>2</sub>	l <sub>5</sub>	t <sub>max</sub>	D <sub>min</sub>	HIS	Nuance Leghe		
											EG35	TH35	TN35
R105.0100.4.6	1	3,3	5,7	3,7	7	25	40	1	6	105125	▲	▲	▲
R105.0100.5.6	1	3,3	5,7	3,7	7	30	45	1,8	6	105125	▲	▲	▲
R105.0150.4.6	1,5	3,3	5,7	3,7	7	25	40	1,8	6	105125	▲	▲	▲
R105.0150.5.6	1,5	3,3	5,7	3,7	7	30	45	1,8	6	105125	▲	▲	▲
R105.0200.4.6	2	3,3	5,7	3,7	7	25	40	1,8	6	105125	▲	▲	▲
R105.0200.5.6	2	3,3	5,7	3,7	7	30	45	1,8	6	105125	▲	▲	▲
L105.0100.4.6	1	3,3	5,7	3,7	7	25	40	1	6	105125	Δ	▲	Δ
L105.0100.5.6	1	3,3	5,7	3,7	7	30	45	1,8	6	105125	Δ	Δ	Δ
L105.0150.4.6	1,5	3,3	5,7	3,7	7	25	40	1,8	6	105125	Δ	Δ	▲
L105.0150.5.6	1,5	3,3	5,7	3,7	7	30	45	1,8	6	105125	Δ	Δ	▲
L105.0200.4.6	2	3,3	5,7	3,7	7	25	40	1,8	6	105125	Δ	Δ	▲
L105.0200.5.6	2	3,3	5,7	3,7	7	30	45	1,8	6	105125	Δ	Δ	▲
P											●	●	●
M											●	●	●
K											○	●	●
N											-	●	●
S											-	●	●
H											-	-	-

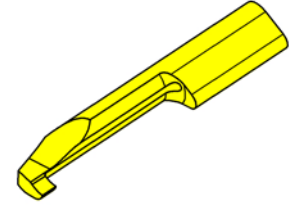
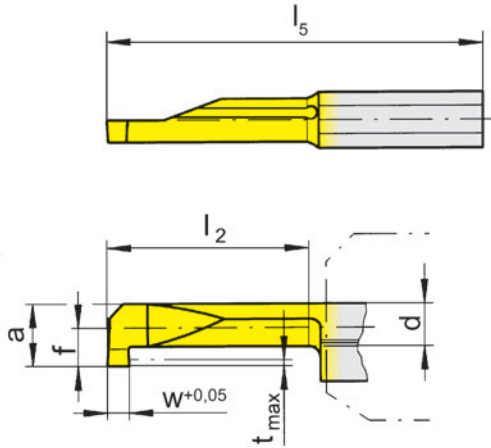
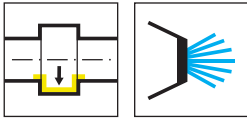

R = version à droite représentée  
R = versione destra come in figura

L = version à gauche  
L = versione sinistra a specchio

▲ en stock  
a stock

Nuance  
Leghe  
Δ 4 semaines  
4 settimane

Numéro de commande Codice prodotto	w	f	a	d	b	l <sub>2</sub>	l <sub>5</sub>	t <sub>max</sub>	D <sub>min</sub>	HIS	Nuance Leghe		
											EG35	TH35	TN35
R105.0100.1.7	1	4	6,4	3,7	7	10	25	2,5	6,8	105125	▲	▲	▲
R105.0100.2.7	1	4	6,4	3,7	7	15	30	2,5	6,8	105125	▲	▲	▲
R105.0100.3.7	1	4	6,4	3,7	7	20	35	1	6,8	105125	▲	▲	▲
R105.0150.1.7	1,5	4	6,4	3,7	7	10	25	2,5	6,8	105125	▲	▲	▲
R105.0150.2.7	1,5	4	6,4	3,7	7	15	30	2,5	6,8	105125	▲	▲	▲
R105.0150.3.7	1,5	4	6,4	3,7	7	20	35	2,5	6,8	105125	▲	▲	▲
R105.0200.1.7	2	4	6,4	3,7	7	10	25	2,5	6,8	105125	▲	▲	▲
R105.0200.2.7	2	4	6,4	3,7	7	15	30	2,5	6,8	105125	▲	▲	▲
R105.0200.3.7	2	4	6,4	3,7	7	20	35	2,5	6,8	105125	▲	▲	▲
L105.0100.1.7	1	4	6,4	3,7	7	10	25	2,5	6,8	105125	Δ	▲	▲
L105.0100.2.7	1	4	6,4	3,7	7	15	30	2,5	6,8	105125		▲	▲
L105.0100.3.7	1	4	6,4	3,7	7	20	35	1	6,8	105125	▲	▲	▲
L105.0150.1.7	1,5	4	6,4	3,7	7	10	25	2,5	6,8	105125	▲	▲	▲
L105.0150.2.7	1,5	4	6,4	3,7	7	15	30	2,5	6,8	105125		▲	▲
L105.0150.3.7	1,5	4	6,4	3,7	7	20	35	2,5	6,8	105125	▲	▲	▲
L105.0200.1.7	2	4	6,4	3,7	7	10	25	2,5	6,8	105125	▲	▲	▲
L105.0200.2.7	2	4	6,4	3,7	7	15	30	2,5	6,8	105125	Δ	▲	▲
L105.0200.3.7	2	4	6,4	3,7	7	20	35	2,5	6,8	105125	Δ	▲	▲
P											●	●	●
M											●	●	●
K											●	●	●
N											-	●	●
S											-	●	●
H											-	-	-

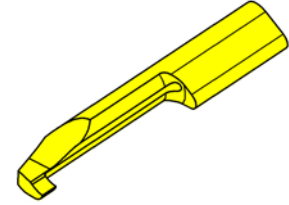
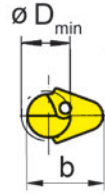
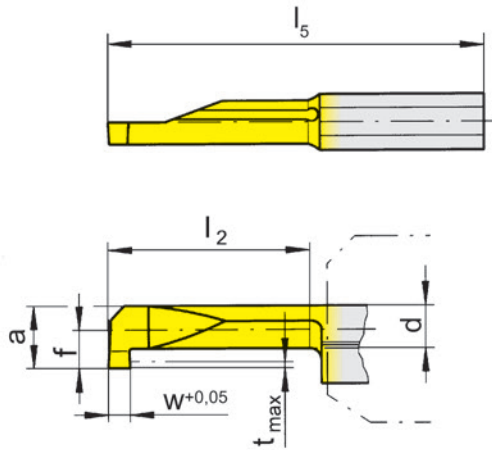
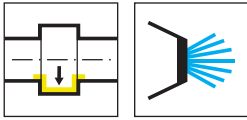

R = version à droite représentée  
R = versione destra come in figura

L = version à gauche  
L = versione sinistra a specchio

▲ en stock  
a stock

Nuance  
Leghe  
Δ 4 semaines  
4 settimane

Numéro de commande Codice prodotto	w	f	a	d	b	l <sub>2</sub>	l <sub>5</sub>	t <sub>max</sub>	D <sub>min</sub>	HIS	Nuance Leghe		
											EG35	TH35	TN35
R105.0100.4.7	1	4	6,4	3,7	7	25	40	1	6,8	105125	▲	▲	▲
R105.0100.5.7	1	4	6,4	3,7	7	30	45	2,5	6,8	105125	Δ	▲	▲
R105.0150.4.7	1,5	4	6,4	3,7	7	25	40	2,5	6,8	105125	▲	▲	▲
R105.0150.5.7	1,5	4	6,4	3,7	7	30	45	2,5	6,8	105125	▲	▲	▲
R105.0200.4.7	2	4	6,4	3,7	7	25	40	2,5	6,8	105125	▲	▲	▲
R105.0200.5.7	2	4	6,4	3,7	7	30	45	2,5	6,8	105125	▲	▲	▲
L105.0100.4.7	1	4	6,4	3,7	7	25	40	1	6,8	105125	Δ	Δ	▲
L105.0100.5.7	1	4	6,4	3,7	7	30	45	2,5	6,8	105125	Δ	▲	▲
L105.0150.4.7	1,5	4	6,4	3,7	7	25	40	2,5	6,8	105125	Δ	▲	▲
L105.0150.5.7	1,5	4	6,4	3,7	7	30	45	2,5	6,8	105125	Δ	▲	▲
L105.0200.4.7	2	4	6,4	3,7	7	25	40	2,5	6,8	105125	Δ	▲	▲
L105.0200.5.7	2	4	6,4	3,7	7	30	45	2,5	6,8	105125	Δ	▲	▲
P											●	●	●
M											●	●	●
K											○	●	●
N											-	●	●
S											-	●	●
H											-	-	-

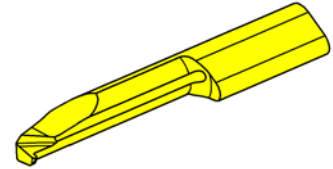
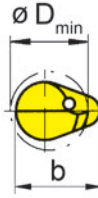
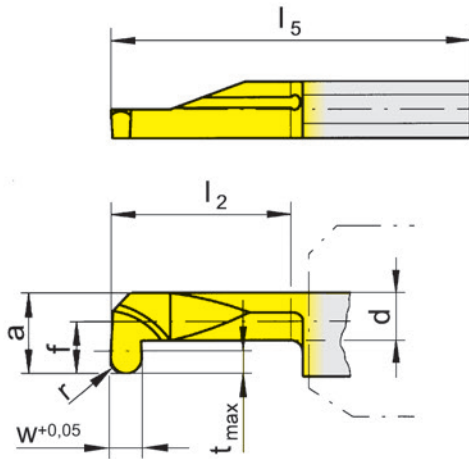
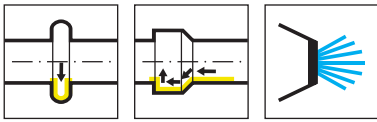

R = version à droite représentée  
R = versione destra come in figura

L = version à gauche  
L = versione sinistra a specchio

▲ en stock  
a stock

Nuance  
Leghe  
Δ 4 semaines  
4 settimane

Numéro de commande Codice prodotto	w	r	f	a	d	b	l <sub>2</sub>	l <sub>5</sub>	t <sub>max</sub>	D <sub>min</sub>	HIS	Nuance Leghe			
												EG35	ES15	TH35	TN35
R105.0025.2.3	0,5	0,25	1,4	2,7	1,9	5,9	15	30	0,6	3	105123	▲	▲		
R105.0005.1.4	1	0,5	1,9	3,7	2,7	6,4	10	25	0,8	4	105124	▲		▲	
R105.0005.2.4	1	0,5	1,9	3,7	2,7	6,4	15	30	0,8	4	105124	▲			▲
R105.0025.3.5	0,5	0,25	2,3	4,7	3,9	7	20	35	0,6	5	105125	▲	Δ		
R105.0005.3.5	1	0,5	2,3	4,7	3,5	7	20	35	1	5	105125	▲			▲
R105.0007.1.5	1,5	0,75	2,3	4,7	3,5	7	10	25	1	5	105125	Δ		▲	
R105.0007.3.5	1,5	0,75	2,3	4,7	3,5	7	20	35	1	5	105125	▲			▲
R105.0010.1.5	2	1	2,3	4,7	3,5	7	10	25	1	5	105125	▲		▲	
R105.0010.3.5	2	1	2,3	4,7	3,5	7	20	35	1	5	105125	▲			▲
L105.0005.1.4	1	0,5	1,9	3,7	2,7	6,4	10	25	0,8	4	105124	Δ		▲	
L105.0005.2.4	1	0,5	1,9	3,7	2,7	6,4	15	30	0,8	4	105124	▲			▲
L105.0005.3.5	1	0,5	2,3	4,7	3,5	7	20	35	1	5	105125	▲			▲
L105.0007.1.5	1,5	0,75	2,3	4,7	3,5	7	10	25	1	5	105125	Δ		Δ	
L105.0007.3.5	1,5	0,75	2,3	4,7	3,5	7	20	35	1	5	105125	Δ			▲
L105.0010.1.5	2	1	2,3	4,7	3,5	7	10	25	1	5	105125	Δ		Δ	
L105.0010.3.5	2	1	2,3	4,7	3,5	7	20	35	1	5	105125	Δ			▲
P	●	●	●	●	●	●	●	●	●	●	●	●	●	●	●
M	●	●	●	●	●	●	●	●	●	●	●	●	●	●	●
K	○	○	○	○	○	○	○	○	○	○	○	○	○	○	○
N	-	-	●	●	●	●	●	●	●	●	●	●	●	●	●
S	-	-	●	●	●	●	●	●	●	●	●	●	●	●	●
H	-	-	-	-	-	-	-	-	-	-	-	-	-	-	-

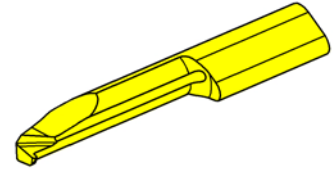
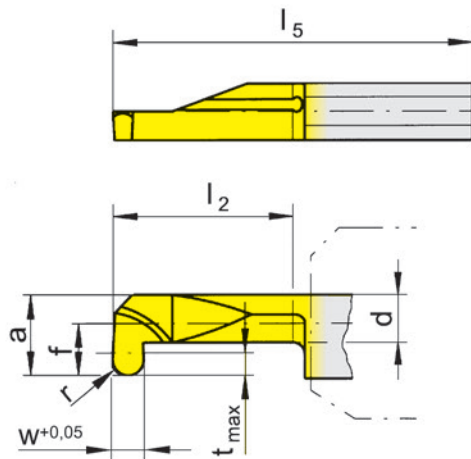
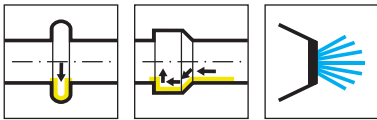

R = version à droite représentée  
R = versione destra come in figura

L = version à gauche  
L = versione sinistra a specchio

▲ en stock  
▲ a stock

Nuance  
Leghe  
Δ 4 semaines  
4 settimane

Numéro de commande Codice prodotto	w	r	f	a	d	b	l <sub>2</sub>	l <sub>5</sub>	t <sub>max</sub>	D <sub>min</sub>	HIS	Nuance Leghe		
												EG35	TH35	TN35
R105.0005.2.6	1	0,5	3,3	5,7	3,7	7	15	30	1,8	6	105125	▲	▲	
R105.0005.4.6	1	0,5	3,3	5,7	3,7	7	25	40	1,8	6	105125	▲		▲
R105.0007.2.6	1,5	0,75	3,3	5,7	3,7	7	15	30	1,8	6	105125	▲	▲	
R105.0007.4.6	1,5	0,75	3,3	5,7	3,7	7	25	40	1,8	6	105125	▲		▲
R105.0010.2.6	2	1	3,3	5,7	3,7	7	15	30	1,8	6	105125	▲	▲	
R105.0010.4.6	2	1	3,3	5,7	3,7	7	25	40	1,8	6	105125	▲		▲
L105.0005.2.6	1	0,5	3,3	5,7	3,7	7	15	30	1,8	6	105125	Δ	▲	
L105.0005.4.6	1	0,5	3,3	5,7	3,7	7	25	40	1,8	6	105125	Δ		▲
L105.0007.2.6	1,5	0,75	3,3	5,7	3,7	7	15	30	1,8	6	105125	Δ	Δ	
L105.0007.4.6	1,5	0,75	3,3	5,7	3,7	7	25	40	1,8	6	105125	Δ		▲
L105.0010.2.6	2	1	3,3	5,7	3,7	7	15	30	1,8	6	105125	Δ	Δ	
L105.0010.4.6	2	1	3,3	5,7	3,7	7	25	40	1,8	6	105125			▲
P	●	●	●											
M	●	●	●											
K	○	●	●											
N	-	●	●											
S	-	●	●											
H	-	-	-											

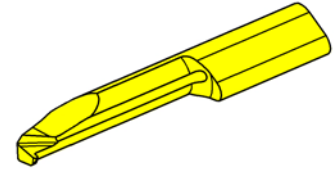
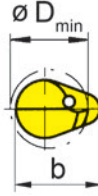
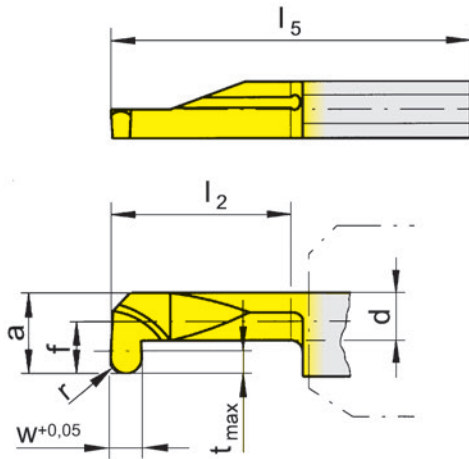
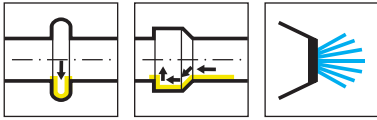

R = version à droite représentée  
R = versione destra come in figura

L = version à gauche  
L = versione sinistra a specchio

▲ en stock  
a stock

Nuance  
Leghe  
Δ 4 semaines  
4 settimane

Numéro de commande Codice prodotto	w	r	f	a	d	b	l <sub>2</sub>	l <sub>5</sub>	t <sub>max</sub>	D <sub>min</sub>	HIS	Nuance Leghe		
												EG35	TH35	TN35
R105.0005.3.7	1	0,5	4	6,4	3,7	7	20	35	2,5	6,8	105125	▲	▲	
R105.0005.5.7	1	0,5	4	6,4	3,7	7	30	45	2,5	6,8	105125	▲		▲
R105.0007.3.7	1,5	0,75	4	6,4	3,7	7	20	35	2,5	6,8	105125	Δ	▲	
R105.0007.5.7	1,5	0,75	4	6,4	3,7	7	30	45	2,5	6,8	105125	▲		▲
R105.0010.3.7	2	1	4	6,4	3,7	7	20	35	2,5	6,8	105125	▲	▲	
R105.0010.5.7	2	1	4	6,4	3,7	7	30	45	2,5	6,8	105125	▲		▲
L105.0005.3.7	1	0,5	4	6,4	3,7	7	20	35	2,5	6,8	105125	Δ	▲	
L105.0005.5.7	1	0,5	4	6,4	3,7	7	30	45	2,5	6,8	105125	Δ		▲
L105.0007.3.7	1,5	0,75	4	6,4	3,7	7	20	35	2,5	6,8	105125	Δ	▲	
L105.0007.5.7	1,5	0,75	4	6,4	3,7	7	30	45	2,5	6,8	105125	Δ		▲
L105.0010.3.7	2	1	4	6,4	3,7	7	20	35	2,5	6,8	105125	Δ	▲	
L105.0010.5.7	2	1	4	6,4	3,7	7	30	45	2,5	6,8	105125	Δ		▲
P	●	●	●											
M	●	●	●											
K	○	●	●											
N	-	●	●											
S	-	●	●											
H	-	-	-											

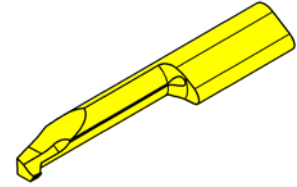
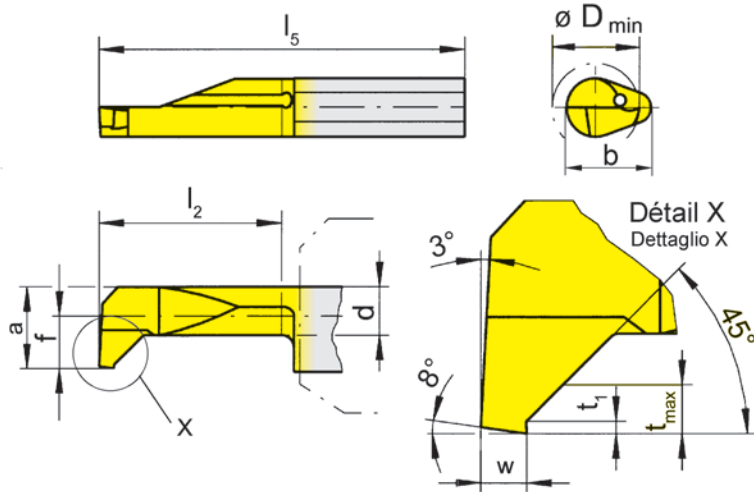
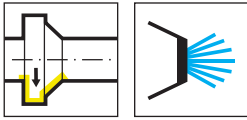

R = version à droite représentée  
R = versione destra come in figura

L = version à gauche  
L = versione sinistra a specchio

▲ en stock  
a stock

Nuance  
Leghe  
△ 4 semaines  
4 settimane

Numéro de commande Codice prodotto	w	f	a	d	b	l <sub>2</sub>	l <sub>5</sub>	t <sub>max</sub>	t <sub>1</sub>	D <sub>min</sub>	HIS			
												EG35	TI25	TN35
R105.0810.1.3	0,7	1,4	2,7	2	5,9	10	25	0,5	0,2	3	105123	▲		▲
R105.0810.2.3	0,7	1,4	2,7	2	5,9	15	30	0,5	0,2	3	105123	△		▲
R105.0810.1.4	1	1,9	3,7	2,7	6,4	10	25	0,7	0,2	4	105124	▲		▲
R105.0810.2.4	1	1,9	3,7	2,7	6,4	15	30	0,7	0,2	4	105124	▲		▲
R105.0810.3.4	1	1,9	3,7	2,7	6,4	20	35	0,7	0,2	4	105124	△		▲
R105.0810.3.5	1	2,3	4,7	3,5	7	20	35	0,7	0,2	5	105125	▲	▲	▲
R105.0810.4.5	1	2,3	4,7	3,5	7	25	40	0,7	0,2	5	105125	▲	▲	▲
R105.0810.5.5	1	2,3	4,7	3,5	7	30	45	0,7	0,2	5	105125	▲	▲	▲
R105.0810.5.6	1	3,1	5,5	4,2	7	30	45	1	0,2	6	105125	▲		▲
R105.0810.7.6	1	3,1	5,5	4,2	7	40	55	1	0,2	6	105125	△		▲
L105.0810.1.3	0,7	1,4	2,7	2	5,9	10	25	0,5	0,2	3	105123	△		▲
L105.0810.2.3	0,7	1,4	2,7	2	5,9	15	30	0,5	0,2	3	105123	△		▲
L105.0810.1.4	1	1,9	3,7	2,7	6,4	10	25	0,7	0,2	4	105124	△		△
L105.0810.2.4	1	1,9	3,7	2,7	6,4	15	30	0,7	0,2	4	105124	△		▲
L105.0810.3.4	1	1,9	3,7	2,7	6,4	20	35	0,7	0,2	4	105124	△		▲
L105.0810.3.5	1	2,3	4,7	3,5	7	20	35	0,7	0,2	5	105125	△	▲	▲
L105.0810.4.5	1	2,3	4,7	3,5	7	25	40	0,7	0,2	5	105125	△	▲	▲
L105.0810.5.5	1	2,3	4,7	3,5	7	30	45	0,7	0,2	5	105125	△	▲	△
L105.0810.5.6	1	3,1	5,5	4,2	7	30	45	1	0,2	6	105125	△		▲
L105.0810.7.6	1	3,1	5,5	4,2	7	40	55	1	0,2	6	105125	△		△
P	●	●	●											
M	●	●	●											
K	○	●	●											
N	-	●	●											
S	-	●	●											
H	-	-	-											

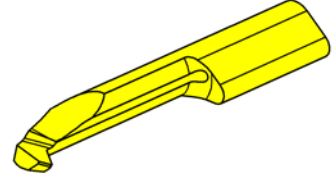
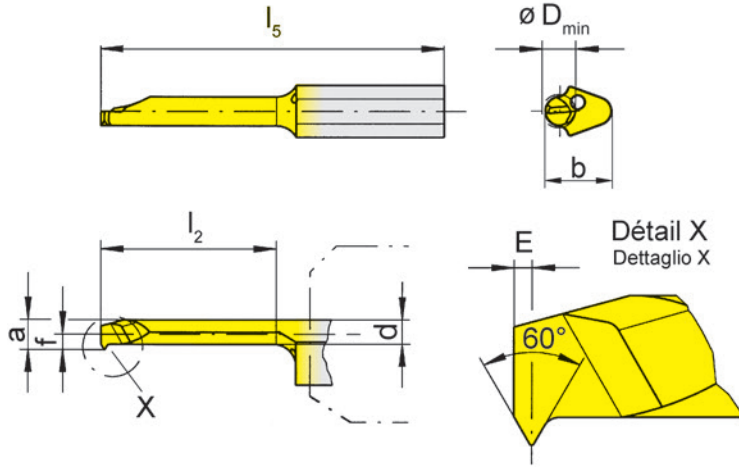
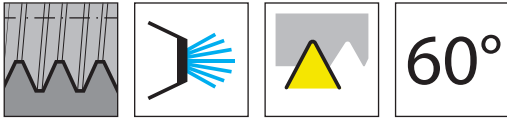

R = version à droite représentée  
R = versione destra come in figura

L = version à gauche  
L = versione sinistra a specchio

Nuance  
Leghe  
▲ en stock  
a stock  
Δ 4 semaines  
4 settimane

Numéro de commande Codice prodotto	P	E	f	a	d	b	l <sub>2</sub>	l <sub>5</sub>	D <sub>min</sub>	HIS	Nuance	
											EG35	TN35
R105.0102.2.3	0,25	0,3	1,4	2,7	2,2	5,9	15	30	3	105123	Δ	▲
L105.0102.2.3	0,25	0,3	1,4	2,7	2,2	5,9	15	30	3	105123	Δ	▲
	P	●	●									
	M	●	●									
	K	○	●									
	N	-	●									
	S	-	●									
	H	-	-									

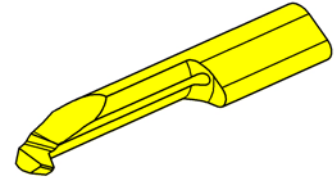
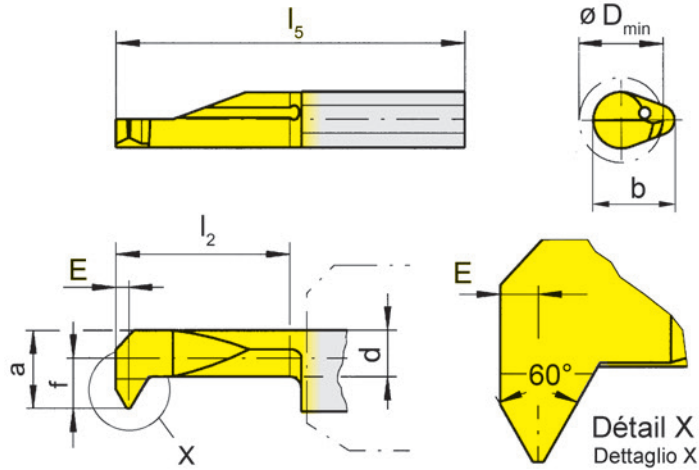
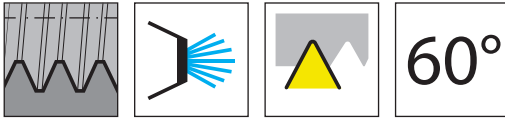

R = version à droite représentée  
R = versione destra come in figura

L = version à gauche  
L = versione sinistra a specchio

▲ en stock  
a stock

Nuance  
Leghe  
Δ 4 semaines  
4 settimane

Numéro de commande Codice prodotto	P	E	f	a	d	b	l <sub>2</sub>	l <sub>5</sub>	D <sub>min</sub>	HIS	Nuance Leghe		
											EG35	TN35	
R105.0203.1.3	0,35	0,3	1,4	2,7	2,1	5,9	10	25	3	105123	▲	▲	
R105.0203.2.5	0,35	0,3	2,3	4,7	3,5	7	15	30	5	105125	▲	▲	
L105.0203.1.3	0,35	0,3	1,4	2,7	2,1	5,9	10	25	3	105123	Δ	Δ	
L105.0203.2.5	0,35	0,3	2,3	4,7	3,5	7	15	30	5	105125		▲	
											P	●	●
											M	●	●
											K	○	●
											N	-	●
											S	-	●
											H	-	-

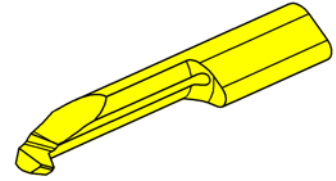
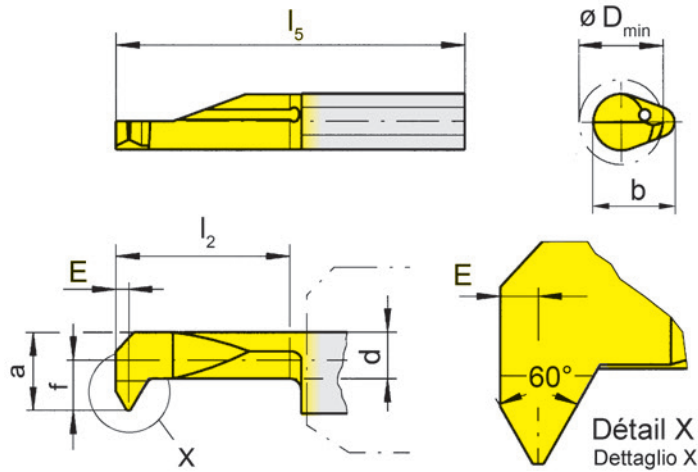
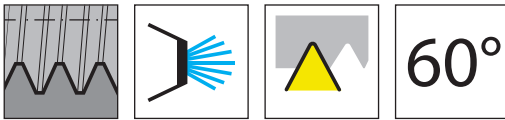

R = version à droite représentée  
R = versione destra come in figura

L = version à gauche  
L = versione sinistra a specchio

▲ en stock  
a stock

Nuance  
Leghe  
Δ 4 semaines  
4 settimane

Numéro de commande Codice prodotto	P	E	f	a	d	b	l <sub>2</sub>	l <sub>5</sub>	D <sub>min</sub>	HIS	Nuance Leghe		
											EG35	TH35	TN35
R105.0205.2.3	0,5	0,35	1,4	2,7	2,1	5,9	15	30	3	105123	▲		▲
R105.0205.2.4	0,5	0,35	1,9	3,7	2,7	6,4	15	30	4	105124	▲	▲	▲
R105.0205.3.4	0,5	0,35	1,9	3,7	2,7	6,4	20	35	4	105124	▲		▲
R105.0205.2.5	0,5	0,35	2,3	4,7	3,5	7	15	30	5	105125	▲	▲	▲
R105.0205.3.5	0,5	0,35	2,3	4,7	3,5	7	20	35	5	105125	Δ		▲
R105.0205.4.5	0,5	0,35	2,3	4,7	3,5	7	25	40	5	105125			▲
R105.0205.3.6	0,5	0,35	3,3	5,7	4,8	7	20	35	6	105125	▲		▲
L105.0205.2.3	0,5	0,35	1,4	2,7	2,1	5,9	15	30	3	105123	Δ		▲
L105.0205.2.4	0,5	0,35	1,9	3,7	2,7	6,4	15	30	4	105124	Δ	Δ	▲
L105.0205.3.4	0,5	0,35	1,9	3,7	2,7	6,4	20	35	4	105124	Δ		Δ
L105.0205.2.5	0,5	0,35	2,3	4,7	3,5	7	15	30	5	105125	Δ	Δ	▲
L105.0205.3.5	0,5	0,35	2,3	4,7	3,5	7	20	35	5	105125	Δ		Δ
L105.0205.4.5	0,5	0,35	2,3	4,7	3,5	7	25	40	5	105125	Δ		Δ
L105.0205.3.6	0,5	0,35	3,3	5,7	4,8	7	20	35	6	105125	Δ		Δ
P	●	●	●										
M	●	●	●										
K	○	●	●										
N	-	●	●										
S	-	●	●										
H	-	-	-										

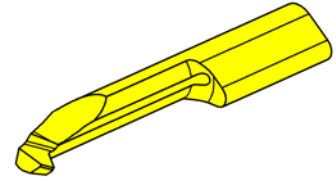
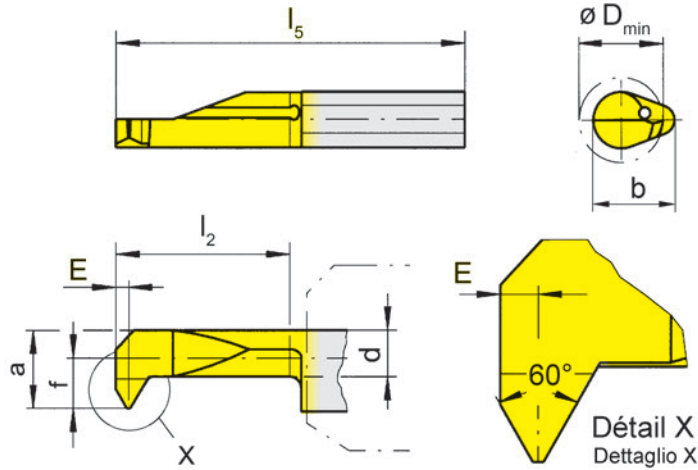
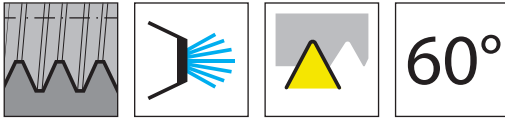

R = version à droite représentée  
R = versione destra come in figura

L = version à gauche  
L = versione sinistra a specchio

▲ en stock  
a stock

Nuance  
Leghe  
Δ 4 semaines  
4 settimane

Numéro de commande Codice prodotto	P	P <sub>max</sub>	E	f	a	d	b	l <sub>2</sub>	l <sub>5</sub>	D <sub>min</sub>	HIS	Nuance Leghe		
												EG35	TH35	TN35
R105.0407.2.3	0,5	0,75	0,45	1,4	2,7	2	5,9	15	30	3	105123	▲		▲
R105.0407.1.4	0,5	0,75	0,45	1,9	3,7	2,7	6,4	10	25	4	105124	▲		▲
R105.0407.2.4	0,5	0,75	0,45	1,9	3,7	2,7	6,4	15	30	4	105124	▲		▲
R105.0407.3.4	0,5	0,75	0,45	1,9	3,7	2,7	6,4	20	35	4	105124	▲		▲
R105.0407.2.5	0,5	0,75	0,45	2,3	4,7	3,5	7	15	30	5	105125	▲	▲	▲
R105.0407.3.5	0,5	0,75	0,45	2,3	4,7	3,5	7	20	35	5	105125	Δ		▲
R105.0407.4.5	0,5	0,75	0,45	2,3	4,7	3,5	7	25	40	5	105125	▲		▲
R105.0407.3.6	0,5	0,75	0,45	3,3	5,7	4,7	7	20	35	6	105125	▲		▲
L105.0407.2.3	0,5	0,75	0,45	1,4	2,7	2	5,9	15	30	3	105123	Δ		Δ
L105.0407.1.4	0,5	0,75	0,45	1,9	3,7	2,7	6,4	10	25	4	105124	Δ		▲
L105.0407.2.4	0,5	0,75	0,45	1,9	3,7	2,7	6,4	15	30	4	105124	Δ		▲
L105.0407.3.4	0,5	0,75	0,45	1,9	3,7	2,7	6,4	20	35	4	105124	Δ		Δ
L105.0407.2.5	0,5	0,75	0,45	2,3	4,7	3,5	7	15	30	5	105125	▲	▲	▲
L105.0407.3.5	0,5	0,75	0,45	2,3	4,7	3,5	7	20	35	5	105125	Δ		Δ
L105.0407.4.5	0,5	0,75	0,45	2,3	4,7	3,5	7	25	40	5	105125	Δ		Δ
L105.0407.3.6	0,5	0,75	0,45	3,3	5,7	4,7	7	20	35	6	105125	Δ		Δ
P	●	●	●											
M	●	●	●											
K	○	●	●											
N	-	●	●											
S	-	●	●											
H	-	-	-											

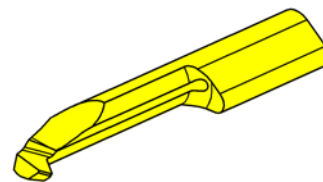
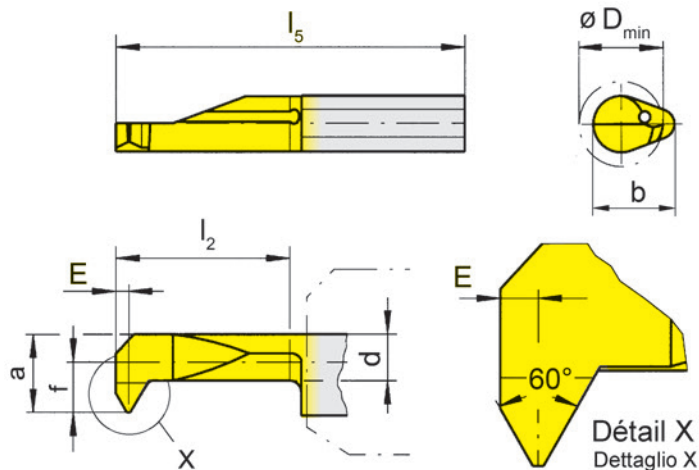

R = version à droite représentée  
R = versione destra come in figura

L = version à gauche  
L = versione sinistra a specchio

▲ en stock  
a stock

Nuance  
Leghe  
△ 4 semaines  
4 settimane

Numéro de commande Codice prodotto	P	P <sub>max</sub>	E	f	a	d	b	l <sub>2</sub>	l <sub>5</sub>	D <sub>min</sub>	HIS			
												EG35	TH35	TN35
R105.0510.2.5	1	1	0,55	2,1	4,5	3,5	7	15	30	4,8	105125	▲	▲	▲
R105.0510.3.5	1	1	0,55	2,1	4,5	3,5	7	20	35	4,8	105125	▲		▲
R105.0510.4.5	1	1	0,55	2,1	4,5	3,5	7	25	40	4,8	105125	▲		▲
R105.0510.2.6	1	1	0,55	3,3	5,7	3,7	7	15	30	6	105125	▲	▲	▲
R105.0612.2.6	1,25	1,25	0,65	3,3	5,7	3,7	7	15	30	6	105125	▲	▲	▲
R105.0612.3.6	1,25	1,25	0,65	3,3	5,7	3,7	7	20	35	6	105125	▲		▲
R105.0612.4.6	1,25	1,25	0,65	3,3	5,7	3,7	7	25	40	6	105125	▲		▲
R105.0815.2.7	1,5	1,5	0,75	4	6,4	3,7	7	15	30	7	105125	▲	▲	▲
R105.0815.3.7	1,5	1,5	0,75	4	6,4	3,7	7	20	35	7	105125	▲		▲
R105.0815.4.7	1,5	1,5	0,75	4	6,4	3,7	7	25	40	7	105125	▲		▲
L105.0510.2.5	1	1	0,55	2,1	4,5	3,5	7	15	30	4,8	105125	▲	▲	▲
L105.0510.3.5	1	1	0,55	2,1	4,5	3,5	7	20	35	4,8	105125	△		▲
L105.0510.4.5	1	1	0,55	2,1	4,5	3,5	7	25	40	4,8	105125	△		▲
L105.0510.2.6	1	1	0,55	3,3	5,7	3,7	7	15	30	6	105125	▲	▲	▲
L105.0612.2.6	1,25	1,25	0,65	3,3	5,7	3,7	7	15	30	6	105125	▲	▲	▲
L105.0612.3.6	1,25	1,25	0,65	3,3	5,7	3,7	7	20	35	6	105125	△		▲
L105.0612.4.6	1,25	1,25	0,65	3,3	5,7	3,7	7	25	40	6	105125	△		▲
L105.0815.2.7	1,5	1,5	0,75	4	6,4	3,7	7	15	30	7	105125		▲	▲
L105.0815.3.7	1,5	1,5	0,75	4	6,4	3,7	7	20	35	7	105125	△		▲
L105.0815.4.7	1,5	1,5	0,75	4	6,4	3,7	7	25	40	7	105125	△		▲
P	●	●	●											
M	●	●	●											
K	○	●	●											
N	-	●	●											
S	-	●	●											
H	-	-	-											

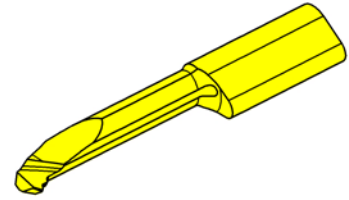
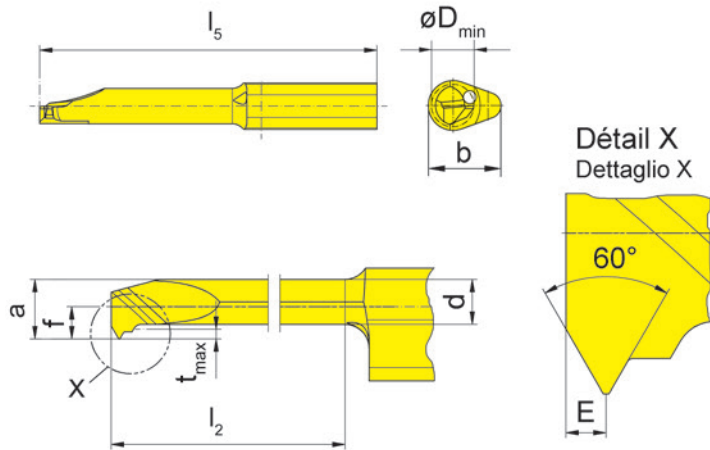
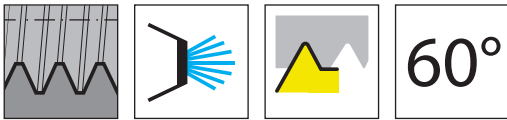

R = version à droite représentée  
R = versione destra come in figura

L = version à gauche  
L = versione sinistra a specchio

▲ en stock  
a stock

Nuance  
Leghe  
△ 4 semaines  
4 settimane

Número de commande Codice prodotto	P	E	f	a	d	b	$l_2$	$l_5$	$D_{min}$	HIS	EG35	TH35
R105.VPM3.2.3	0,5	0,3	1,4	2,2	1,65	5,9	9	25	2,4	105123	▲	▲
R105.VPM3.4.3	0,5	0,3	1,4	2,2	1,65	5,9	16	35	2,4	105123	▲	▲
R105.VPM4.2.4	0,7	0,4	1,5	2,9	2,1	6,4	15	30	3,2	105124	▲	▲
R105.VPM4.3.4	0,7	0,4	1,5	2,9	2,1	6,4	20	35	3,2	105124	▲	▲
R105.VPM5.2.5	0,8	0,5	2	3,7	2,8	7	15	30	4,1	105125	▲	▲
R105.VPM5.4.5	0,8	0,5	2	3,7	2,8	7	25	40	4,1	105125	▲	▲
R105.VPM6.3.6	1	0,5	2,4	4,5	3,4	7	20	35	4,9	105125	▲	▲
R105.VPM6.4.6	1	0,5	2,4	4,5	3,4	7	25	40	4,9	105125	▲	▲
R105.VPM6.5.6	1	0,5	2,4	4,5	3,4	7	30	45	4,9	105125	▲	▲
R105.VPM8.3.8	1,25	0,7	3,8	6,2	4,7	7	20	35	6,6	105125	▲	▲
R105.VPM8.5.8	1,25	0,7	3,8	6,2	4,7	7	30	45	6,6	105125	▲	▲
L105.VPM3.2.3	0,5	0,3	1,4	2,2	1,65	5,9	9	25	2,4	105123	△	▲
L105.VPM3.4.3	0,5	0,3	1,4	2,2	1,65	5,9	16	35	2,4	105123	△	△
L105.VPM4.2.4	0,7	0,4	1,5	2,9	2,1	6,4	15	30	3,2	105124	△	△
L105.VPM4.3.4	0,7	0,4	1,5	2,9	2,1	6,4	20	35	3,2	105124	△	△
L105.VPM5.2.5	0,8	0,5	2	3,7	2,8	7	15	30	4,1	105125	△	▲
L105.VPM5.4.5	0,8	0,5	2	3,7	2,8	7	25	40	4,1	105125	△	▲
L105.VPM6.3.6	1	0,5	2,4	4,5	3,4	7	20	35	4,9	105125	▲	▲
L105.VPM6.4.6	1	0,5	2,4	4,5	3,4	7	25	40	4,9	105125	△	△
L105.VPM6.5.6	1	0,5	2,4	4,5	3,4	7	30	45	4,9	105125	△	▲
L105.VPM8.3.8	1,25	0,7	3,8	6,2	4,7	7	20	35	6,6	105125	△	▲
L105.VPM8.5.8	1,25	0,7	3,8	6,2	4,7	7	30	45	6,6	105125	△	▲

P	●	●
M	●	●
K	○	●
N	-	●
S	-	●
H	-	-

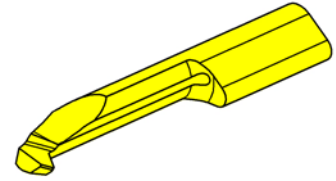
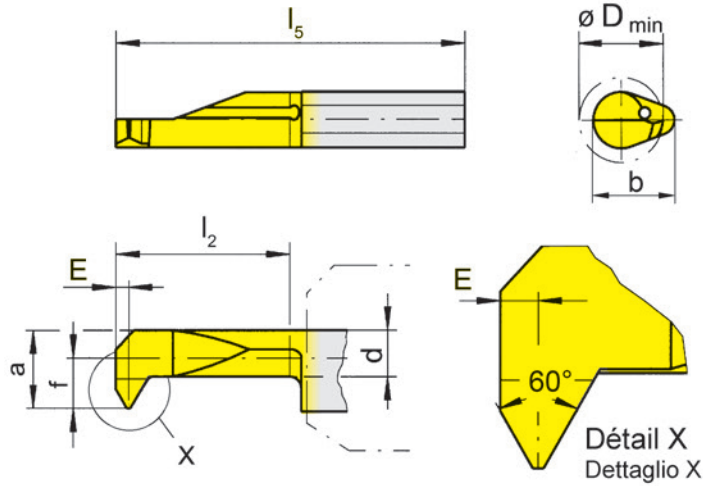
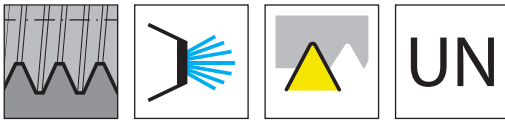

R = version à droite représentée  
R = versione destra come in figura

L = version à gauche  
L = versione sinistra a specchio

▲ en stock  
a stock

Nuance  
Leghe  
△ 4 semaines  
4 settimane

Numéro de commande Codice prodotto	TPI <sub>min</sub>	TPI <sub>max</sub>	E	f	a	d	b	l <sub>2</sub>	l <sub>5</sub>	D <sub>min</sub>	HIS	Nuance Leghe		
												EG35	TH35	TN35
R105.3240.2.4	32	40	0,45	1,9	3,7	2,7	6,4	15	30	4	105124	▲		▲
R105.1620.2.5	16	20	0,7	2,3	4,7	3,3	7	15	30	5	105125	▲	▲	
R105.1620.3.5	16	20	0,7	2,3	4,7	3,3	7	20	35	5	105125	△	▲	
R105.2428.2.5	24	28	0,55	2,3	4,7	3,5	7	15	30	5	105125	▲	△	▲
R105.3240.2.5	32	40	0,45	2,3	4,7	3,5	7	15	30	5	105125	▲		▲
R105.1620.2.6	16	20	0,7	3,3	5,7	3,7	7	15	30	6	105125	▲	△	▲
R105.1620.3.6	16	20	0,7	3,3	5,7	3,7	7	20	35	6	105125	▲		▲
R105.1620.4.6	16	20	0,7	3,3	5,7	3,7	7	25	40	6	105125	▲		▲
R105.2428.2.6	24	28	0,55	3,3	5,7	3,7	7	15	30	6	105125	▲		▲
R105.2428.3.6	24	28	0,55	3,3	5,7	3,7	7	20	35	6	105125	▲		▲
R105.2428.4.6	24	28	0,55	3,3	5,7	3,7	7	25	40	6	105125	▲		▲
L105.3240.2.4	32	40	0,45	1,9	3,7	2,7	6,4	15	30	4	105124	△		▲
L105.1620.2.5	16	20	0,7	2,3	4,7	3,3	7	15	30	5	105125	△	▲	
L105.1620.3.5	16	20	0,7	2,3	4,7	3,3	7	20	35	5	105125	△	△	
L105.2428.2.5	24	28	0,55	2,3	4,7	3,5	7	15	30	5	105125	△		▲
L105.3240.2.5	32	40	0,45	2,3	4,7	3,5	7	15	30	5	105125	△		▲
L105.1620.2.6	16	20	0,7	3,3	5,7	3,7	7	15	30	6	105125	△		▲
L105.1620.3.6	16	20	0,7	3,3	5,7	3,7	7	20	35	6	105125	△		△
L105.1620.4.6	16	20	0,7	3,3	5,7	3,7	7	25	40	6	105125	△		△
L105.2428.2.6	24	28	0,55	3,3	5,7	3,7	7	15	30	6	105125	▲		▲
L105.2428.3.6	24	28	0,55	3,3	5,7	3,7	7	20	35	6	105125	△		△
L105.2428.4.6	24	28	0,55	3,3	5,7	3,7	7	25	40	6	105125	△		▲
P	●	●	●											
M	●	●	●											
K	○	●	●											
N	-	●	●											
S	-	●	●											
H	-	-	-											

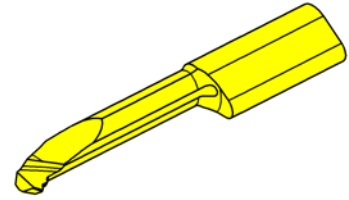
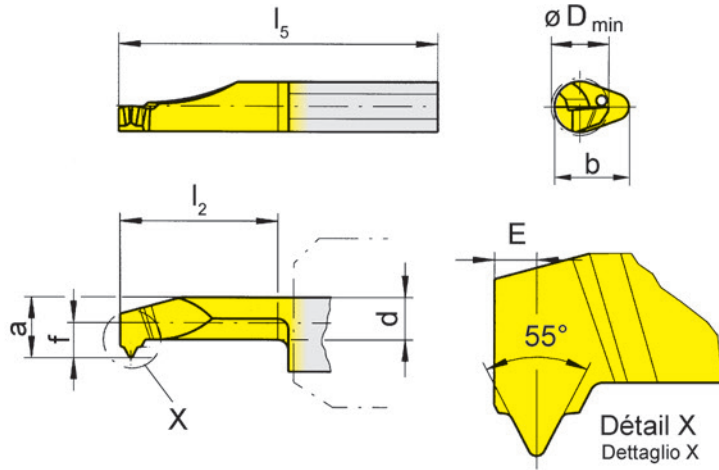
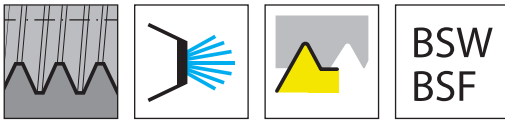

R = version à droite représentée  
R = versione destra come in figura

L = version à gauche  
L = versione sinistra a specchio

▲ en stock  
a stock

Nuance  
Leghe  
Δ 4 semaines  
4 settimane

Numéro de commande Codice prodotto	TPI	E	f	a	d	b	l <sub>2</sub>	l <sub>5</sub>	D <sub>min</sub>	HIS	Nuance		
											EG35	TN35	
R105.5520.2.4	20	1	1,9	3,7	2,5	6,4	15	30	4	105124	▲	▲	
R105.5524.2.5	24	0,8	2,3	4,7	3,5	7	15	30	5	105125	Δ	Δ	
R105.5526.2.5	26	0,8	2,3	4,7	3,5	7	15	30	5	105125		▲	
R105.5528.2.5	28	0,8	2,3	4,7	3,5	7	15	30	5	105125	▲	▲	
L105.5524.2.5	24	0,8	2,3	4,7	3,5	7	15	30	5	105125	Δ	Δ	
L105.5526.2.5	26	0,8	2,3	4,7	3,5	7	15	30	5	105125	Δ	Δ	
L105.5528.2.5	28	0,8	2,3	4,7	3,5	7	15	30	5	105125	Δ	Δ	
											P	●	●
											M	●	●
											K	○	●
											N	-	●
											S	-	●
											H	-	-

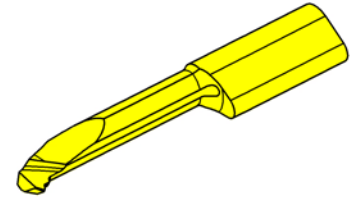
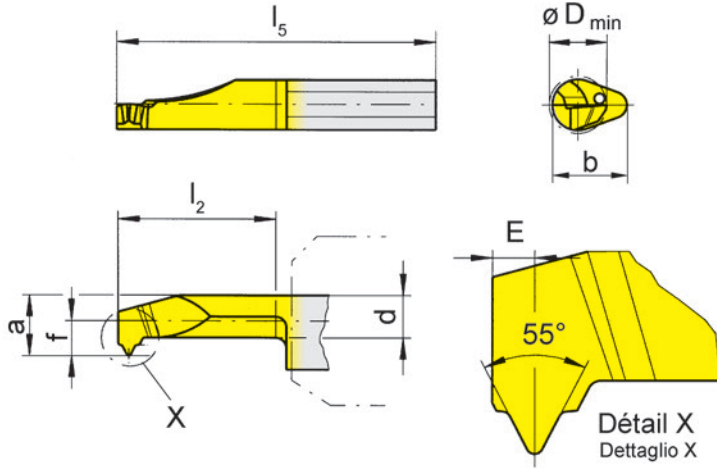
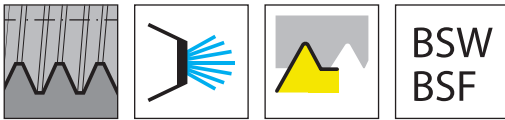

R = version à droite représentée  
R = versione destra come in figura

L = version à gauche  
L = versione sinistra a specchio

▲ en stock  
a stock

Nuance  
Leghe  
Δ 4 semaines  
4 settimane

Numéro de commande Codice prodotto	TPI	E	f	a	d	b	l <sub>2</sub>	l <sub>5</sub>	D <sub>min</sub>	HIS	Material		
											EG35	TN35	
R105.5524.2.6	24	0,8	3,3	5,7	3,7	7	15	30	6	105125	Δ	Δ	
R105.5526.2.6	26	0,8	3,3	5,7	3,7	7	15	30	6	105125	Δ	▲	
R105.5528.2.6	28	0,8	3,3	5,7	3,7	7	15	30	6	105125	▲	▲	
R105.5519.2.6	19	1	3,3	5,7	3,7	7	15	30	6	105125	▲	▲	
R105.5520.2.6	20	1	3,3	5,7	3,7	7	15	30	6	105125	Δ	▲	
R105.5522.2.6	22	1	3,3	5,7	3,7	7	15	30	6	105125	Δ	Δ	
R105.5524.3.6	24	0,8	3,3	5,7	3,7	7	20	35	6	105125	▲	Δ	
R105.5526.3.6	26	0,8	3,3	5,7	3,7	7	20	35	6	105125	Δ	Δ	
R105.5528.3.6	28	0,8	3,3	5,7	3,7	7	20	35	6	105125	▲	▲	
R105.5519.3.6	19	1	3,3	5,7	3,7	7	20	35	6	105125	▲	▲	
R105.5522.3.6	22	1	3,3	5,7	3,7	7	20	35	6	105125	Δ	Δ	
L105.5524.2.6	24	0,8	3,3	5,7	3,7	7	15	30	6	105125	Δ	Δ	
L105.5526.2.6	26	0,8	3,3	5,7	3,7	7	15	30	6	105125	Δ	Δ	
L105.5528.2.6	28	0,8	3,3	5,7	3,7	7	15	30	6	105125	Δ	Δ	
L105.5519.2.6	19	1	3,3	5,7	3,7	7	15	30	6	105125	Δ	▲	
L105.5520.2.6	20	1	3,3	5,7	3,7	7	15	30	6	105125	Δ	Δ	
L105.5522.2.6	22	1	3,3	5,7	3,7	7	15	30	6	105125	Δ	Δ	
L105.5528.3.6	28	0,8	3,3	5,7	3,7	7	20	35	6	105125	Δ	Δ	
											P	●	●
											M	●	●
											K	○	●
											N	-	●
											S	-	●
											H	-	-

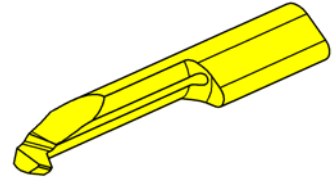
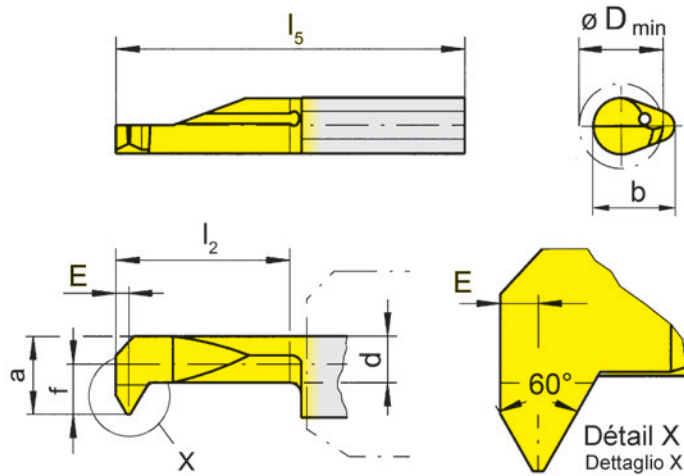
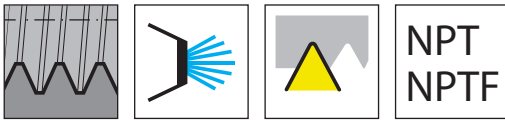

R = version à droite représentée  
R = versione destra come in figura

L = version à gauche  
L = versione sinistra a specchio

▲ en stock  
▲ a stock

Nuance  
Leghe  
Δ 4 semaines  
4 settimane

Numéro de commande Codice prodotto	TPI	E	f	a	d	b	l <sub>2</sub>	l <sub>5</sub>	D <sub>min</sub>	HIS	Nuance Leghe			
											EG35	TH35	TN35	
R105.NP18.2.6	18	1	3,3	5,7	3,7	7	15	30	6	105125	▲		▲	
R105.NP18.3.6	18	1	3,3	5,7	3,7	7	20	35	6	105125	Δ	▲	▲	
R105.NP18.4.6	18	1	3,3	5,7	3,7	7	25	40	6	105125	Δ	Δ	▲	
R105.NP27.2.6	27	0,8	3,3	5,7	3,7	7	15	30	6	105125	▲		▲	
R105.NP27.3.6	27	0,8	3,3	5,7	3,7	7	20	35	6	105125	Δ	Δ	Δ	
R105.NP27.4.6	27	0,8	3,3	5,7	3,7	7	25	40	6	105125	Δ	Δ	Δ	
L105.NP18.2.6	18	1	3,3	5,7	3,7	7	15	30	6	105125	Δ		▲	
L105.NP18.3.6	18	1	3,3	5,7	3,7	7	20	35	6	105125	Δ	Δ	Δ	
L105.NP18.4.6	18	1	3,3	5,7	3,7	7	25	40	6	105125	Δ	Δ	Δ	
L105.NP27.2.6	27	0,8	3,3	5,7	3,7	7	15	30	6	105125	Δ		▲	
L105.NP27.3.6	27	0,8	3,3	5,7	3,7	7	20	35	6	105125	Δ	Δ		
L105.NP27.4.6	27	0,8	3,3	5,7	3,7	7	25	40	6	105125	Δ	Δ	Δ	
											P	●	●	●
											M	●	●	●
											K	○	●	●
											N	-	●	●
											S	-	●	●
											H	-	-	-

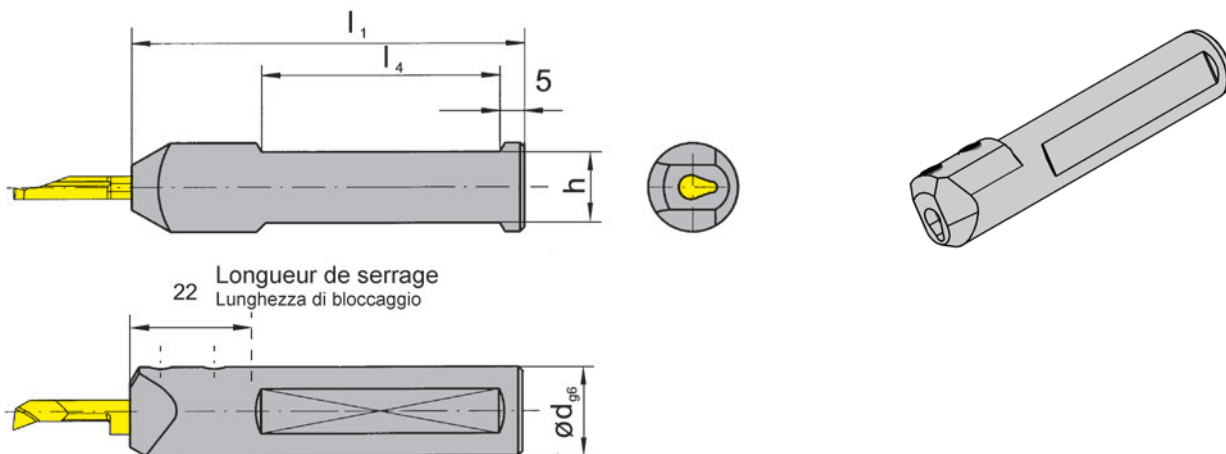
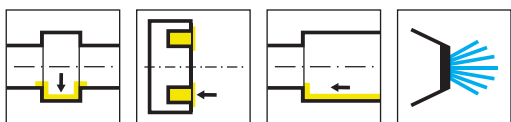

Illustration de coupe à droite représentée  
Figura = taglio destro

Numéro de commande Codice prodotto	d	l <sub>1</sub>	h	l <sub>4</sub>	HWS
B105.0012.02	12	85	11	50	105225
B105.0016.02	16	85	14	50	105225
B105.0020.02	20	100	18	55	105225
B105.0022.02	22	100	20	55	105225

### Pièces Détachées

Ricambi

Porte outils Portainsero	Vis de serrage Vite di serraggio	Tournevis TORX PLUS® Cacciavite TORX PLUS®
B105...	6.075T15P	T15PQ

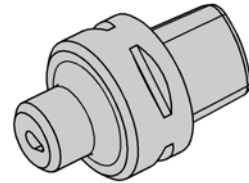
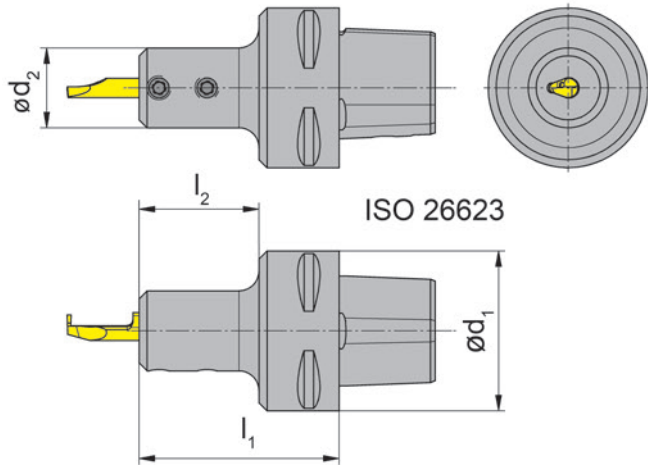
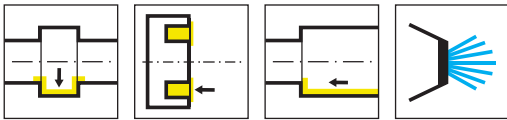

L = version à gauche représentée  
L = versione sinistra come in figura

R = version à droite  
R = versione destra a specchio

Numéro de commande Codice prodotto	$d_1$	$d_2$	$l_1$	$l_2$	HWS
<b>RB105.00C4.20.1.02</b>	40	20	50	20	105225
<b>RB105.00C6.20.1.02</b>	63	20	52	30	105225
<b>LB105.00C4.20.1.02</b>	40	20	50	20	105225
<b>LB105.00C6.20.1.02</b>	63	20	52	30	105225

Seulement pour les plaquettes avec une longueur de serrage prolongée  
solo per inserti con area di serraggio a due viti

### Pièces Détachées

Ricambi

Porte outils Portainsero	Vis de serrage Vite di serraggio	Tournevis TORX PLUS® Cacciavite TORX PLUS®
R/LB105...	<b>6.075T15P</b>	<b>T15PQ</b>

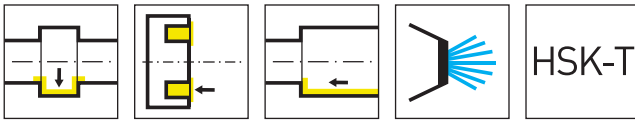

HSK-T

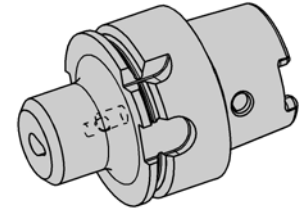
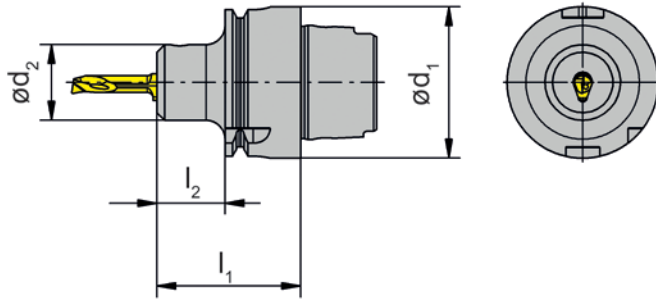

R = version à droite représentée  
R = versione destra come in figura

L = version à gauche  
L = versione sinistra a specchio

Numéro de commande Codice prodotto	$d_1$	$l_1$	$l_2$	$d_2$	HWS
HSKT40.LB105.20.1.02	40	48	28	20	105223 • 105224 • 105225
HSKT40.RB105.20.1.02	40	48	28	20	105223 • 105224 • 105225

### Pièces Détachées

Ricambi

Plaquette de coupe Inserto	Vis de serrage Vite di serraggio	Tournevis TORX PLUS® Cacciavite TORX PLUS®
HSKT40...	6.075T15P	T15PQ

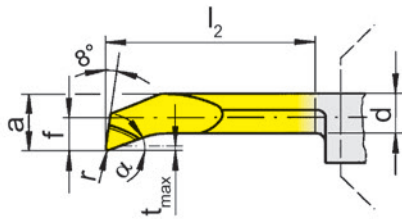
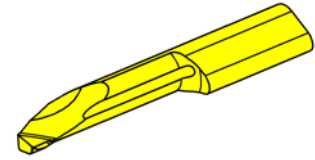
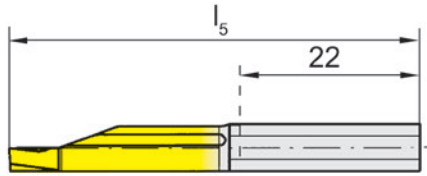
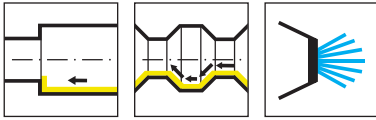

R = version à droite représentée  
R = versione destra come in figura

L = version à gauche  
L = versione sinistra a specchio

▲ en stock  
a stock

Nuance  
Leghe  
Δ 4 semaines  
4 settimane

Numéro de commande Codice prodotto	r	f	a	d	b	l <sub>2</sub>	l <sub>5</sub>	t <sub>max</sub>	D <sub>min</sub>	α	HIS	Nuance Leghe			
												EG35	TH35	TI25	
R105.1823.4.5.2	0,1	2,3	4,7	4,2	7	25	50	0,3	5	21°	105225	Δ	▲	▲	
R105.1823.5.5.2	0,1	2,3	4,7	4,2	7	30	55	0,3	5	21°	105225	Δ	▲	▲	
R105.1833.4.6.2	0,1	3,3	5,7	4,9	7	25	50	0,3	6	21°	105225	Δ	▲	▲	
R105.1833.5.6.2	0,1	3,3	5,7	4,9	7	30	55	0,3	6	21°	105225	Δ	▲	▲	
R105.1840.4.7.2	0,1	4	6,4	5,4	7	25	50	0,3	6,8	21°	105225	Δ	▲	▲	
R105.1840.5.7.2	0,1	4	6,4	5,4	7	30	55	0,3	6,8	21°	105225	Δ	▲	▲	
R105.1840.7.7.2	0,1	4	6,4	5,4	7	40	65	0,3	6,8	21°	105225	▲		▲	
R105.4733.5.6.2	0,1	3,3	5,7	3,7	7	30	55	1,8	6	47°	105225	Δ	▲	▲	
L105.1823.4.5.2	0,1	2,3	4,7	4,2	7	25	50	0,3	5	21°	105225	Δ	▲	▲	
L105.1823.5.5.2	0,1	2,3	4,7	4,2	7	30	55	0,3	5	21°	105225		▲	Δ	
L105.1833.4.6.2	0,1	3,3	5,7	4,9	7	25	50	0,3	6	21°	105225	Δ	Δ	Δ	
L105.1833.5.6.2	0,1	3,3	5,7	4,9	7	30	55	0,3	6	21°	105225	Δ	▲	Δ	
L105.1840.4.7.2	0,1	4	6,4	5,4	7	25	50	0,3	6,8	21°	105225	Δ	▲	▲	
L105.1840.5.7.2	0,1	4	6,4	5,4	7	30	55	0,3	6,8	21°	105225	Δ	Δ	▲	
L105.1840.7.7.2	0,1	4	6,4	5,4	7	40	65	0,3	6,8	21°	105225	Δ		Δ	
L105.4733.5.6.2	0,1	3,3	5,7	3,7	7	30	55	1,8	6	47°	105225	Δ	Δ	Δ	
avec serrage plus long con lunghezza di bloccaggio maggiorata												P	●	●	●
												M	●	●	●
												K	○	●	●
												N	-	●	●
												S	-	●	●
												H	-	-	-

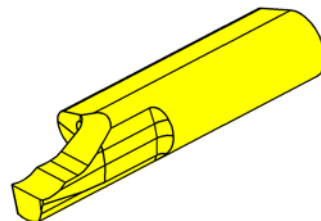
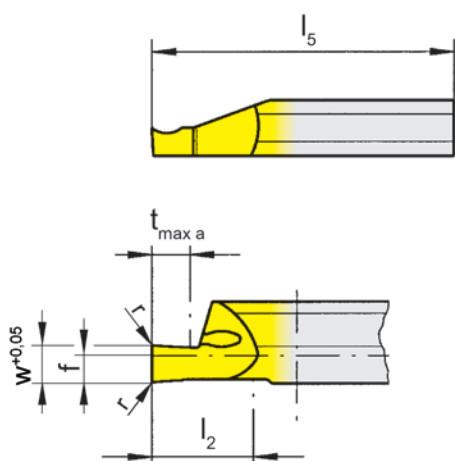
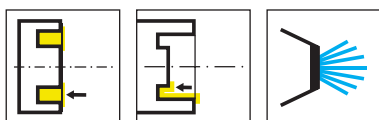

R = version à droite représentée  
R = versione destra come in figura

L = version à gauche  
L = versione sinistra a specchio

▲ en stock  
a stock

Nuance  
Leghe  
Δ 4 semaines  
4 settimane

Numéro de commande Codice prodotto	w	r	f	b	l <sub>2</sub>	l <sub>5</sub>	t <sub>max a</sub>	D <sub>a min</sub>	HIS	Nuance Leghe		
										EG35	ES15	TI25
R105.0505.1.8	0,5	-	2	7	10	25	2	5	105125	▲	▲	
R105.0510.1.8	1	0,05	2	7	10	25	2	5	105125	▲		▲
R105.0510.2.8	1	0,05	2	7	15	35	2	5	105125	▲		▲
R105.0515.1.8	1,5	0,05	2	7	10	25	3	5	105125	▲		▲
R105.0515.2.8	1,5	0,05	2	7	15	35	3	5	105125	▲		▲
R105.0520.1.8	2	0,05	2	7	10	25	5	5	105125	▲		▲
R105.0520.2.8	2	0,05	2	7	15	35	5	5	105125	▲		▲
L105.0510.1.8	1	0,05	2	7	10	25	2	5	105125	▲		▲
L105.0510.2.8	1	0,05	2	7	15	35	2	5	105125	Δ		▲
L105.0515.1.8	1,5	0,05	2	7	10	25	3	5	105125	▲		▲
L105.0515.2.8	1,5	0,05	2	7	15	35	3	5	105125	▲		▲
L105.0520.1.8	2	0,05	2	7	10	25	5	5	105125	▲		▲
L105.0520.2.8	2	0,05	2	7	15	35	5	5	105125	▲		▲
P										●	●	●
M										●	●	●
K										○	○	●
N										-	-	●
S										-	-	●
H										-	-	-

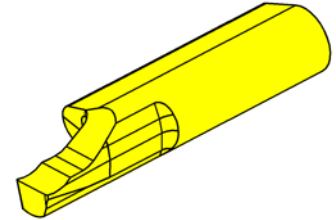
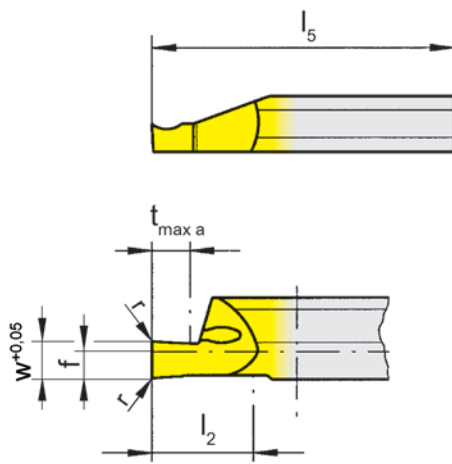
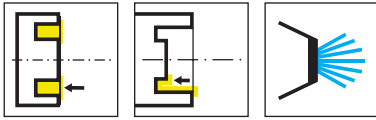

R = version à droite représentée  
R = versione destra come in figura

L = version à gauche  
L = versione sinistra a specchio

▲ en stock  
a stock

Nuance  
Leghe  
Δ 4 semaines  
4 settimane

Numéro de commande Codice prodotto	w	r	f	b	l <sub>2</sub>	l <sub>5</sub>	t <sub>max a</sub>	D <sub>a min</sub>	HIS	Nuance Leghe	
										EG35	TI25
R105.0610.1.8	1	0,05	2	7	10	25	2	6	105125	▲	▲
R105.0615.1.8	1,5	0,05	2	7	10	25	3	6	105125	▲	▲
R105.0620.1.8	2	0,05	2	7	10	25	5	6	105125	▲	▲
R105.0610.2.8	1	0,05	2	7	15	35	2	6	105125	▲	▲
R105.0615.2.8	1,5	0,05	2	7	15	35	3	6	105125	▲	▲
R105.0620.2.8	2	0,05	2	7	15	35	5	6	105125	▲	▲
L105.0610.1.8	1	0,05	2	7	10	25	2	6	105125	▲	▲
L105.0615.1.8	1,5	0,05	2	7	10	25	3	6	105125	▲	▲
L105.0620.1.8	2	0,05	2	7	10	25	5	6	105125	▲	▲
L105.0610.2.8	1	0,05	2	7	15	35	2	6	105125	Δ	▲
L105.0615.2.8	1,5	0,05	2	7	15	35	3	6	105125	Δ	▲
L105.0620.2.8	2	0,05	2	7	15	35	5	6	105125	Δ	▲
										P	●
										M	●
										K	●
										N	-
										S	-
										H	-

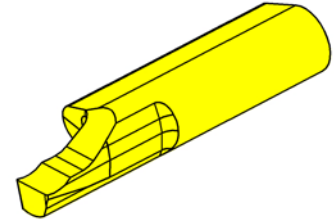
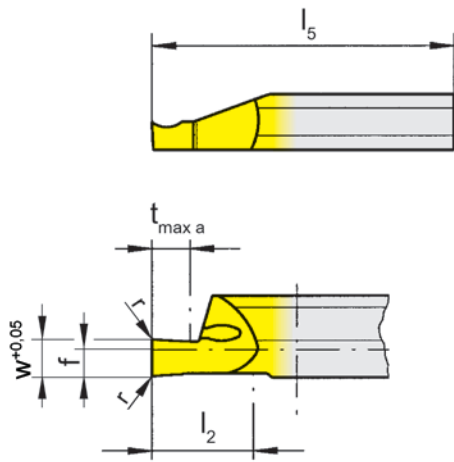
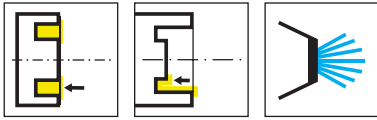

R = version à droite représentée  
R = versione destra come in figura

L = version à gauche  
L = versione sinistra a specchio

Nuance  
Leghe  
▲ en stock  
a stock  
Δ 4 semaines  
4 settimane

Número de commande Codice prodotto	w	r	f	b	l <sub>2</sub>	l <sub>5</sub>	t <sub>max a</sub>	D <sub>a min</sub>	HIS	EG35	TI25
R105.0810.1.8	1	0,15	2	7	10	25	2	8	105125	▲	▲
R105.0815.1.8	1,5	0,15	2	7	10	25	3	8	105125	▲	▲
R105.0820.1.8	2	0,15	2	7	10	25	4	8	105125	▲	▲
R105.0825.1.8	2,5	0,15	2	7	10	25	5	8	105125	▲	▲
R105.0830.1.8	3	0,15	2	7	10	25	6	8	105125	▲	▲
R105.0810.2.8	1	0,15	2	7	15	35	2	8	105125	▲	▲
R105.0815.2.8	1,5	0,15	2	7	15	35	3	8	105125	▲	▲
R105.0820.2.8	2	0,15	2	7	15	35	4	8	105125	▲	▲
R105.0825.2.8	2,5	0,15	2	7	15	35	5	8	105125	▲	▲
R105.0830.2.8	3	0,15	2	7	15	35	6	8	105125	▲	▲
L105.0810.1.8	1	0,15	2	7	10	25	2	8	105125	▲	▲
L105.0815.1.8	1,5	0,15	2	7	10	25	3	8	105125	▲	▲
L105.0820.1.8	2	0,15	2	7	10	25	4	8	105125	▲	▲
L105.0825.1.8	2,5	0,15	2	7	10	25	5	8	105125	▲	▲
L105.0830.1.8	3	0,15	2	7	10	25	6	8	105125	▲	▲
L105.0810.2.8	1	0,15	2	7	15	35	2	8	105125	▲	▲
L105.0815.2.8	1,5	0,15	2	7	15	35	3	8	105125	▲	▲
L105.0820.2.8	2	0,15	2	7	15	35	4	8	105125	▲	▲
L105.0825.2.8	2,5	0,15	2	7	15	35	5	8	105125	▲	▲
L105.0830.2.8	3	0,15	2	7	15	35	6	8	105125	▲	▲
P	●	●									
M	●	●									
K	○	●									
N	-	●									
S	-	●									
H	-	-									

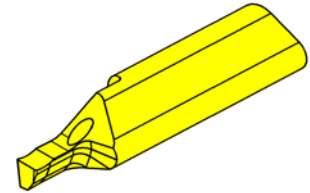
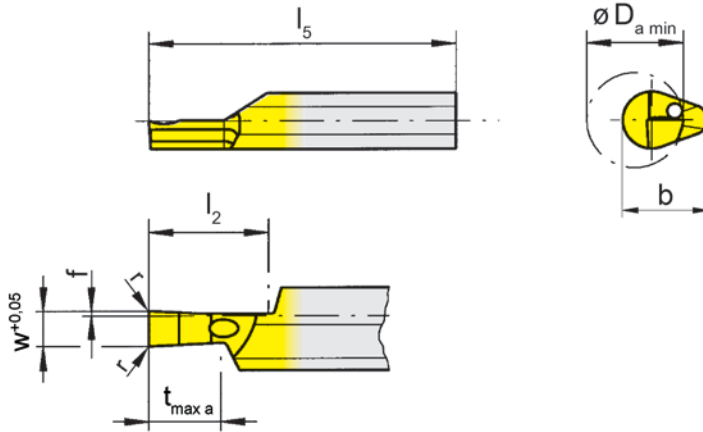
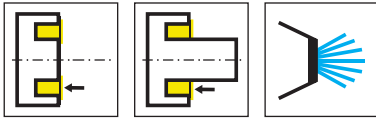

R = version à droite représentée  
R = versione destra come in figura

L = version à gauche  
L = versione sinistra a specchio

▲ en stock  
a stock

Nuance  
Leghe  
Δ 4 semaines  
4 settimane

Numéro de commande Codice prodotto	w	r	f	b	l <sub>2</sub>	l <sub>5</sub>	t <sub>max a</sub>	D <sub>a min</sub>	HIS	Nuance	
										EG35	TI25
R105.0810.1.9	1	0,15	0,4	7	10	25	2	8	105125	▲	▲
R105.0815.1.9	1,5	0,15	0,4	7	10	25	3	8	105125	▲	▲
R105.0820.1.9	2	0,15	0,4	7	10	25	4	8	105125	▲	▲
R105.0825.1.9	2,5	0,15	0,4	7	10	25	5	8	105125	▲	▲
R105.0830.1.9	3	0,15	0,4	7	10	25	6	8	105125	▲	▲
L105.0810.1.9	1	0,15	0,4	7	10	25	2	8	105125	▲	▲
L105.0815.1.9	1,5	0,15	0,4	7	10	25	3	8	105125	▲	▲
L105.0820.1.9	2	0,15	0,4	7	10	25	4	8	105125	▲	▲
L105.0825.1.9	2,5	0,15	0,4	7	10	25	5	8	105125	▲	▲
L105.0830.1.9	3	0,15	0,4	7	10	25	6	8	105125	▲	▲
										P	● ●
										M	● ●
										K	○ ●
										N	- ●
										S	- ●
										H	- -

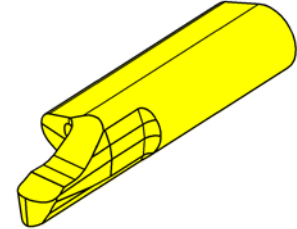
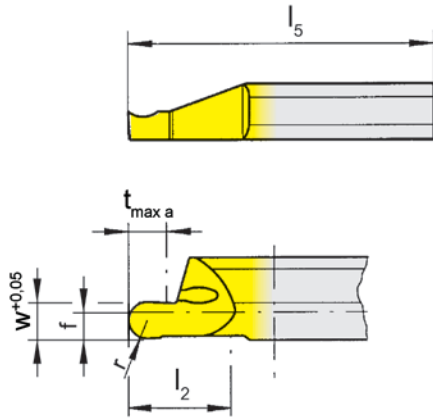
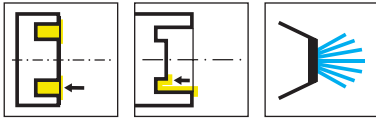

R = version à droite représentée  
R = versione destra come in figura

L = version à gauche  
L = versione sinistra a specchio

▲ en stock  
a stock

Nuance  
Leghe  
Δ 4 semaines  
4 settimane

Numéro de commande Codice prodotto	w	r	f	b	l <sub>2</sub>	l <sub>5</sub>	t <sub>max a</sub>	D <sub>a min</sub>	HIS	Nuance	
										EG35	TI25
R105.8V10.1.8	1	0,5	2	7	10	25	2	8	105125	▲	▲
R105.8V16.1.8	1,6	0,8	2	7	10	25	3	8	105125	▲	▲
R105.8V20.1.8	2	1	2	7	10	25	4	8	105125	▲	▲
R105.8V25.1.8	2,5	1,25	2	7	10	25	5	8	105125	▲	▲
R105.8V30.1.8	3	1,5	2	7	10	25	6	8	105125	▲	▲
R105.8V10.2.8	1	0,5	2	7	15	35	2	8	105125	▲	▲
R105.8V16.2.8	1,6	0,8	2	7	15	35	3	8	105125	▲	▲
R105.8V20.2.8	2	1	2	7	15	35	4	8	105125	▲	▲
R105.8V25.2.8	2,5	1,25	2	7	15	35	5	8	105125	▲	▲
R105.8V30.2.8	3	1,5	2	7	15	35	6	8	105125	▲	▲
L105.8V10.1.8	1	0,5	2	7	10	25	2	8	105125	▲	▲
L105.8V16.1.8	1,6	0,8	2	7	10	25	3	8	105125	▲	▲
L105.8V20.1.8	2	1	2	7	10	25	4	8	105125	▲	▲
L105.8V25.1.8	2,5	1,25	2	7	10	25	5	8	105125	Δ	▲
L105.8V30.1.8	3	1,5	2	7	10	25	6	8	105125	▲	▲
L105.8V10.2.8	1	0,5	2	7	15	35	2	8	105125	Δ	▲
L105.8V16.2.8	1,6	0,8	2	7	15	35	3	8	105125	Δ	▲
L105.8V20.2.8	2	1	2	7	15	35	4	8	105125	▲	▲
L105.8V25.2.8	2,5	1,25	2	7	15	35	5	8	105125	Δ	Δ
L105.8V30.2.8	3	1,5	2	7	15	35	6	8	105125	Δ	▲
P	●	●									
M	●	●									
K	○	●									
N	-	●									
S	-	●									
H	-	-									

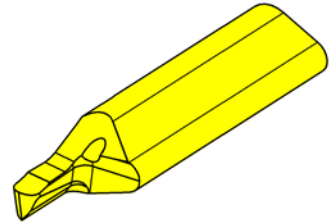
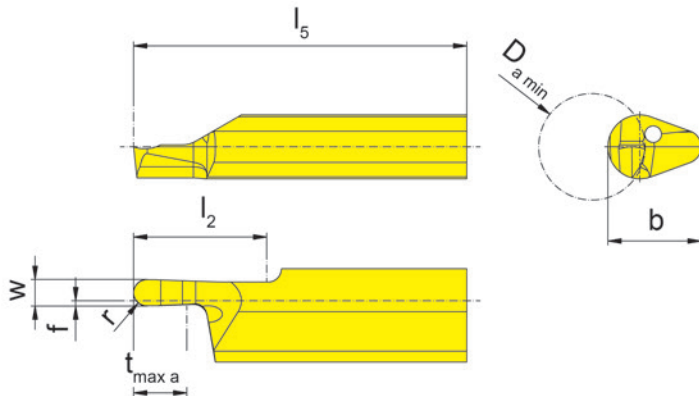
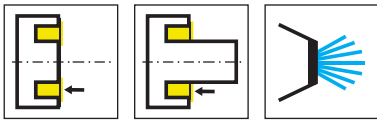

R = version à droite représentée  
R = versione destra come in figura

L = version à gauche  
L = versione sinistra a specchio

▲ en stock  
a stock

Nuance  
Leghe  
Δ 4 semaines  
4 settimane

Numéro de commande Codice prodotto	w	r	f	b	$l_2$	$l_5$	$t_{\max a}$	$D_{a \min}$	HIS	EG35
R105.8V10.1.9	1	0,5	0,4	7	10	25	2	8	105125	▲
R105.8V16.1.9	1,6	0,8	0,4	7	10	25	3	8	105125	▲
R105.8V20.1.9	2	1	0,4	7	10	25	4	8	105125	▲
R105.8V25.1.9	2,5	1,25	0,4	7	10	25	5	8	105125	▲
R105.8V30.1.9	3	1,5	1	7	10	25	6	8	105125	▲
L105.8V10.1.9	1	0,5	0,4	7	10	25	2	8	105125	▲
L105.8V16.1.9	1,6	0,8	0,4	7	10	25	3	8	105125	▲
L105.8V20.1.9	2	1	0,4	7	10	25	4	8	105125	▲
L105.8V25.1.9	2,5	1,25	0,4	7	10	25	5	8	105125	▲
L105.8V30.1.9	3	1,5	1	7	10	25	6	8	105125	▲
										P ●
										M ●
										K ○
										N -
										S -
										H -

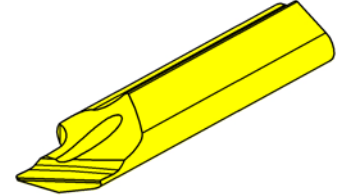
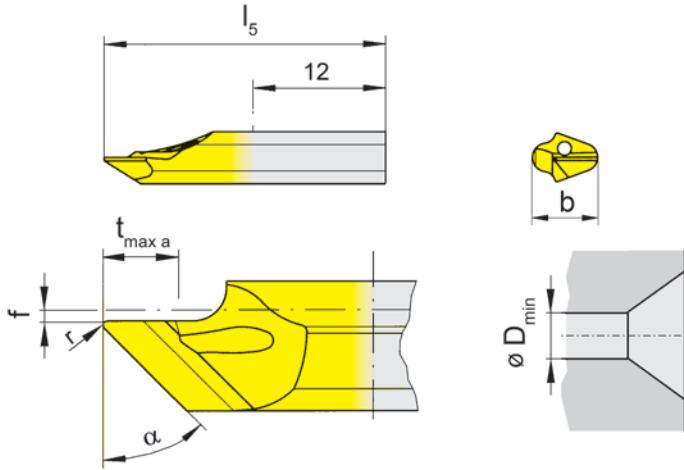
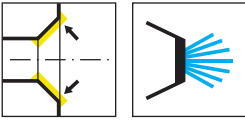

R = version à droite représentée  
R = versione destra come in figura

L = version à gauche  
L = versione sinistra a specchio

▲ en stock  
a stock

Nuance  
Leghe  
Δ 4 semaines  
4 settimane

Numéro de commande Codice prodotto	r	f	b	l <sub>5</sub>	t <sub>max a</sub>	D <sub>min</sub>	α	HIS	Nuance Leghe		
									EG35	TH35	TN35
R105.0045.0.1	0,2	0,5	5,9	20	3,5	1	45°	105123	▲	▲	▲
R105.0045.1.1	0,2	0,5	5,9	25	3,5	1	45°	105123	▲	▲	
R105.0060.0.1	0,2	0,5	5,9	20	4	1	60°	105123	▲	▲	
R105.0060.1.1	0,2	0,5	5,9	25	4	1	60°	105123	▲	▲	
L105.0045.0.1	0,2	0,5	5,9	20	3,5	1	45°	105123	▲	▲	▲
L105.0045.1.1	0,2	0,5	5,9	25	3,5	1	45°	105123	▲	▲	
L105.0060.0.1	0,2	0,5	5,9	20	4	1	60°	105123	▲	▲	
L105.0060.1.1	0,2	0,5	5,9	25	4	1	60°	105123	▲	▲	
P	●	●	●								
M	●	●	●								
K	○	●	●								
N	-	●	●								
S	-	●	●								
H	-	-	-								

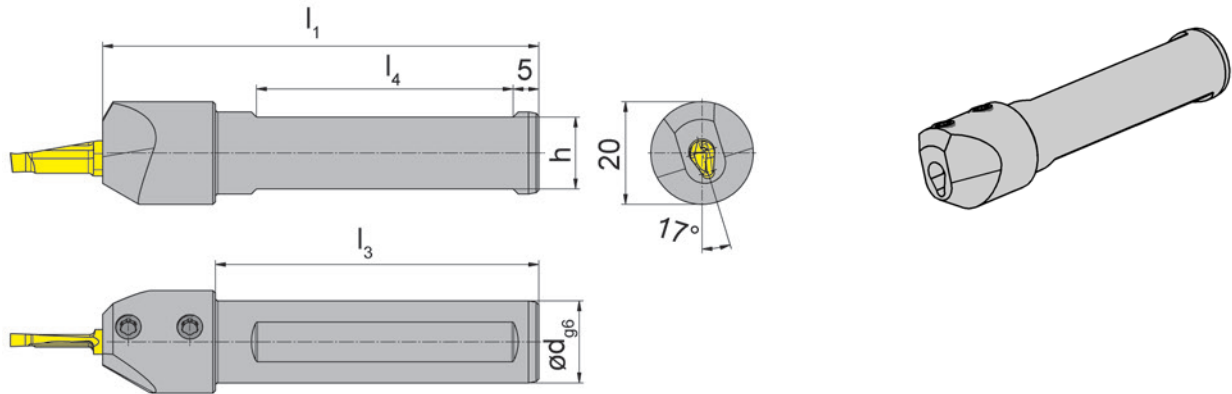
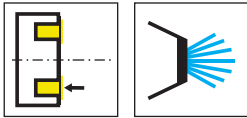

L = version à gauche représentée  
 L = versione sinistra come in figura

R = version à droite  
 R = versione destra a specchio

Numéro de commande Codice prodotto	d	l <sub>1</sub>	l <sub>3</sub>	h	l <sub>4</sub>	HWS
<b>RB105.0016.12.2</b>	16	85	63	14	50	105225
<b>RB105.0020.12.2</b>	20	100	-	18	55	105225
<b>LB105.0016.12.2</b>	16	85	63	14	50	105225
<b>LB105.0020.12.2</b>	20	100	-	18	55	105225

**Pièces Détachées**

Ricambi

Porte outils Portainsero	Vis de serrage Vite di serraggio	Tournevis TORX PLUS® Cacciavite TORX PLUS®
R/LB105...	<b>6.075T15P</b>	<b>T15PQ</b>

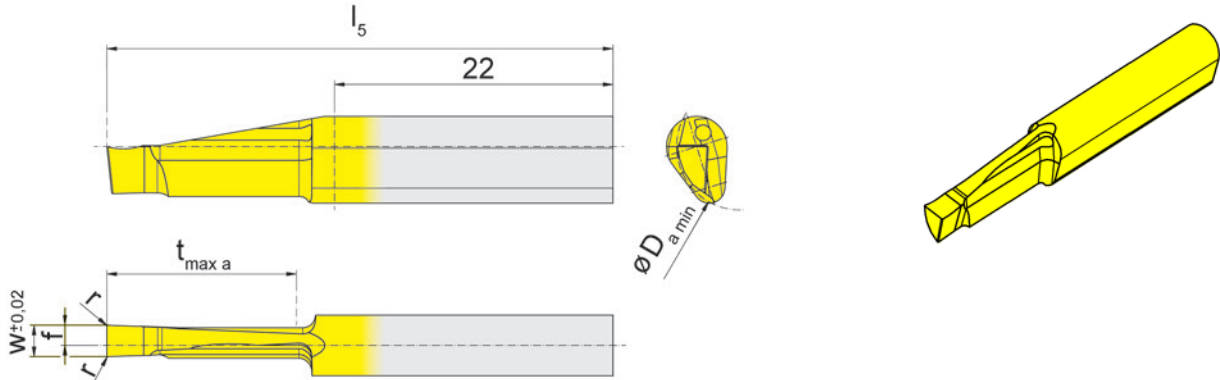
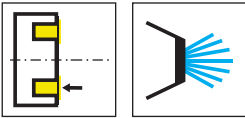

L = version à gauche représentée  
L = versione sinistra come in figura

R = version à droite  
R = versione destra a specchio

▲ en stock  
a stock

Nuance  
Leghe  
Δ 4 semaines  
4 settimane

Numéro de commande Codice prodotto	w	r	f	l <sub>5</sub>	t <sub>max a</sub>	D <sub>a min</sub>	D <sub>a max</sub>	HIS		
									EG35	TI25
RA105.1020.2.2	2	0,1	1,4	40	15	10	44	105225	▲	▲
RA105.1025.2.2	2,5	0,1	1,6	40	15	10	45	105225	▲	▲
RA105.1030.2.2	3	0,1	1	40	15	10	46	105225	▲	▲
LA105.1020.2.2	2	0,1	1,4	40	15	10	44	105225	▲	▲
LA105.1025.2.2	2,5	0,1	1,6	40	15	10	45	105225	▲	▲
LA105.1030.2.2	3	0,1	1	40	15	10	46	105225	▲	▲

Gorge frontale sur toute la profondeur possible uniquement Da min 10 - 40 mm!  
Gole frontali con larghezza e profondità max, sono solo possibili se tra Da min 10 - 40 mm!

P	●	●
M	●	●
K	○	●
N	-	●
S	-	●
H	-	-

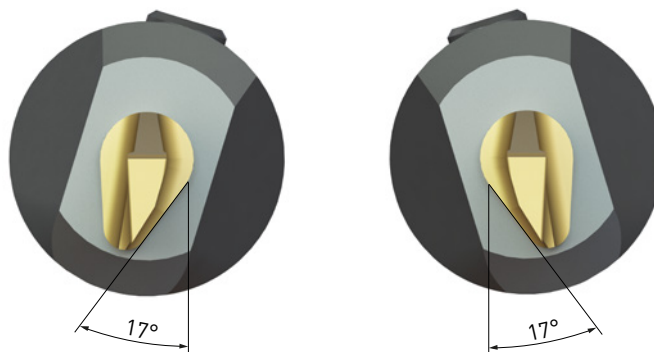

RA105 → RB105

LA105 → LB105

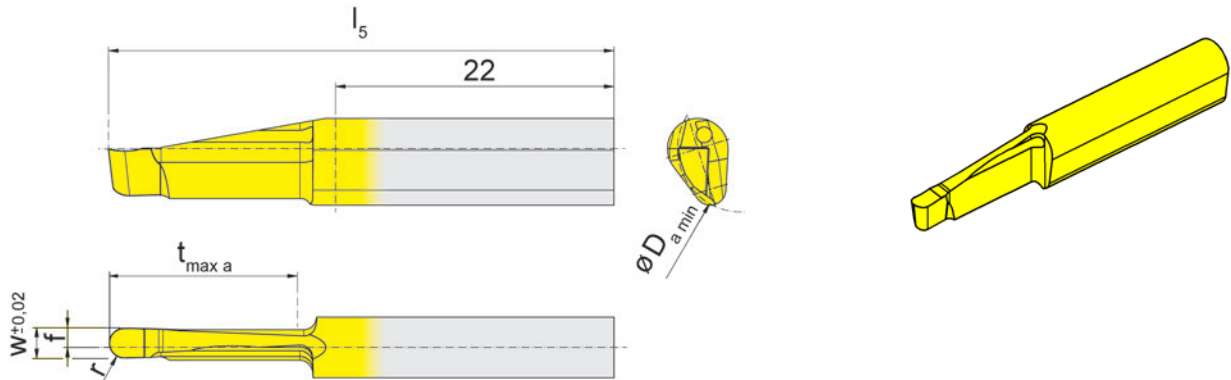
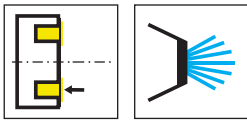

L = version à gauche représentée  
L = versione sinistra come in figura

R = version à droite  
R = versione destra a specchio

▲ en stock  
a stock

Nuance  
Leghe  
Δ 4 semaines  
4 settimane

Numéro de commande Codice prodotto	w	r	f	$l_5$	$t_{max a}$	$D_{a min}$	$D_{a max}$	HIS		
									EG35	TI25
RA105.1020.10.2.2	2	1	1,4	40	15	10	44	105225	▲	▲
RA105.1025.12.2.2	2,5	1,25	1,6	40	15	10	45	105225	Δ	▲
RA105.1030.15.2.2	3	1,5	1,9	40	15	10	46	105225	▲	▲
LA105.1020.10.2.2	2	1	1,4	40	15	10	44	105225	Δ	▲
LA105.1025.12.2.2	2,5	1,25	1,6	40	15	10	45	105225	Δ	Δ
LA105.1030.15.2.2	3	1,5	1,9	40	15	10	46	105225	Δ	▲

Gorge frontale sur toute la profondeur possible uniquement  $D_{a min}$  10 - 40 mm!  
Gole frontali con larghezza e profondità max, sono solo possibili se tra  $D_{a min}$  10 - 40 mm!

P	●	●
M	●	●
K	○	●
N	-	●
S	-	●
H	-	-

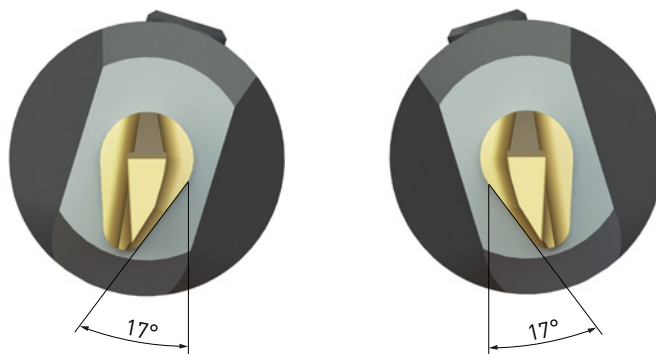

RA105 → RB105

LA105 → LB105

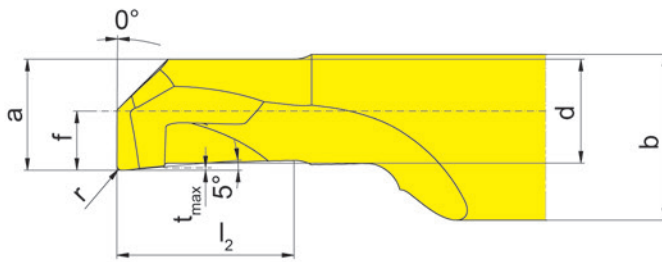
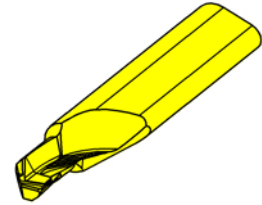
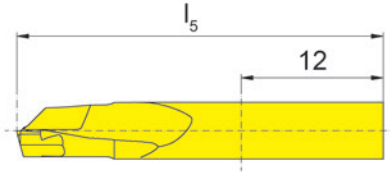
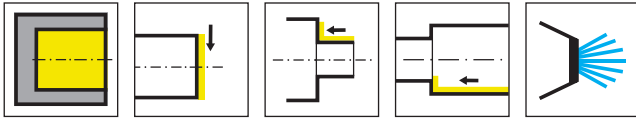

R = version à droite représentée  
R = versione destra come in figura

L = version à gauche  
L = versione sinistra a specchio

▲ en stock  
a stock

Nuance  
Leghe  
Δ 4 semaines  
4 settimane

Numéro de commande Codice prodotto	r	f	a	d	b	l <sub>2</sub>	l <sub>5</sub>	t <sub>max</sub>	Ds	HIS	EG35
R105.BO.30.20.045.1	0,2	1,5	2,7	2,4	7	4,5	31	0,1	3	105125	▲
R105.BO.30.20.075.1	0,2	1,5	2,7	2,4	7	7,5	31	0,1	3	105125	▲
R105.BO.40.20.060.1	0,2	2	3,7	3,4	7	6	31	0,1	4	105125	▲
R105.BO.40.20.100.1	0,2	2	3,7	3,4	7	10	31	0,1	4	105125	▲
R105.BO.50.20.075.1	0,2	2,5	4,7	4,4	7	7,5	31	0,1	5	105125	▲
R105.BO.50.20.125.1	0,2	2,5	4,7	4,4	7	12,5	36	0,1	5	105125	▲
R105.BO.60.20.090.1	0,2	3	5,4	5,1	7	9	31	0,1	6	105125	▲
R105.BO.60.20.150.1	0,2	3	5,4	5,1	7	15	36	0,1	6	105125	▲
R105.BO.70.20.105.1	0,2	3,5	5,9	5,6	7	10,5	36	0,1	7	105125	▲
R105.BO.70.20.175.1	0,2	3,5	5,9	5,6	7	17,5	40	0,1	7	105125	▲
L105.BO.30.20.045.1	0,2	1,5	2,7	2,4	7	4,5	31	0,1	3	105125	Δ
L105.BO.30.20.075.1	0,2	1,5	2,7	2,4	7	7,5	31	0,1	3	105125	Δ
L105.BO.40.20.060.1	0,2	2	3,7	3,4	7	6	31	0,1	4	105125	Δ
L105.BO.40.20.100.1	0,2	2	3,7	3,4	7	10	31	0,1	4	105125	Δ
L105.BO.50.20.075.1	0,2	2,5	4,7	4,4	7	7,5	31	0,1	5	105125	Δ
L105.BO.50.20.125.1	0,2	2,5	4,7	4,4	7	12,5	36	0,1	5	105125	Δ
L105.BO.60.20.090.1	0,2	3	5,4	5,1	7	9	31	0,1	6	105125	Δ
L105.BO.60.20.150.1	0,2	3	5,4	5,1	7	15	36	0,1	6	105125	Δ
L105.BO.70.20.105.1	0,2	3,5	5,9	5,6	7	10,5	36	0,1	7	105125	Δ
L105.BO.70.20.175.1	0,2	3,5	5,9	5,6	7	17,5	40	0,1	7	105125	Δ

avec arrosage central, de diamètre de coupe 5 mm  
con foro per la lubrificazione interna, da diametro 5 mm

avec brise copeaux  
con rompitrucciolo

P	●
M	●
K	○
N	-
S	-
H	-

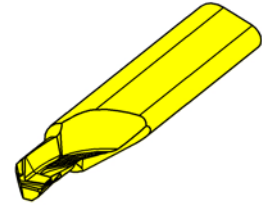
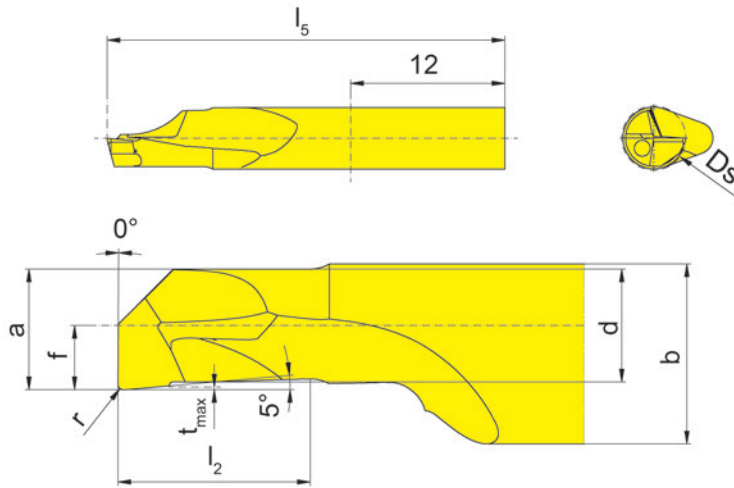
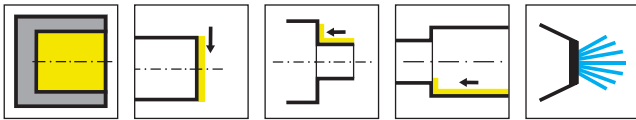

R = version à droite représentée  
R = versione destra come in figura

L = version à gauche  
L = versione sinistra a specchio

▲ en stock  
a stock

Nuance  
Leghe  
Δ 4 semaines  
4 settimane

Número de commande Codice prodotto	r	f	a	d	b	$l_2$	$l_5$	$t_{max}$	Ds	HIS	EG35
R105.BO.30.20.045.2	0,2	1,5	2,7	2,4	7	4,5	31	0,1	3	105125	▲
R105.BO.30.20.075.2	0,2	1,5	2,7	2,4	7	7,5	31	0,1	3	105125	▲
R105.BO.40.20.060.2	0,2	2	3,7	3,4	7	6	31	0,1	4	105125	▲
R105.BO.40.20.100.2	0,2	2	3,7	3,4	7	10	31	0,1	4	105125	▲
R105.BO.50.20.075.2	0,2	2,5	4,7	4,4	7	7,5	31	0,1	5	105125	▲
R105.BO.50.20.125.2	0,2	2,5	4,7	4,4	7	12,5	36	0,1	5	105125	▲
R105.BO.60.20.090.2	0,2	3	5,4	5,1	7	9	31	0,1	6	105125	▲
R105.BO.60.20.150.2	0,2	3	5,4	5,1	7	15	36	0,1	6	105125	▲
R105.BO.70.20.105.2	0,2	3,5	5,9	5,6	7	10,5	36	0,1	7	105125	▲
R105.BO.70.20.175.2	0,2	3,5	5,9	5,6	7	17,5	40	0,1	7	105125	▲
L105.BO.30.20.045.2	0,2	1,5	2,7	2,4	7	4,5	31	0,1	3	105125	Δ
L105.BO.30.20.075.2	0,2	1,5	2,7	2,4	7	7,5	31	0,1	3	105125	Δ
L105.BO.40.20.060.2	0,2	2	3,7	3,4	7	6	31	0,1	4	105125	Δ
L105.BO.40.20.100.2	0,2	2	3,7	3,4	7	10	31	0,1	4	105125	Δ
L105.BO.50.20.075.2	0,2	2,5	4,7	4,4	7	7,5	31	0,1	5	105125	Δ
L105.BO.50.20.125.2	0,2	2,5	4,7	4,4	7	12,5	36	0,1	5	105125	Δ
L105.BO.60.20.090.2	0,2	3	5,4	5,1	7	9	31	0,1	6	105125	Δ
L105.BO.60.20.150.2	0,2	3	5,4	5,1	7	15	36	0,1	6	105125	Δ
L105.BO.70.20.105.2	0,2	3,5	5,9	5,6	7	10,5	36	0,1	7	105125	Δ
L105.BO.70.20.175.2	0,2	3,5	5,9	5,6	7	17,5	40	0,1	7	105125	Δ

avec arrosage central, de diamètre de coupe 5 mm  
con foro per la lubrificazione interna, da diametro 5 mm

Géométrie universelle  
Geometria universale

P	●
M	●
K	○
N	-
S	-
H	-

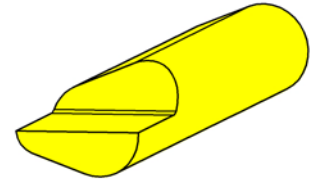
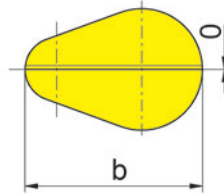
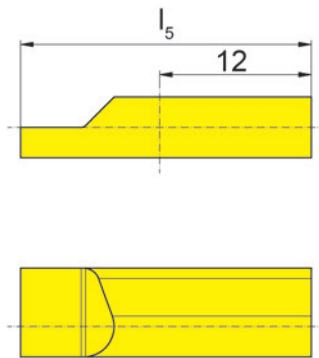
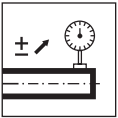

R = version à droite représentée

R = versione destra come in figura

Numéro de commande Codice prodotto	$l_5$	b	HIS
R105.LEHR.H.03	25	5,9	105123
R105.LEHR.H.04	25	6,4	105124
R105.LEHR.H.05	25	7,0	105125
L105.LEHR.H.03	25	5,9	105123
L105.LEHR.H.04	25	6,4	105124
L105.LEHR.H.05	25	7,0	105125

Plaquette pour réglage des porte outils.  
Inserto master per pre-setting

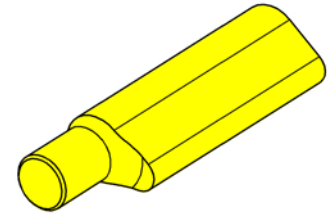
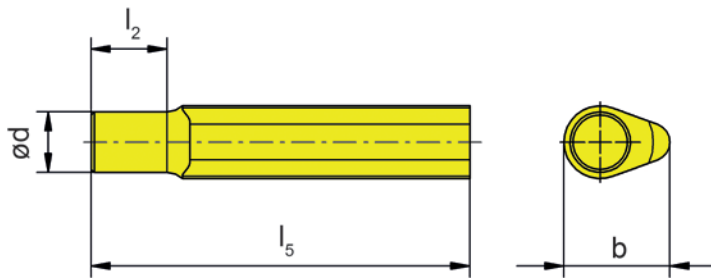
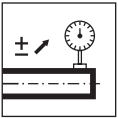

Número de commande Codice prodotto	d	b	$l_2$	$l_5$	HIS
105.LEHR.D.03	1,7	5,9	3	25	105123
105.LEHR.D.04	1,7	6,4	3	25	105124
105.LEHR.D.05	4	7	5	25	105125

Plaquette pour réglage des porte outils.  
Inserto master per pre-setting

**109**



**Porte outils et plaquettes**

**Portainsero e inserti**

Porte outils  
Portainsero  
B109

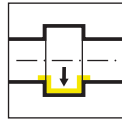

Page/Pag.  
156-157

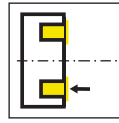

Page/Pag.  
173

Plaquette  
Inserto  
109/A109

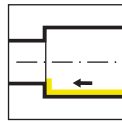

Page/Pag.  
158-159



Page/Pag.  
160-161

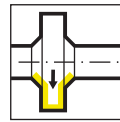

Page/Pag.  
162

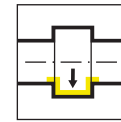

Page/Pag.  
163-166

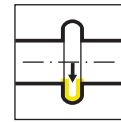

Page/Pag.  
167

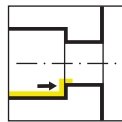

Page/Pag.  
168

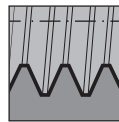

Page/Pag.  
169-170

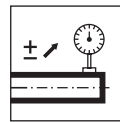

Page/Pag.  
171-172

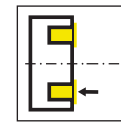

Page/Pag.  
174

Ø Alésage Foro Ø	Type de produit / Linea di prodotto											
	105	109	110	106	107	108	10P	111	11P	114	116	18P
≥ 0,2	•											
≥ 0,5	•											
≥ 0,7	•											
≥ 1,0	•											
≥ 1,5	•											
≥ 2,0	•											
≥ 3,0	•											
≥ 4,0	•											
≥ 5,0	•											
≥ 6,0	•	•	•	•								
≥ 6,8		•	•	•								
≥ 7,0		•			•							
≥ 7,8			•		•	•						
≥ 8,0			•		•	•						
≥ 9,0			•		•	•	•					
≥ 10,0			•				•	•	•			
≥ 10,5									•			
≥ 11,0								•	•			
≥ 11,5									•			
≥ 13,8										•		
≥ 14,0										•	•	
≥ 16,0											•	
≥ 16,5										{•}		
≥ 18,0												•
Profondeur de gorge Profondità della gola	2,5	2,5	4,0	0,8	2,0	1,0	3,0	2,3	3,5	4,0 (6,5)	4,3	8,0
Largeur de gorge Larghezza della gola	0,5- 2,0	1,0- 2,0	1,0- 3,0	0,7- 1,5	1,0- 2,0	0,7- 2,0	1,0- 3,0	0,7- 3,0	1,0- 3,0	0,7- 3,0	0,7- 4,0	2,0- 3,0
Type d'usinage / Operazione												
Gorge Gole	•	•	•	•	•	•	•	•	•	•	•	•
Alésage Alesatura	•	•	•	•	•	•			•	•	•	
Filetage Filettatura	•	•			•	•			•	•	•	
Chanfreinage Smussatura	•	•			•	•			•	•	•	
Gorge frontale Gole assiali	•	•	•							•		
Tournage dur Alesatura e profilatura	•											

B

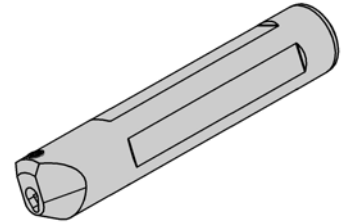
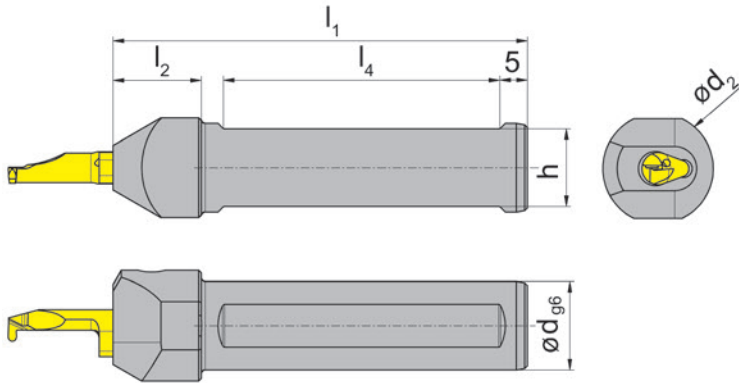
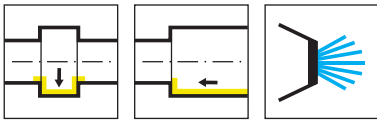

Illustration de coupe à droite représentée  
Figura = taglio destro

N° de commande Codice prodotto	d	l <sub>1</sub>	h	l <sub>4</sub>	l <sub>2</sub>	d <sub>2</sub>	HWS
B109.0012.01	12	75	10	50	16	20	109140
B109.0016.01	16	75	14	50	16	20	109140
B109.0020.01	20	90	18	55	-	20	109140
B109.0025.01	25	100	23	55	-	25	109140

### Pièces Détachées

Ricambi

Porte outils Portainsero	Vis de serrage Vite di serraggio	Tournevis TORX PLUS® Cacciavite TORX PLUS®
B109...	6.075T15P	T15PQ

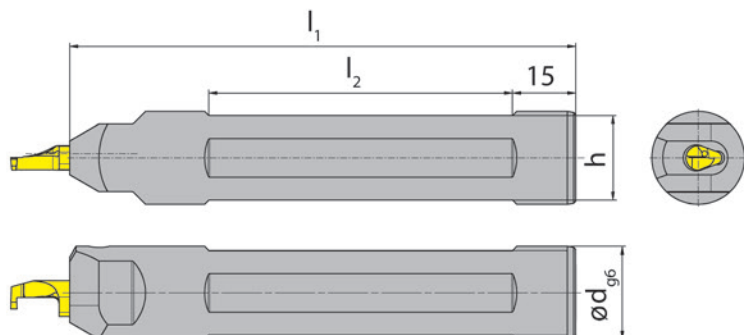
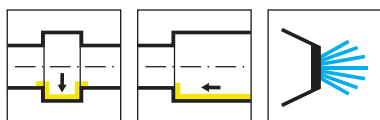

Illustration de coupe à droite représentée

Figura = taglio destro

N° de commande Codice prodotto	d	l <sub>1</sub>	h	l <sub>2</sub>	HWS
B109.0022.1.2.01	22	120	20	72	109140

### Pièces Détachées

Ricambi

Porte outils Portainsero	Vis de serrage Vite di serraggio	Tournevis TORX PLUS® Cacciavite TORX PLUS®
B109.0022.1.2.01	6.075T15P	T15PQ

B

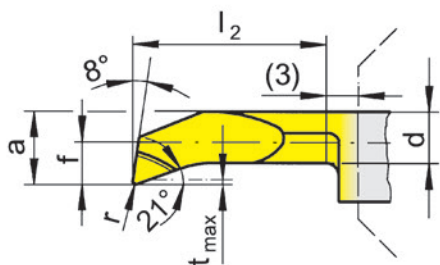
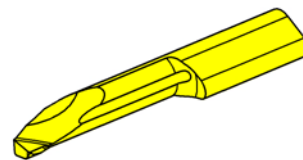
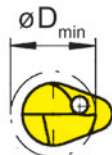
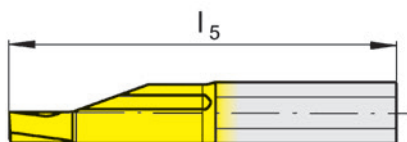
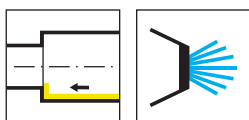

Nuance  
Leghe

R = version à droite représentée  
R = versione destra come in figura

L = version à gauche  
L = versione sinistra a specchio

▲ en stock  
a stock

Δ 4 semaines  
4 settimane

N° de commande Codice prodotto	r	f	a	d	l <sub>2</sub>	l <sub>5</sub>	t <sub>max</sub>	D <sub>min</sub>	HIS	TH35
R109.1828.1.6	0,2	2,8	5,7	5	10	28	0,4	6	109140	Δ
R109.1828.2.6	0,2	2,8	5,7	5	15	33	0,4	6	109140	Δ
R109.1828.3.6	0,2	2,8	5,7	5	20	38	0,4	6	109140	▲
R109.1828.4.6	0,2	2,8	5,7	5	25	43	0,4	6	109140	Δ
R109.1828.5.6	0,2	2,8	5,7	5	30	48	0,4	6	109140	Δ
R109.1828.6.6	0,2	2,8	5,7	5	35	53	0,4	6	109140	Δ
R109.1828.7.6	0,2	2,8	5,7	5	40	58	0,4	6	109140	▲
R109.1838.2.7	0,2	3,8	6,7	6	15	33	0,4	7	109140	Δ
R109.1838.3.7	0,2	3,8	6,7	6	20	38	0,4	7	109140	Δ
R109.1838.4.7	0,2	3,8	6,7	6	25	43	0,4	7	109140	Δ
R109.1838.5.7	0,2	3,8	6,7	6	30	48	0,4	7	109140	▲
R109.1838.6.7	0,2	3,8	6,7	6	35	53	0,4	7	109140	▲
R109.1838.7.7	0,2	3,8	6,7	6	40	58	0,4	7	109140	▲
R109.1838.8.7	0,2	3,8	6,7	6	45	63	0,4	7	109140	▲
L109.1828.1.6	0,2	2,8	5,7	5	10	28	0,4	6	109140	Δ
L109.1828.2.6	0,2	2,8	5,7	5	15	33	0,4	6	109140	Δ
L109.1828.3.6	0,2	2,8	5,7	5	20	38	0,4	6	109140	Δ
L109.1828.5.6	0,2	2,8	5,7	5	30	48	0,4	6	109140	Δ
L109.1828.6.6	0,2	2,8	5,7	5	35	53	0,4	6	109140	Δ
L109.1828.7.6	0,2	2,8	5,7	5	40	58	0,4	6	109140	Δ
L109.1838.2.7	0,2	3,8	6,7	6	15	33	0,4	7	109140	Δ
L109.1838.3.7	0,2	3,8	6,7	6	20	38	0,4	7	109140	Δ
L109.1838.4.7	0,2	3,8	6,7	6	25	43	0,4	7	109140	Δ
L109.1838.5.7	0,2	3,8	6,7	6	30	48	0,4	7	109140	Δ
L109.1838.6.7	0,2	3,8	6,7	6	35	53	0,4	7	109140	Δ
L109.1838.7.7	0,2	3,8	6,7	6	40	58	0,4	7	109140	Δ
L109.1838.8.7	0,2	3,8	6,7	6	45	63	0,4	7	109140	Δ

P	●
M	●
K	●
N	●
S	●
H	-

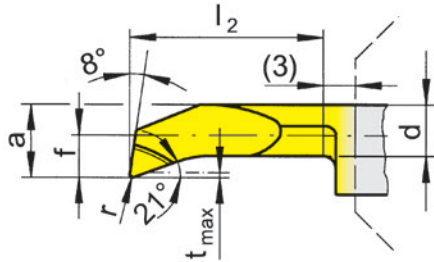
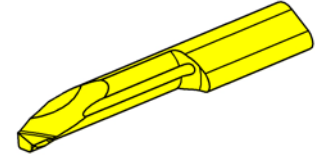
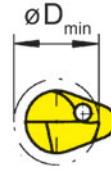
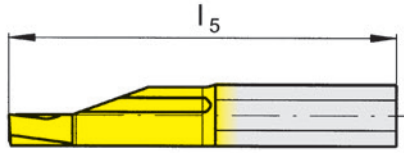
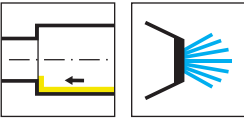

R = version à droite représentée  
R = versione destra come in figura

L = version à gauche  
L = versione sinistra a specchio

▲ en stock  
a stock

Nuance  
Leghe  
Δ 4 semaines  
4 settimane

N° de commande Codice prodotto	r	f	a	d	l <sub>2</sub>	l <sub>5</sub>	t <sub>max</sub>	D <sub>min</sub>	HIS	TH35
R109.1828.04.1.6	0,4	2,8	5,7	5	10	28	0,4	6	109140	Δ
R109.1828.04.2.6	0,4	2,8	5,7	5	15	33	0,4	6	109140	Δ
R109.1828.04.3.6	0,4	2,8	5,7	5	20	38	0,4	6	109140	Δ
R109.1828.04.4.6	0,4	2,8	5,7	5	25	43	0,4	6	109140	Δ
R109.1828.04.6.6	0,4	2,8	5,7	5	35	53	0,4	6	109140	Δ
R109.1828.04.7.6	0,4	2,8	5,7	5	40	58	0,4	6	109140	Δ
R109.1838.04.2.7	0,4	3,8	6,7	6	15	33	0,4	7	109140	Δ
R109.1838.04.3.7	0,4	3,8	6,7	6	20	38	0,4	7	109140	Δ
R109.1838.04.5.7	0,4	3,8	6,7	6	30	48	0,4	7	109140	Δ
R109.1838.04.8.7	0,4	3,8	6,7	6	45	63	0,4	7	109140	▲
L109.1828.04.1.6	0,4	2,8	5,7	5	10	28	0,4	6	109140	Δ
L109.1828.04.2.6	0,4	2,8	5,7	5	15	33	0,4	6	109140	Δ
L109.1828.04.3.6	0,4	2,8	5,7	5	20	38	0,4	6	109140	Δ
L109.1828.04.4.6	0,4	2,8	5,7	5	25	43	0,4	6	109140	Δ
L109.1828.04.6.6	0,4	2,8	5,7	5	35	53	0,4	6	109140	Δ
L109.1828.04.7.6	0,4	2,8	5,7	5	40	58	0,4	6	109140	Δ
L109.1838.04.2.7	0,4	3,8	6,7	6	15	33	0,4	7	109140	Δ
L109.1838.04.3.7	0,4	3,8	6,7	6	20	38	0,4	7	109140	Δ
L109.1838.04.8.7	0,4	3,8	6,7	6	45	63	0,4	7	109140	Δ

P	●
M	●
K	●
N	●
S	●
H	-

B

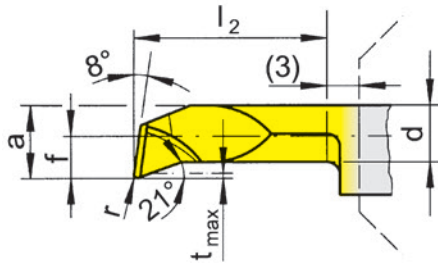
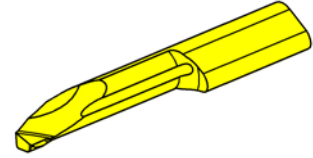
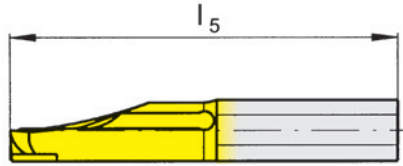
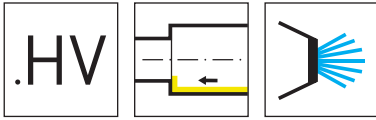

R = version à droite représentée  
R = versione destra come in figura

L = version à gauche  
L = versione sinistra a specchio

▲ en stock  
a stock

Nuance  
Leghe  
Δ 4 semaines  
4 settimane

N° de commande Codice prodotto	r	f	a	d	l <sub>2</sub>	l <sub>5</sub>	t <sub>max</sub>	D <sub>min</sub>	HIS	TH35
R109.1828.1.HV6	0,2	2,8	5,7	5	10	28	0,4	6	109140	Δ
R109.1828.2.HV6	0,2	2,8	5,7	5	15	33	0,4	6	109140	Δ
R109.1828.3.HV6	0,2	2,8	5,7	5	20	38	0,4	6	109140	Δ
R109.1828.4.HV6	0,2	2,8	5,7	5	25	43	0,4	6	109140	Δ
R109.1828.5.HV6	0,2	2,8	5,7	5	30	48	0,4	6	109140	▲
R109.1828.6.HV6	0,2	2,8	5,7	5	35	53	0,4	6	109140	▲
R109.1828.7.HV6	0,2	2,8	5,7	5	40	58	0,4	6	109140	▲
R109.1838.3.HV7	0,2	3,8	6,7	6	20	38	0,4	7	109140	Δ
R109.1838.5.HV7	0,2	3,8	6,7	6	30	48	0,4	7	109140	Δ
R109.1838.6.HV7	0,2	3,8	6,7	6	35	53	0,4	7	109140	Δ
R109.1838.7.HV7	0,2	3,8	6,7	6	40	58	0,4	7	109140	Δ
R109.1838.8.HV7	0,2	3,8	6,7	6	45	63	0,4	7	109140	Δ
L109.1828.1.HV6	0,2	2,8	5,7	5	10	28	0,4	6	109140	Δ
L109.1828.2.HV6	0,2	2,8	5,7	5	15	33	0,4	6	109140	Δ
L109.1828.3.HV6	0,2	2,8	5,7	5	20	38	0,4	6	109140	Δ
L109.1828.4.HV6	0,2	2,8	5,7	5	25	43	0,4	6	109140	Δ
L109.1828.5.HV6	0,2	2,8	5,7	5	30	48	0,4	6	109140	Δ
L109.1828.6.HV6	0,2	2,8	5,7	5	35	53	0,4	6	109140	Δ
L109.1828.7.HV6	0,2	2,8	5,7	5	40	58	0,4	6	109140	Δ
L109.1838.2.HV7	0,2	3,8	6,7	6	15	33	0,4	7	109140	Δ
L109.1838.5.HV7	0,2	3,8	6,7	6	30	48	0,4	7	109140	Δ
L109.1838.6.HV7	0,2	3,8	6,7	6	35	53	0,4	7	109140	Δ
L109.1838.7.HV7	0,2	3,8	6,7	6	40	58	0,4	7	109140	Δ
L109.1838.8.HV7	0,2	3,8	6,7	6	45	63	0,4	7	109140	Δ

P	●
M	●
K	●
N	●
S	●
H	-

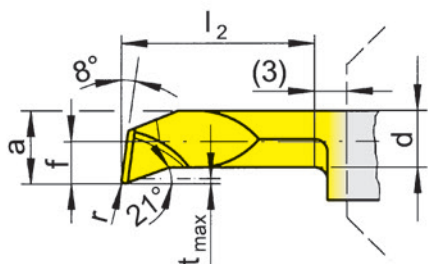
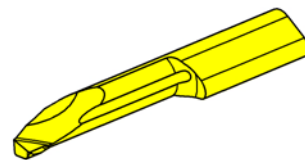
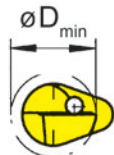
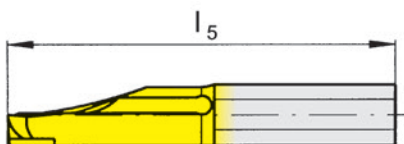
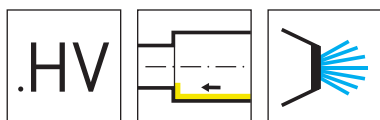

R = version à droite représentée  
R = versione destra come in figura

L = version à gauche  
L = versione sinistra a specchio

▲ en stock  
a stock

Nuance  
Leghe  
Δ 4 semaines  
4 settimane

N° de commande Codice prodotto	r	f	a	d	l <sub>2</sub>	l <sub>5</sub>	t <sub>max</sub>	D <sub>min</sub>	HIS	TH35
R109.1828.04.1.HV6	0,4	2,8	5,7	5	10	28	0,4	6	109140	Δ
R109.1828.04.2.HV6	0,4	2,8	5,7	5	15	33	0,4	6	109140	Δ
R109.1828.04.3.HV6	0,4	2,8	5,7	5	20	38	0,4	6	109140	Δ
R109.1828.04.4.HV6	0,4	2,8	5,7	5	25	43	0,4	6	109140	Δ
R109.1828.04.5.HV6	0,4	2,8	5,7	5	30	48	0,4	6	109140	Δ
R109.1828.04.6.HV6	0,4	2,8	5,7	5	35	53	0,4	6	109140	Δ
R109.1828.04.7.HV6	0,4	2,8	5,7	5	40	58	0,4	6	109140	Δ
R109.1838.04.2.HV7	0,4	3,8	6,7	6	15	33	0,4	7	109140	Δ
R109.1838.04.3.HV7	0,4	3,8	6,7	6	20	38	0,4	7	109140	Δ
R109.1838.04.4.HV7	0,4	3,8	6,7	6	25	43	0,4	7	109140	Δ
R109.1838.04.5.HV7	0,4	3,8	6,7	6	30	48	0,4	7	109140	Δ
R109.1838.04.6.HV7	0,4	3,8	6,7	6	35	53	0,4	7	109140	Δ
R109.1838.04.7.HV7	0,4	3,8	6,7	6	40	58	0,4	7	109140	Δ
R109.1838.04.8.HV7	0,4	3,8	6,7	6	45	63	0,4	7	109140	▲
L109.1828.04.1.HV6	0,4	2,8	5,7	5	10	28	0,4	6	109140	Δ
L109.1828.04.2.HV6	0,4	2,8	5,7	5	15	33	0,4	6	109140	Δ
L109.1828.04.3.HV6	0,4	2,8	5,7	5	20	38	0,4	6	109140	Δ
L109.1828.04.4.HV6	0,4	2,8	5,7	5	25	43	0,4	6	109140	Δ
L109.1828.04.5.HV6	0,4	2,8	5,7	5	30	48	0,4	6	109140	Δ
L109.1828.04.6.HV6	0,4	2,8	5,7	5	35	53	0,4	6	109140	Δ
L109.1828.04.7.HV6	0,4	2,8	5,7	5	40	58	0,4	6	109140	Δ
L109.1838.04.2.HV7	0,4	3,8	6,7	6	15	33	0,4	7	109140	Δ
L109.1838.04.3.HV7	0,4	3,8	6,7	6	20	38	0,4	7	109140	Δ
L109.1838.04.4.HV7	0,4	3,8	6,7	6	25	43	0,4	7	109140	Δ
L109.1838.04.5.HV7	0,4	3,8	6,7	6	30	48	0,4	7	109140	Δ
L109.1838.04.6.HV7	0,4	3,8	6,7	6	35	53	0,4	7	109140	Δ
L109.1838.04.7.HV7	0,4	3,8	6,7	6	40	58	0,4	7	109140	Δ

P	●
M	●
K	●
N	●
S	●
H	-

B

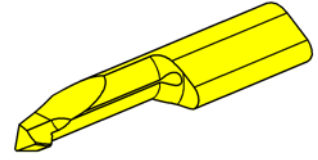
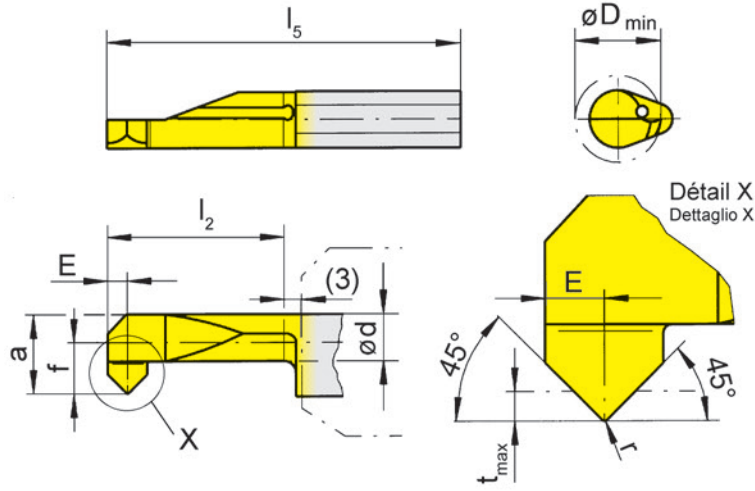
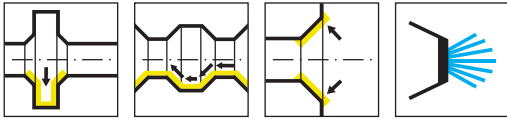

Détail X  
Dettaglio X

R = version à droite représentée  
R = versione destra come in figura

L = version à gauche  
L = versione sinistra a specchio

Nuance  
Leghe  
▲ en stock  
a stock  
Δ 4 semaines  
4 settimane

N° de commande Codice prodotto	r	f	E	a	d	l <sub>2</sub>	l <sub>5</sub>	t <sub>max</sub>	D <sub>min</sub>	HIS	TH35
R109.4545.3.6	0,2	2,8	1,2	5,7	4,3	20	38	0,9	6	109140	Δ
R109.4545.5.7	0,2	3,8	1,2	6,7	5,3	30	48	0,9	7	109140	▲
L109.4545.3.6	0,2	2,8	1,2	5,7	4,3	20	38	0,9	6	109140	Δ
L109.4545.5.7	0,2	3,8	1,2	6,7	5,3	30	48	0,9	7	109140	Δ
											P ●
											M ●
											K ●
											N ●
											S ●
											H -

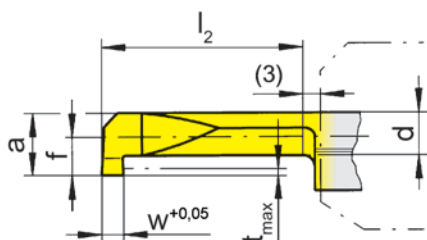
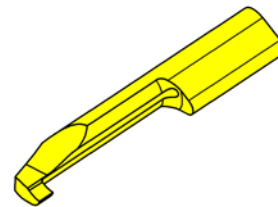
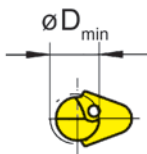
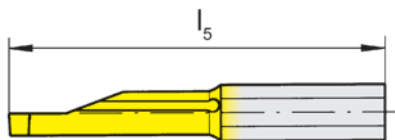
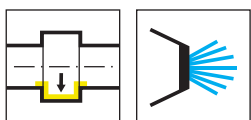

Nuance  
Leghe

R = version à droite représentée  
R = versione destra come in figura

L = version à gauche  
L = versione sinistra a specchio

▲ en stock  
a stock

Δ 4 semaines  
4 settimane

N° de commande Codice prodotto	w	f	a	d	l <sub>2</sub>	l <sub>5</sub>	t <sub>max</sub>	D <sub>min</sub>	HIS	TH35
R109.0100.1.6	1	2,8	5,7	3,7	10	28	1,8	6	109140	Δ
R109.0150.1.6	1,5	2,8	5,7	3,7	10	28	1,8	6	109140	Δ
R109.0200.1.6	2	2,8	5,7	3,7	10	28	1,8	6	109140	Δ
R109.0100.2.6	1	2,8	5,7	3,7	15	33	1,8	6	109140	Δ
R109.0150.2.6	1,5	2,8	5,7	3,7	15	33	1,8	6	109140	Δ
R109.0200.2.6	2	2,8	5,7	3,7	15	33	1,8	6	109140	Δ
R109.0100.3.6	1	2,8	5,7	3,7	20	38	1,8	6	109140	Δ
R109.0150.3.6	1,5	2,8	5,7	3,7	20	38	1,8	6	109140	Δ
R109.0200.3.6	2	2,8	5,7	3,7	20	38	1,8	6	109140	Δ
L109.0100.1.6	1	2,8	5,7	3,7	10	28	1,8	6	109140	Δ
L109.0150.1.6	1,5	2,8	5,7	3,7	10	28	1,8	6	109140	Δ
L109.0200.1.6	2	2,8	5,7	3,7	10	28	1,8	6	109140	Δ
L109.0100.2.6	1	2,8	5,7	3,7	15	33	1,8	6	109140	Δ
L109.0150.2.6	1,5	2,8	5,7	3,7	15	33	1,8	6	109140	Δ
L109.0200.2.6	2	2,8	5,7	3,7	15	33	1,8	6	109140	Δ
L109.0100.3.6	1	2,8	5,7	3,7	20	38	1,8	6	109140	Δ
L109.0150.3.6	1,5	2,8	5,7	3,7	20	38	1,8	6	109140	Δ
L109.0200.3.6	2	2,8	5,7	3,7	20	38	1,8	6	109140	Δ

P	●
M	●
K	●
N	●
S	●
H	-

B

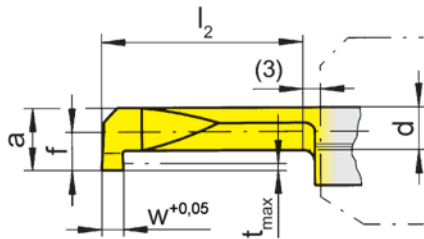
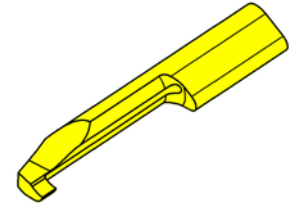
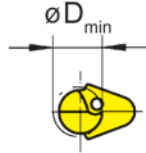
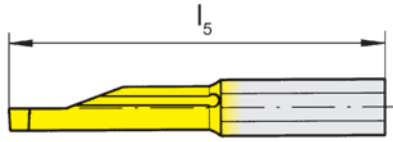
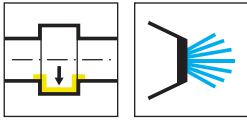

R = version à droite représentée  
R = versione destra come in figura

L = version à gauche  
L = versione sinistra a specchio

▲ en stock  
a stock

Nuance  
Leghe  
Δ 4 semaines  
4 settimane

N° de commande Codice prodotto	w	f	a	d	l <sub>2</sub>	l <sub>5</sub>	t <sub>max</sub>	D <sub>min</sub>	HIS	TH35
R109.0150.4.6	1,5	2,8	5,7	3,7	25	43	1,8	6	109140	Δ
R109.0150.5.6	1,5	2,8	5,7	3,7	30	48	1,8	6	109140	Δ
R109.0150.6.6	1,5	2,8	5,7	3,7	35	53	1,8	6	109140	Δ
R109.0200.1.6	2	2,8	5,7	3,7	10	28	1,8	6	109140	Δ
R109.0200.2.6	2	2,8	5,7	3,7	15	33	1,8	6	109140	Δ
R109.0200.3.6	2	2,8	5,7	3,7	20	38	1,8	6	109140	Δ
R109.0200.4.6	2	2,8	5,7	3,7	25	43	1,8	6	109140	Δ
R109.0200.5.6	2	2,8	5,7	3,7	30	48	1,8	6	109140	Δ
R109.0200.6.6	2	2,8	5,7	3,7	35	53	1,8	6	109140	▲
L109.0150.6.6	1,5	2,8	5,7	3,7	35	53	1,8	6	109140	Δ
L109.0200.1.6	2	2,8	5,7	3,7	10	28	1,8	6	109140	Δ
L109.0200.2.6	2	2,8	5,7	3,7	15	33	1,8	6	109140	Δ
L109.0200.3.6	2	2,8	5,7	3,7	20	38	1,8	6	109140	Δ
L109.0200.4.6	2	2,8	5,7	3,7	25	43	1,8	6	109140	Δ
L109.0200.6.6	2	2,8	5,7	3,7	35	53	1,8	6	109140	Δ
P	●									
M	●									
K	●									
N	●									
S	●									
H	-									

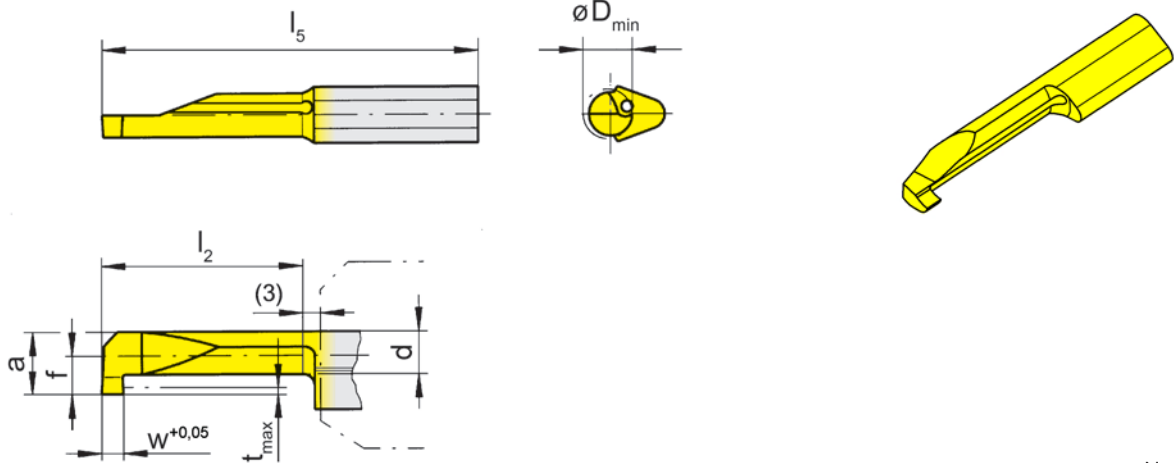
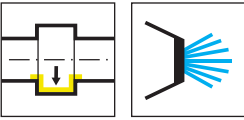

R = version à droite représentée  
R = versione destra come in figura

L = version à gauche  
L = versione sinistra a specchio

▲ en stock  
a stock

Nuance  
Leghe  
Δ 4 semaines  
4 settimane

N° de commande Codice prodotto	w	f	a	d	l <sub>2</sub>	l <sub>5</sub>	t <sub>max</sub>	D <sub>min</sub>	HIS	TH35
R109.0100.1.7	1	3,8	6,7	4	10	28	2,5	7	109140	Δ
R109.0150.1.7	1,5	3,8	6,7	4	10	28	2,5	7	109140	Δ
R109.0200.1.7	2	3,8	6,7	4	10	28	2,5	7	109140	▲
R109.0100.2.7	1	3,8	6,7	4	15	33	2,5	7	109140	Δ
R109.0150.2.7	1,5	3,8	6,7	4	15	33	2,5	7	109140	▲
R109.0200.2.7	2	3,8	6,7	4	15	33	2,5	7	109140	▲
R109.0100.3.7	1	3,8	6,7	4	20	38	2,5	7	109140	Δ
R109.0150.3.7	1,5	3,8	6,7	4	20	38	2,5	7	109140	Δ
R109.0200.3.7	2	3,8	6,7	4	20	38	2,5	7	109140	Δ
L109.0100.1.7	1	3,8	6,7	4	10	28	2,5	7	109140	Δ
L109.0150.1.7	1,5	3,8	6,7	4	10	28	2,5	7	109140	Δ
L109.0200.1.7	2	3,8	6,7	4	10	28	2,5	7	109140	Δ
L109.0100.2.7	1	3,8	6,7	4	15	33	2,5	7	109140	Δ
L109.0150.2.7	1,5	3,8	6,7	4	15	33	2,5	7	109140	Δ
L109.0200.2.7	2	3,8	6,7	4	15	33	2,5	7	109140	Δ
L109.0100.3.7	1	3,8	6,7	4	20	38	2,5	7	109140	Δ
L109.0200.3.7	2	3,8	6,7	4	20	38	2,5	7	109140	Δ

P	●
M	●
K	●
N	●
S	●
H	-

B

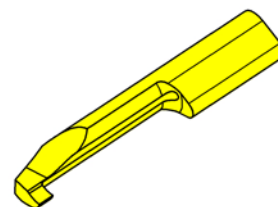
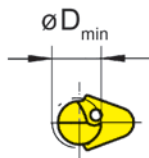
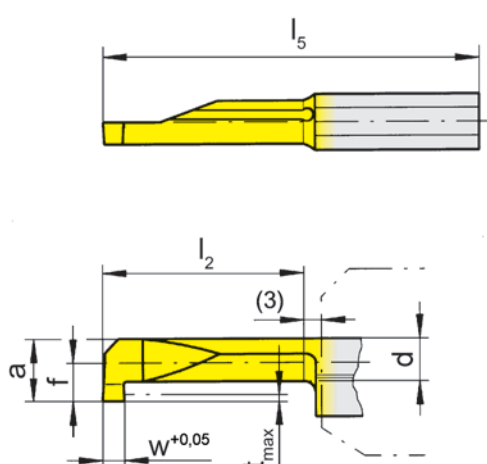
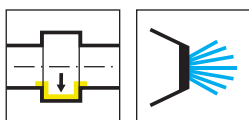

Nuance  
Leghe

R = version à droite représentée  
R = versione destra come in figura

L = version à gauche  
L = versione sinistra a specchio

▲ en stock  
a stock

Δ 4 semaines  
4 settimane

N° de commande Codice prodotto	w	f	a	d	l <sub>2</sub>	l <sub>5</sub>	t <sub>max</sub>	D <sub>min</sub>	HIS	TH35
R109.0150.4.7	1,5	3,8	6,7	4	25	43	2,5	7	109140	Δ
R109.0150.5.7	1,5	3,8	6,7	4	30	48	2,5	7	109140	Δ
R109.0150.6.7	1,5	3,8	6,7	4	35	53	2,5	7	109140	Δ
R109.0200.1.7	2	3,8	6,7	4	10	28	2,5	7	109140	▲
R109.0200.2.7	2	3,8	6,7	4	15	33	2,5	7	109140	▲
R109.0200.3.7	2	3,8	6,7	4	20	38	2,5	7	109140	Δ
R109.0200.4.7	2	3,8	6,7	4	25	43	2,5	7	109140	Δ
R109.0200.5.7	2	3,8	6,7	4	30	48	2,5	7	109140	▲
R109.0200.6.7	2	3,8	6,7	4	35	53	2,5	7	109140	▲
L109.0150.4.7	1,5	3,8	6,7	4	25	43	2,5	7	109140	Δ
L109.0150.5.7	1,5	3,8	6,7	4	30	48	2,5	7	109140	Δ
L109.0150.6.7	1,5	3,8	6,7	4	35	53	2,5	7	109140	Δ
L109.0200.1.7	2	3,8	6,7	4	10	28	2,5	7	109140	Δ
L109.0200.2.7	2	3,8	6,7	4	15	33	2,5	7	109140	Δ
L109.0200.3.7	2	3,8	6,7	4	20	38	2,5	7	109140	Δ
L109.0200.4.7	2	3,8	6,7	4	25	43	2,5	7	109140	Δ
L109.0200.5.7	2	3,8	6,7	4	30	48	2,5	7	109140	Δ
L109.0200.6.7	2	3,8	6,7	4	35	53	2,5	7	109140	Δ

P	●
M	●
K	●
N	●
S	●
H	-

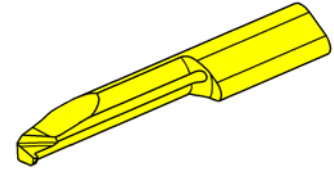
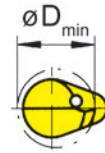
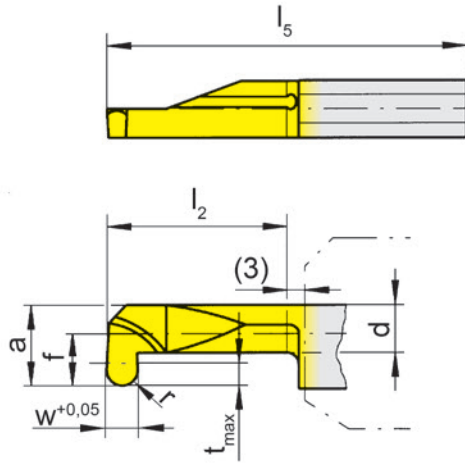
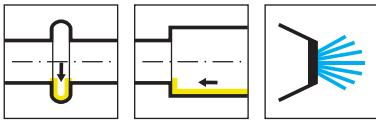

R = version à droite représentée  
R = versione destra come in figura

L = version à gauche  
L = versione sinistra a specchio

▲ en stock  
a stock

Nuance  
Leghe  
Δ 4 semaines  
4 settimane

N° de commande Codice prodotto	w	r	f	a	d	$l_2$	$l_5$	$t_{max}$	$D_{min}$	HIS	TH35
R109.0005.4.6	1	0,5	2,8	5,7	3,7	25	43	1,8	6	109140	Δ
R109.0007.4.6	1,5	0,75	2,8	5,7	3,7	25	43	1,8	6	109140	Δ
R109.0010.4.6	2	1	2,8	5,7	3,7	25	43	1,8	6	109140	Δ
R109.0005.6.7	1	0,5	3,8	6,7	4	35	53	2,5	7	109140	Δ
R109.0007.6.7	1,5	0,75	3,8	6,7	4	35	53	2,5	7	109140	Δ
R109.0010.6.7	2	1	3,8	6,7	4	35	53	2,5	7	109140	▲
L109.0005.4.6	1	0,5	2,8	5,7	3,7	25	43	1,8	6	109140	Δ
L109.0007.4.6	1,5	0,75	2,8	5,7	3,7	25	43	1,8	6	109140	Δ
L109.0010.4.6	2	1	2,8	5,7	3,7	25	43	1,8	6	109140	Δ
L109.0005.6.7	1	0,5	3,8	6,7	4	35	53	2,5	7	109140	Δ
L109.0007.6.7	1,5	0,75	3,8	6,7	4	35	53	2,5	7	109140	Δ
L109.0010.6.7	2	1	3,8	6,7	4	35	53	2,5	7	109140	Δ
											P ●
											M ●
											K ●
											N ●
											S ●
											H -

B

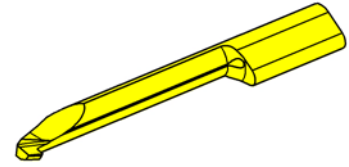
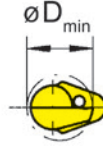
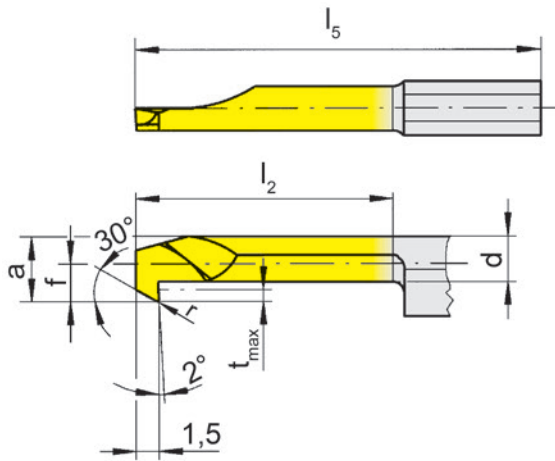
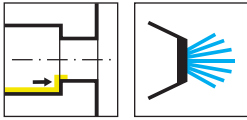

R = version à droite représentée  
R = versione destra come in figura

L = version à gauche  
L = versione sinistra a specchio

▲ en stock  
a stock

Nuance  
Leghe  
Δ 4 semaines  
4 settimane

N° de commande Codice prodotto	r	f	a	d	l <sub>2</sub>	l <sub>5</sub>	t <sub>max</sub>	D <sub>min</sub>	HIS	TH35
R109.3028.3.6	0,2	2,8	5,7	3,7	20	38	1,8	6	109140	Δ
R109.3028.5.6	0,2	2,8	5,7	3,7	30	48	1,8	6	109140	Δ
R109.3038.3.7	0,2	3,8	6,7	4	20	38	2,5	7	109140	▲
R109.3038.5.7	0,2	3,8	6,7	4	30	48	2,5	7	109140	▲
L109.3028.3.6	0,2	2,8	5,7	3,7	20	38	1,8	6	109140	Δ
L109.3028.5.6	0,2	2,8	5,7	3,7	30	48	1,8	6	109140	Δ
L109.3038.3.7	0,2	3,8	6,7	4	20	38	2,5	7	109140	Δ
L109.3038.5.7	0,2	3,8	6,7	4	30	48	2,5	7	109140	Δ
										P ●
										M ●
										K ●
										N ●
										S ●
										H -

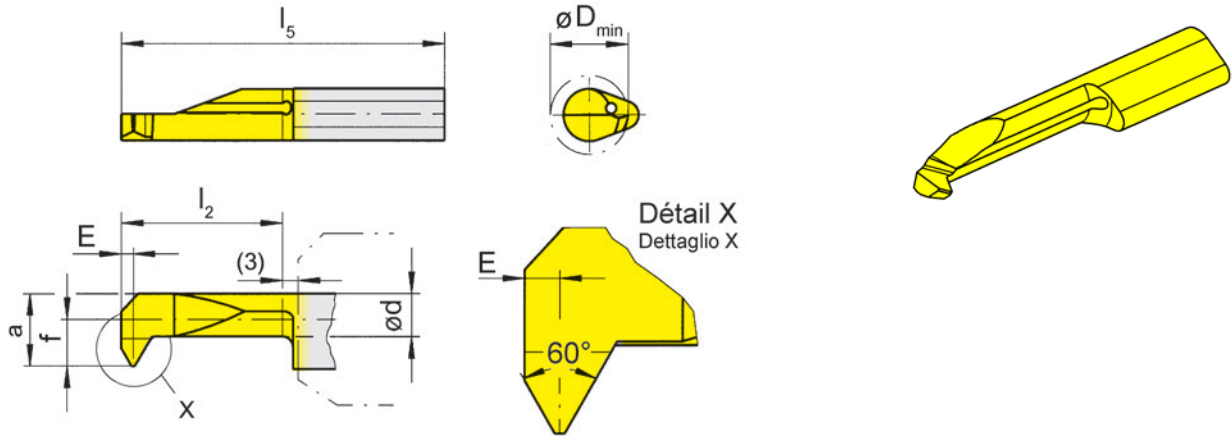
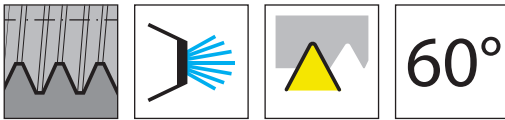

R = version à droite représentée  
R = versione destra come in figura

L = version à gauche  
L = versione sinistra a specchio

▲ en stock  
a stock

Nuance  
Leghe  
Δ 4 semaines  
4 settimane

N° de commande Codice prodotto	P	P <sub>max</sub>	E	f	a	d	l <sub>2</sub>	l <sub>5</sub>	D <sub>min</sub>	HIS	TH35
R109.0815.1.7	1,5	1,75	0,9	3,8	6,7	5,1	10	28	7	109140	Δ
R109.0815.3.7	1,5	1,75	0,9	3,8	6,7	5,1	20	38	7	109140	▲
R109.0815.5.7	1,5	1,75	0,9	3,8	6,7	5,1	30	48	7	109140	▲
L109.0815.1.7	1,5	1,75	0,9	3,8	6,7	5,1	10	28	7	109140	Δ
L109.0815.3.7	1,5	1,75	0,9	3,8	6,7	5,1	20	38	7	109140	Δ
L109.0815.5.7	1,5	1,75	0,9	3,8	6,7	5,1	30	48	7	109140	Δ
											P ●
											M ●
											K ●
											N ●
											S ●
											H -

B

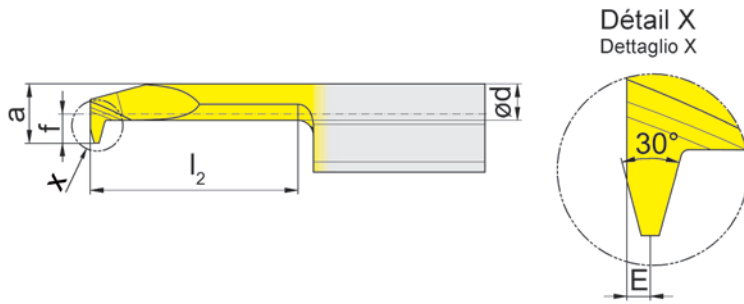
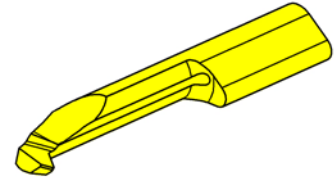
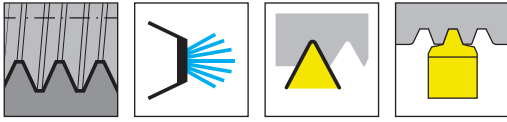

R = version à droite représentée, xxx  
R = versione destra come in figura, xxx

Nuance  
Leghe  
▲ en stock  
a stock  
Δ 4 semaines  
4 settimane

N° de commande Codice prodotto	P	E	f	a	d	$l_2$	$l_5$	$D_{min}$	HIS	TH35
R109.0915.3.6	1,5	0,6	2,8	5,7	3,5	20	38	6	109140	▲
R109.1220.3.6	2	0,8	2,8	5,7	3,5	20	38	6	109140	▲
R109.1220.3.7	2	0,8	3,8	6,7	4,8	20	38	7	109140	▲
R109.1220.5.7	2	0,8	3,8	6,7	4,8	30	48	7	109140	▲
R109.1730.3.7	3	1,2	3,8	6,7	4,3	20	38	7	109140	▲
	P	●								
	M	●								
	K	●								
	N	●								
	S	●								
	H	-								

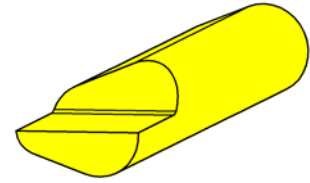
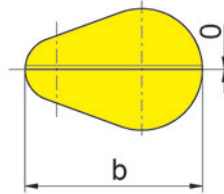
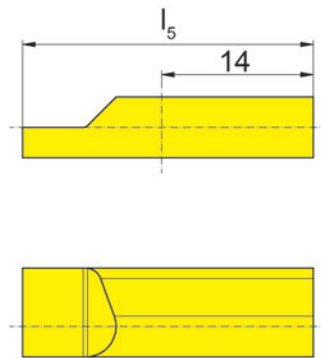
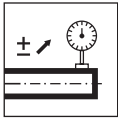

R = version à droite représentée  
R = versione destra come in figura

L = version à gauche  
L = versione sinistra a specchio

N° de commande Codice prodotto	b	$l_5$	HIS
<b>R109.LEHR.H.01</b>	8,5	28	109140
<b>L109.LEHR.H.01</b>	8,5	28	109140

Plaquette pour réglage des porte outils.  
Inserto master per pre-setting

B

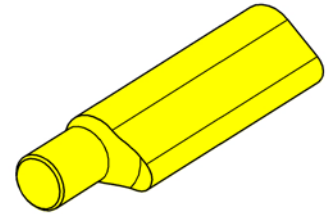
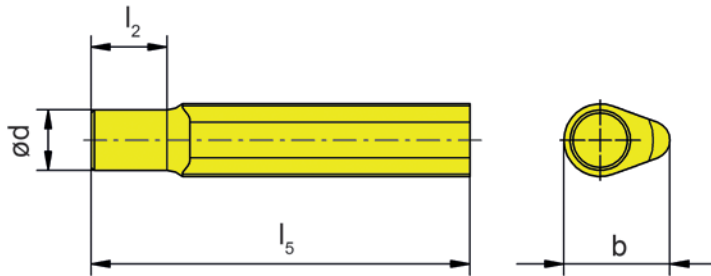
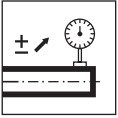

N° de commande	d	b	$l_2$	$l_5$	HIS
Codice prodotto					
<b>109.LEHR.D.01</b>	4,5	8,5	5	25	109140

Plaquette pour réglage des porte outils.  
Inserto master per pre-setting

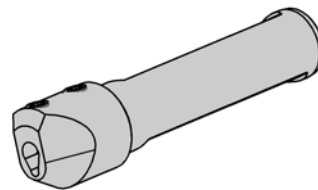
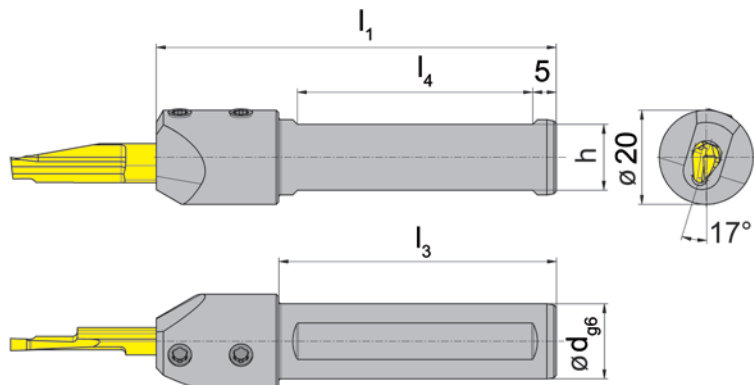
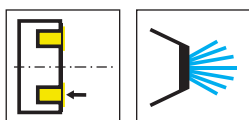

R = version à droite représentée  
R = versione destra come in figura

L = version à gauche  
L = versione sinistra a specchio

N° de commande Codice prodotto	d	l <sub>1</sub>	l <sub>3</sub>	h	l <sub>4</sub>	HWS
RB109.0016.14.2	16	85	59	14	50	109240
LB109.0016.14.2	16	85	59	14	50	109240

### Pièces Détachées

Ricambi

Porte outils Portainsero	Vis de serrage Vite di serraggio	Tournevis TORX PLUS® Cacciavite TORX PLUS®
R/LB109.0016.14.2	6.075T15P	T15PQ

B

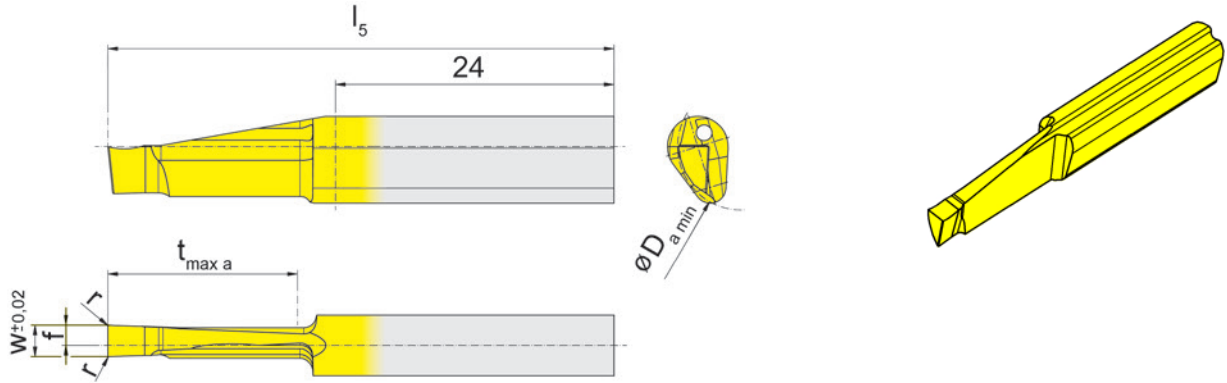
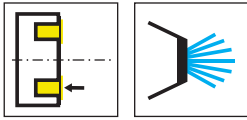

L = version à gauche représentée  
L = versione sinistra come in figura

R = version à droite  
R = versione destra a specchio

▲ en stock  
a stock

Nuance  
Leghe  
Δ 4 semaines  
4 settimane

N° de commande Codice prodotto	w	r	f	$l_5$	$t_{max a}$	$D_{a min}$	HIS		TI25
RA109.1520.3.2	2	0,1	1	48	20	15	109240	▲	●
RA109.1525.3.2	2,5	0,1	1,2	48	20	15	109240	▲	●
RA109.1530.3.2	3	0,1	1,5	48	20	15	109240	▲	●
LA109.1520.3.2	2	0,1	1	48	20	15	109240	Δ	●
LA109.1525.3.2	2,5	0,1	1,2	48	20	15	109240	Δ	●
LA109.1530.3.2	3	0,1	1,5	48	20	15	109240	▲	●

Gorge frontale sur toute la profondeur possible uniquement  $D_{a min}$  15 - 40 mm!  
Gole frontali con larghezza e profondità max, sono solo possibili se tra  $D_{a min}$  15 - 40 mm!

P	●
M	●
K	●
N	●
S	●
H	-

**110**

**C**



**Porte outils et plaquettes**

**Portainsero e inserti**

C

Porte outils  
Portainsero  
B110/B110TS/B110C/  
VDI/WFB.110

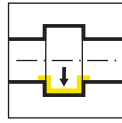

Page/Pag.  
178-183, 185

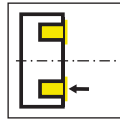

Page/Pag.  
194

Supports réglables  
Portainsero registrabile  
N

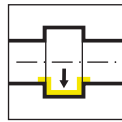

Page/Pag.  
184

Plaque de coupe  
Inserto  
110/A110

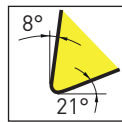

Page/Pag.  
186

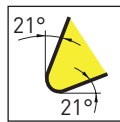

Page/Pag.  
187

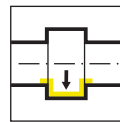

Page/Pag.  
188-189

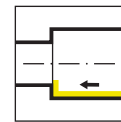

Page/Pag.  
190

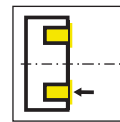

Page/Pag.  
195-196

Plaque  
Inserto  
110

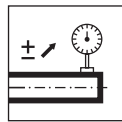

Page/Pag.  
191-192

Dimensions de base  
Dimensioni di base

Page/Pag.  
193

Ø Alésage Foro Ø	Type de produit / Linea di prodotto											
	105	109	110	106	107	108	10P	111	11P	114	116	18P
≥ 0,2	•											
≥ 0,5	•											
≥ 0,7	•											
≥ 1,0	•											
≥ 1,5	•											
≥ 2,0	•											
≥ 3,0	•											
≥ 4,0	•											
≥ 5,0	•											
≥ 6,0	•	•	•	•								
≥ 6,8		•	•	•								
≥ 7,0		•			•							
≥ 7,8			•		•	•						
≥ 8,0			•		•	•						
≥ 9,0			•		•	•	•					
≥ 10,0			•				•	•	•			
≥ 10,5									•			
≥ 11,0								•	•			
≥ 11,5									•			
≥ 13,8										•		
≥ 14,0										•	•	
≥ 16,0											•	
≥ 16,5										(•)		
≥ 18,0												•
Profondeur de gorge Profondità della gola	2,5	2,5	4,0	0,8	2,0	1,0	3,0	2,3	3,5	4,0 (6,5)	4,3	8,0
Largeur de gorge Larghezza della gola	0,5- 2,0	1,0- 2,0	1,0- 3,0	0,7- 1,5	1,0- 2,0	0,7- 2,0	1,0- 3,0	0,7- 3,0	1,0- 3,0	0,7- 3,0	0,7- 4,0	2,0- 3,0
Type d'usinage / Operazione												
Gorge Gole	•	•	•	•	•	•	•	•	•	•	•	•
Alésage Alesatura	•	•	•	•	•	•		•		•	•	
Filetage Filettatura	•	•			•	•		•		•	•	
Chanfreinage Smussatura	•	•			•	•		•		•	•	
Gorge frontale Gole assiali	•	•	•							•		
Tournage dur Alesatura e profilatura	•											



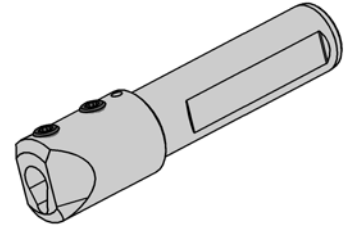
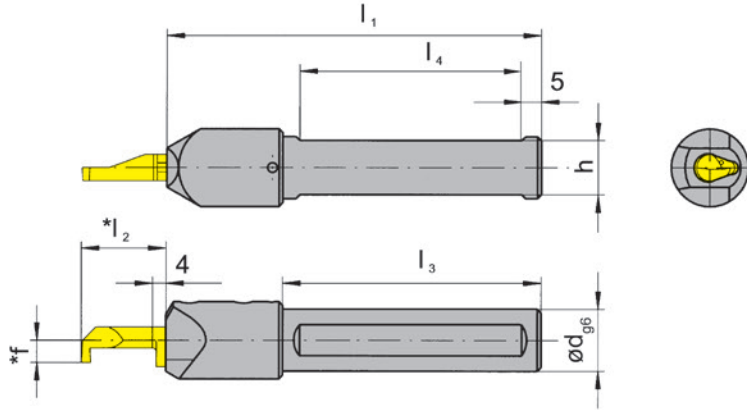
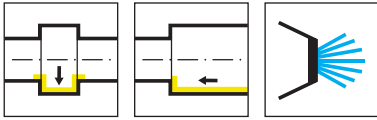

Illustration de coupe à droite représentée  
Figura = taglio destro

Numéro de commande Codice prodotto	d	l <sub>1</sub>	l <sub>3</sub>	h	l <sub>4</sub>	HWS
B110.0016.02	16	100	70	14	55	110260
B110.0020.02	20	100	-	18	55	110260
B110.0022.02	22	100	-	20	55	110260
B110.0025.02	25	100	-	23	55	110260

f, l2 voir plaquette type 110  
f, l2 vd. inserto tipo 110

### Pièces Détachées

Ricambi

Porte outils Portainsero	Vis de serrage Vite di serraggio	Tournevis TORX PLUS® Cacciavite TORX PLUS®
B110...	6.075T15P	T15PQ

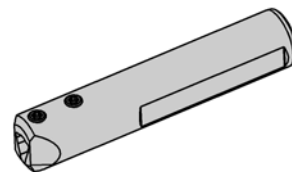
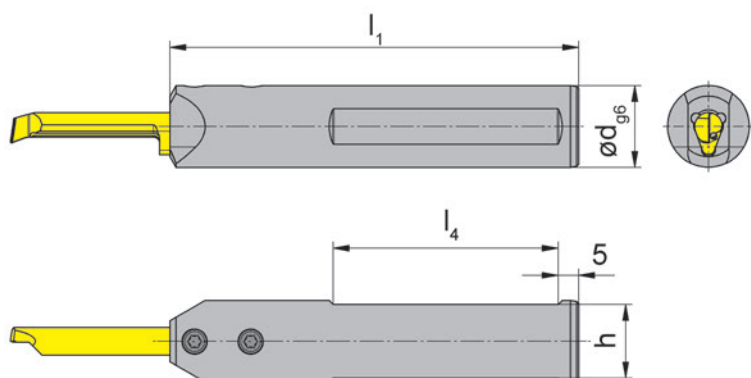
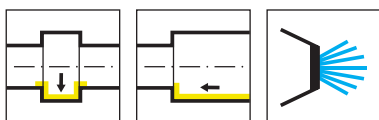

Illustration de coupe à droite représentée  
Figura = taglio destro

Numéro de commande Codice prodotto	d	l <sub>1</sub>	h	l <sub>4</sub>	HWS
<b>B110.0020.K.02</b>	20	100	18	55	110260

### Pièces Détachées

Ricambi

Porte outils Portainsero	Vis de serrage Vite di serraggio	Tournevis TORX PLUS® Cacciavite TORX PLUS®
B110.0020.K.02	<b>6.075T15P</b>	<b>T15PQ</b>

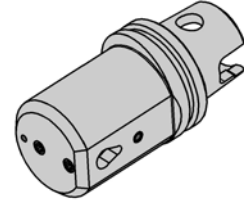
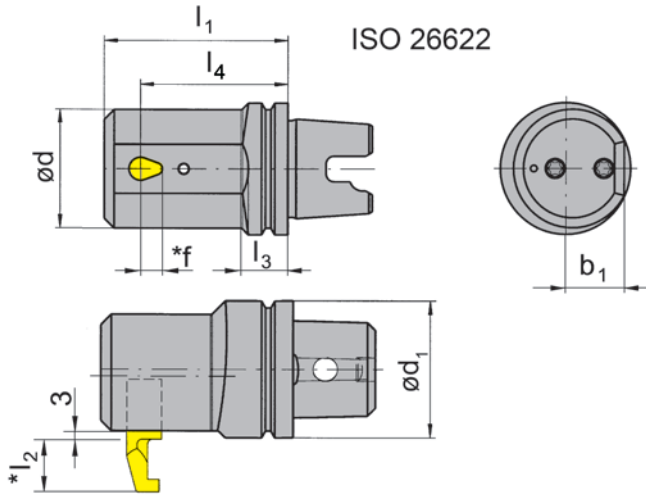
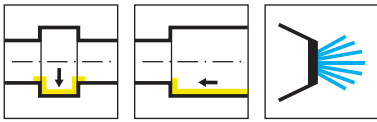

R = version à droite représentée  
R = versione destra come in figura

Numéro de commande Codice prodotto	d <sub>1</sub>	l <sub>3</sub>	d	l <sub>1</sub>	l <sub>4</sub>	b <sub>1</sub>	Type de machine Tipo macchina	HWS
<b>RB110.TS40.2.2.02</b>	40	14	36	56	45	18	INDEX MS32	110260

f, l2 voir plaquette type 110  
f, l2 vd. inserto tipo 110

pour système INDEX Multi broche  
Sistema per plurimandrino INDEX

### Pièces Détachées

Ricambi

Porte outils Portainsero	Vis de serrage Vite di serraggio	Tournevis TORX PLUS® Cacciavite TORX PLUS®
RB110.TS40.2.2.02	<b>6.075T15P</b>	<b>T15PQ</b>

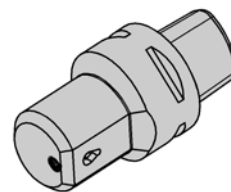
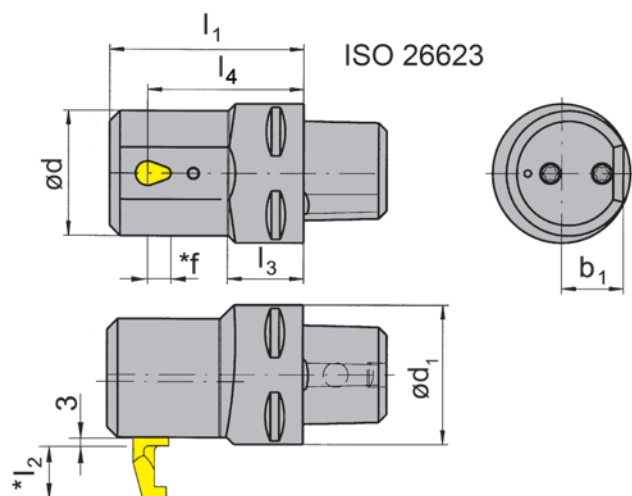
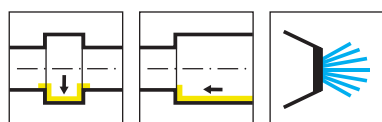

R = version à droite représentée

R = versione destra come in figura

Numéro de commande Codice prodotto	d <sub>1</sub>	l <sub>3</sub>	d	l <sub>1</sub>	l <sub>4</sub>	b <sub>1</sub>	HWS
<b>RB110.00C3.2.2.02</b>	32	15	36	56	45	18	110260
<b>RB110.00C4.2.2.02</b>	40	22	36	56	45	18	110260

f, l<sub>2</sub> voir plaquette type 110

f, l<sub>2</sub> vd. inserto tipo 110

pour système INDEX Multi broche

Sistema per plurimandrino INDEX

### Pièces Détachées

Ricambi

Porte outils Portainsero	Vis de serrage Vite di serraggio	Tournevis TORX PLUS® Cacciavite TORX PLUS®
RB110...	<b>6.075T15P</b>	<b>T15PQ</b>

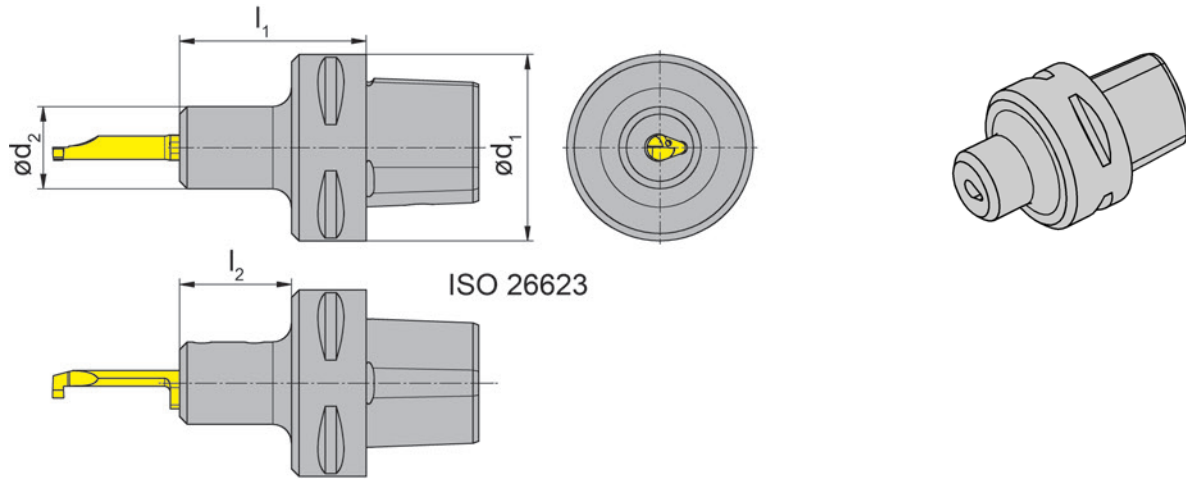
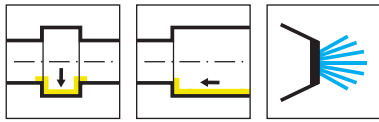

R = version à droite représentée  
R = versione destra come in figura

L = version à gauche  
L = versione sinistra a specchio

Numéro de commande Codice prodotto	d <sub>1</sub>	d <sub>2</sub>	l <sub>1</sub>	l <sub>2</sub>	HWS
RB110.00C3.22.1.02	32	22	45	30	110260
RB110.00C4.22.1.02	40	22	50	30	110260
RB110.00C5.22.1.02	50	22	50	30	110260
RB110.00C6.22.1.02	63	22	52	30	110260
LB110.00C3.22.1.02	32	22	45	30	110260
LB110.00C4.22.1.02	40	22	50	30	110260
LB110.00C5.22.1.02	50	22	50	30	110260
LB110.00C6.22.1.02	63	22	52	30	110260

Pièces Détachées

Ricambi

Porte outils Portainsero	Vis de serrage Vite di serraggio	Tournevis TORX PLUS® Cacciavite TORX PLUS®
R/LB110...	6.075T15P	T15PQ

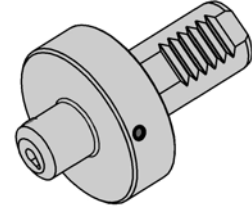
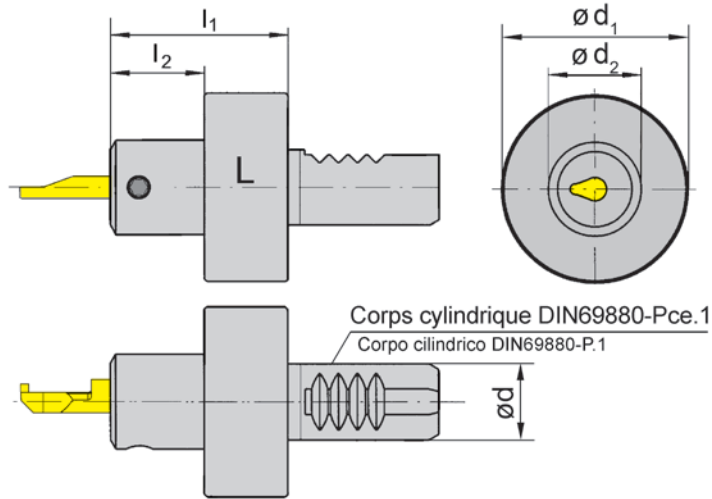
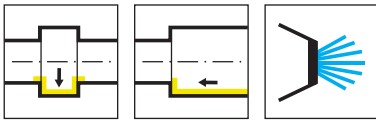

L = version à gauche représentée  
L = versione sinistra come in figura

R = version à droite  
R = versione destra a specchio

Numéro de commande Codice prodotto	d	l <sub>1</sub>	l <sub>2</sub>	d <sub>2</sub>	d <sub>1</sub>	HWS
VDI16.L110.30.02	16	48	30	22	40	110260
VDI16.R110.30.02	16	48	30	22	40	110260
VDI20.R110.30.02	20	48	30	22	50	110260
VDI25.L110.30.02	25	48	30	22	58	110260
VDI25.R110.30.02	25	48	30	22	58	110260
VDI30.L110.30.02	30	48	30	22	68	110260
VDI30.R110.30.02	30	48	30	22	68	110260
VDI40.L110.30.02	40	48	30	22	83	110260
VDI40.R110.30.02	40	48	30	22	83	110260

### Pièces Détachées

Ricambi

Porte outils Portainsero	Vis de serrage Vite di serraggio	Tournevis TORX PLUS® Cacciavite TORX PLUS®
VDI16...	6.075T15P	T15PQ

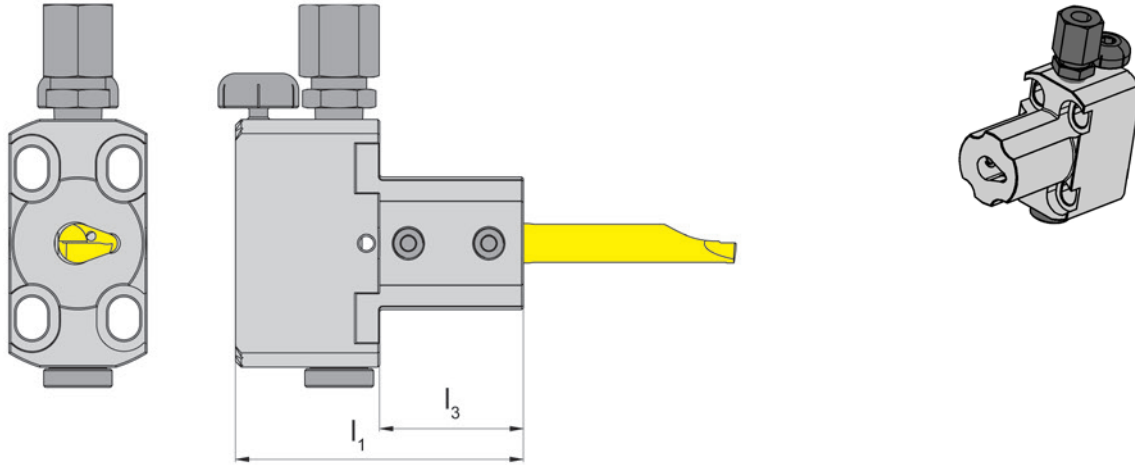
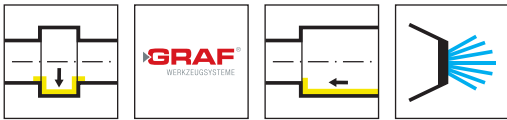

Illustration de coupe à droite représentée  
Figura = taglio destro

Numéro de commande Codice prodotto	$l_1$	$l_3$	HWS
<b>N.79.IK</b>	50	25	110260

Le raccord du liquide de coupe ne fait pas partie de la référence . Merci de le commander séparément.  
L'adduttore del refrigerante va ordinato separatamente!

**Pièces Détachées**

Ricambi

Supports réglables Portainsero registrabile	Vis de serrage Vite di serraggio	Arrosage Lubrificazione
N.79.IK	<b>6.075T15P</b>	<b>004.00.19</b>

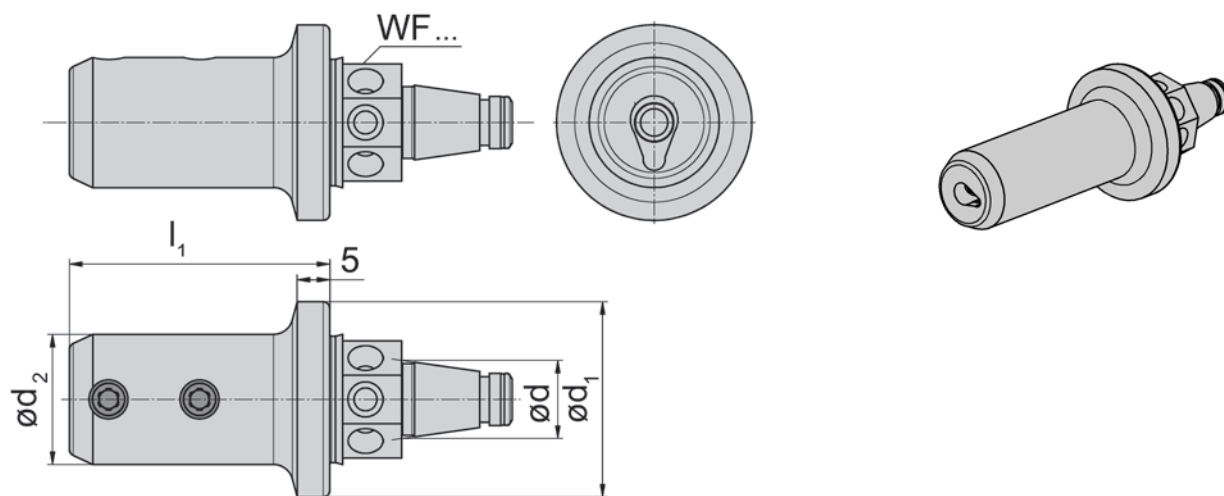
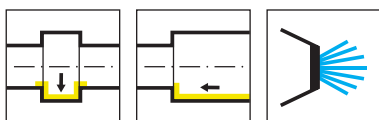

Numéro de commande Codice prodotto	d <sub>1</sub>	l <sub>1</sub>	d	d <sub>2</sub>	HWS	HMS
WFB.2HO.110	30	40	12	20	110260	WFB
WFB.3HO.110	50	40	20	20	110260	WFB

### Pièces Détachées

Ricambi

Porte outils Portainsero	Vis de serrage Vite di serraggio	Tournevis TORX PLUS® Cacciavite TORX PLUS®
WFB...	6.075T15P	T15PQ

# Plaquette de coupe

## Inserto

# 110

$\emptyset \geq 6 \text{ mm}$

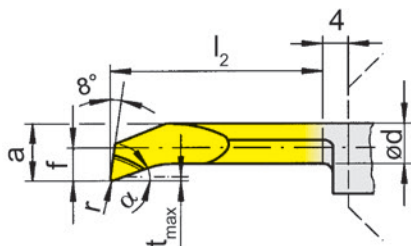
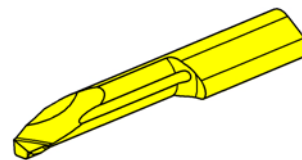
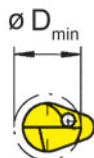
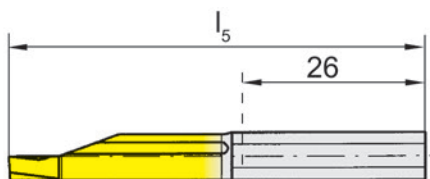
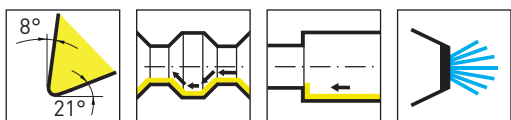

C

R = version à droite représentée  
R = versione destra come in figura

L = version à gauche  
L = versione sinistra a specchio

▲ en stock  
a stock

Nuance  
Leghe  
Δ 4 semaines  
4 settimane

Numéro de commande Codice prodotto	r	f	a	d	l <sub>2</sub>	l <sub>5</sub>	t <sub>max</sub>	D <sub>min</sub>	α	HIS	Nuance Leghe		
											EG35	TH35	TI25
R110.1829.7.6	0,2	2,9	5,7	4,8	40	70	0,5	6	21°	110260	▲	▲	▲
R110.1829.9.6	0,2	2,9	5,7	4,8	50	80	0,5	6	21°	110260	▲	▲	▲
R110.1829.9.8	0,2	4	7,4	6	50	80	0,5	8	21°	110260	▲	▲	▲
L110.1829.7.6	0,2	2,9	5,7	4,8	40	70	0,5	6	21°	110260	▲	▲	▲
L110.1829.9.6	0,2	2,9	5,7	4,8	50	80	0,5	6	21°	110260	▲	▲	▲
L110.1829.9.8	0,2	4	7,4	6	50	80	0,5	8	21°	110260	▲	▲	▲
P	●	●	●										
M	●	●	●										
K	○	●	●										
N	-	●	●										
S	-	●	●										
H	-	-	-										

# Plaquette de coupe Inserto

# 110

$\varnothing \geq 6 \text{ mm}$

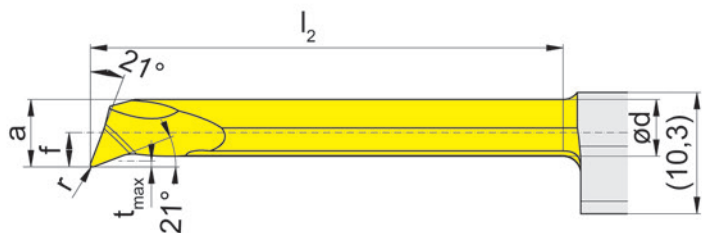
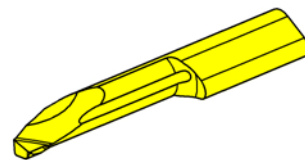
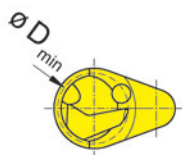
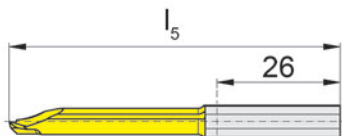
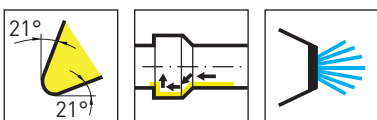

R = version à droite représentée  
R = versione destra come in figura

L = version à gauche  
L = versione sinistra a specchio

▲ en stock  
a stock

Nuance  
Leghe  
Δ 4 semaines  
4 settimane

Numéro de commande Codice prodotto	r	f	a	d	l <sub>2</sub>	l <sub>5</sub>	t <sub>max</sub>	D <sub>min</sub>	HIS	EG35
R110.2129.7.6	0,2	2,9	5,7	4,8	40	70	0,5	6	110260	Δ
R110.2129.9.6	0,2	2,9	5,7	4,8	50	80	0,5	6	110260	Δ
R110.2140.7.8	0,2	4	7,4	6	40	70	0,5	8	110260	Δ
R110.2140.9.8	0,2	4	7,4	6	50	80	0,5	8	110260	Δ
L110.2129.7.6	0,2	2,9	5,7	4,8	40	70	0,5	6	110260	Δ
L110.2129.9.6	0,2	2,9	5,7	4,8	50	80	0,5	6	110260	Δ
L110.2140.7.8	0,2	4	7,4	6	40	70	0,5	8	110260	Δ
L110.2140.9.8	0,2	4	7,4	6	50	80	0,5	8	110260	Δ
										P ●
										M ●
										K ○
										N -
										S -
										H -



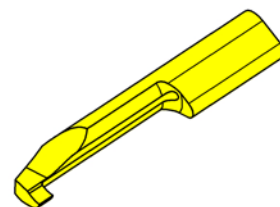
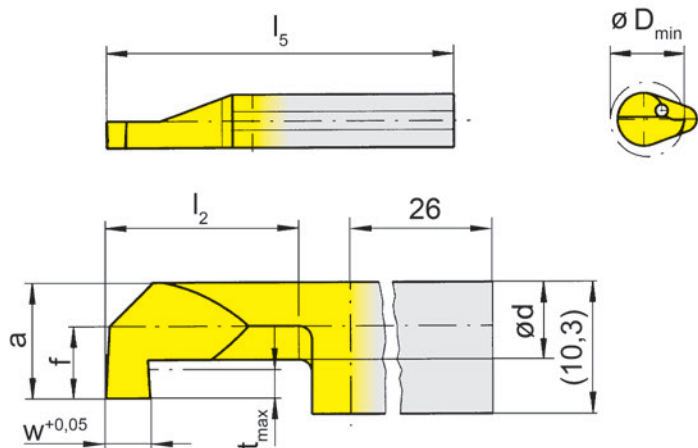
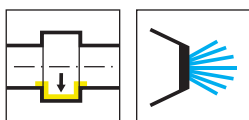

C

R = version à droite représentée  
R = versione destra come in figura

L = version à gauche  
L = versione sinistra a specchio

▲ en stock  
a stock

Nuance  
Leghe  
Δ 4 semaines  
4 settimane

Numéro de commande Codice prodotto	w	f	a	d	l <sub>2</sub>	l <sub>5</sub>	t <sub>max</sub>	D <sub>min</sub>	HIS	Nuance	
										EG35	TN35
R110.0100.5.8	1	4	7,4	4,2	30	60	2,8	8	110260	▲	▲
R110.0200.5.8	2	4	7,4	4,2	30	60	2,8	8	110260	▲	▲
R110.0250.5.8	2,5	4	7,4	4,2	30	60	2,8	8	110260	▲	▲
R110.0100.7.8	1	4	7,4	4,2	40	70	2,8	8	110260	▲	▲
R110.0200.7.8	2	4	7,4	4,2	40	70	2,8	8	110260	▲	▲
R110.0250.7.8	2,5	4	7,4	4,2	40	70	2,8	8	110260	▲	▲
R110.0100.5.0	1	6	9,4	5	30	60	4	10	110260	▲	▲
R110.0200.5.0	2	6	9,4	5	30	60	4	10	110260	▲	▲
R110.0300.5.0	3	6	9,4	5	30	60	4	10	110260	▲	▲
R110.0100.9.0	1	6	9,4	5	50	80	4	10	110260	Δ	▲
R110.0200.9.0	2	6	9,4	5	50	80	4	10	110260	▲	▲
R110.0300.9.0	3	6	9,4	5	50	80	4	10	110260	▲	▲
L110.0100.5.8	1	4	7,4	4,2	30	60	2,8	8	110260	▲	▲
L110.0200.5.8	2	4	7,4	4,2	30	60	2,8	8	110260	▲	▲
L110.0250.5.8	2,5	4	7,4	4,2	30	60	2,8	8	110260	▲	▲
L110.0100.7.8	1	4	7,4	4,2	40	70	2,8	8	110260	Δ	▲
L110.0200.7.8	2	4	7,4	4,2	40	70	2,8	8	110260	▲	▲
L110.0250.7.8	2,5	4	7,4	4,2	40	70	2,8	8	110260	Δ	▲
L110.0100.5.0	1	6	9,4	5	30	60	4	10	110260	▲	▲
L110.0200.5.0	2	6	9,4	5	30	60	4	10	110260	▲	▲
L110.0300.5.0	3	6	9,4	5	30	60	4	10	110260	▲	▲
L110.0100.9.0	1	6	9,4	5	50	80	4	10	110260	Δ	Δ
L110.0200.9.0	2	6	9,4	5	50	80	4	10	110260	Δ	▲
L110.0300.9.0	3	6	9,4	5	50	80	4	10	110260	Δ	Δ
P	●	●									
M	●	●									
K	○	●									
N	-	●									
S	-	●									
H	-	-									

# Plaquette de coupe

## Inserto

# 110

$\varnothing \geq 8 \text{ mm}$

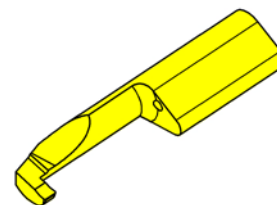
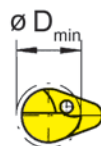
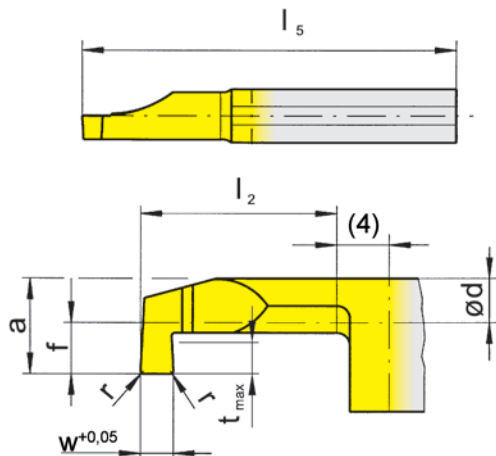
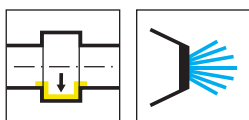

Nuance  
Leghe

▲ en stock  
a stock

Δ 4 semaines  
4 settimane

R = version à droite représentée  
R = versione destra come in figura

Numéro de commande Codice prodotto	w	r	f	a	d	l <sub>2</sub>	l <sub>5</sub>	t <sub>max</sub>	D <sub>min</sub>	HIS	Nuance	
											EG35	TN35
<b>R110.0200.02.3.8</b>	2	0,2	4	7,4	4,2	20	50	2,8	8	110260	▲	▲
											P	●
											M	●
											K	●
											N	-
											S	-
											H	-

# Plaquette de coupe

## Inserto

# 110

$\varnothing \geq 6 \text{ mm}$

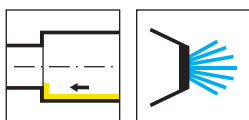

C

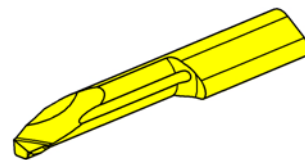
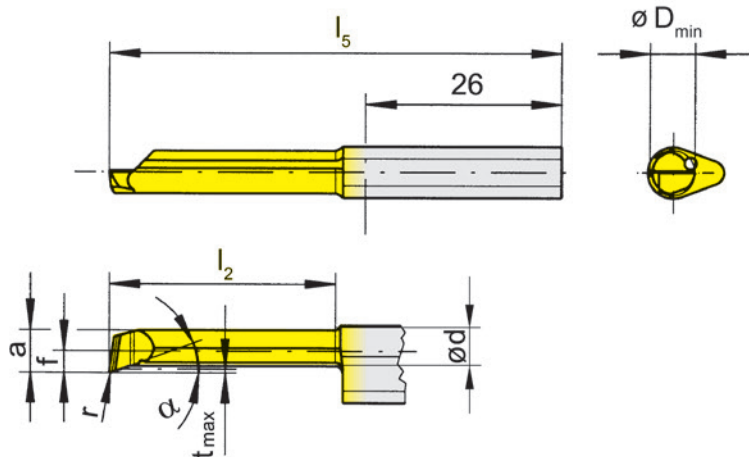

R = version à droite représentée  
R = versione destra come in figura

▲ en stock  
a stock

Nuance  
Leghe  
Δ 4 semaines  
4 settimane

Numéro de commande Codice prodotto	r	f	a	d	l <sub>2</sub>	l <sub>5</sub>	t <sub>max</sub>	D <sub>min</sub>	α	HIS	Nuance Leghe	
											EG35	TI25
R110.1829.9.H6	0,2	2,9	5,7	4,8	50	80	0,5	6	20°	110260	▲	▲
R110.1829.9.H8	0,2	4	7,4	6	50	80	0,5	8	20°	110260	▲	▲
											P	●
											M	●
											K	●
											N	-
											S	-
											H	-

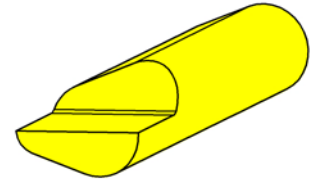
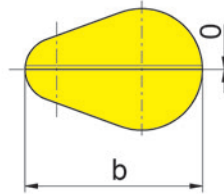
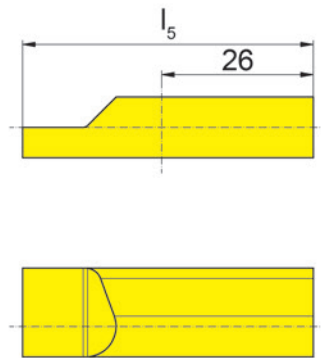
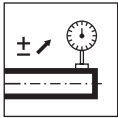

R = version à droite représentée  
R = versione destra come in figura

L = version à gauche  
L = versione sinistra a specchio

Numéro de commande Codice prodotto	b	$l_5$	HIS
<b>R110.LEHR.H02</b>	10,3	40	110140
<b>L110.LEHR.H02</b>	10,3	40	110140

Plaquette pour réglage des porte outils.  
Inserto master per pre-setting

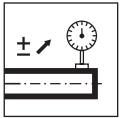

C

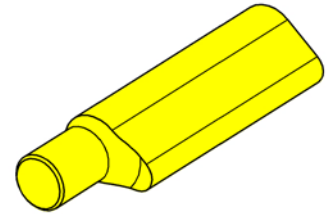
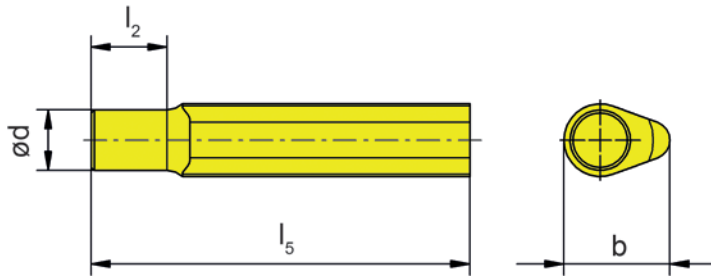

Numéro de commande Codice prodotto	d	b	l <sub>2</sub>	l <sub>5</sub>	HIS
110.LEHR.D.01	5	10,3	5	25	110140

Plaquette pour réglage des porte outils.  
Inserto master per pre-setting

# Dimensions de base

## Dimensioni di base

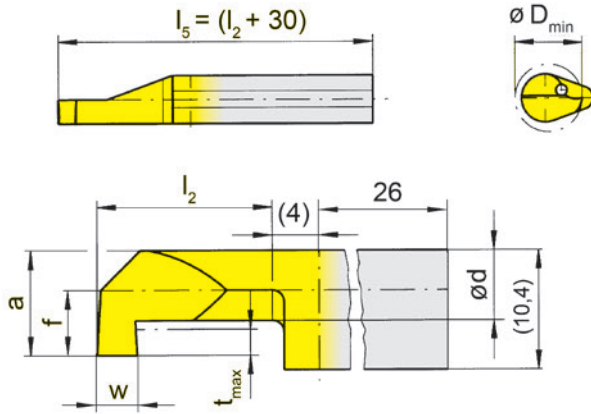
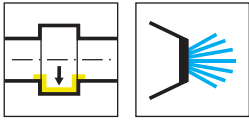

N° de commande Codice prodotto	f	a	d	t <sub>max</sub>	D <sub>min</sub>	w	l <sub>2</sub>	Code longueur Codice lunghezza	MG12	TN35	TI25	TH35
110...8	4	7,4	4,2	2,8	8	0,5-3,0	10	1	<b>Sur demande Su richiesta</b>			
							15	2				
							20	3				
							25	4				
							30	5				
110...9	5	8,4	4,8	3,5	9	35	6					
110...0	6	9,4	5,2	4,0	10	40	7					

Exemple de commande: **R110.0160.3.9<sup>+0,05</sup> r 0,2 (Nuance / Lega)**

Esempio d'ordine:

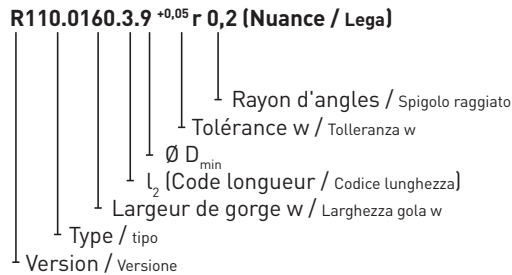

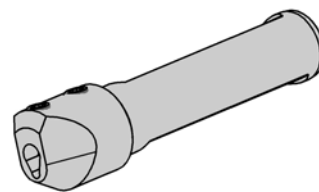
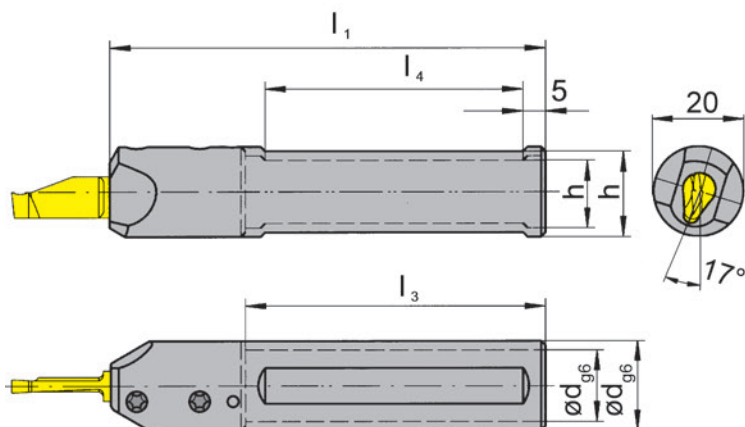
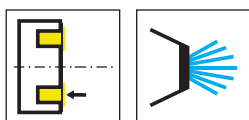

R = version à droite représentée  
R = versione destra come in figura

L = version à gauche  
L = versione sinistra a specchio

Numéro de commande Codice prodotto	d	l <sub>1</sub>	l <sub>3</sub>	h	l <sub>4</sub>	HWS
RB110.0016.16.2	16	100	70	14	55	110260
RB110.0020.16.2	20	100	-	18	55	110260
LB110.0016.16.2	16	100	70	14	55	110260
LB110.0020.16.2	20	100	-	18	55	110260

### Pièces Détachées

Ricambi

Porte outils Portainsero	Vis de serrage Vite di serraggio	Tournevis TORX PLUS® Cacciavite TORX PLUS®
R/LB110...	6.075T15P	T15PQ

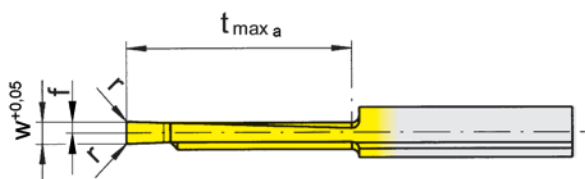
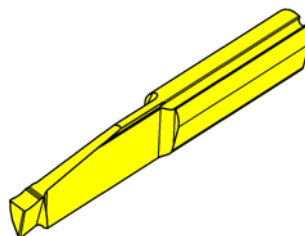
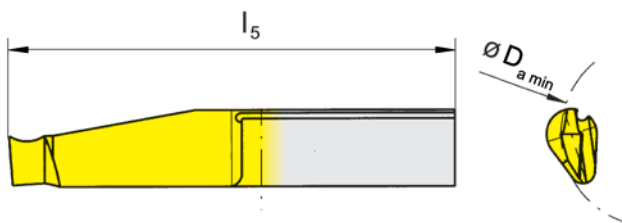
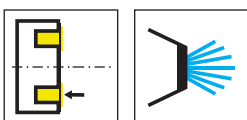

L = version à gauche représentée  
L = versione sinistra come in figura

R = version à droite  
R = versione destra a specchio

▲ en stock  
a stock

Nuance  
Leghe  
Δ 4 semaines  
4 settimane

Numéro de commande Codice prodotto	w	r	f	l <sub>5</sub>	t <sub>max a</sub>	D <sub>a min</sub>	HIS	Nuance Leghe				
								EG35	TH35	TI25	TN35	
RA110.2030.3.0	3	0,2	1,5	50	20	20	110260	▲	▲	▲	▲	
RA110.2030.5.0	3	0,2	1,5	60	30	20	110260	▲	▲	▲	▲	
RA110.5030.3.0	3	0,2	1,5	50	20	50	110260	▲	▲	▲	▲	
RA110.5030.5.0	3	0,2	1,5	60	30	50	110260	▲	▲	▲	▲	
LA110.2030.3.0	3	0,2	1,5	50	20	20	110260	▲	▲	▲	▲	
LA110.2030.5.0	3	0,2	1,5	60	30	20	110260	▲	▲	▲	▲	
LA110.5030.3.0	3	0,2	1,5	50	20	50	110260	▲	▲	▲	▲	
LA110.5030.5.0	3	0,2	1,5	60	30	50	110260	▲	▲	▲	▲	
								P	●	●	●	●
								M	●	●	●	●
								K	○	●	●	●
								N	-	●	●	●
								S	-	●	●	●
								H	-	-	-	-

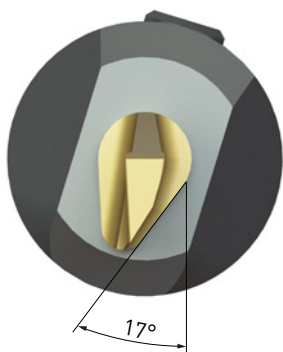

RA110 → RB110

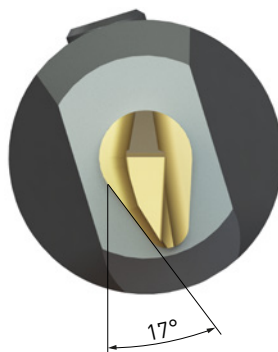

LA110 → LB110

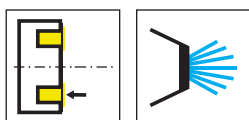

C

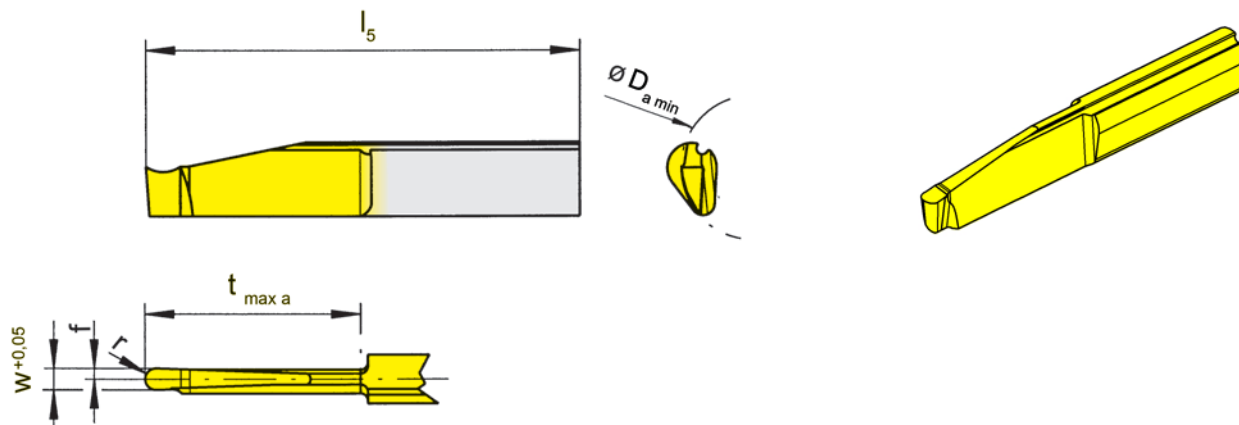

L = version à gauche représentée  
L = versione sinistra come in figura

R = version à droite  
R = versione destra a specchio

▲ en stock  
a stock

Nuance  
Leghe  
Δ 4 semaines  
4 settimane

Numéro de commande Codice prodotto	w	r	f	l <sub>5</sub>	t <sub>max a</sub>	D <sub>a min</sub>	HIS	Nuance Leghe	
								EG35	TN35
RA110.2030.15.5.0	3	1,5	1,5	60	30	20	110260	▲	▲
LA110.2030.15.5.0	3	1,5	1,5	60	30	20	110260	▲	▲
								P	● ●
								M	● ●
								K	○ ●
								N	- ●
								S	- ●
								H	- -

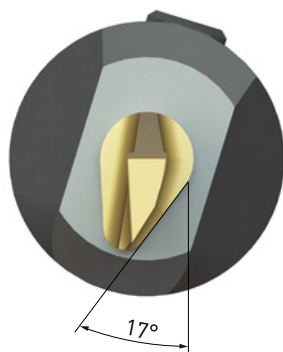

RA110 → RB110

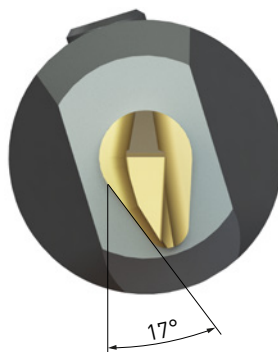

LA110 → LB110

**106**

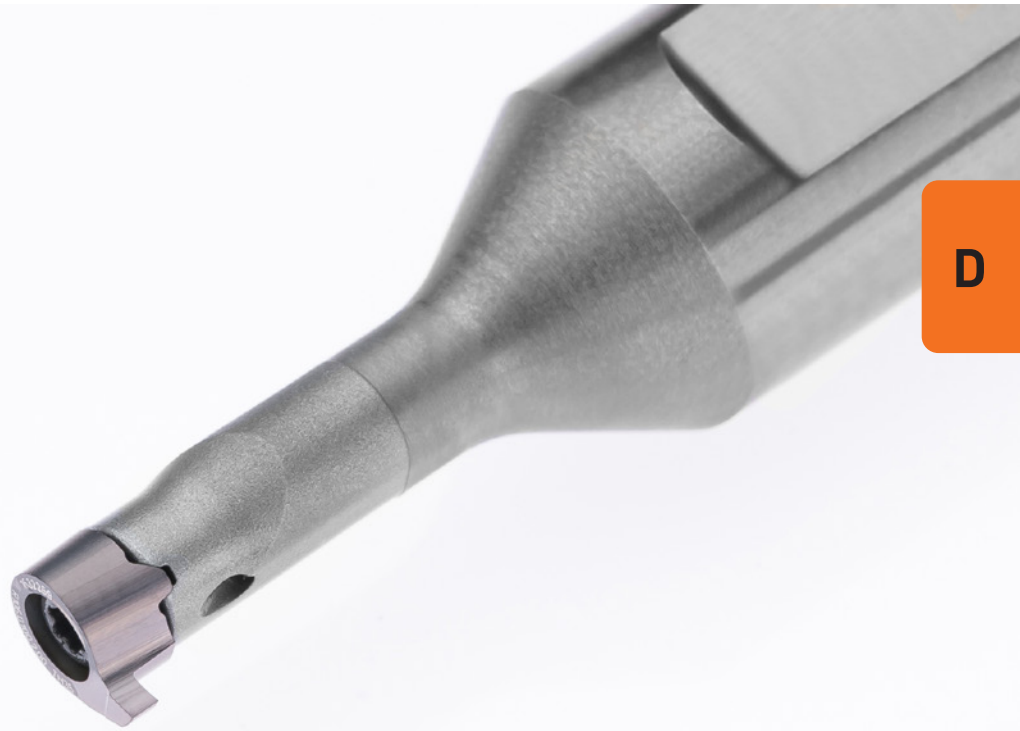

**Porte outils et plaquettes**

**Portainsero e inserti**

Porte outils  
Portainsero  
B106

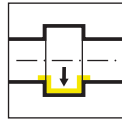

Page/Pag.  
200

Plaquette de coupe  
Inserto  
106

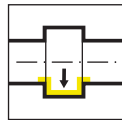

Page/Pag.  
201

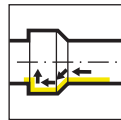

Page/Pag.  
202

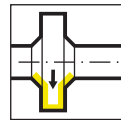

Page/Pag.  
203

D

Ø Alésage Foro Ø	Type de produit / Linea di prodotto											
	105	109	110	106	107	108	10P	111	11P	114	116	18P
≥ 0,2	•											
≥ 0,5	•											
≥ 0,7	•											
≥ 1,0	•											
≥ 1,5	•											
≥ 2,0	•											
≥ 3,0	•											
≥ 4,0	•											
≥ 5,0	•											
≥ 6,0	•	•	•	•								
≥ 6,8		•	•	•								
≥ 7,0		•			•							
≥ 7,8			•		•	•						
≥ 8,0			•		•	•						
≥ 9,0			•		•	•	•					
≥ 10,0			•				•	•	•			
≥ 10,5									•			
≥ 11,0								•	•			
≥ 11,5									•			
≥ 13,8										•		
≥ 14,0										•	•	
≥ 16,0											•	
≥ 16,5										{•}		
≥ 18,0												•
Profondeur de gorge Profondità della gola	2,5	2,5	4,0	0,8	2,0	1,0	3,0	2,3	3,5	4,0 (6,5)	4,3	8,0
Largeur de gorge Larghezza della gola	0,5- 2,0	1,0- 2,0	1,0- 3,0	0,7- 1,5	1,0- 2,0	0,7- 2,0	1,0- 3,0	0,7- 3,0	1,0- 3,0	0,7- 3,0	0,7- 4,0	2,0- 3,0
Usinage / Operazione												
Gorge Gole	•	•	•	•	•	•	•	•	•	•	•	•
Alésage Alesatura	•	•	•	•	•	•			•	•	•	
Filetage Filettatura	•	•			•	•		•		•	•	
Chanfreinage Smussatura	•	•			•	•		•		•	•	
Gorge frontale Gole assiali	•	•	•							•		
Alésage et Profil Alesatura e Profilatura	•											

D

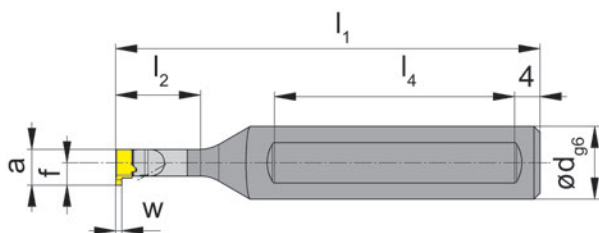
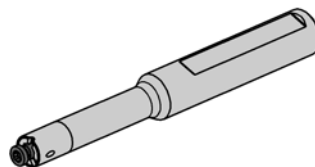
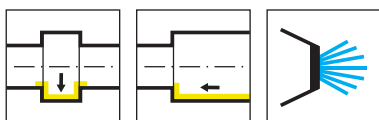

R = version à droite représentée  
R = versione destra come in figura

L = version à gauche  
L = versione sinistra a specchio

Numéro de commande Codice prodotto	d	l <sub>1</sub>	l <sub>2</sub>	h	l <sub>4</sub>	HWS
RB106.0012.01	12	70	14	11	40	106044R
RB106.0012.02	12	80	20	11	40	106044R
RB106.0012.03	12	90	26	11	45	106044R
LB106.0012.01	12	70	14	11	40	106044L
LB106.0012.02	12	80	20	11	40	106044L
LB106.0012.03	12	90	26	11	45	106044L

w, a, tmax et f voir plaquettes  
w, a, tmax, f vd. Inserti

### Pièces Détachées

Ricambi

Porte outils Portainsero	Vis de serrage Vite di serraggio	Tournevis TORX PLUS® Cacciavite TORX PLUS®
R/LB106...	1.8.4T6EP	T6PL

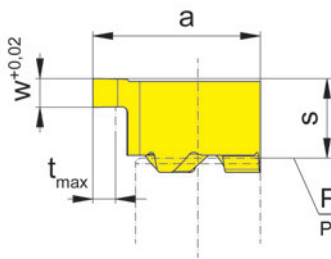
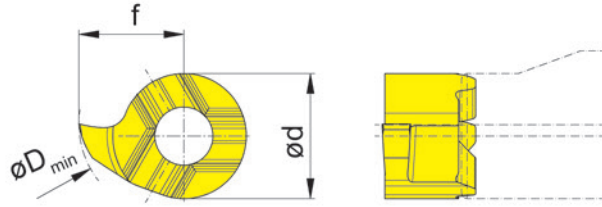
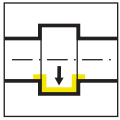

Profil frontal du porte outils  
Profilo frontale del portainsero

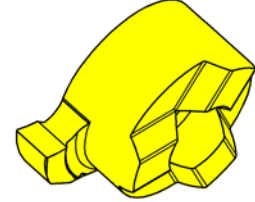

R = version à droite représentée  
R = versione destra come in figura

L = version à gauche  
L = versione sinistra a specchio

▲ en stock  
a stock

Nuance  
Leghe  
Δ 4 semaines  
4 settimane

Numéro de commande Codice prodotto	w	s	f	a	d	t <sub>max</sub>	D <sub>min</sub>	HIS	Nuance Leghe		
									EG55	TH35	
R106.0070.2.00	0,74	2,8	3,7	5,9	4,4	0,8	6,5	106044R	▲	▲	
R106.0100.2.00	1	2,8	3,7	5,9	4,4	0,8	6,5	106044R	Δ	▲	
R106.0150.2.00	1,5	2,8	3,7	5,9	4,4	0,8	6,5	106044R	Δ	▲	
L106.0070.2.00	0,74	2,8	3,7	5,9	4,4	0,8	6,5	106044L	Δ		
L106.0100.2.00	1	2,8	3,7	5,9	4,4	0,8	6,5	106044L	Δ		
L106.0150.2.00	1,5	2,8	3,7	5,9	4,4	0,8	6,5	106044L	Δ	Δ	
									P	●	●
									M	○	●
									K	○	●
									N	-	●
									S	-	●
									H	-	-

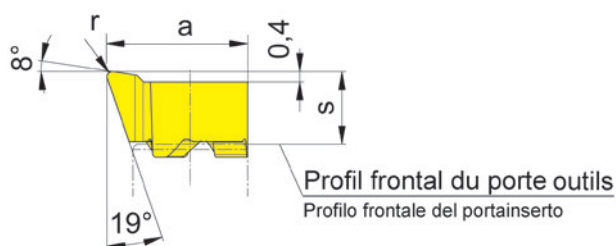
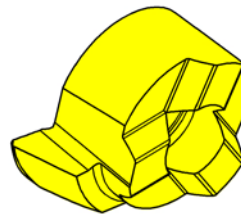
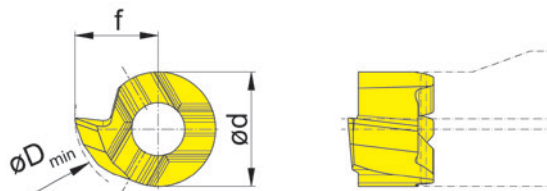
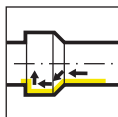

R = version à droite représentée  
R = versione destra come in figura

L = version à gauche  
L = versione sinistra a specchio

▲ en stock  
a stock

Nuance  
Leghe  
Δ 4 semaines  
4 settimane

Numéro de commande Codice prodotto	s	f	a	r	d	D <sub>min</sub>	HIS	Nuance Leghe		
								EG55	TH35	
R106.1831.1.005	2,8	3,2	5,4	0,05	4,4	6	106044R	▲	▲	
R106.1831.1.02	2,8	3,2	5,4	0,2	4,4	6	106044R	▲	▲	
R106.1831.1.04	2,8	3,2	5,4	0,4	4,4	6	106044R	▲	▲	
L106.1831.1.005	2,8	3,2	5,4	0,05	4,4	6	106044L	Δ	Δ	
L106.1831.1.02	2,8	3,2	5,4	0,2	4,4	6	106044L	Δ	▲	
L106.1831.1.04	2,8	3,2	5,4	0,4	4,4	6	106044L		▲	
								P	●	●
								M	○	●
								K	○	●
								N	-	●
								S	-	●
								H	-	-

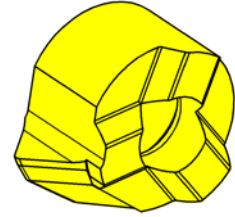
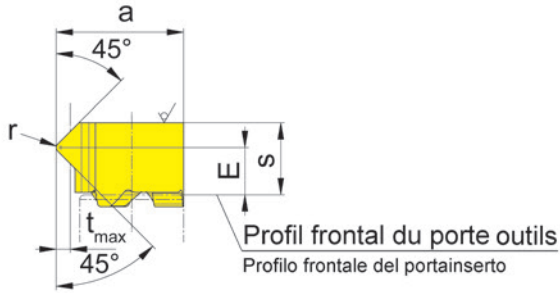
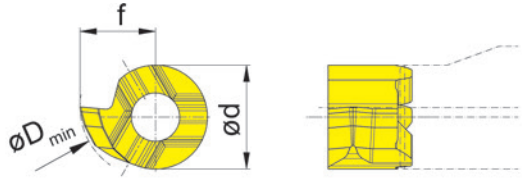
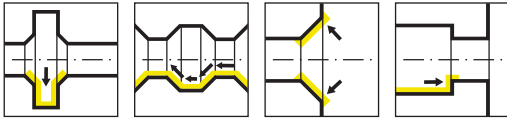

R = version à droite représentée  
R = versione destra come in figura

L = version à gauche  
L = versione sinistra a specchio

▲ en stock  
a stock

Nuance  
Leghe  
Δ 4 semaines  
4 settimane

Numéro de commande Codice prodotto	E	s	f	a	r	d	t <sub>max</sub>	D <sub>min</sub>	HIS	Nuance Leghe	
										EG55	TH35
R106.4545.1.02	2	3,05	3,2	5,4	0,2	4,4	0,6	6	106044R	▲	▲
L106.4545.1.02	2	3,05	3,2	5,4	0,2	4,4	0,6	6	106044L	Δ	
										P	●
										M	○
										K	○
										N	-
										S	-
										H	-

D

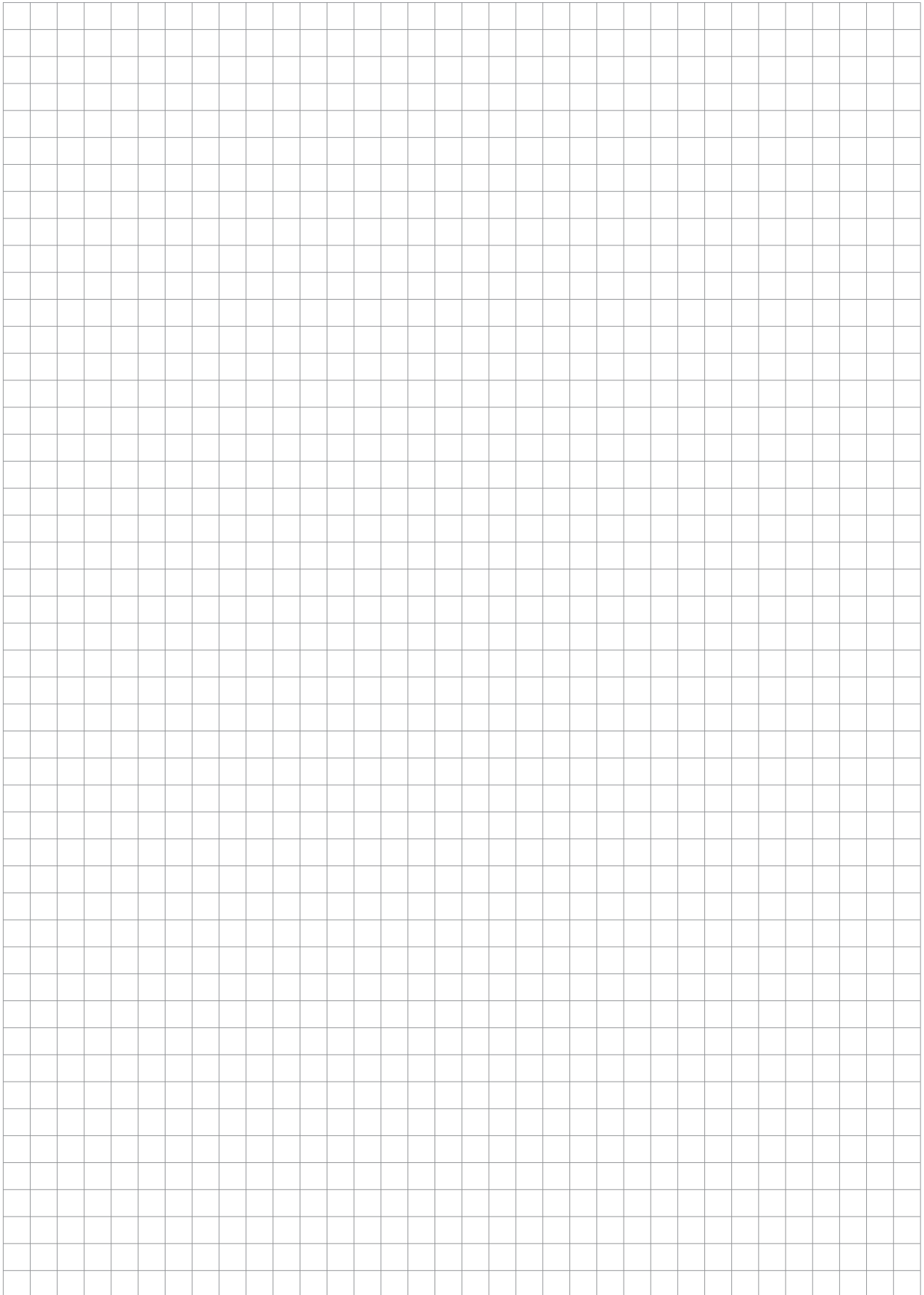

**107**

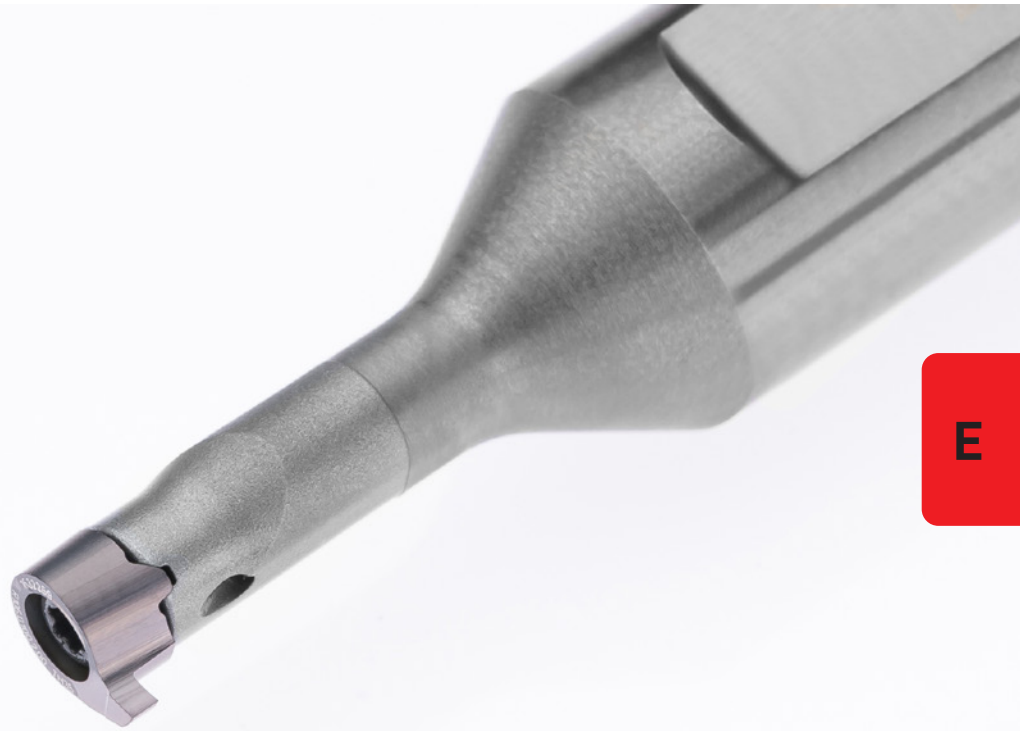

**Porte outils et plaquettes**

**Portainsero e inserti**

Porte outils  
Portainsero  
B107

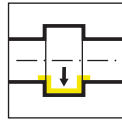

Page/Pag.  
208

Plaque de coupe  
Inserto  
107

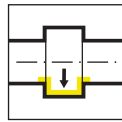

Page/Pag.  
209-210

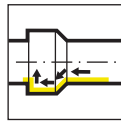

Page/Pag.  
211

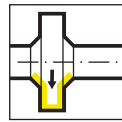

Page/Pag.  
212

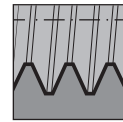

Page/Pag.  
213

Ø Alésage Foro Ø	Type de produit / Linea di prodotto											
	105	109	110	106	107	108	10P	111	11P	114	116	18P
≥ 0,2	•											
≥ 0,5	•											
≥ 0,7	•											
≥ 1,0	•											
≥ 1,5	•											
≥ 2,0	•											
≥ 3,0	•											
≥ 4,0	•											
≥ 5,0	•											
≥ 6,0	•	•	•	•								
≥ 6,8		•	•	•								
≥ 7,0		•			•							
≥ 7,8			•		•	•						
≥ 8,0			•		•	•						
≥ 9,0			•		•	•	•					
≥ 10,0			•				•	•	•			
≥ 10,5									•			
≥ 11,0								•	•			
≥ 11,5									•			
≥ 13,8										•		
≥ 14,0										•	•	
≥ 16,0											•	
≥ 16,5										{•}		
≥ 18,0												•
Profondeur de gorge Profondità della gola	2,5	2,5	4,0	0,8	2,0	1,0	3,0	2,3	3,5	4,0 (6,5)	4,3	8,0
Largeur de gorge Larghezza della gola	0,5- 2,0	1,0- 2,0	1,0- 3,0	0,7- 1,5	1,0- 2,0	0,7- 2,0	1,0- 3,0	0,7- 3,0	1,0- 3,0	0,7- 3,0	0,7- 4,0	2,0- 3,0
Usinage / Operazione												
Gorge Gole	•	•	•	•	•	•	•	•	•	•	•	•
Alésage Alesatura	•	•	•	•	•	•		•		•	•	
Filetage Filettatura	•	•			•	•		•		•	•	
Chanfreinage Smussatura	•	•			•	•		•		•	•	
Gorge frontale Gole assiali	•	•	•							•		
Alésage et Profil Alesatura e Profilatura	•											



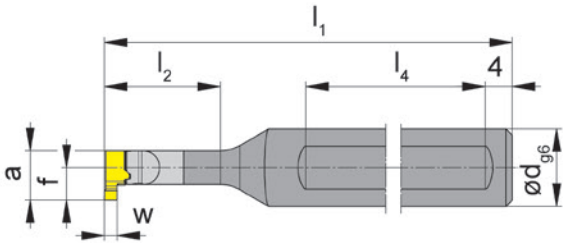
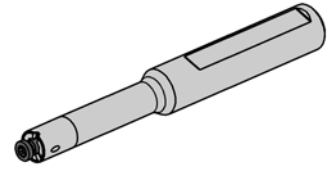
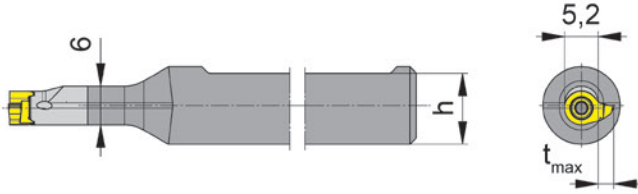
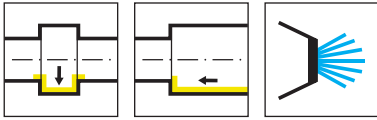

R = version à droite représentée  
R = versione destra come in figura

L = version à gauche  
L = versione sinistra a specchio

Numéro de commande Codice prodotto	d	l <sub>1</sub>	l <sub>2</sub>	h	l <sub>4</sub>	HWS
RB107.0012.01	12	80	18	11	45	107052R
RB107.0012.02	12	90	26	11	45	107052R
RB107.0012.03	12	100	36	11	45	107052R
LB107.0012.01	12	80	18	11	45	107052L
LB107.0012.02	12	90	26	11	45	107052L
LB107.0012.03	12	100	36	11	45	107052L

w, a, tmax et f voir plaquettes  
w, a, tmax, f vd. Inserti

Pièces Détachées

Ricambi

Porte outils Portainsero	Vis de serrage Vite di serraggio	Tournevis TORX PLUS® Cacciavite TORX PLUS®
R/LB107...	2.2.5T7EP	T7PL

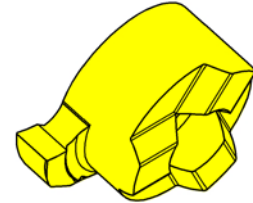
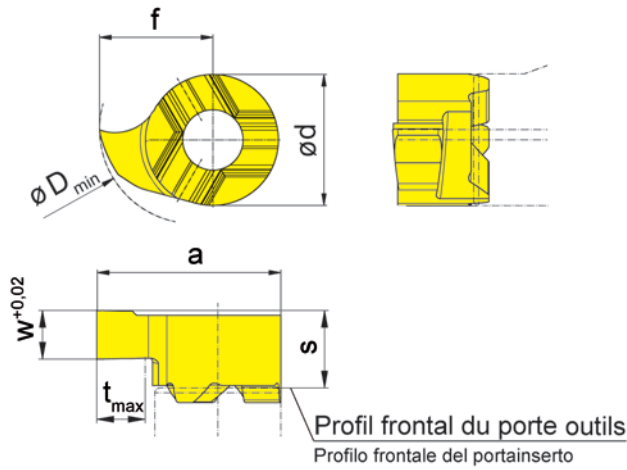
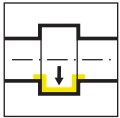

R = version à droite représentée  
R = versione destra come in figura

L = version à gauche  
L = versione sinistra a specchio

▲ en stock  
a stock

Nuance  
Leghe  
Δ 4 semaines  
4 settimane

Numéro de commande Codice prodotto	w	s	f	a	d	t <sub>max</sub>	D <sub>min</sub>	HIS	Nuance Leghe		
									EG55	TH35	
R107.0100.1.00	1	3,3	4	6,6	5,2	1	7	107052R	▲	▲	
R107.0150.1.00	1,5	3,3	4	6,6	5,2	1	7	107052R	▲	▲	
L107.0100.1.00	1	3,3	4	6,6	5,2	1	7	107052L	Δ	Δ	
L107.0150.1.00	1,5	3,3	4	6,6	5,2	1	7	107052L	Δ	▲	
									P	●	●
									M	○	●
									K	○	●
									N	-	●
									S	-	●
									H	-	-



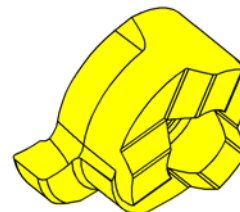
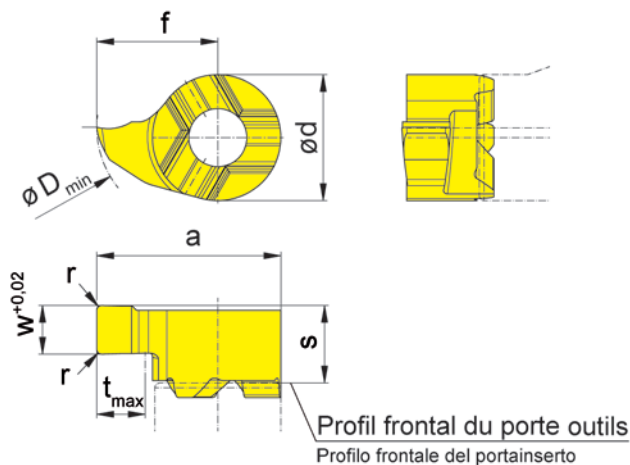
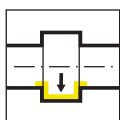

E

R = version à droite représentée  
R = versione destra come in figura

L = version à gauche  
L = versione sinistra a specchio

▲ en stock  
a stock

Nuance  
Leghe  
Δ 4 semaines  
4 settimane

Numéro de commande Codice prodotto	w	s	f	a	r	d	t <sub>max</sub>	D <sub>min</sub>	HIS	Nuance	
										EG55	TH35
R107.0100.2.00	1	3,3	5	7,6	-	5,2	2	8	107052R	▲	▲
R107.0150.2.01	1,5	3,3	5	7,6	0,1	5,2	2	8	107052R	▲	▲
R107.0200.2.02	2	3,3	5	7,6	0,2	5,2	2	8	107052R	▲	▲
L107.0100.2.00	1	3,3	5	7,6	-	5,2	2	8	107052L	Δ	Δ
L107.0150.2.01	1,5	3,3	5	7,6	0,1	5,2	2	8	107052L	Δ	▲
L107.0200.2.02	2	3,3	5	7,6	0,2	5,2	2	8	107052L	Δ	▲
										P	●
										M	○
										K	○
										N	-
										S	-
										H	-

# Plaquette de coupe

## Inserto

# 107

$\varnothing \geq 6,8 \text{ mm}$

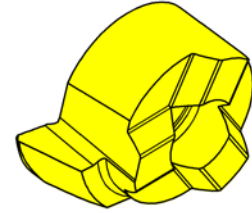
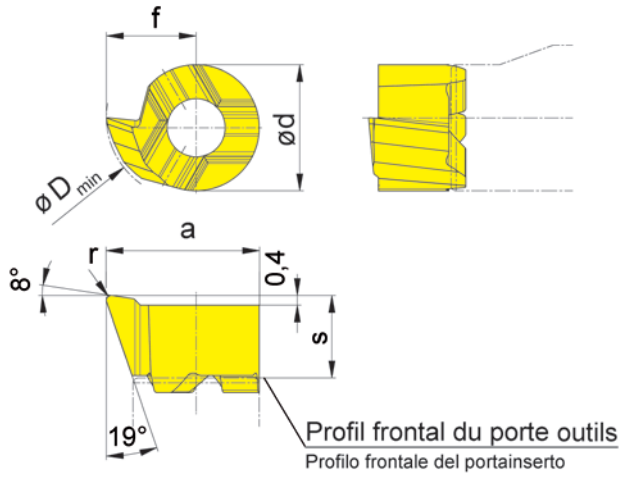
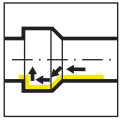

R = version à droite représentée  
R = versione destra come in figura

L = version à gauche  
L = versione sinistra a specchio

▲ en stock  
a stock

Nuance  
Leghe  
Δ 4 semaines  
4 settimane

Numéro de commande Codice prodotto	s	f	a	r	d	D <sub>min</sub>	HIS	Nuance Leghe	
								EG55	TH35
<b>R107.1837.02</b>	3,3	3,7	6,3	0,2	5,2	6,8	107052R	▲	▲
<b>R107.1837.04</b>	3,3	3,7	6,3	0,4	5,2	6,8	107052R	▲	▲
<b>L107.1837.02</b>	3,3	3,7	6,3	0,2	5,2	6,8	107052L	▲	▲
<b>L107.1837.04</b>	3,3	3,7	6,3	0,4	5,2	6,8	107052L	▲	▲
								P	● ●
								M	○ ●
								K	○ ●
								N	- ●
								S	- ●
								H	- -



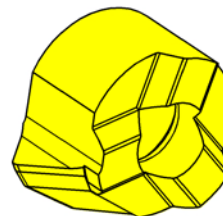
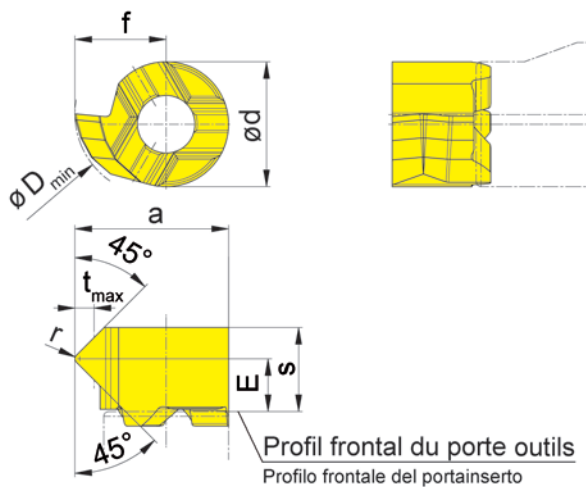

E

R = version à droite représentée  
R = versione destra come in figura

L = version à gauche  
L = versione sinistra a specchio

▲ en stock  
a stock

Nuance  
Leghe  
Δ 4 semaines  
4 settimane

Numéro de commande Codice prodotto	E	s	f	a	r	d	t <sub>max</sub>	D <sub>min</sub>	HIS	Nuance Leghe	
										EG55	TH35
R107.4545.1.02	2,2	3,5	3,8	6,4	0,2	5,2	0,8	6,8	107052R	▲	▲
L107.4545.1.02	2,2	3,5	3,8	6,4	0,2	5,2	0,8	6,8	107052L	Δ	Δ
										P	● ●
										M	○ ●
										K	○ ●
										N	- ●
										S	- ●
										H	- -

# Plaquette de coupe

## Inserto

# 107

$\varnothing \geq 7 \text{ mm}$

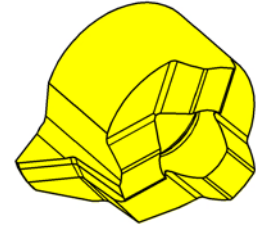
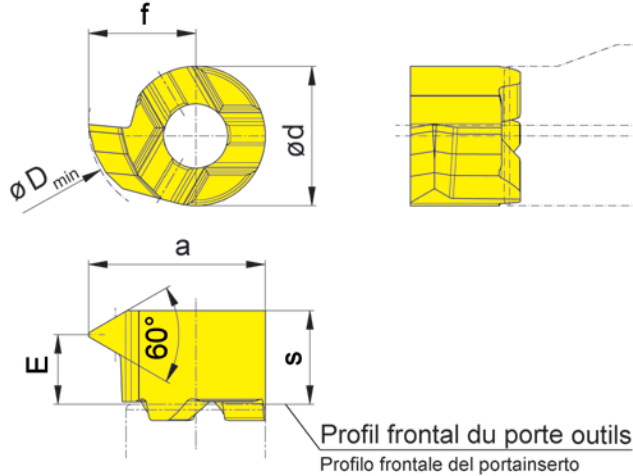

R = version à droite représentée  
R = versione destra come in figura

L = version à gauche  
L = versione sinistra a specchio

▲ en stock  
a stock

Nuance  
Leghe  
Δ 4 semaines  
4 settimane

Numéro de commande Codice prodotto	P	P <sub>max</sub>	E	f	a	d	s	D <sub>min</sub>	HIS	Nuance Leghe	
										EG55	TH35
R107.0205.1.01	0,5	0,75	3	4	6,6	5,2	3,5	7	107052R	▲	▲
R107.0510.1.01	1	1,25	2,8	4	6,6	5,2	3,5	7	107052R	▲	▲
R107.0815.1.01	1,5	1,75	2,6	4	6,6	5,2	3,5	7	107052R	▲	▲
L107.0205.1.01	0,5	0,75	3	4	6,6	5,2	3,5	7	107052L	Δ	Δ
L107.0510.1.01	1	1,25	2,8	4	6,6	5,2	3,5	7	107052L	Δ	▲
L107.0815.1.01	1,5	1,75	2,6	4	6,6	5,2	3,5	7	107052L	Δ	Δ
										P	● ●
										M	○ ●
										K	○ ●
										N	- ●
										S	- ●
										H	- -



E



**108**



**F**

**Porte outils et plaquettes**

**Portainsero e inserti**

Porte outils  
Portainsero  
B108

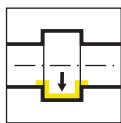

Page/Pag.  
218

Plaque de coupe  
Inserto  
108/S108



Page/Pag.  
219-220

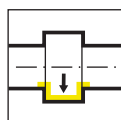

Page/Pag.  
221



Page/Pag.  
222

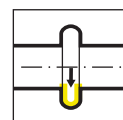

Page/Pag.  
223

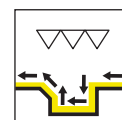

Page/Pag.  
224



Page/Pag.  
225



Page/Pag.  
226

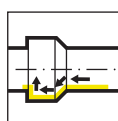

Page/Pag.  
227, 230-231



Page/Pag.  
228

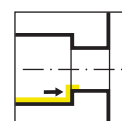

Page/Pag.  
229

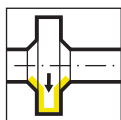

Page/Pag.  
232

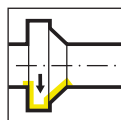

Page/Pag.  
233

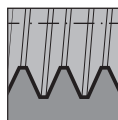

Page/Pag.  
234-238

F

Ø Alésage Foro Ø	Type de produit / Linea di prodotto											
	105	109	110	106	107	108	10P	111	11P	114	116	18P
≥ 0,2	•											
≥ 0,5	•											
≥ 0,7	•											
≥ 1,0	•											
≥ 1,5	•											
≥ 2,0	•											
≥ 3,0	•											
≥ 4,0	•											
≥ 5,0	•											
≥ 6,0	•	•	•	•								
≥ 6,8		•	•	•								
≥ 7,0		•			•							
≥ 7,8			•		•	•						
≥ 8,0			•		•	•						
≥ 9,0			•		•	•	•					
≥ 10,0			•				•	•	•			
≥ 10,5									•			
≥ 11,0								•	•			
≥ 11,5									•			
≥ 13,8										•		
≥ 14,0										•	•	
≥ 16,0											•	
≥ 16,5										{•}		
≥ 18,0												•
Profondeur de gorge Profondità della gola	2,5	2,5	4,0	0,8	2,0	1,0	3,0	2,3	3,5	4,0 (6,5)	4,3	8,0
Largeur de gorge Larghezza della gola	0,5- 2,0	1,0- 2,0	1,0- 3,0	0,7- 1,5	1,0- 2,0	0,7- 2,0	1,0- 3,0	0,7- 3,0	1,0- 3,0	0,7- 3,0	0,7- 4,0	2,0- 3,0
Usinage / Operazione												
Gorge Gole	•	•	•	•	•	•	•	•	•	•	•	•
Alésage Alesatura	•	•	•	•	•	•		•		•	•	
Filetage Filettatura	•	•			•	•		•		•	•	
Chanfreinage Smussatura	•	•			•	•		•		•	•	
Gorge frontale Gole assiali	•	•	•							•		
Alésage et Profil Alesatura e Profilatura	•											

F

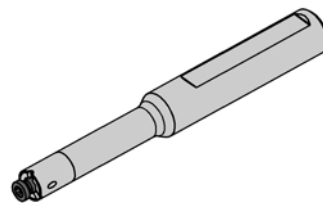
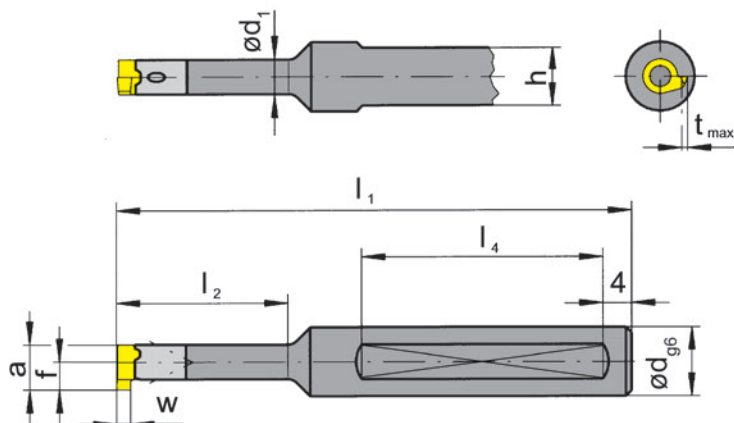
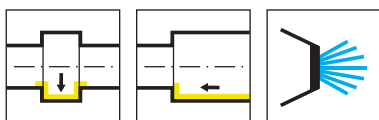

Illustration de coupe à droite représentée

Figura = taglio destro

F

Numéro de commande Codice prodotto	d	l <sub>1</sub>	l <sub>2</sub>	h	l <sub>4</sub>	d <sub>1</sub>	HWS
B108.0006.01A	6	65	-	-	-	-	108060R • 108060L
B108.0008.00	8	60	12,5	7	35	6	108060R • 108060L
B108.0008.01	8	70	21	7	40	6	108060R • 108060L
B108.0012.00	12	70	12,5	11	40	6	108060R • 108060L
B108.0012.01	12	80	21	11	45	6	108060R • 108060L
B108.0012.02	12	90	30	11	45	6	108060R • 108060L
B108.0012.03	12	100	42	11	45	6	108060R • 108060L

w, a, tmax et f voir plaquettes

w, a, tmax, f vd. Inserti

### Pièces Détachées

Ricambi

Porte outils Portainsero	Vis de serrage Vite di serraggio	Tournevis TORX PLUS® Cacciavite TORX PLUS®
B108...	2.6.5T8EP	T8PL

# Plaquette de coupe Inserto

# 108

$\varnothing \geq 8 \text{ mm}$

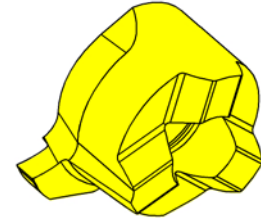
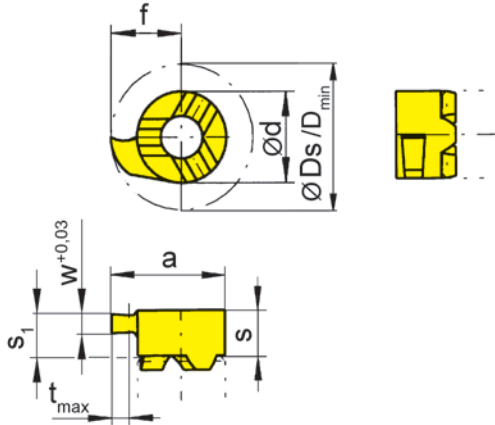
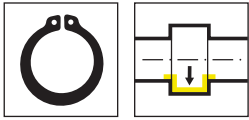

R = version à droite représentée  
R = versione destra come in figura

L = version à gauche  
L = versione sinistra a specchio

▲ en stock  
a stock

Nuance  
Leghe  
Δ 4 semaines  
4 settimane

Numéro de commande Codice prodotto	w	Nw	f	Ds	d	s	s <sub>1</sub>	a	t <sub>max</sub>	D <sub>min</sub>	Z	HIS	Nuance Leghe			
													EG55	TH35	TN35	
<b>R108.0070.00</b>	0,74	0,7	4,8	9,6	6	3,6	3,2	7,8	1	8	1	108060R	▲	▲	▲	
<b>R108.0080.00</b>	0,84	0,8	4,8	9,6	6	3,6	3,2	7,8	1	8	1	108060R	▲	▲	▲	
<b>R108.0090.00</b>	0,94	0,9	4,8	9,6	6	3,6	3,2	7,8	1	8	1	108060R	▲	▲	▲	
<b>L108.0070.00</b>	0,74	0,7	4,8	9,6	6	3,6	3,2	7,8	1	8	1	108060L	Δ	▲	▲	
<b>L108.0080.00</b>	0,84	0,8	4,8	9,6	6	3,6	3,2	7,8	1	8	1	108060L	Δ	Δ	▲	
<b>L108.0090.00</b>	0,94	0,9	4,8	9,6	6	3,6	3,2	7,8	1	8	1	108060L	Δ	▲	▲	
Profondeur de coupe limitée Profondità di taglio limitata													<b>P</b>	●	●	●
Largeurs pour gorges circlips DIN 471/472 Larghezza per esecuzione anelli Seeger DIN 471/472													<b>M</b>	○	●	●
													<b>K</b>	○	●	●
													<b>N</b>	-	●	●
													<b>S</b>	-	●	●
													<b>H</b>	-	-	-



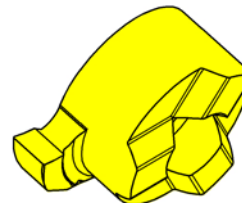
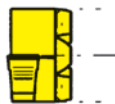
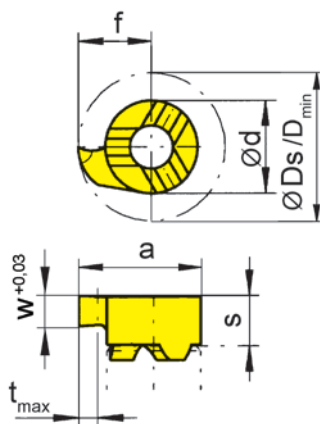
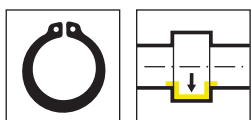

R = version à droite représentée  
R = versione destra come in figura

L = version à gauche  
L = versione sinistra a specchio

▲ en stock  
a stock

Nuance  
Leghe  
Δ 4 semaines  
4 settimane

Numéro de commande Codice prodotto	w	Nw	s	f	Ds	a	d	t <sub>max</sub>	D <sub>min</sub>	Z	HIS	Nuance Leghe		
												EG55	TH35	TN35
R108.0110.00	1,19	1,1	3,2	4,8	9,6	7,8	6	1	8	1	108060R	▲	▲	▲
R108.0160.00	1,69	1,6	3,2	4,8	9,6	7,8	6	1	8	1	108060R	Δ	▲	▲
R108.0130.00	1,39	1,3	3,2	4,8	9,6	7,8	6	1	8	1	108060R	▲	▲	▲
L108.0110.00	1,19	1,1	3,2	4,8	9,6	7,8	6	1	8	1	108060L	Δ	▲	▲
L108.0160.00	1,69	1,6	3,2	4,8	9,6	7,8	6	1	8	1	108060L	▲	Δ	▲
L108.0130.00	1,39	1,3	3,2	4,8	9,6	7,8	6	1	8	1	108060L		Δ	▲

Largeurs pour gorges circlips DIN 471/472  
Larghezza per esecuzione anelli Seeger DIN 471/472

	EG55	TH35	TN35
P	●	●	●
M	○	●	●
K	○	●	●
N	-	●	●
S	-	●	●
H	-	-	-

# Plaquette de coupe

## Inserto

# 108

$\emptyset \geq 8 \text{ mm}$

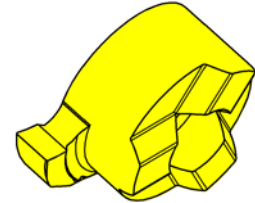
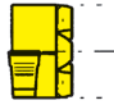
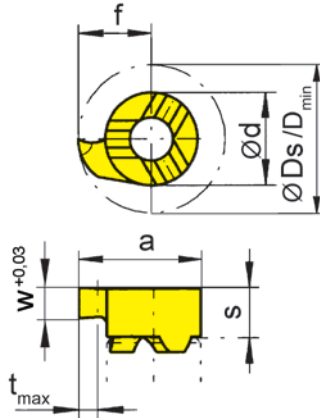
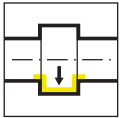

R = version à droite représentée  
R = versione destra come in figura

L = version à gauche  
L = versione sinistra a specchio

▲ en stock  
a stock

Nuance  
Leghe  
Δ 4 semaines  
4 settimane

Numéro de commande Codice prodotto	w	s	f	Ds	a	d	t <sub>max</sub>	D <sub>min</sub>	Z	HIS	Nuance Leghe		
											EG55	TH35	TN35
<b>R108.0150.00</b>	1,5	3,2	4,8	9,6	7,8	6	1	8	1	108060R	▲	▲	▲
<b>R108.0200.00</b>	2	3,2	4,8	9,6	7,8	6	1	8	1	108060R	▲	▲	▲
<b>L108.0150.00</b>	1,5	3,2	4,8	9,6	7,8	6	1	8	1	108060L		Δ	▲
<b>L108.0200.00</b>	2	3,2	4,8	9,6	7,8	6	1	8	1	108060L		▲	▲
<b>P</b>	●	●	●										
<b>M</b>	○	●	●										
<b>K</b>	○	●	●										
<b>N</b>	-	●	●										
<b>S</b>	-	●	●										
<b>H</b>	-	-	-										



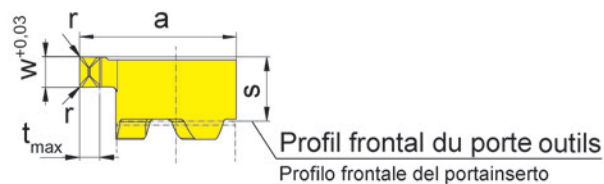
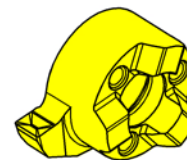
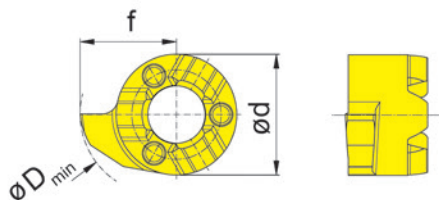
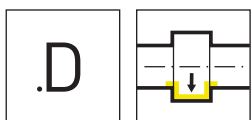

F

R = version à droite représentée  
R = versione destra come in figura

L = version à gauche  
L = versione sinistra a specchio

▲ en stock  
a stock

Nuance  
Leghe  
Δ 4 semaines  
4 settimane

Numéro de commande Codice prodotto	w	s	f	a	r	d	t <sub>max</sub>	D <sub>min</sub>	HIS	Nuance Leghe	
										EG55	TH35
RS108.0100.D1	1	3,2	4,8	7,8	0,1	6	1	8	108060R	▲	▲
RS108.0150.D1	1,5	3,2	4,8	7,8	0,1	6	1	8	108060R	▲	▲
RS108.0200.D2	2	3,2	4,8	7,8	0,2	6	1	8	108060R	▲	▲
LS108.0100.D1	1	3,2	4,8	7,8	0,1	6	1	8	108060L	Δ	▲
LS108.0150.D1	1,5	3,2	4,8	7,8	0,1	6	1	8	108060L	Δ	Δ
LS108.0200.D2	2	3,2	4,8	7,8	0,2	6	1	8	108060L	Δ	▲
										P	●
										M	○
										K	○
										N	-
										S	-
										H	-

# Plaquette de coupe

## Inserto

# 108

$\varnothing \geq 8 \text{ mm}$

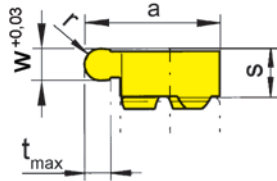
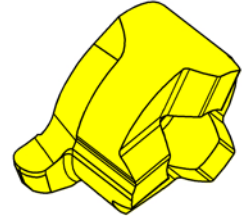
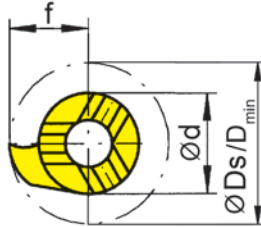
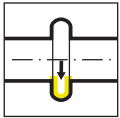

R = version à droite représentée  
R = versione destra come in figura

L = version à gauche  
L = versione sinistra a specchio

▲ en stock  
a stock

Nuance  
Leghe  
Δ 4 semaines  
4 settimane

Numéro de commande Codice prodotto	w	s	f	Ds	a	r	d	t <sub>max</sub>	D <sub>min</sub>	Z	HIS	Nuance Leghe		
												EG55	TH35	TN35
<b>R108.0004.08</b>	0,8	3,2	4,8	9,6	7,8	0,4	6	1	8	1	108060R	▲	▲	▲
<b>R108.0006.12</b>	1,2	3,2	4,8	9,6	7,8	0,6	6	1	8	1	108060R	▲	▲	▲
<b>R108.0009.18</b>	1,8	3,2	4,8	9,6	7,8	0,9	6	1	8	1	108060R	▲	▲	▲
<b>L108.0004.08</b>	0,8	3,2	4,8	9,6	7,8	0,4	6	1	8	1	108060L	▲	▲	▲
<b>L108.0006.12</b>	1,2	3,2	4,8	9,6	7,8	0,6	6	1	8	1	108060L	▲	▲	▲
<b>L108.0009.18</b>	1,8	3,2	4,8	9,6	7,8	0,9	6	1	8	1	108060L	▲	▲	▲
<b>P</b>	●	●	●											
<b>M</b>	○	●	●											
<b>K</b>	○	●	●											
<b>N</b>	-	●	●											
<b>S</b>	-	●	●											
<b>H</b>	-	-	-											



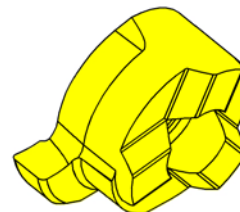
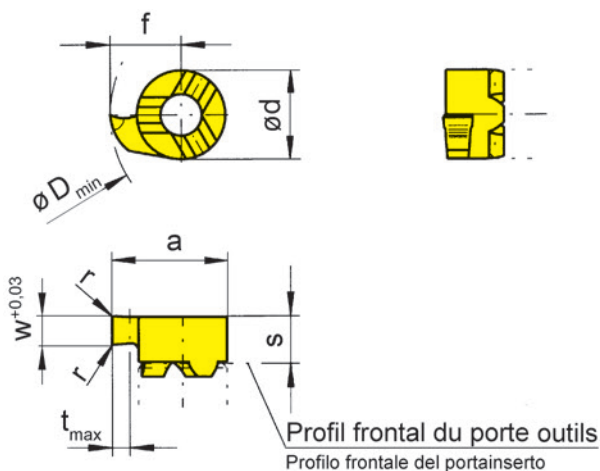
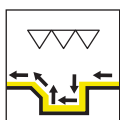

Nuance  
Leghe

R = version à droite représentée  
R = versione destra come in figura

L = version à gauche  
L = versione sinistra a specchio

▲ en stock  
a stock

Δ 4 semaines  
4 settimane

F

Numéro de commande Codice prodotto	w	s	f	a	r	d	t <sub>max</sub>	D <sub>min</sub>	HIS	Nuance Leghe			
										EG55	TH35	TI25	TN35
R108.0150.02	1,5	3,2	4,8	7,8	0,2	6	1	8	108060R	▲	▲	▲	▲
L108.0150.02	1,5	3,2	4,8	7,8	0,2	6	1	8	108060L	▲	▲	Δ	▲
P	●	●	●	●	●	●	●	●		●	●	●	●
M	○	●	●	●	●	●	●	●		○	●	●	●
K	○	●	●	●	●	●	●	●		○	●	●	●
N	-	●	●	●	●	●	●	●		-	●	●	●
S	-	●	●	●	●	●	●	●		-	●	●	●
H	-	-	-	-	-	-	-	-		-	-	-	-

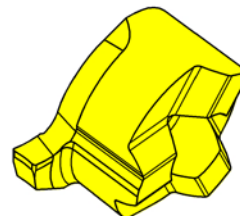
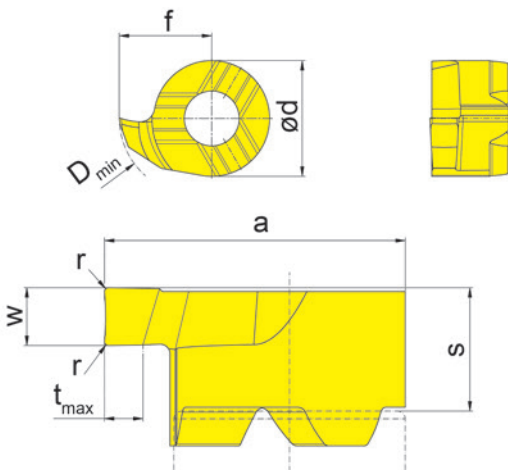

R = version à droite représentée  
R = versione destra come in figura

L = version à gauche  
L = versione sinistra a specchio

▲ en stock  
a stock

Nuance  
Leghe  
Δ 4 semaines  
4 settimane

Número de commande Codice prodotto	w	s	f	a	r	d	t <sub>max</sub>	D <sub>min</sub>	HIS	EG35
R108.FB10.01	1	3,2	4,8	7,8	0,1	6	1	8	108060R	▲
R108.FB15.01	1,5	3,2	4,8	7,8	0,1	6	1	8	108060R	▲
L108.FB10.01	1	3,2	4,8	7,8	0,1	6	1	8	108060L	▲
L108.FB15.01	1,5	3,2	4,8	7,8	0,1	6	1	8	108060L	▲

P	●
M	●
K	○
N	-
S	-
H	-

Calcul de la plus petite largeur de gorge possible  $w_x$   
Calcolo della larghezza di gola  $w_x$  più basso possibile

Exemple R108.FB10.01  
Esempio

$w_x = 2 \times$  Largeur de gorge  $w - 2 \times$  Rayon d'angles plaquette  $r$

$w_x = 2 \times$  Larghezza della gola  $w - 2 \times$  Spigolo raggiato inserto  $r$

$w_x = 2 \times 1 \text{ mm} - 2 \times 0,1 \text{ mm}$

$w_x = 1,8 \text{ mm}$

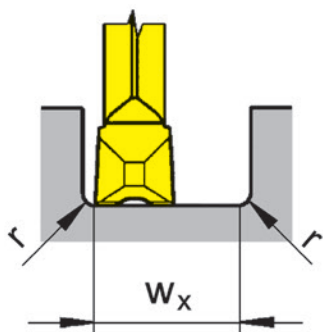

Déroulement du processus  
Percorso di lavoro



# Plaquette de coupe

Inserto

# S108

$\emptyset \geq 7,8 \text{ mm}$

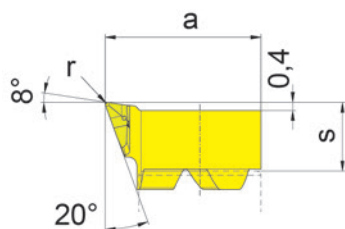
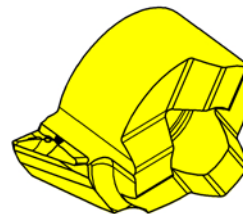
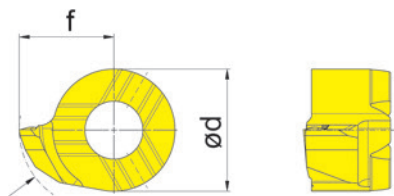
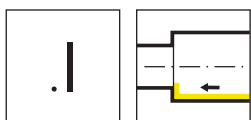

R = version à droite représentée  
R = versione destra come in figura

▲ en stock  
a stock

Nuance  
Leghe  
Δ 4 semaines  
4 settimane

F

Numéro de commande Codice prodotto	s	f	a	r	d	D <sub>min</sub>	HIS	Nuance Leghe		
								EG35	EG55	IG35
RS108.0820.105	3,37	4,65	7,65	0,05	6	7,8	108060R	▲	-	▲
RS108.0820.110	3,38	4,65	7,65	0,1	6	7,8	108060R	▲	-	▲
RS108.0820.120	3,4	4,65	7,65	0,2	6	7,8	108060R	-	▲	▲
P	●	●	-	-	-	-	-	-	-	-
M	●	○	●	-	-	-	-	-	-	-
K	○	○	-	-	-	-	-	-	-	-
N	-	-	-	-	-	-	-	-	-	-
S	-	-	-	-	-	-	-	-	-	●
H	-	-	-	-	-	-	-	-	-	-

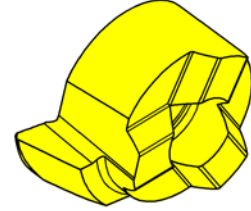
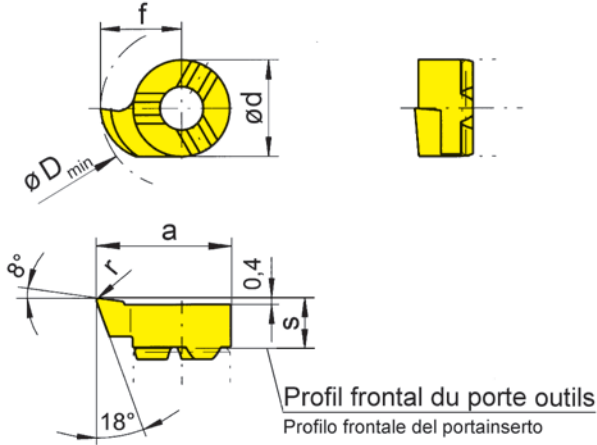
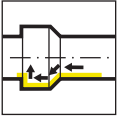

R = version à droite représentée  
R = versione destra come in figura

L = version à gauche  
L = versione sinistra a specchio

▲ en stock  
a stock

Nuance  
Leghe  
Δ 4 semaines  
4 settimane

Numéro de commande Codice prodotto	s	f	a	r	d	D <sub>min</sub>	HIS	Nuance Leghe			
								EG55	TH35	TI25	TN35
R108.1846.02	3,4	4,65	7,65	0,2	6	7,8	108060R	▲	▲	▲	▲
L108.1846.02	3,4	4,65	7,65	0,2	6	7,8	108060L	▲	▲	▲	▲
P	●	●	●	●	●	●		●	●	●	●
M	○	●	●	●	●	●		○	●	●	●
K	○	●	●	●	●	●		○	●	●	●
N	-	●	●	●	●	●		-	●	●	●
S	-	●	●	●	●	●		-	●	●	●
H	-	-	-	-	-	-		-	-	-	-



# Plaquette de coupe Inserto

## S108 $\varnothing \geq 7,8$ mm

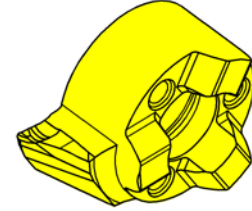
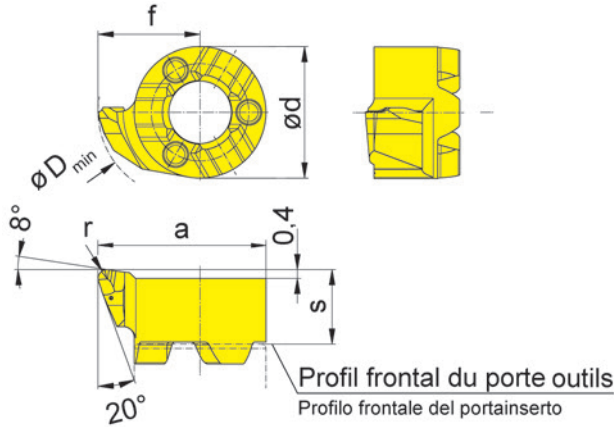
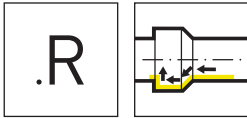

R = version à droite représentée  
R = versione destra come in figura

L = version à gauche  
L = versione sinistra a specchio

▲ en stock  
a stock

Nuance  
Leghe  
Δ 4 semaines  
4 settimane

Numéro de commande Codice prodotto	s	f	a	r	d	D <sub>min</sub>	HIS	Nuance Leghe	
								EG55	TH35
RS108.1846.R2	3,4	4,65	7,65	0,2	6	7,8	108060R	▲	▲
RS108.1846.R4	3,4	4,65	7,65	0,4	6	7,8	108060R	▲	▲
LS108.1846.R2	3,4	4,65	7,65	0,2	6	7,8	108060L	▲	▲
LS108.1846.R4	3,4	4,65	7,65	0,4	6	7,8	108060L	▲	▲
								P	● ●
								M	○ ●
								K	○ ●
								N	- ●
								S	- ●
								H	- -

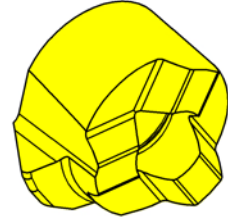
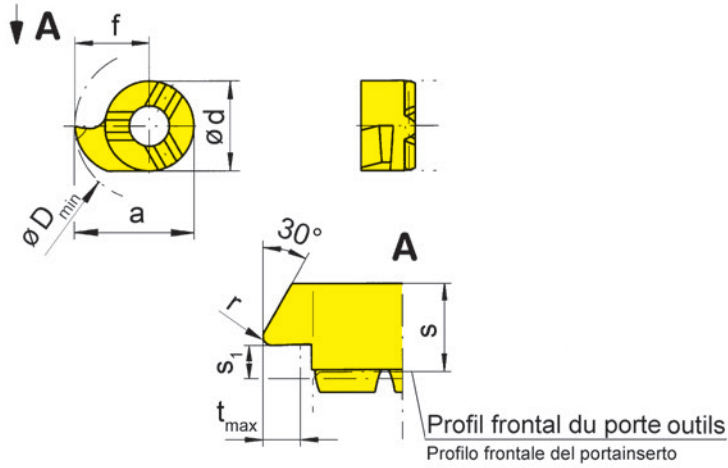
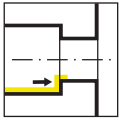

R = version à droite représentée  
R = versione destra come in figura

L = version à gauche  
L = versione sinistra a specchio

▲ en stock  
a stock

Nuance  
Leghe  
Δ 4 semaines  
4 settimane

Numéro de commande Codice prodotto	s	f	a	r	s <sub>1</sub>	d	t <sub>max</sub>	D <sub>min</sub>	HIS	Nuance Leghe		
										EG55	TH35	TN35
R108.3046.02	3,6	4,65	7,65	0,2	0,8	6	1,3	7,8	108060R	▲	▲	▲
L108.3046.02	3,6	4,65	7,65	0,2	0,8	6	1,3	7,8	108060L	Δ	Δ	▲
P	●	●	●									
M	○	●	●									
K	○	●	●									
N	-	●	●									
S	-	●	●									
H	-	-	-									



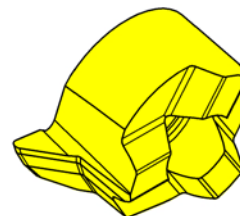
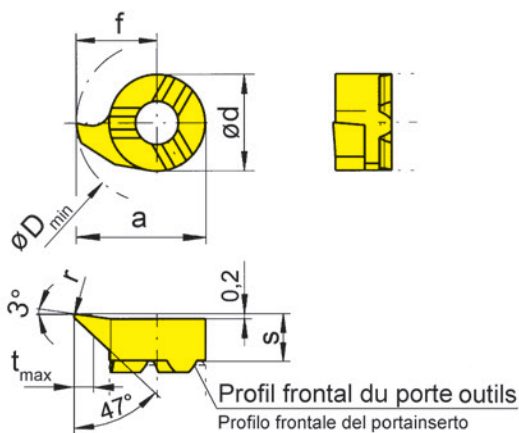
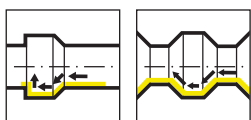

F

R = version à droite représentée  
R = versione destra come in figura

L = version à gauche  
L = versione sinistra a specchio

▲ en stock  
a stock

Nuance  
Leghe  
Δ 4 semaines  
4 settimane

Numéro de commande Codice prodotto	s	f	a	r	d	t <sub>max</sub>	D <sub>min</sub>	HIS	Nuance Leghe		
									EG55	TH35	TN35
R108.4748.01	3,2	4,65	7,65	0,1	6	1,2	7,8	108060R	▲	▲	
R108.4748.02	3,2	4,65	7,65	0,2	6	1,2	7,8	108060R	▲	▲	▲
R108.4748.04	3,2	4,65	7,65	0,4	6	1,2	7,8	108060R	▲	▲	
L108.4748.01	3,2	4,65	7,65	0,1	6	1,2	7,8	108060L	▲	▲	
L108.4748.02	3,2	4,65	7,65	0,2	6	1,2	7,8	108060L	▲	▲	▲
L108.4748.04	3,2	4,65	7,65	0,4	6	1,2	7,8	108060L	▲	▲	
P	●	●	●								
M	○	●	●								
K	○	●	●								
N	-	●	●								
S	-	●	●								
H	-	-	-								

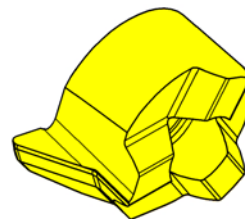
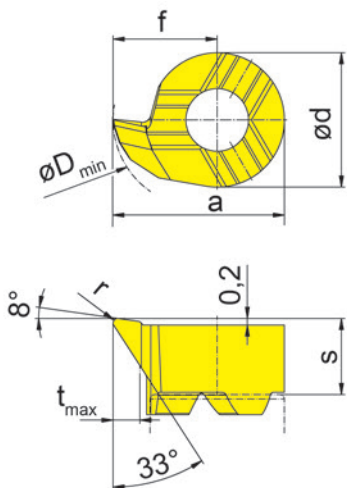
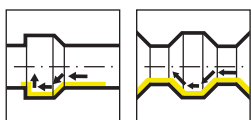

R = version à droite représentée  
R = versione destra come in figura

L = version à gauche  
L = versione sinistra a specchio

▲ en stock  
a stock

Nuance  
Leghe  
Δ 4 semaines  
4 settimane

Numéro de commande Codice prodotto	s	f	a	r	d	t <sub>max</sub>	D <sub>min</sub>	HIS	EG55
R108.3348.01	3,4	4,65	7,65	0,1	6	1,2	7,8	108060R	▲
R108.3348.02	3,4	4,65	7,65	0,2	6	1,2	7,8	108060R	▲
R108.3348.04	3,4	4,65	7,65	0,4	6	1,2	7,8	108060R	▲
L108.3348.01	3,4	4,65	7,65	0,1	6	1,2	7,8	108060L	Δ
L108.3348.02	3,4	4,65	7,65	0,2	6	1,2	7,8	108060L	Δ
L108.3348.04	3,4	4,65	7,65	0,4	6	1,2	7,8	108060L	Δ
									P ●
									M ○
									K ○
									N -
									S -
									H -



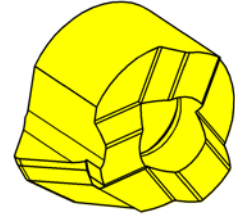
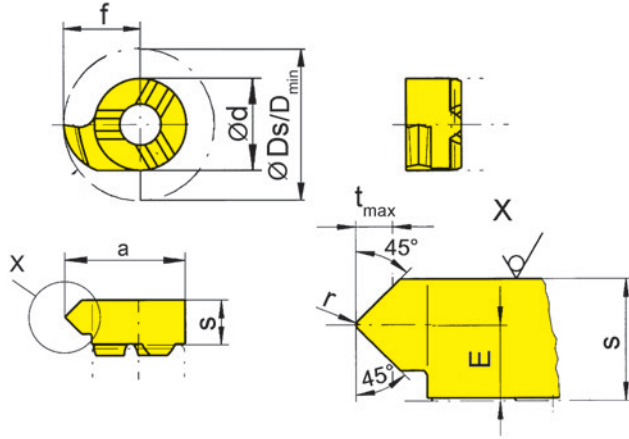
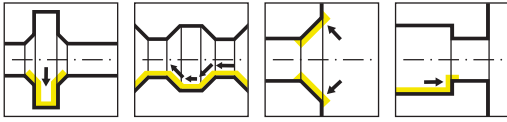

F

R = version à droite représentée  
R = versione destra come in figura

L = version à gauche  
L = versione sinistra a specchio

Nuance  
Leghe  
▲ en stock  
a stock  
Δ 4 semaines  
4 settimane

Numéro de commande Codice prodotto	E	f	Ds	r	d	s	a	D <sub>min</sub>	α	t <sub>max</sub>	Z	HIS	Nuance Leghe			
													EG55	TA45	TI25	TN35
<b>R108.4545.02</b>	1,8	4,65	9,3	0,2	6	3,6	7,65	7,8	45°	1,4	1	108060R	▲	▲	▲	▲
<b>L108.4545.02</b>	1,8	4,65	9,3	0,2	6	3,6	7,65	7,8	45°	1,4	1	108060L	▲	Δ	Δ	▲
<b>P</b>	●	●	●	●	●	●	●	●	●	●	●	●	●	●	●	●
<b>M</b>	○	●	●	●	●	●	●	●	●	●	●	●	●	●	●	●
<b>K</b>	○	●	●	●	●	●	●	●	●	●	●	●	●	●	●	●
<b>N</b>	-	●	●	●	●	●	●	●	●	●	●	●	●	●	●	●
<b>S</b>	-	●	●	●	●	●	●	●	●	●	●	●	●	●	●	●
<b>H</b>	-	-	-	-	-	-	-	-	-	-	-	-	-	-	-	-

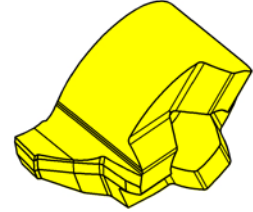
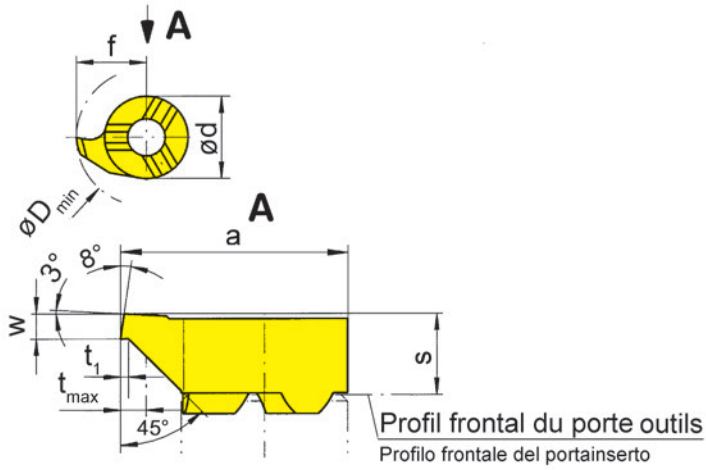
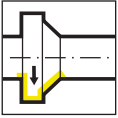

R = version à droite représentée  
R = versione destra come in figura

L = version à gauche  
L = versione sinistra a specchio

▲ en stock  
a stock

Nuance  
Leghe  
Δ 4 semaines  
4 settimane

Numéro de commande Codice prodotto	w	s	f	a	d	t <sub>max</sub>	t <sub>1</sub>	D <sub>min</sub>	HIS	Nuance Leghe		
										EG55	TI25	TN35
R108.0810.45	1	3,2	4,8	7,8	6	1,5	0,2	8	108060R	▲	▲	▲
L108.0810.45	1	3,2	4,8	7,8	6	1,5	0,2	8	108060L	▲	▲	▲
P	●	●	●	●	●	●	●	●	●	●	●	●
M	○	○	○	○	○	○	○	○	○	○	○	○
K	○	○	○	○	○	○	○	○	○	○	○	○
N	-	●	●	●	●	●	●	●	●	●	●	●
S	-	●	●	●	●	●	●	●	●	●	●	●
H	-	-	-	-	-	-	-	-	-	-	-	-



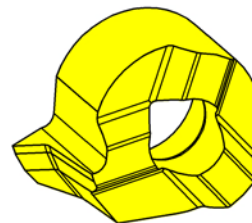
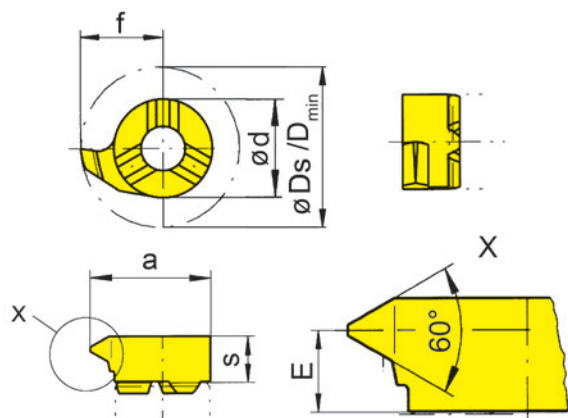

F

R = version à droite représentée  
R = versione destra come in figura

L = version à gauche  
L = versione sinistra a specchio

▲ en stock  
a stock

Nuance  
Leghe  
Δ 4 semaines  
4 settimane

Numéro de commande Codice prodotto	P	P <sub>max</sub>	E	f	a	d	s	D <sub>min</sub>	Ds	HIS	Nuance Leghe				
											EG55	TH35	TI25	TN35	
R108.0205.01	0,5	0,75	2,8	4,8	7,8	6	3,6	8	9,6	108060R	▲	▲		▲	
R108.0510.01	1	1,25	2,8	4,8	7,8	6	3,6	8	9,6	108060R	▲	▲	▲	▲	
R108.0815.01	1,5	1,75	2,6	4,8	7,8	6	3,6	8	9,6	108060R	▲	▲		▲	
L108.0205.01	0,5	0,75	2,8	4,8	7,8	6	3,6	8	9,6	108060L	▲	▲		▲	
L108.0510.01	1	1,25	2,8	4,8	7,8	6	3,6	8	9,6	108060L	▲	▲	▲	▲	
L108.0815.01	1,5	1,75	2,6	4,8	7,8	6	3,6	8	9,6	108060L	▲	▲		▲	
											P	●	●	●	●
											M	○	●	●	●
											K	○	●	●	●
											N	-	●	●	●
											S	-	●	●	●
											H	-	-	-	-

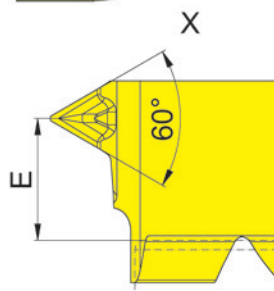
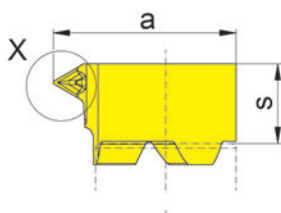
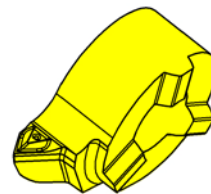
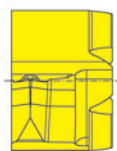
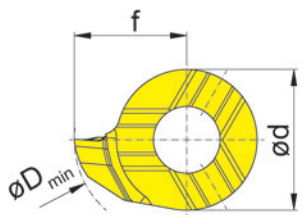

R = version à droite représentée  
R = versione destra come in figura

▲ en stock  
a stock

Nuance  
Leghe  
Δ 4 semaines  
4 settimane

Numéro de commande Codice prodotto	P	P <sub>max</sub>	E	f	a	d	s	D <sub>min</sub>	HIS	EG55
RS108.0205.GM1	0,5	0,75	2,6	4,8	7,8	6	3,4	8	108060R	▲
RS108.0510.GM1	1	1,25	2,6	4,8	7,8	6	3,4	8	108060R	▲
RS108.0815.GM1	1,5	1,5	2,6	4,8	7,8	6	3,4	8	108060R	▲
LS108.0205.GM1	0,5	0,75	2,6	4,8	7,8	6	3,4	8	108060L	▲
LS108.0510.GM1	1	1,25	2,6	4,8	7,8	6	3,4	8	108060L	▲
LS108.0815.GM1	1,5	1,5	2,6	4,8	7,8	6	3,4	8	108060L	▲
	P	●								
	M	o								
	K	o								
	N	-								
	S	-								
	H	-								



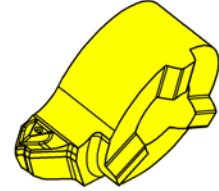
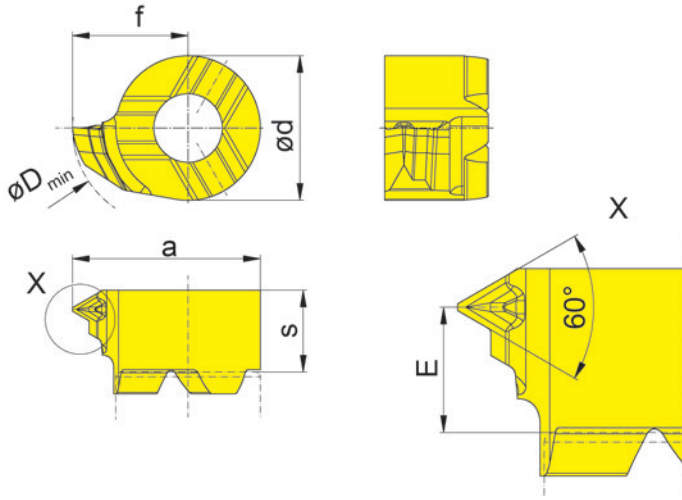

R = version à droite représentée  
R = versione destra come in figura

L = version à gauche  
L = versione sinistra a specchio

Nuance  
Leghe  
▲ en stock  
a stock  
Δ 4 semaines  
4 settimane

Numéro de commande Codice prodotto	P	E	f	a	d	s	D <sub>min</sub>	HIS	EG55
RS108.0305.GM2	0,5	2,6	4,8	7,8	6	3,4	8	108060R	▲
RS108.0510.GM2	1	2,6	4,8	7,8	6	3,4	8	108060R	▲
RS108.0512.GM2	1,25	2,6	4,8	7,8	6	3,4	8	108060R	▲
RS108.0815.GM2	1,5	2,6	4,8	7,8	6	3,4	8	108060R	▲
LS108.0305.GM2	0,5	2,6	4,8	7,8	6	3,4	8	108060L	▲
LS108.0510.GM2	1	2,6	4,8	7,8	6	3,4	8	108060L	▲
LS108.0512.GM2	1,25	2,6	4,8	7,8	6	3,4	8	108060L	▲
LS108.0815.GM2	1,5	2,6	4,8	7,8	6	3,4	8	108060L	▲
	P	●							
	M	o							
	K	o							
	N	-							
	S	-							
	H	-							

# Plaquette de coupe

## Inserto

# 108

$\varnothing \geq 8 \text{ mm}$

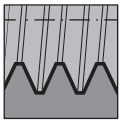

NPT  
NPTF

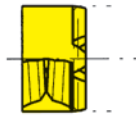
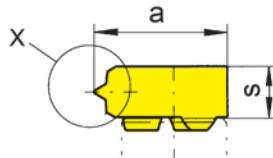
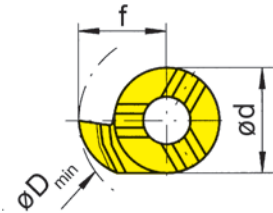

Détail X  
Dettaglio X

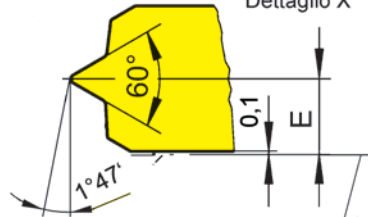

Profil frontal du porte outils  
Profilo frontale del portainsero

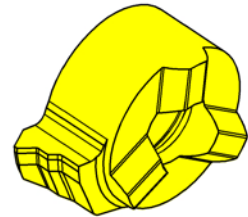

R = version à droite représentée  
R = versione destra come in figura

▲ en stock  
a stock

Nuance  
Leghe  
Δ 4 semaines  
4 settimane

Numéro de commande Codice prodotto	TPI	E	f	d	s	D <sub>min</sub>	HIS	Nuance Leghe	
								EG55	TN35
R108.NP14.02	14	1,9	4,8	6	3,6	8	108060R	▲	▲
R108.NP18.02	18	1,9	4,8	6	3,6	8	108060R	▲	▲
R108.NP27.02	27	1,9	4,8	6	3,6	8	108060R	Δ	▲
								P	● ●
								M	○ ●
								K	○ ●
								N	- ●
								S	- ●
								H	- -



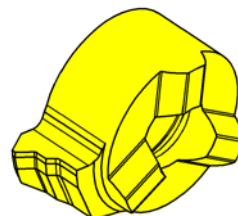
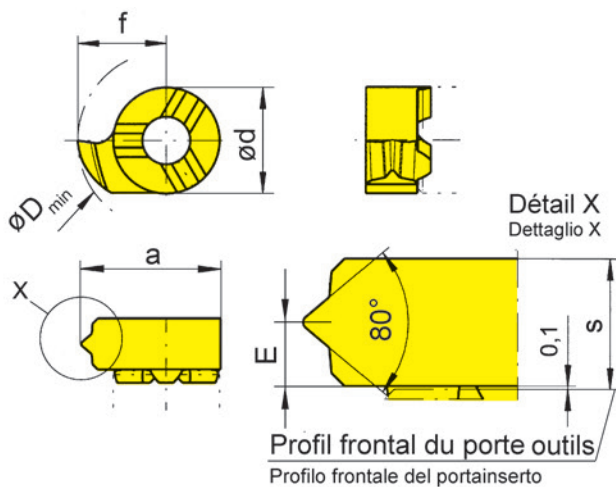

Nuance  
Leghe

▲ en stock  
a stock

Δ 4 semaines  
4 settimane

R = version à droite représentée  
R = versione destra come in figura

F

Numéro de commande Codice prodotto	TPI	E	f	d	s	D <sub>min</sub>	HIS	Nuance	
								EG55	TN35
R108.PG18.02	18	1,9	4,8	6	3,6	8	108060R	▲	▲
R108.PG20.02	20	1,9	4,8	6	3,6	8	108060R	▲	▲
								P	● ●
								M	○ ●
								K	○ ●
								N	- ●
								S	- ●
								H	- -

**10P**



**G**

**Porte outils et plaquettes**

**Portainsero e inserti**

Porte outils  
Portainsero  
B10P

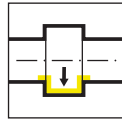

Page/Pag.  
242-243

Plaque de coupe  
Inserto  
10P/S10P

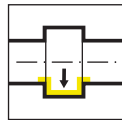

Page/Pag.  
244, 246



Page/Pag.  
245, 247

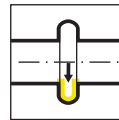

Page/Pag.  
248



Page/Pag.  
249

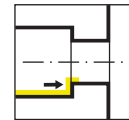

Page/Pag.  
250

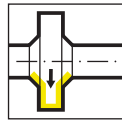

Page/Pag.  
251

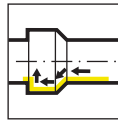

Page/Pag.  
252

Ø Alésage Foro Ø	Type de produit / Linea di prodotto												
	105	109	110	106	107	108	10P	111	11P	114	116	18P	
≥ 0,2	•												
≥ 0,5	•												
≥ 0,7	•												
≥ 1,0	•												
≥ 1,5	•												
≥ 2,0	•												
≥ 3,0	•												
≥ 4,0	•												
≥ 5,0	•												
≥ 6,0	•	•	•	•									
≥ 6,8		•	•	•									
≥ 7,0		•			•								
≥ 7,8			•		•	•							
≥ 8,0			•		•	•							
≥ 9,0			•		•	•	•						
≥ 10,0			•				•	•	•				
≥ 10,5									•				
≥ 11,0									•	•			
≥ 11,5									•				
≥ 13,8											•		
≥ 14,0											•	•	
≥ 16,0												•	
≥ 16,5											{•}		
≥ 18,0													•
Profondeur de gorge Profondità della gola	2,5	2,5	4,0	0,8	2,0	1,0	3,0	2,3	3,5	4,0 (6,5)	4,3	8,0	
Largeur de gorge Larghezza della gola	0,5- 2,0	1,0- 2,0	1,0- 3,0	0,7- 1,5	1,0- 2,0	0,7- 2,0	1,0- 3,0	0,7- 3,0	1,0- 3,0	0,7- 3,0	0,7- 4,0	2,0- 3,0	
Usinage / Operazione													
Gorge Gole	•	•	•	•	•	•	•	•	•	•	•	•	•
Alésage Alesatura	•	•	•	•	•	•		•		•	•		
Filetage Filettatura	•	•			•	•		•		•	•		
Chanfreinage Smussatura	•	•			•	•		•		•	•		
Gorge frontale Gole assiali	•	•	•							•			
Alésage et Profil Alesatura e Profilatura	•												



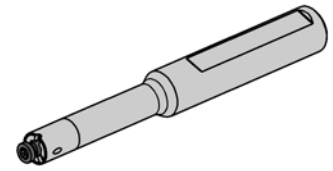
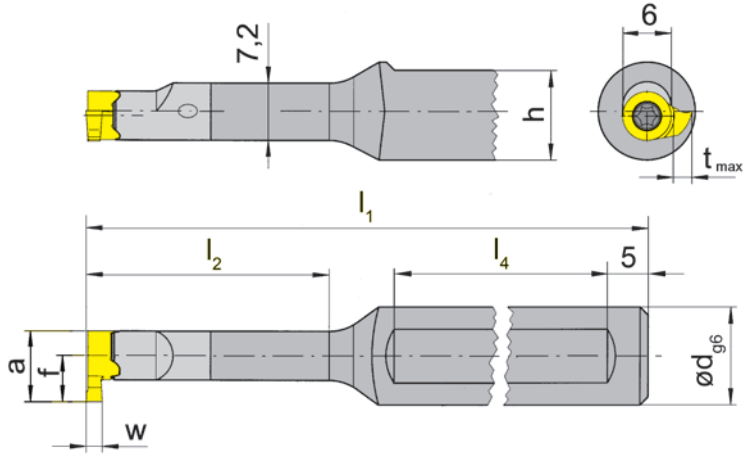
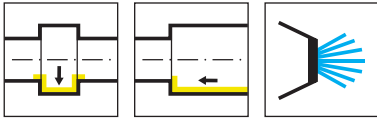

R = version à droite représentée  
R = versione destra come in figura

L = version à gauche  
L = versione sinistra a specchio

Numéro de commande Codice prodotto	d	l <sub>1</sub>	l <sub>2</sub>	h	l <sub>4</sub>	HWS
RB10P.0012.00	12	70	12,5	11	40	10P060R
RB10P.0012.01	12	80	21	11	45	10P060R
RB10P.0012.02	12	90	30	11	45	10P060R
RB10P.0012.03	12	100	42	11	45	10P060R
LB10P.0012.00	12	70	12,5	11	40	10P060L
LB10P.0012.01	12	80	21	11	45	10P060L
LB10P.0012.02	12	90	30	11	45	10P060L
LB10P.0012.03	12	100	42	11	45	10P060L

w, a, t<sub>max</sub> et f voir plaquettes  
w, a, t<sub>max</sub>, f vd. Inserti

### Pièces Détachées

Ricambi

Porte outils Portainsero	Vis de serrage Vite di serraggio	Tournevis TORX PLUS® Cacciavite TORX PLUS®
R/LB10P...	2.6.5T8EP	T8PL

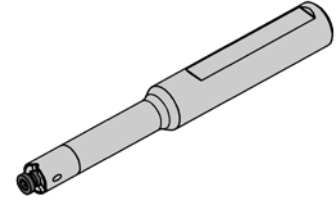
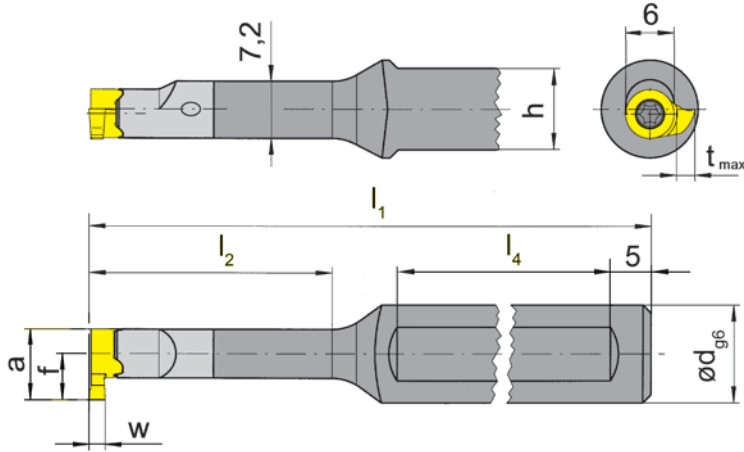
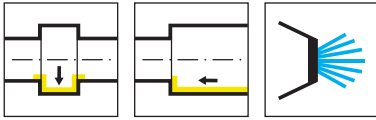

R = version à droite représentée  
R = versione destra come in figura

L = version à gauche  
L = versione sinistra a specchio

Numéro de commande Codice prodotto	d	l <sub>1</sub>	l <sub>2</sub>	h	l <sub>4</sub>	HWS
RB10P.0012.2.00	12	70	12,5	11	40	10P060R
RB10P.0012.2.01	12	80	21	11	45	10P060R
RB10P.0012.2.02	12	90	30	11	45	10P060R
RB10P.0012.2.03	12	100	42	11	45	10P060R
LB10P.0012.2.00	12	70	12,5	11	40	10P060L
LB10P.0012.2.01	12	80	21	11	45	10P060L
LB10P.0012.2.02	12	90	30	11	45	10P060L
LB10P.0012.2.03	12	100	42	11	45	10P060L

w, a, tmax et f voir plaquettes  
w, a, tmax, f vd. Inserti

### Pièces Détachées

Ricambi

Porte outils Portainsero	Vis de serrage Vite di serraggio	Tournevis TORX PLUS® Cacciavite TORX PLUS®
R/LB10P...	2.6.5T8EP	T8PL



# Plaquette de coupe

## Inserto

# 10P

$\emptyset \geq 9$  mm

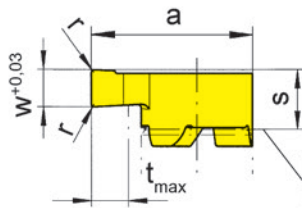
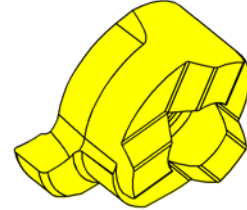
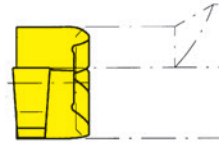
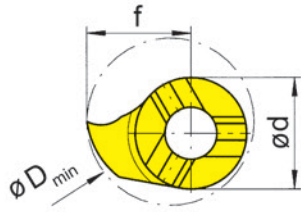
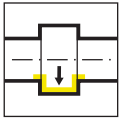

Profil frontal du porte outils  
Profilo frontale del portainsero

R = version à droite représentée  
R = versione destra come in figura

L = version à gauche  
L = versione sinistra a specchio

▲ en stock  
a stock

Nuance  
Leghe  
Δ 4 semaines  
4 settimane

Numéro de commande Codice prodotto	w	s	f	a	r	d	t <sub>max</sub>	D <sub>min</sub>	HIS	Nuance		
										EG55	TH35	
R10P.0100.1.00	1	3,6	5,5	8,5	-	6	2	9	10P060R	▲	▲	
R10P.0150.1.00	1,5	3,6	5,5	8,5	-	6	2	9	10P060R	▲	▲	
R10P.0200.1.02	2	3,6	5,5	8,5	0,2	6	2	9	10P060R	▲	▲	
R10P.0250.1.02	2,5	3,6	5,5	8,5	0,2	6	2	9	10P060R	▲	▲	
R10P.0300.1.02	3	3,6	5,5	8,5	0,2	6	2	9	10P060R	▲	▲	
L10P.0100.1.00	1	3,6	5,5	8,5	-	6	2	9	10P060L	▲	▲	
L10P.0150.1.00	1,5	3,6	5,5	8,5	-	6	2	9	10P060L	Δ	▲	
L10P.0200.1.02	2	3,6	5,5	8,5	0,2	6	2	9	10P060L	▲	▲	
L10P.0250.1.02	2,5	3,6	5,5	8,5	0,2	6	2	9	10P060L	Δ	▲	
L10P.0300.1.02	3	3,6	5,5	8,5	0,2	6	2	9	10P060L	Δ	▲	
										P	●	●
										M	○	●
										K	○	●
										N	-	●
										S	-	●
										H	-	-

G

# Plaquette de coupe

## Inserto

# S10P

$\varnothing \geq 9$  mm

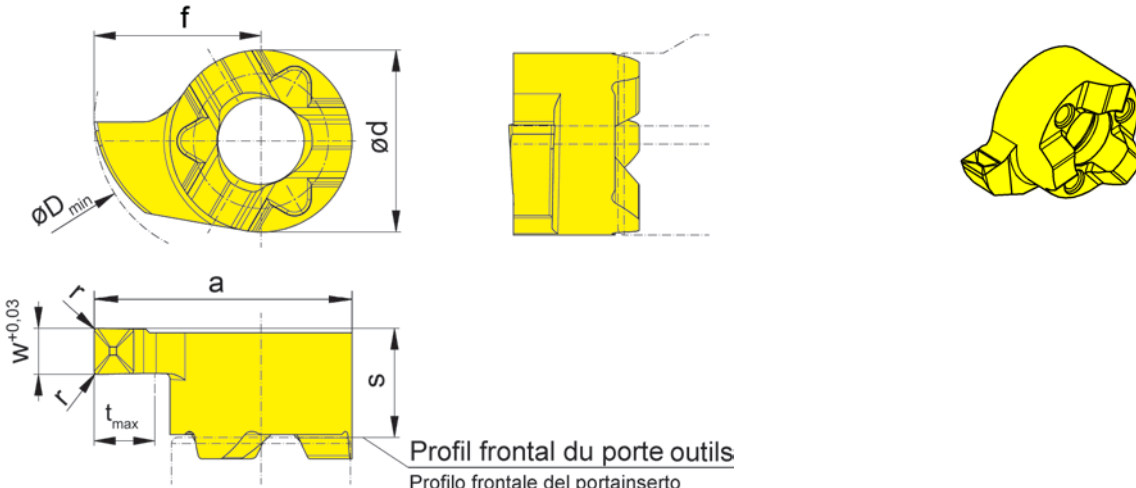
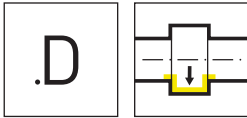

R = version à droite représentée  
R = versione destra come in figura

L = version à gauche  
L = versione sinistra a specchio

▲ en stock  
a stock

Nuance  
Leghe  
Δ 4 semaines  
4 settimane

Numéro de commande Codice prodotto	w	s	f	a	r	d	t <sub>max</sub>	D <sub>min</sub>	HIS	EG55	TH35
RS10P.0100.1.D1	1	3,6	5,5	8,5	0,1	6	2	9	10P060R	▲	▲
RS10P.0150.1.D1	1,5	3,6	5,5	8,5	0,1	6	2	9	10P060R	▲	▲
RS10P.0200.1.D2	2	3,6	5,5	8,5	0,2	6	2	9	10P060R	▲	▲
LS10P.0100.1.D1	1	3,6	5,5	8,5	0,1	6	2	9	10P060L	Δ	▲
LS10P.0150.1.D1	1,5	3,6	5,5	8,5	0,1	6	2	9	10P060L	Δ	▲
LS10P.0200.1.D2	2	3,6	5,5	8,5	0,2	6	2	9	10P060L	Δ	Δ
										P ● ●	
										M ○ ●	
										K ○ ●	
										N - ●	
										S - ●	
										H - -	



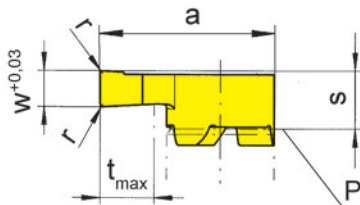
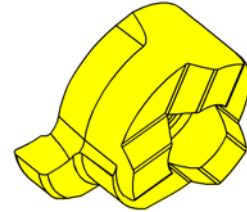
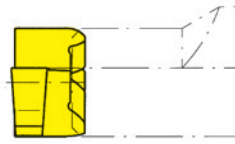
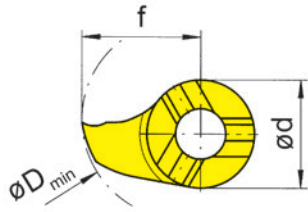
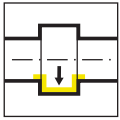

Profil frontal du porte outils  
Profilo frontale del portainsero

R = version à droite représentée  
R = versione destra come in figura

L = version à gauche  
L = versione sinistra a specchio

▲ en stock  
a stock

Nuance  
Leghe  
Δ 4 semaines  
4 settimane

Numéro de commande Codice prodotto	w	s	f	a	r	d	t <sub>max</sub>	D <sub>min</sub>	HIS	Nuance Leghe	
										EG55	TH35
R10P.0100.2.00	1	3,6	6,5	9,5	-	6	3	10	10P060R	▲	▲
R10P.0150.2.00	1,5	3,6	6,5	9,5	-	6	3	10	10P060R	▲	▲
R10P.0200.2.02	2	3,6	6,5	9,5	0,2	6	3	10	10P060R	▲	▲
L10P.0100.2.00	1	3,6	6,5	9,5	-	6	3	10	10P060L	Δ	▲
L10P.0150.2.00	1,5	3,6	6,5	9,5	-	6	3	10	10P060L		▲
L10P.0200.2.02	2	3,6	6,5	9,5	0,2	6	3	10	10P060L	▲	▲
										P	●
										M	○
										K	○
										N	-
										S	-
										H	-

# Plaquette de coupe

Inserto

# S10P

$\varnothing \geq 10 \text{ mm}$

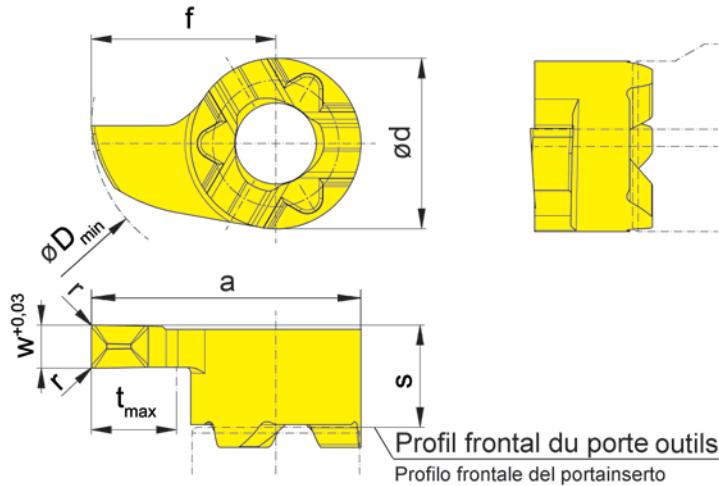
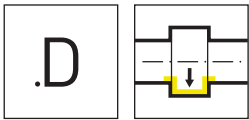

R = version à droite représentée  
R = versione destra come in figura

L = version à gauche  
L = versione sinistra a specchio

▲ en stock  
a stock

Nuance  
Leghe  
Δ 4 semaines  
4 settimane

Numéro de commande Codice prodotto	w	s	f	a	r	d	t <sub>max</sub>	D <sub>min</sub>	HIS	Nuance Leghe		
										EG55	TH35	
RS10P.0150.2.D1	1,5	3,6	6,5	9,5	0,1	6	3	10	10P060R	▲	▲	
RS10P.0200.2.D2	2	3,6	6,5	9,5	0,2	6	3	10	10P060R	▲	▲	
LS10P.0150.2.D1	1,5	3,6	6,5	9,5	0,1	6	3	10	10P060L	Δ	▲	
LS10P.0200.2.D2	2	3,6	6,5	9,5	0,2	6	3	10	10P060L	▲	▲	
										P	●	●
										M	○	●
										K	○	●
										N	-	●
										S	-	●
										H	-	-



# Plaquette de coupe

Inserto

# 10P

$\varnothing \geq 10 \text{ mm}$

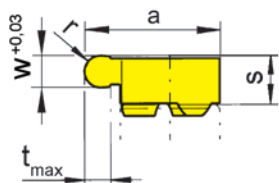
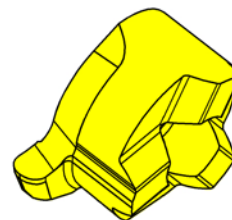
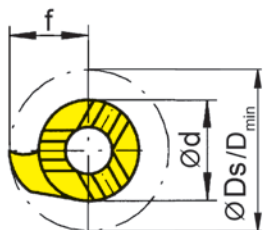
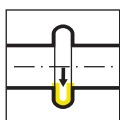

R = version à droite représentée  
R = versione destra come in figura

L = version à gauche  
L = versione sinistra a specchio

▲ en stock  
a stock

Nuance  
Leghe  
Δ 4 semaines  
4 settimane

Numéro de commande Codice prodotto	w	s	f	a	r	d	t <sub>max</sub>	D <sub>min</sub>	HIS	EG55
R10P.0005.2.10	1	3,6	6,5	9,5	0,5	6	3	10	10P060R	▲
R10P.0007.2.15	1,5	3,6	6,5	9,5	0,76	6	3	10	10P060R	▲
R10P.0009.2.18	1,8	3,6	6,5	9,5	0,9	6	3	10	10P060R	▲
L10P.0005.2.10	1	3,6	6,5	9,5	0,5	6	3	10	10P060L	▲
L10P.0007.2.15	1,5	3,6	6,5	9,5	0,76	6	3	10	10P060L	▲
L10P.0009.2.18	1,8	3,6	6,5	9,5	0,9	6	3	10	10P060L	▲
									P ●	
									M ○	
									K ○	
									N -	
									S -	
									H -	

G

# Plaquette de coupe

Inserto

# S10P

$\varnothing \geq 8,8 \text{ mm}$

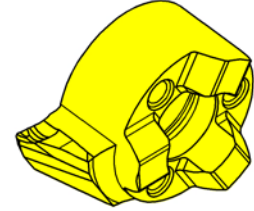
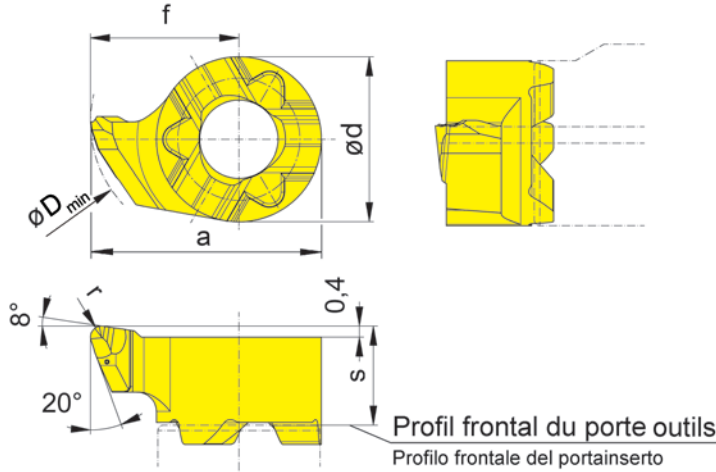
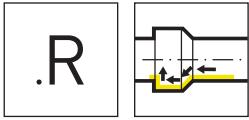

R = version à droite représentée  
R = versione destra come in figura

L = version à gauche  
L = versione sinistra a specchio

▲ en stock  
a stock

Nuance  
Leghe  
Δ 4 semaines  
4 settimane

Numéro de commande Codice prodotto	s	f	a	r	d	D <sub>min</sub>	HIS	Nuance Leghe	
								EG55	TH35
RS10P.1854.R2	3,6	5,4	8,4	0,2	6	8,8	10P060R	▲	▲
RS10P.1854.R4	3,6	5,4	8,4	0,4	6	8,8	10P060R	▲	▲
LS10P.1854.R2	3,6	5,4	8,4	0,2	6	8,8	10P060L	▲	▲
LS10P.1854.R4	3,6	5,4	8,4	0,4	6	8,8	10P060L	Δ	▲
								P	● ●
								M	○ ●
								K	○ ●
								N	- ●
								S	- ●
								H	- -



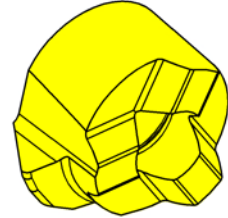
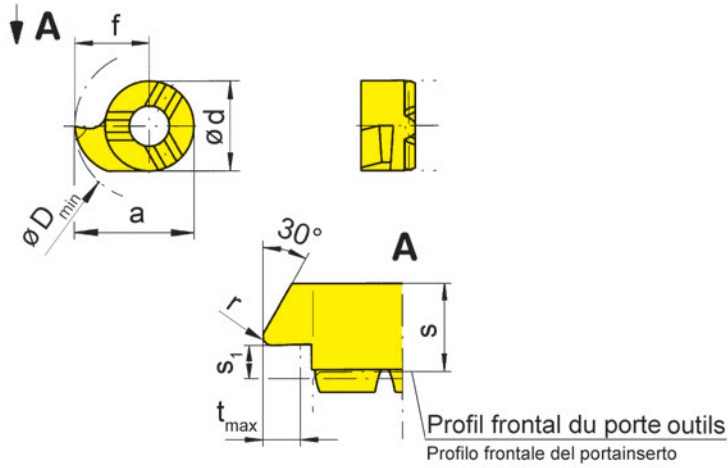
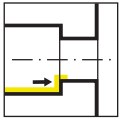

R = version à droite représentée  
R = versione destra come in figura

L = version à gauche  
L = versione sinistra a specchio

▲ en stock  
a stock

Nuance  
Leghe  
Δ 4 semaines  
4 settimane

Numéro de commande Codice prodotto	s	f	a	r	s <sub>1</sub>	d	t <sub>max</sub>	D <sub>min</sub>	HIS	EG55
R10P.3065.2.02	3,75	6,5	9,5	0,2	1	6	3	10	10P060R	▲
L10P.3065.2.02	3,75	6,5	9,5	0,2	1	6	3	10	10P060L	▲
										P ●
										M ○
										K ○
										N -
										S -
										H -

# Plaquette de coupe

## Inserto

# 10P

$\varnothing \geq 9$  mm

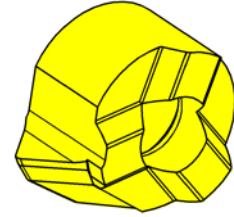
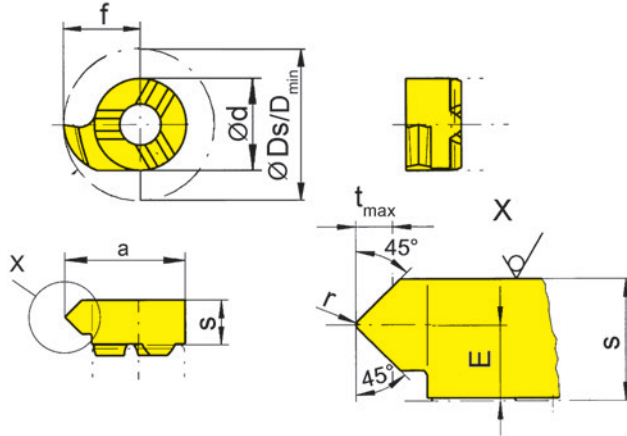
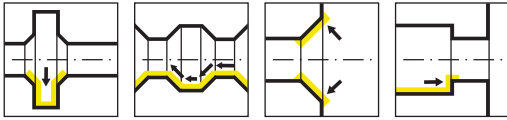

R = version à droite représentée  
R = versione destra come in figura

L = version à gauche  
L = versione sinistra a specchio

Nuance  
Leghe  
▲ en stock  
a stock  
Δ 4 semaines  
4 settimane

Numéro de commande Codice prodotto	E	f	r	d	s	a	D <sub>min</sub>	α	t <sub>max</sub>	HIS	EG55
<b>R10P.4545.1.02</b>	1,9	5,5	0,2	6	3,75	8,5	9	45°	1,5	10P060R	▲
<b>L10P.4545.1.02</b>	1,9	5,5	0,2	6	3,75	8,5	9	45°	1,5	10P060L	▲
											P ●
											M ○
											K ○
											N -
											S -
											H -



# Plaquette de coupe Inserto

# 10P

$\varnothing \geq 10 \text{ mm}$

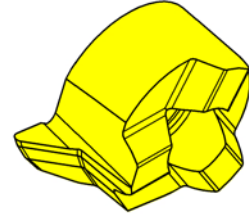
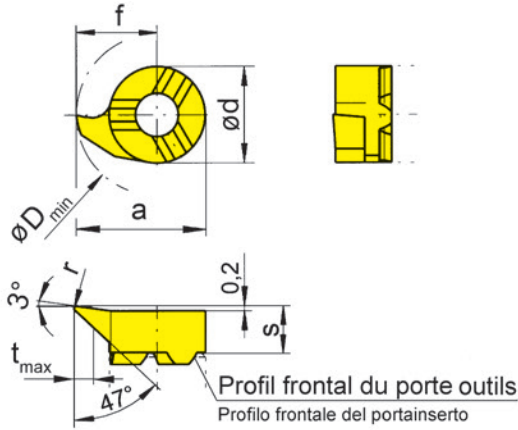
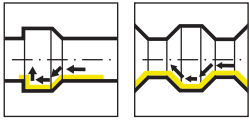

R = version à droite représentée  
R = versione destra come in figura

L = version à gauche  
L = versione sinistra a specchio

▲ en stock  
a stock

Nuance  
Leghe  
Δ 4 semaines  
4 settimane

Numéro de commande Codice prodotto	s	f	a	r	d	t <sub>max</sub>	D <sub>min</sub>	HIS	EG55
<b>R10P.4765.2.02</b>	3,6	6,5	9,5	0,2	6	3	10	10P060R	▲
<b>L10P.4765.2.02</b>	3,6	6,5	9,5	0,2	6	3	10	10P060L	▲
									P ●
									M ○
									K ○
									N -
									S -
									H -

G

**111**



**H**

**Porte outils et plaquettes**

**Portainsero e inserti**

Porte outils  
Portainsero  
B111

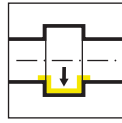

Page/Pag.  
256-257

Plaque de coupe  
Inserto  
111/S111



Page/Pag.  
258-259

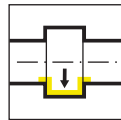

Page/Pag.  
260



Page/Pag.  
261

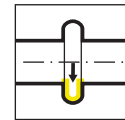

Page/Pag.  
262

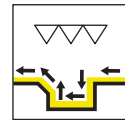

Page/Pag.  
263



Page/Pag.  
264

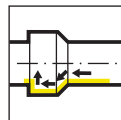

Page/Pag.  
265, 268-269



Page/Pag.  
266

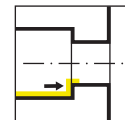

Page/Pag.  
267

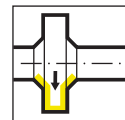

Page/Pag.  
270

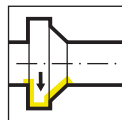

Page/Pag.  
271

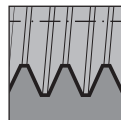

Page/Pag.  
272-277

Ø Alésage Foro Ø	Type de produit / Linea di prodotto											
	105	109	110	106	107	108	10P	111	11P	114	116	18P
≥ 0,2	•											
≥ 0,5	•											
≥ 0,7	•											
≥ 1,0	•											
≥ 1,5	•											
≥ 2,0	•											
≥ 3,0	•											
≥ 4,0	•											
≥ 5,0	•											
≥ 6,0	•	•	•	•								
≥ 6,8		•	•	•								
≥ 7,0		•			•							
≥ 7,8			•		•	•						
≥ 8,0			•		•	•						
≥ 9,0			•		•	•	•					
≥ 10,0			•				•	•	•			
≥ 10,5									•			
≥ 11,0								•	•			
≥ 11,5									•			
≥ 13,8										•		
≥ 14,0										•	•	
≥ 16,0											•	
≥ 16,5										{•}		
≥ 18,0												•
Profondeur de gorge Profondità della gola	2,5	2,5	4,0	0,8	2,0	1,0	3,0	2,3	3,5	4,0 (6,5)	4,3	8,0
Largeur de gorge Larghezza della gola	0,5- 2,0	1,0- 2,0	1,0- 3,0	0,7- 1,5	1,0- 2,0	0,7- 2,0	1,0- 3,0	0,7- 3,0	1,0- 3,0	0,7- 3,0	0,7- 4,0	2,0- 3,0
Usinage / Operazione												
Gorge Gole	•	•	•	•	•	•	•	•	•	•	•	•
Alésage Alesatura	•	•	•	•	•	•		•		•	•	
Filetage Filettatura	•	•			•	•		•		•	•	
Chanfreinage Smussatura	•	•			•	•		•		•	•	
Gorge frontale Gole assiali	•	•	•							•		
Alésage et Profil Alesatura e Profilatura	•											

H

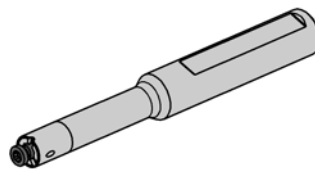
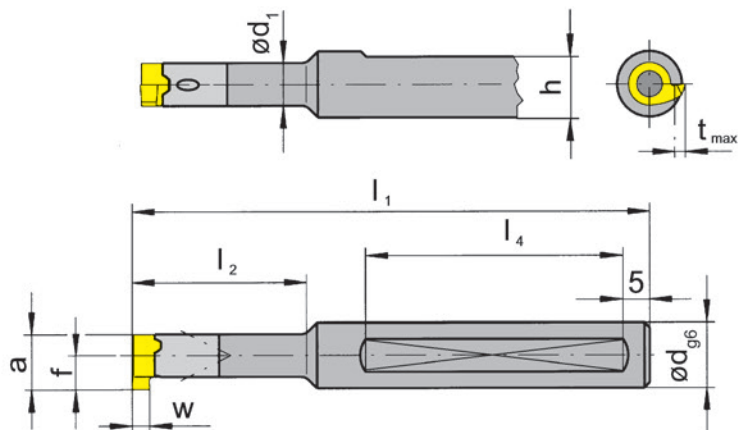
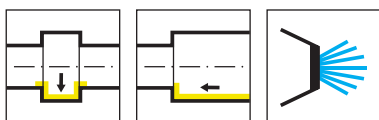

Illustration de coupe à droite représentée

Figura = taglio destro

Numéro de commande Codice prodotto	d	$l_1$	$l_2$	h	$l_4$	$d_1$	HWS
<b>B111.0008.01A</b>	8	80	-	-	-	-	111080R • 111080L
<b>B111.0008.01</b>	8	80	-	7	55	8	111080R • 111080L
<b>B111.0012.00</b>	12	75	16,5	11	40	8	111080R • 111080L
<b>B111.0012.01</b>	12	95	29	11	50	8	111080R • 111080L
<b>B111.0012.02</b>	12	110	42	11	50	8	111080R • 111080L
<b>B111.0012.03</b>	12	120	56	11	50	8	111080R • 111080L

w, a, tmax et f voir plaquettes

w, a, tmax, f vd. Inserti

H

### Pièces Détachées

Ricambi

Porte outils Portainsero	Vis de serrage Vite di serraggio	Tournevis TORX PLUS® Cacciavite TORX PLUS®
B111...	<b>3.5.12T10EP</b>	<b>T10PL</b>

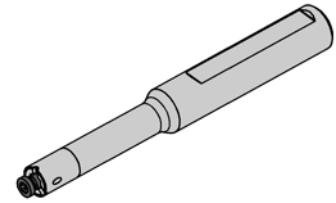
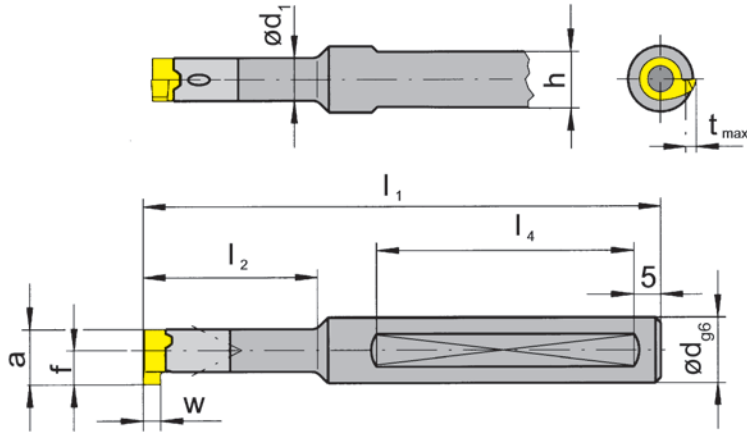
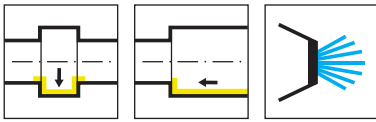

R = version à droite représentée

R = versione destra come in figura

Numéro de commande Codice prodotto	d	$l_1$	$l_2$	h	$l_4$	$d_1$	HWS
<b>B111.0012.2.00</b>	12	75	16,5	11	40	8	111080R • 111080L
<b>B111.0012.2.01</b>	12	95	29	11	50	8	111080R • 111080L
<b>B111.0012.2.02</b>	12	110	42	11	50	8	111080R • 111080L
<b>B111.0012.2.03</b>	12	120	56	11	50	8	111080R • 111080L

w, a, tmax et f voir plaquettes  
w, a, tmax, f vd. Inserti

### Pièces Détachées

Ricambi

Porte outils Portainsero	Vis de serrage Vite di serraggio	Tournevis TORX PLUS® Cacciavite TORX PLUS®
B111...	<b>3.5.12T10EP</b>	<b>T10PL</b>

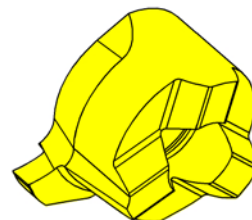
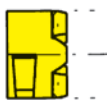
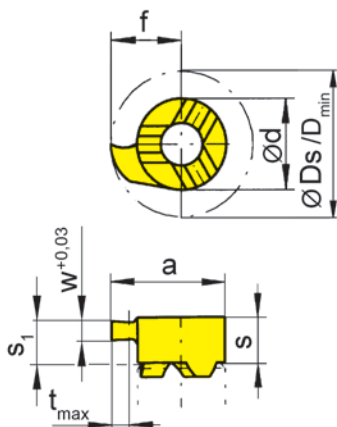
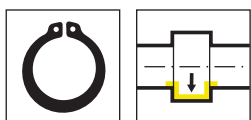

R = version à droite représentée  
R = versione destra come in figura

L = version à gauche  
L = versione sinistra a specchio

▲ en stock  
a stock

Nuance  
Leghe  
Δ 4 semaines  
4 settimane

Numéro de commande Codice prodotto	w	Nw	f	Ds	d	s	s <sub>1</sub>	a	t <sub>max</sub>	D <sub>min</sub>	Z	HIS	Nuance Leghe			
													EG55	TH35	TN35	
R111.0070.00	0,74	0,7	6,7	13,4	8	4,15	3,95	10,7	1,2	11	1	111080R	▲	▲	▲	
R111.0080.00	0,84	0,8	6,7	13,4	8	4,15	3,95	10,7	1,3	11	1	111080R	▲	▲	▲	
R111.0090.00	0,94	0,9	6,7	13,4	8	4,15	3,95	10,7	1,5	11	1	111080R	▲	▲	▲	
L111.0070.00	0,74	0,7	6,7	13,4	8	4,15	3,95	10,7	1,2	11	1	111080L		Δ	▲	
L111.0080.00	0,84	0,8	6,7	13,4	8	4,15	3,95	10,7	1,3	11	1	111080L		Δ	▲	
L111.0090.00	0,94	0,9	6,7	13,4	8	4,15	3,95	10,7	1,5	11	1	111080L		▲	▲	
													P	●	●	●
													M	○	●	●
													K	○	●	●
													N	-	●	●
													S	-	●	●
													H	-	-	-

Profondeur de coupe limitée  
Profondità di taglio limitata

Largeurs pour gorges circlips DIN 471/472  
Larghezza per esecuzione anelli Seeger DIN 471/472

# Plaquette de coupe

## Inserto

# 111

$\varnothing \geq 11 \text{ mm}$

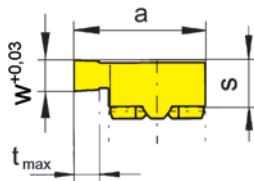
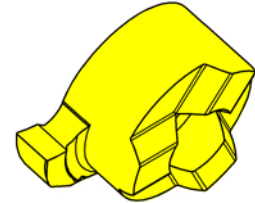
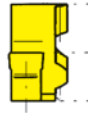
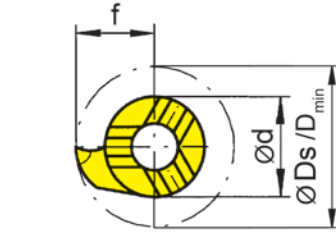
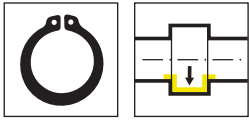

R = version à droite représentée  
R = versione destra come in figura

L = version à gauche  
L = versione sinistra a specchio

▲ en stock  
a stock

Nuance  
Leghe  
Δ 4 semaines  
4 settimane

Numéro de commande Codice prodotto	w	Nw	s	f	Ds	d	a	t <sub>max</sub>	D <sub>min</sub>	Z	HIS	Nuance Leghe			
												EG55	TH35	TN35	
<b>R111.0110.00</b>	1,19	1,1	3,95	6,7	13,4	8	10,7	2,3	11	1	111080R	▲	▲	▲	
<b>R111.0130.00</b>	1,39	1,3	3,95	6,7	13,4	8	10,7	2,3	11	1	111080R	▲	▲	▲	
<b>R111.0160.00</b>	1,69	1,6	3,95	6,7	13,4	8	10,7	2,3	11	1	111080R	▲	▲	▲	
<b>L111.0110.00</b>	1,19	1,1	3,95	6,7	13,4	8	10,7	2,3	11	1	111080L	▲	▲	▲	
<b>L111.0130.00</b>	1,39	1,3	3,95	6,7	13,4	8	10,7	2,3	11	1	111080L	Δ	▲	▲	
<b>L111.0160.00</b>	1,69	1,6	3,95	6,7	13,4	8	10,7	2,3	11	1	111080L	▲	▲	▲	
Largeurs pour gorges circlips DIN 471/472 Larghezza per esecuzione anelli Seeger DIN 471/472												P	●	●	●
												M	○	●	●
												K	○	●	●
												N	-	●	●
												S	-	●	●
												H	-	-	-



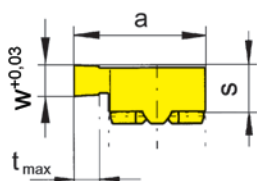
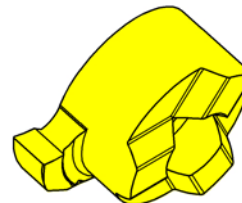
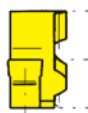
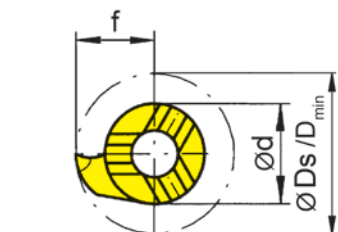
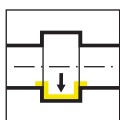

R = version à droite représentée  
R = versione destra come in figura

L = version à gauche  
L = versione sinistra a specchio

▲ en stock  
a stock

Nuance  
Leghe  
Δ 4 semaines  
4 settimane

Numéro de commande Codice prodotto	w	s	f	Ds	d	a	t <sub>max</sub>	D <sub>min</sub>	Z	HIS	Nuance Leghe		
											EG55	TH35	TN35
R111.0100.1.00	1	3,95	6,7	13,4	8	10,7	2,3	11	1	111080R	Δ		▲
R111.0150.00	1,5	3,95	6,7	13,4	8	10,7	2,3	11	1	111080R	▲	▲	▲
R111.0200.00	2	3,95	6,7	13,4	8	10,7	2,3	11	1	111080R	▲	▲	▲
R111.0250.00	2,5	3,95	6,7	13,4	8	10,7	2,3	11	1	111080R	▲	▲	▲
R111.0300.00	3	3,95	6,7	13,4	8	10,7	2,3	11	1	111080R	▲	▲	▲
L111.0100.1.00	1	3,95	6,7	13,4	8	10,7	2,3	11	1	111080L	Δ		▲
L111.0150.00	1,5	3,95	6,7	13,4	8	10,7	2,3	11	1	111080L	▲	▲	▲
L111.0200.00	2	3,95	6,7	13,4	8	10,7	2,3	11	1	111080L	▲	▲	▲
L111.0250.00	2,5	3,95	6,7	13,4	8	10,7	2,3	11	1	111080L	▲	▲	▲
L111.0300.00	3	3,95	6,7	13,4	8	10,7	2,3	11	1	111080L	▲	▲	▲
P											●	●	●
M											○	●	●
K											○	●	●
N											-	●	●
S											-	●	●
H											-	-	-

# Plaquette de coupe

## Inserto

# S111

$\emptyset \geq 11 \text{ mm}$

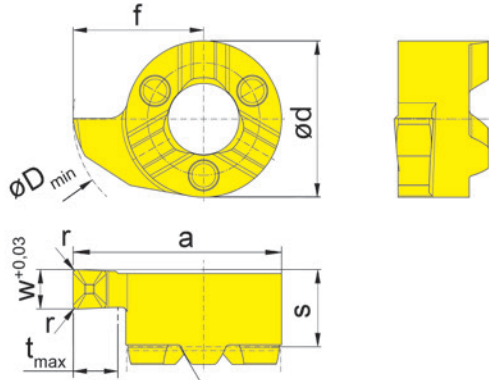
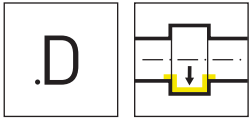

Profil frontal du porte outils  
 Profilo frontale del portainsero

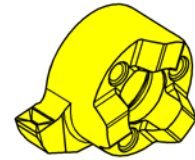

R = version à droite représentée  
 R = versione destra come in figura

L = version à gauche  
 L = versione sinistra a specchio

▲ en stock  
 a stock

Nuance  
 Leghe  
 Δ 4 semaines  
 4 settimane

Numéro de commande Codice prodotto	w	s	f	a	r	d	t <sub>max</sub>	D <sub>min</sub>	HIS	Nuance Leghe	
										EG55	TH35
RS111.0150.D1	1,5	3,95	6,7	10,7	0,1	8	2,3	11	111080R	▲	▲
RS111.0200.D2	2	3,95	6,7	10,7	0,2	8	2,3	11	111080R	▲	▲
RS111.0250.D2	2,5	3,95	6,7	10,7	0,2	8	2,3	11	111080R	▲	▲
LS111.0150.D1	1,5	3,95	6,7	10,7	0,1	8	2,3	11	111080L	Δ	▲
LS111.0200.D2	2	3,95	6,7	10,7	0,2	8	2,3	11	111080L	▲	▲
LS111.0250.D2	2,5	3,95	6,7	10,7	0,2	8	2,3	11	111080L	Δ	▲
										P	●
										M	○
										K	○
										N	-
										S	-
										H	-



# Plaquette de coupe

## Inserto

# 111

$\varnothing \geq 11 \text{ mm}$

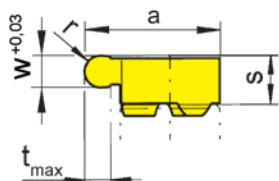
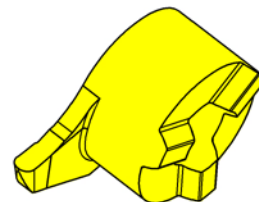
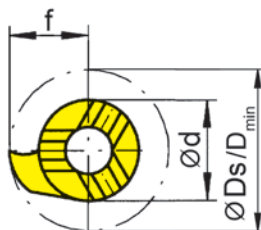
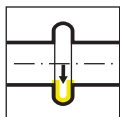

R = version à droite représentée  
R = versione destra come in figura

L = version à gauche  
L = versione sinistra a specchio

▲ en stock  
a stock

Nuance  
Leghe  
Δ 4 semaines  
4 settimane

Numéro de commande Codice prodotto	w	f	Ds	r	d	s	a	t <sub>max</sub>	D <sub>min</sub>	Z	HIS	Nuance / Leghe		
												EG55	TH35	TN35
<b>R111.0004.08</b>	0,8	6,7	13,4	0,4	8	3,95	10,7	2,3	11	1	111080R	▲	▲	▲
<b>R111.0006.12</b>	1,2	6,7	13,4	0,6	8	3,95	10,7	2,3	11	1	111080R	▲	▲	▲
<b>R111.0009.18</b>	1,8	6,7	13,4	0,9	8	3,95	10,7	2,3	11	1	111080R	▲	▲	▲
<b>R111.0010.20</b>	2	6,7	13,4	1	8	3,95	10,7	2,3	11	1	111080R	▲	▲	▲
<b>R111.0015.30</b>	3	6,7	13,4	1,5	8	3,95	10,7	2,3	11	1	111080R	▲	▲	▲
<b>L111.0004.08</b>	0,8	6,7	13,4	0,4	8	3,95	10,7	2,3	11	1	111080L	▲	▲	▲
<b>L111.0006.12</b>	1,2	6,7	13,4	0,6	8	3,95	10,7	2,3	11	1	111080L	▲	▲	▲
<b>L111.0009.18</b>	1,8	6,7	13,4	0,9	8	3,95	10,7	2,3	11	1	111080L	▲	▲	▲
<b>L111.0010.20</b>	2	6,7	13,4	1	8	3,95	10,7	2,3	11	1	111080L	▲	▲	▲
<b>L111.0015.30</b>	3	6,7	13,4	1,5	8	3,95	10,7	2,3	11	1	111080L	▲	▲	▲
<b>P</b>												●	●	●
<b>M</b>												○	●	●
<b>K</b>												○	●	●
<b>N</b>												-	●	●
<b>S</b>												-	●	●
<b>H</b>												-	-	-

H

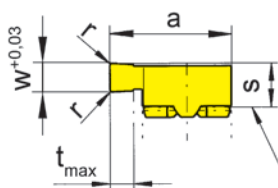
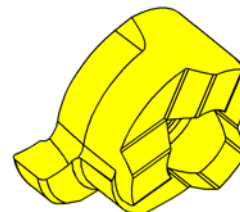
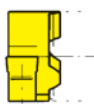
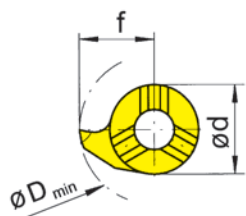
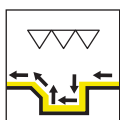

Profil frontal du porte outils  
Profilo frontale del portainsero

R = version à droite représentée  
R = versione destra come in figura

L = version à gauche  
L = versione sinistra a specchio

▲ en stock  
a stock

Nuance  
Leghe  
Δ 4 semaines  
4 settimane

Numéro de commande Codice prodotto	w	s	f	a	r	d	t <sub>max</sub>	D <sub>min</sub>	HIS	Nuance Leghe			
										EG55	TH35	TI25	TN35
R111.0200.02	2	3,95	6,7	10,7	0,2	8	2,3	11	111080R	▲	▲	▲	▲
L111.0200.02	2	3,95	6,7	10,7	0,2	8	2,3	11	111080L	▲	▲	Δ	▲
P	●	●	●	●	●	●	●	●		●	●	●	●
M	○	●	●	●	●	●	●	●		○	●	●	●
K	○	●	●	●	●	●	●	●		○	●	●	●
N	-	●	●	●	●	●	●	●		-	●	●	●
S	-	●	●	●	●	●	●	●		-	●	●	●
H	-	-	-	-	-	-	-	-		-	-	-	-

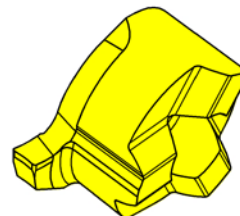
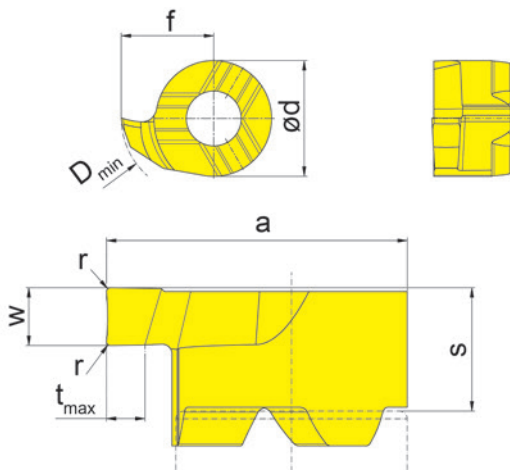
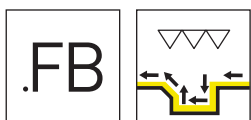

R = version à droite représentée  
R = versione destra come in figura

L = version à gauche  
L = versione sinistra a specchio

▲ en stock  
a stock

Nuance  
Leghe  
Δ 4 semaines  
4 settimane

Numéro de commande Codice prodotto	w	s	f	a	r	d	t <sub>max</sub>	D <sub>min</sub>	HIS	EG35
R111.FB10.01	1	3,95	6,7	10,7	0,1	8	2,3	11	111080R	▲
R111.FB15.01	1,5	3,95	6,7	10,7	0,1	8	2,3	11	111080R	▲
L111.FB10.01	1	3,95	6,7	10,7	0,1	8	2,3	11	111080L	▲
L111.FB15.01	1,5	3,95	6,7	10,7	0,1	8	2,3	11	111080L	▲

P	●
M	●
K	○
N	-
S	-
H	-

Calcul de la plus petite largeur de gorge possible  $w_x$   
Calcolo della larghezza di gola  $w_x$  più basso possibile

Exemple R111.FB10.01  
Esempio

$w_x = 2 \times$  Largeur de gorge  $w - 2 \times$  Rayon d'angles plaquette  $r$

$w_x = 2 \times$  Larghezza della gola  $w - 2 \times$  Spigolo raggiato inserto  $r$

$w_x = 2 \times 1$  mm -  $2 \times 0,1$  mm

$w_x = 1,8$  mm

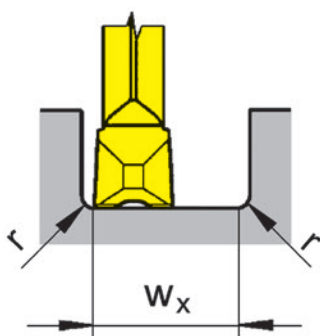

Déroulement du processus  
Percorso di lavoro

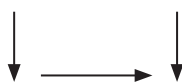

# Plaquette de coupe

Inserto

# 111

$\varnothing \geq 9,8 \text{ mm}$

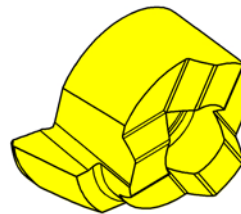
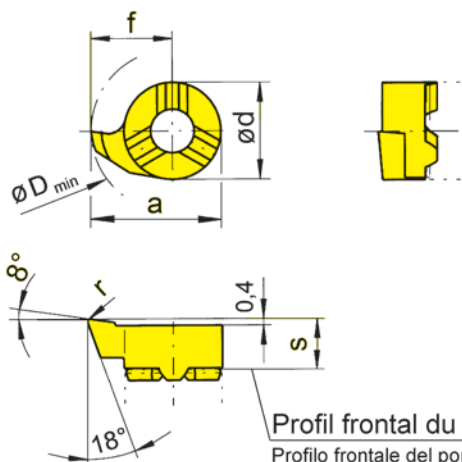
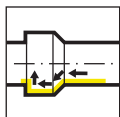

R = version à droite représentée  
R = versione destra come in figura

L = version à gauche  
L = versione sinistra a specchio

▲ en stock  
a stock

Nuance  
Leghe  
Δ 4 semaines  
4 settimane

Numéro de commande Codice prodotto	s	f	a	r	d	D <sub>min</sub>	HIS	Nuance / Leghe			
								EG55	TH35	TI25	TN35
<b>R111.1855.02</b>	3,95	5,5	9,5	0,2	8	9,8	111080R	▲	▲	▲	▲
<b>R111.1867.02</b>	3,95	6,7	10,7	0,2	8	11	111080R	▲	▲	▲	▲
<b>L111.1855.02</b>	3,95	5,5	9,5	0,2	8	9,8	111080L	▲	▲	▲	▲
<b>L111.1867.02</b>	3,95	6,7	10,7	0,2	8	11	111080L	▲	▲	▲	▲
<b>P</b>	●	●	●	●	●	●					
<b>M</b>	○	●	●	●	●	●					
<b>K</b>	○	●	●	●	●	●					
<b>N</b>	-	●	●	●	●	●					
<b>S</b>	-	●	●	●	●	●					
<b>H</b>	-	-	-	-	-	-					



**Plaque de coupe**  
Inserto

**S111**  $\varnothing \geq 11$  mm

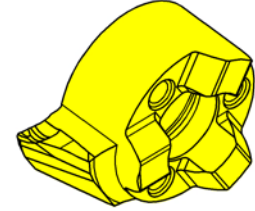
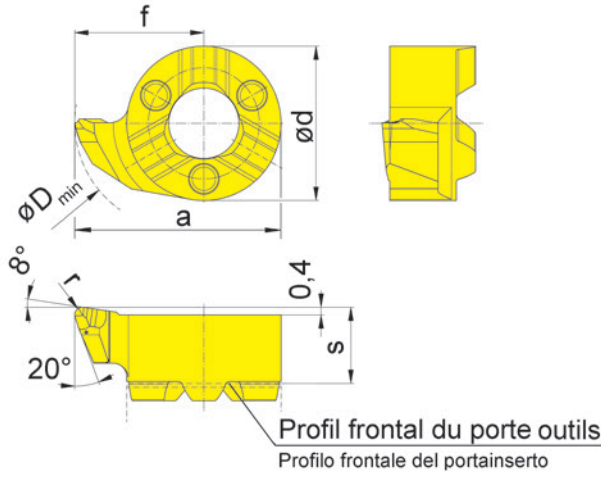

R = version à droite représentée  
R = versione destra come in figura

L = version à gauche  
L = versione sinistra a specchio

▲ en stock  
a stock

Nuance  
Leghe  
Δ 4 semaines  
4 settimane

Numéro de commande Codice prodotto	s	f	a	r	d	D <sub>min</sub>	HIS	Nuance Leghe	
								EG55	TH35
RS111.1867.R2	3,95	6,7	10,7	0,2	8	11	111080R	▲	▲
RS111.1867.R4	3,95	6,7	10,7	0,4	8	11	111080R	▲	▲
LS111.1867.R2	3,95	6,7	10,7	0,2	8	11	111080L	▲	▲
LS111.1867.R4	3,95	6,7	10,7	0,4	8	11	111080L	▲	▲
								P	● ●
								M	○ ●
								K	○ ●
								N	- ●
								S	- ●
								H	- -

H

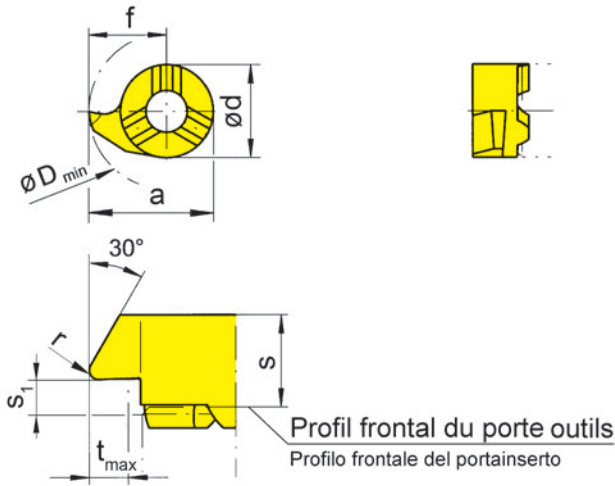
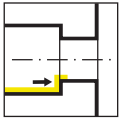

R = version à droite représentée  
R = versione destra come in figura

L = version à gauche  
L = versione sinistra a specchio

▲ en stock  
a stock

Nuance  
Leghe  
Δ 4 semaines  
4 settimane

Numéro de commande Codice prodotto	s	f	a	r	s <sub>1</sub>	d	t <sub>max</sub>	D <sub>min</sub>	HIS	Nuance Leghe			
										EG55	TH35	TN35	
<b>R111.3067.02</b>	4,15	6,7	10,7	0,2	1,4	8	2,3	11	111080R	▲	▲	▲	
<b>R111.3067.04</b>	4,15	6,7	10,7	0,4	1,4	8	2,3	11	111080R	Δ	▲	Δ	
<b>L111.3067.02</b>	4,15	6,7	10,7	0,2	1,4	8	2,3	11	111080L	▲	▲	▲	
<b>L111.3067.04</b>	4,15	6,7	10,7	0,4	1,4	8	2,3	11	111080L	Δ	Δ	▲	
										P	●	●	●
										M	○	●	●
										K	○	●	●
										N	-	●	●
										S	-	●	●
										H	-	-	-



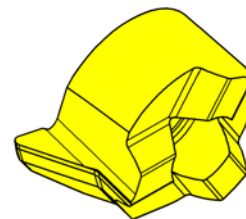
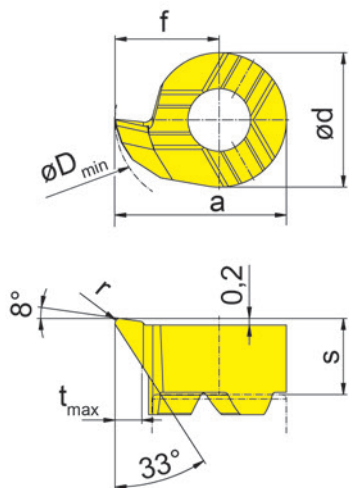
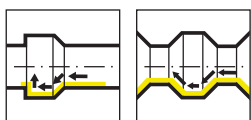

R = version à droite représentée  
R = versione destra come in figura

L = version à gauche  
L = versione sinistra a specchio

▲ en stock  
a stock

Nuance  
Leghe  
Δ 4 semaines  
4 settimane

Numéro de commande Codice prodotto	s	f	a	r	d	t <sub>max</sub>	D <sub>min</sub>	HIS	EG55
R111.3367.02	3,95	6,7	10,7	0,2	8	1,8	11	111080R	▲
R111.3367.04	3,95	6,7	10,7	0,4	8	1,8	11	111080R	▲
L111.3367.02	3,95	6,7	10,7	0,2	8	1,8	11	111080L	Δ
L111.3367.04	3,95	6,7	10,7	0,4	8	1,8	11	111080L	Δ

P	●
M	○
K	○
N	-
S	-
H	-

# Plaquette de coupe

Inserto

# 111

$\varnothing \geq 11$  mm

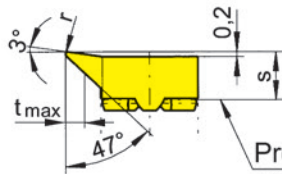
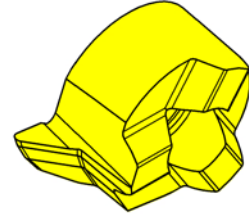
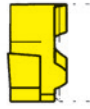
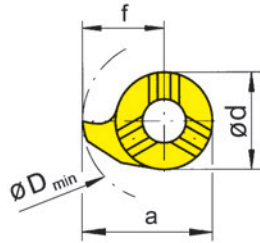
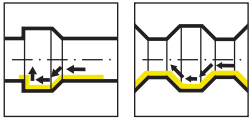

Profil frontal du porte outils  
Profilo frontale del portainsero

R = version à droite représentée  
R = versione destra come in figura

L = version à gauche  
L = versione sinistra a specchio

▲ en stock  
a stock

Nuance  
Leghe  
Δ 4 semaines  
4 settimane

Numéro de commande Codice prodotto	s	f	a	r	d	t <sub>max</sub>	D <sub>min</sub>	HIS	Nuance Leghe			
									EG55	TH35	TI25	TN35
<b>R111.4767.02</b>	3,95	6,7	10,7	0,2	8	2,3	11	111080R	▲	▲	▲	▲
<b>R111.4767.04</b>	3,95	6,7	10,7	0,4	8	2,3	11	111080R	▲	▲	▲	▲
<b>L111.4767.02</b>	3,95	6,7	10,7	0,2	8	2,3	11	111080L	▲	▲	▲	▲
<b>L111.4767.04</b>	3,95	6,7	10,7	0,4	8	2,3	11	111080L	▲	▲	Δ	▲
<b>P</b>	●	●	●	●	●	●	●		●	●	●	●
<b>M</b>	○	●	●	●	●	●	●		○	●	●	●
<b>K</b>	○	●	●	●	●	●	●		○	●	●	●
<b>N</b>	-	●	●	●	●	●	●		-	●	●	●
<b>S</b>	-	●	●	●	●	●	●		-	●	●	●
<b>H</b>	-	-	-	-	-	-	-		-	-	-	-



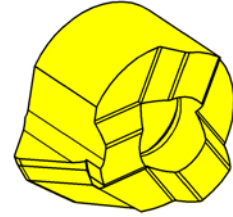
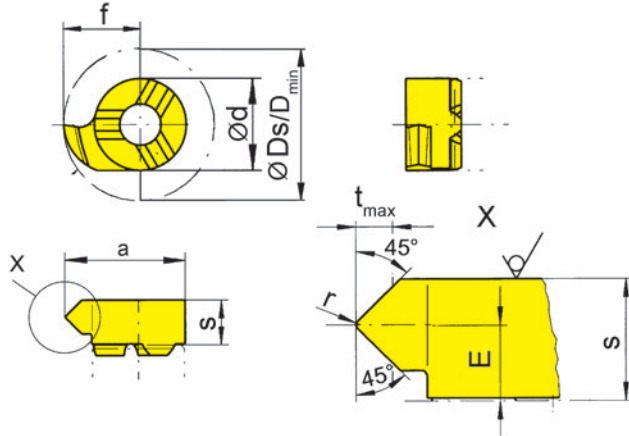
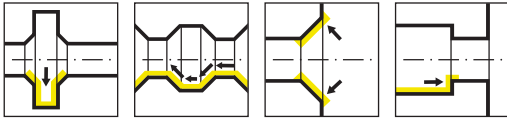

R = version à droite représentée  
R = versione destra come in figura

L = version à gauche  
L = versione sinistra a specchio

▲ en stock  
a stock

Nuance  
Leghe  
Δ 4 semaines  
4 settimane

Numéro de commande Codice prodotto	E	f	Ds	r	d	s	a	t <sub>max</sub>	D <sub>min</sub>	Z	HIS	Nuance Leghe		
												EG55	TN35	
R111.4545.02	2,4	6,7	13,4	0,2	8	4,15	10,7	1,5	11	1	111080R	▲	▲	
L111.4545.02	2,4	6,7	13,4	0,2	8	4,15	10,7	1,5	11	1	111080L	▲	▲	
												P	●	●
												M	○	●
												K	○	●
												N	-	●
												S	-	●
												H	-	-

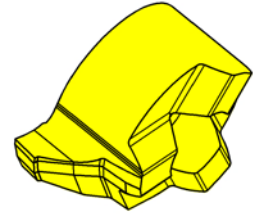
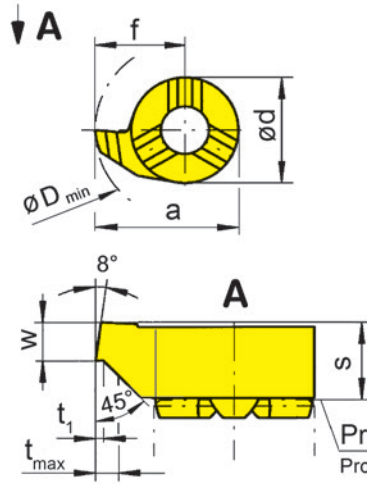
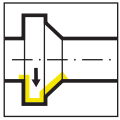

Profil frontal du porte outils  
Profilo frontale del portainsero

R = version à droite représentée  
R = versione destra come in figura

L = version à gauche  
L = versione sinistra a specchio

▲ en stock  
a stock

Nuance  
Leghe  
Δ 4 semaines  
4 settimane

Numéro de commande Codice prodotto	w	s	a	f	d	t <sub>max</sub>	t <sub>1max</sub>	D <sub>min</sub>	HIS	Nuance Leghe	
										EG55	TI25
R111.0810.45	1	3,95	10,7	6,7	8	1,5	0,2	11	111080R	▲	▲
L111.0810.45	1	3,95	10,7	6,7	8	1,5	0,2	11	111080L	▲	▲
										P	● ●
										M	○ ●
										K	○ ●
										N	- ●
										S	- ●
										H	- -



# Plaquette de coupe

## Inserto

# 111

$\varnothing \geq 11 \text{ mm}$

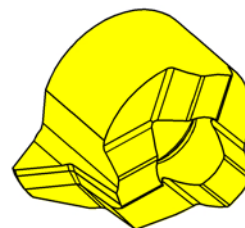
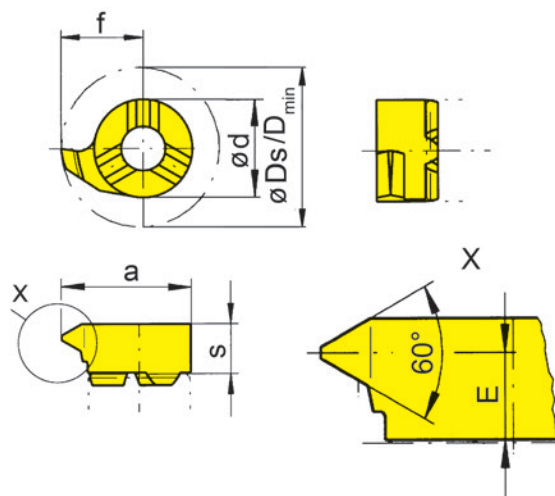

R = version à droite représentée  
R = versione destra come in figura

L = version à gauche  
L = versione sinistra a specchio

▲ en stock  
a stock

Nuance  
Leghe  
Δ 4 semaines  
4 settimane

Numéro de commande Codice prodotto	P	P <sub>max</sub>	E	s	f	a	d	Ds	D <sub>min</sub>	HIS	Nuance Leghe		
											EG55	TH35	TN35
R111.0205.01	0,5	0,75	3,5	4,15	6,7	10,7	8	13,4	11	111080R	▲	▲	▲
R111.0510.01	1	1,25	3,3	4,15	6,7	10,7	8	13,4	11	111080R	▲	▲	▲
R111.0815.01	1,5	1,75	3,3	4,15	6,7	10,7	8	13,4	11	111080R	▲	▲	▲
R111.1020.01	2	2	3	4,15	6,7	10,7	8	13,4	11	111080R	▲	▲	▲
R111.1325.01	2,5	2,5	2,8	4,15	6,7	10,7	8	13,4	11	111080R	▲	▲	▲
L111.0205.01	0,5	0,75	3,5	4,15	6,7	10,7	8	13,4	11	111080L	Δ	Δ	▲
L111.0510.01	1	1,25	3,3	4,15	6,7	10,7	8	13,4	11	111080L	▲	Δ	▲
L111.0815.01	1,5	1,75	3,3	4,15	6,7	10,7	8	13,4	11	111080L	▲	Δ	▲
L111.1020.01	2	2	3	4,15	6,7	10,7	8	13,4	11	111080L	Δ	Δ	▲
L111.1325.01	2,5	2,5	2,8	4,15	6,7	10,7	8	13,4	11	111080L	Δ	Δ	▲
<b>P</b>											●	●	●
<b>M</b>											○	●	●
<b>K</b>											○	●	●
<b>N</b>											-	●	●
<b>S</b>											-	●	●
<b>H</b>											-	-	-

H

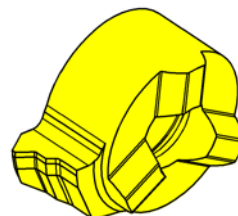
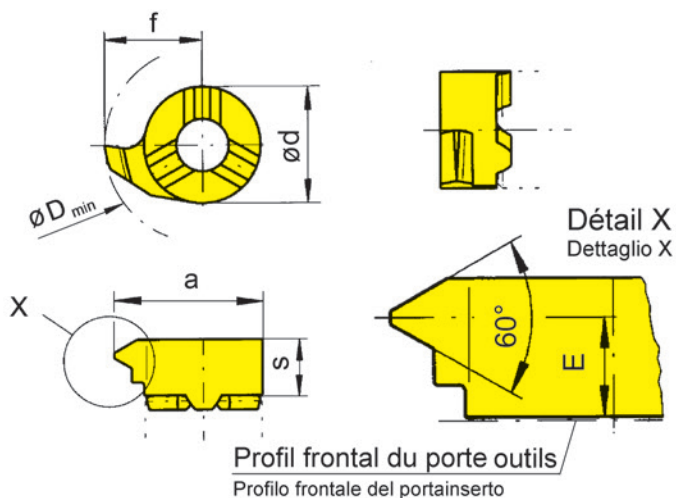

R = version à droite représentée  
R = versione destra come in figura

L = version à gauche  
L = versione sinistra a specchio

▲ en stock  
a stock

Nuance  
Leghe  
Δ 4 semaines  
4 settimane

Numéro de commande Codice prodotto	P	E	f	a	d	s	D <sub>min</sub>	HIS	Nuance Leghe		
									EG55	TI25	TN35
R111.0510.02	1	3,3	6,7	10,7	8	4,15	11	111080R	▲		▲
R111.0815.02	1,5	3,3	6,7	10,7	8	4,15	11	111080R	▲	Δ	▲
R111.1020.02	2	3	6,7	10,7	8	4,15	11	111080R	▲	Δ	▲
R111.1325.02	2,5	2,8	6,7	10,7	8	4,15	11	111080R	▲		▲
R111.1630.02	3	2,8	6,7	10,7	8	4,15	11	111080R	▲	Δ	▲
L111.0510.02	1	3,3	6,7	10,7	8	4,15	11	111080L	Δ		▲
L111.0815.02	1,5	3,3	6,7	10,7	8	4,15	11	111080L	▲	Δ	▲
L111.1020.02	2	3	6,7	10,7	8	4,15	11	111080L	▲		▲
L111.1325.02	2,5	2,8	6,7	10,7	8	4,15	11	111080L	Δ		Δ
L111.1630.02	3	2,8	6,7	10,7	8	4,15	11	111080L	Δ		Δ
P	●	●	●								
M	○	●	●								
K	○	●	●								
N	-	●	●								
S	-	●	●								
H	-	-	-								



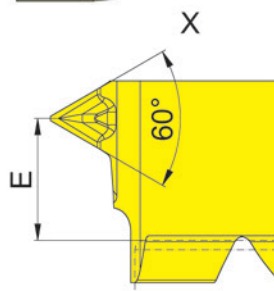
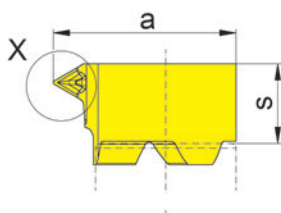
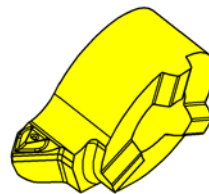
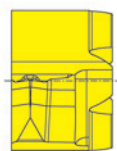
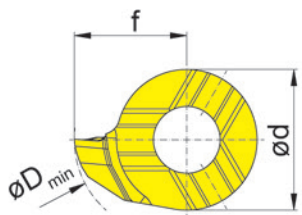

R = version à droite représentée  
R = versione destra come in figura

Nuance  
Leghe  
▲ en stock    Δ 4 semaines  
a stock        4 settimane

Numéro de commande Codice prodotto	P	P <sub>max</sub>	E	f	a	d	s	D <sub>min</sub>	HIS	EG55
RS111.0205.GM1	0,5	0,75	3,1	6,7	10,7	8	4,1	11	111080R	▲
RS111.0510.GM1	1	1,25	3,1	6,7	10,7	8	4,1	11	111080R	▲
RS111.0815.GM1	1,5	1,75	3,1	6,7	10,7	8	4,1	11	111080R	▲
RS111.1020.GM1	2	2	3,1	6,7	10,7	8	4,1	11	111080R	▲
LS111.0205.GM1	0,5	0,75	3,1	6,7	10,7	8	4,1	11	111080L	▲
LS111.0510.GM1	1	1,25	3,1	6,7	10,7	8	4,1	11	111080L	▲
LS111.0815.GM1	1,5	1,75	3,1	6,7	10,7	8	4,1	11	111080L	▲
LS111.1020.GM1	2	2	3,1	6,7	10,7	8	4,1	11	111080L	▲
	P	●								
	M	o								
	K	o								
	N	-								
	S	-								
	H	-								

H

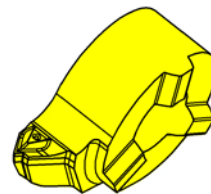
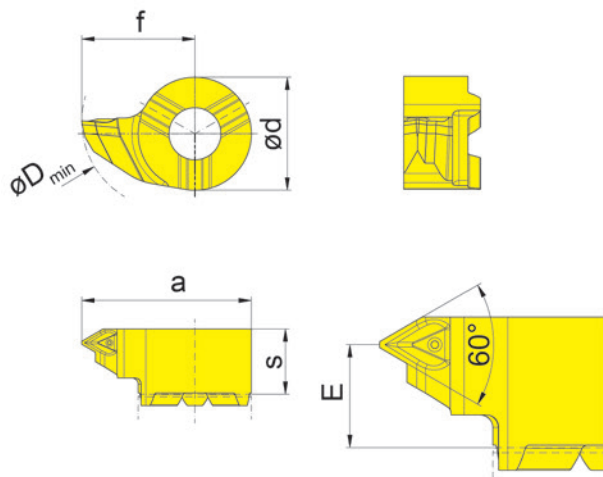

R = version à droite représentée  
R = versione destra come in figura

▲ en stock  
a stock

Nuance  
Leghe  
Δ 4 semaines  
4 settimane

Numéro de commande Codice prodotto	P	E	f	a	d	s	D <sub>min</sub>	HIS	EG55
RS111.0510.GM2	1	3,1	6,7	10,7	8	4,1	11	111080R	▲
RS111.0815.GM2	1,5	3,1	6,7	10,7	8	4,1	11	111080R	▲
RS111.1020.GM2	2	3,1	6,7	10,7	8	4,1	11	111080R	▲
LS111.0510.GM2	1	3,1	6,7	10,7	8	4,1	11	111080L	▲
LS111.0815.GM2	1,5	3,1	6,7	10,7	8	4,1	11	111080L	▲
LS111.1020.GM2	2	3,1	6,7	10,7	8	4,1	11	111080L	▲
	P	●							
	M	o							
	K	o							
	N	-							
	S	-							
	H	-							



# Plaquette de coupe

## Inserto

# 111

$\emptyset \geq 11 \text{ mm}$

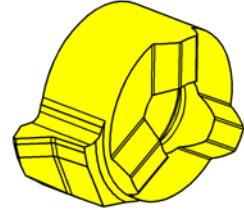
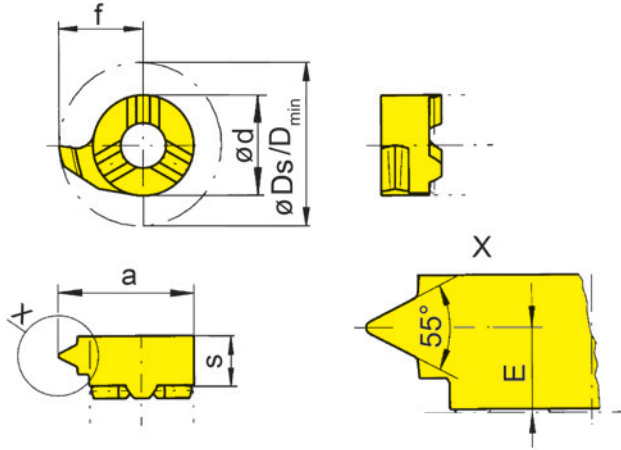

R = version à droite représentée  
R = versione destra come in figura

L = version à gauche  
L = versione sinistra a specchio

▲ en stock  
a stock

Nuance  
Leghe  
Δ 4 semaines  
4 settimane

Numéro de commande Codice prodotto	TPI	E	s	f	a	d	Ds	D <sub>min</sub>	HIS	Nuance Leghe		
										EG55	TN35	
R111.5514.02	14	2,5	4,15	6,7	10,7	8	13,4	11	111080R	▲	▲	
R111.5519.02	19	2,9	4,15	6,7	10,7	8	13,4	11	111080R	▲	▲	
L111.5514.02	14	2,5	4,15	6,7	10,7	8	13,4	11	111080L	Δ	▲	
L111.5519.02	19	2,9	4,15	6,7	10,7	8	13,4	11	111080L		▲	
										P	●	●
										M	○	●
										K	○	●
										N	-	●
										S	-	●
										H	-	-

H

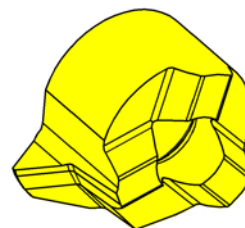
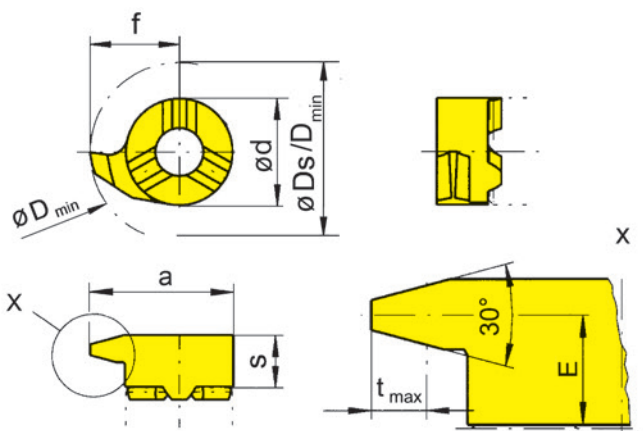

R = version à droite représentée  
R = versione destra come in figura

L = version à gauche  
L = versione sinistra a specchio

▲ en stock  
a stock

Nuance  
Leghe  
Δ 4 semaines  
4 settimane

Numéro de commande Codice prodotto	P	E	f	a	d	s	D <sub>min</sub>	D <sub>s</sub>	HIS	Nuance Leghe	
										EG55	TN35
R111.1015.01	1,5	3,5	6,7	10,7	8	4,15	11	13,4	111080R	▲	▲
R111.1220.01	2	3,3	6,7	10,7	8	4,15	11	13,4	111080R	▲	▲
R111.2240.01	4	2,5	6,7	10,7	8	4,15	11	13,4	111080R	▲	▲
L111.1015.01	1,5	3,5	6,7	10,7	8	4,15	11	13,4	111080L	Δ	Δ
L111.1220.01	2	3,3	6,7	10,7	8	4,15	11	13,4	111080L	▲	▲
L111.2240.01	4	2,5	6,7	10,7	8	4,15	11	13,4	111080L	▲	▲
										P	●
										M	○
										K	○
										N	-
										S	-
										H	-





H

**11P**



**Porte outils et plaquettes**

**Portainsero e inserti**

**I**

Porte outils  
Portainsero  
B11P

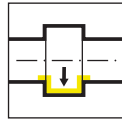

Page/Pag.  
282-283

Plaque de coupe  
Inserto  
11P/S11P

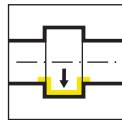

Page/Pag.  
284, 287



Page/Pag.  
285, 288

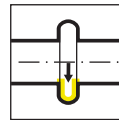

Page/Pag.  
286

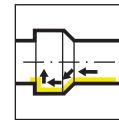

Page/Pag.  
289, 293



Page/Pag.  
290

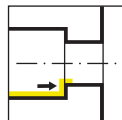

Page/Pag.  
291

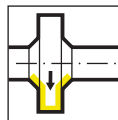

Page/Pag.  
292

Ø Alésage Foro Ø	Type de produit / Linea di prodotto											
	105	109	110	106	107	108	10P	111	11P	114	116	18P
≥ 0,2	•											
≥ 0,5	•											
≥ 0,7	•											
≥ 1,0	•											
≥ 1,5	•											
≥ 2,0	•											
≥ 3,0	•											
≥ 4,0	•											
≥ 5,0	•											
≥ 6,0	•	•	•	•								
≥ 6,8		•	•	•								
≥ 7,0		•			•							
≥ 7,8			•		•	•						
≥ 8,0			•		•	•						
≥ 9,0			•		•	•	•					
≥ 10,0			•				•	•	•			
≥ 10,5									•			
≥ 11,0								•	•			
≥ 11,5									•			
≥ 13,8										•		
≥ 14,0										•	•	
≥ 16,0											•	
≥ 16,5										{•}		
≥ 18,0												•
Profondeur de gorge Profondità della gola	2,5	2,5	4,0	0,8	2,0	1,0	3,0	2,3	3,5	4,0 (6,5)	4,3	8,0
Largeur de gorge Larghezza della gola	0,5- 2,0	1,0- 2,0	1,0- 3,0	0,7- 1,5	1,0- 2,0	0,7- 2,0	1,0- 3,0	0,7- 3,0	1,0- 3,0	0,7- 3,0	0,7- 4,0	2,0- 3,0
Usinage / Operazione												
Gorge Gole	•	•	•	•	•	•	•	•	•	•	•	•
Alésage Alesatura	•	•	•	•	•	•		•		•	•	
Filetage Filettatura	•	•			•	•		•		•	•	
Chanfreinage Smussatura	•	•			•	•		•		•	•	
Gorge frontale Gole assiali	•	•	•							•		
Alésage et Profil Alesatura e Profilatura	•											

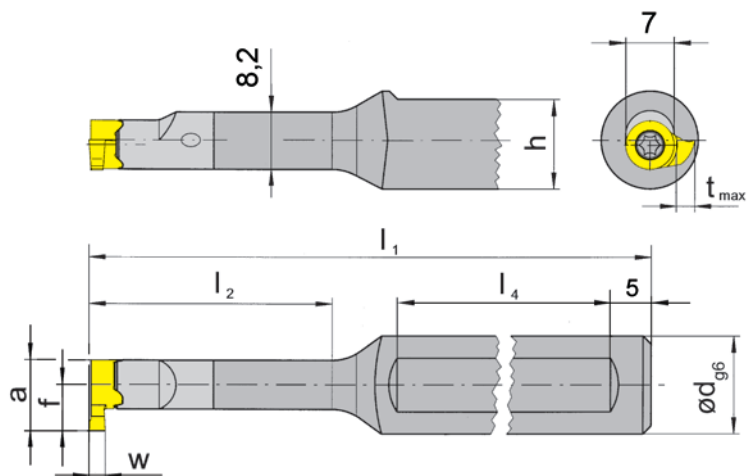
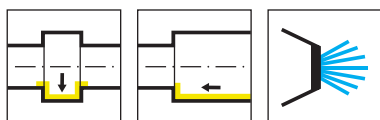

R = version à droite représentée  
R = versione destra come in figura

L = version à gauche  
L = versione sinistra a specchio

Numéro de commande Codice prodotto	d	l <sub>1</sub>	l <sub>2</sub>	h	l <sub>4</sub>	HWS
RB11P.0012.00	12	75	15	11	40	11P070R
RB11P.0012.01	12	95	26	11	50	11P070R
RB11P.0012.02	12	110	37	11	50	11P070R
RB11P.0012.03	12	120	50	11	50	11P070R
LB11P.0012.00	12	75	15	11	40	11P070L
LB11P.0012.01	12	95	26	11	50	11P070L
LB11P.0012.02	12	110	37	11	50	11P070L
LB11P.0012.03	12	120	50	11	50	11P070L

w, a, tmax et f voir plaquettes  
w, a, tmax, f vd. Inserti

### Pièces Détachées

Ricambi

Porte outils Portainsero	Vis de serrage Vite di serraggio	Tournevis TORX PLUS® Cacciavite TORX PLUS®
R/LB11P...	3.10T9P	T9PL

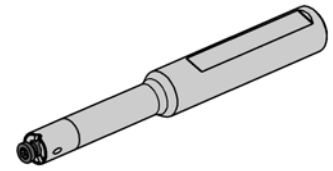
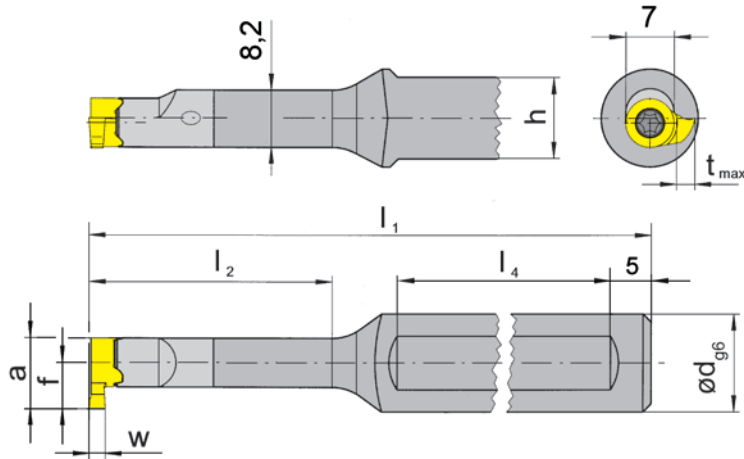
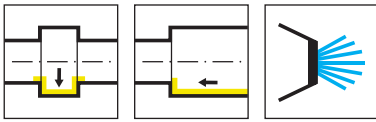

R = version à droite représentée  
R = versione destra come in figura

L = version à gauche  
L = versione sinistra a specchio

Numéro de commande Codice prodotto	d	l <sub>1</sub>	l <sub>2</sub>	h	l <sub>4</sub>	HWS
RB11P.0012.2.00	12	75	15	11	40	11P070R
RB11P.0012.2.01	12	95	26	11	50	11P070R
RB11P.0012.2.02	12	110	37	11	50	11P070R
RB11P.0012.2.03	12	120	50	11	50	11P070R
LB11P.0012.2.00	12	75	15	11	40	11P070L
LB11P.0012.2.01	12	95	26	11	50	11P070L
LB11P.0012.2.02	12	110	37	11	50	11P070L
LB11P.0012.2.03	12	120	50	11	50	11P070L

w, a, t\_max et f voir plaquettes  
w, a, t\_max, f vd. Inserti

### Pièces Détachées

Ricambi

Porte outils Portainsero	Vis de serrage Vite di serraggio	Tournevis TORX PLUS® Cacciavite TORX PLUS®
R/LB11P...	3.10T9P	T9PL

# Plaquette de coupe

## Inserto

# 11P

$\varnothing \geq 10,5 \text{ mm}$

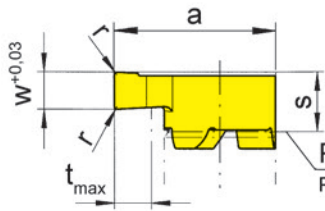
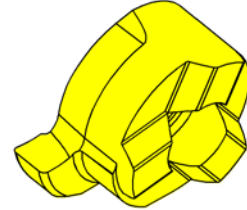
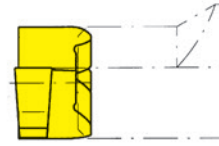
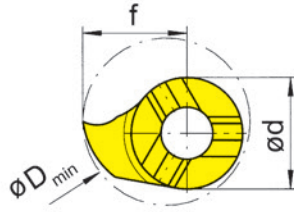
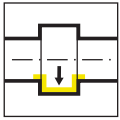

Profil frontal du porte outils  
Profilo frontale del portainsero

R = version à droite représentée  
R = versione destra come in figura

L = version à gauche  
L = versione sinistra a specchio

▲ en stock  
a stock

Nuance  
Leghe  
Δ 4 semaines  
4 settimane

Numéro de commande Codice prodotto	w	s	f	a	r	d	t <sub>max</sub>	D <sub>min</sub>	HIS	Nuance	
										EG55	TH35
R11P.0100.1.00	1	4,2	6,5	10	-	7	2,5	10,5	11P070R	▲	▲
R11P.0150.1.00	1,5	4,2	6,5	10	-	7	2,5	10,5	11P070R	▲	▲
R11P.0200.1.02	2	4,2	6,5	10	0,2	7	2,5	10,5	11P070R	▲	▲
R11P.0250.1.02	2,5	4,2	6,5	10	0,2	7	2,5	10,5	11P070R	▲	▲
R11P.0300.1.02	3	4,2	6,5	10	0,2	7	2,5	10,5	11P070R	Δ	▲
L11P.0100.1.00	1	4,2	6,5	10	-	7	2,5	10,5	11P070L	Δ	▲
L11P.0150.1.00	1,5	4,2	6,5	10	-	7	2,5	10,5	11P070L	Δ	Δ
L11P.0200.1.02	2	4,2	6,5	10	0,2	7	2,5	10,5	11P070L	▲	▲
L11P.0250.1.02	2,5	4,2	6,5	10	0,2	7	2,5	10,5	11P070L	Δ	▲
L11P.0300.1.02	3	4,2	6,5	10	0,2	7	2,5	10,5	11P070L	Δ	▲
										P	● ●
										M	○ ●
										K	○ ●
										N	- ●
										S	- ●
										H	- -

# Plaquette de coupe Inserto

## S11P $\varnothing \geq 10,5$ mm

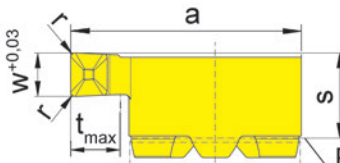
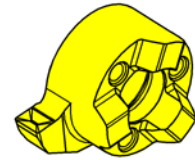
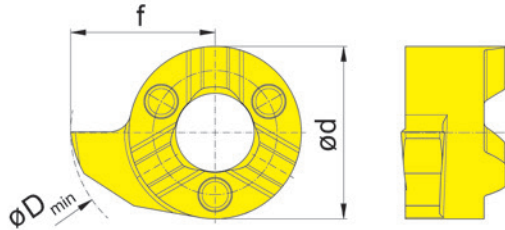
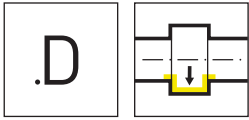

Profil frontal du porte outils  
Profilo frontale del portainsero

R = version à droite représentée  
R = versione destra come in figura

L = version à gauche  
L = versione sinistra a specchio

▲ en stock  
a stock

Nuance  
Leghe  
Δ 4 semaines  
4 settimane

Numéro de commande Codice prodotto	w	s	f	a	r	d	t <sub>max</sub>	D <sub>min</sub>	HIS	Nuance Leghe	
										EG55	TH35
RS11P.0150.1.D1	1,5	4,2	6,5	10	0,1	7	2,5	10,5	11P070R	▲	▲
RS11P.0200.1.D2	2	4,2	6,5	10	0,2	7	2,5	10,5	11P070R	▲	▲
RS11P.0250.1.D2	2,5	4,2	6,5	10	0,2	7	2,5	10,5	11P070R	▲	▲
LS11P.0150.1.D1	1,5	4,2	6,5	10	0,1	7	2,5	10,5	11P070L	Δ	▲
LS11P.0200.1.D2	2	4,2	6,5	10	0,2	7	2,5	10,5	11P070L	Δ	▲
LS11P.0250.1.D2	2,5	4,2	6,5	10	0,2	7	2,5	10,5	11P070L	Δ	Δ
										P	●
										M	○
										K	○
										N	-
										S	-
										H	-

# Plaquette de coupe

## Inserto

# 11P

$\varnothing \geq 11,5 \text{ mm}$

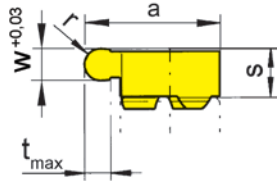
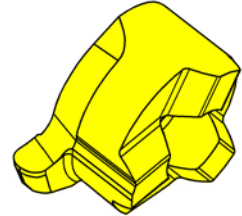
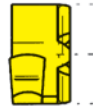
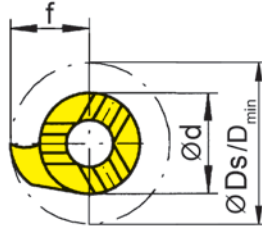
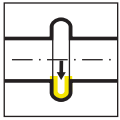

R = version à droite représentée  
R = versione destra come in figura

L = version à gauche  
L = versione sinistra a specchio

▲ en stock  
a stock

Nuance  
Leghe  
Δ 4 semaines  
4 settimane

Numéro de commande Codice prodotto	w	s	f	a	r	d	t <sub>max</sub>	D <sub>min</sub>	HIS	EG55
R11P.0005.2.10	1	4,2	7,5	11	0,5	7	3,5	11,5	11P070R	▲
R11P.0007.2.15	1,5	4,2	7,5	11	0,75	7	3,5	11,5	11P070R	▲
R11P.0009.2.18	1,8	4,2	7,5	11	0,9	7	3,5	11,5	11P070R	▲
R11P.0010.2.20	2	4,2	7,5	11	1	7	3,5	11,5	11P070R	▲
L11P.0005.2.10	1	4,2	7,5	11	0,5	7	3,5	11,5	11P070L	▲
L11P.0007.2.15	1,5	4,2	7,5	11	0,75	7	3,5	11,5	11P070L	▲
L11P.0009.2.18	1,8	4,2	7,5	11	0,9	7	3,5	11,5	11P070L	▲
L11P.0010.2.20	2	4,2	7,5	11	1	7	3,5	11,5	11P070L	▲

P	●
M	o
K	o
N	-
S	-
H	-

# Plaquette de coupe Inserto

# 11P

$\varnothing \geq 11,5 \text{ mm}$

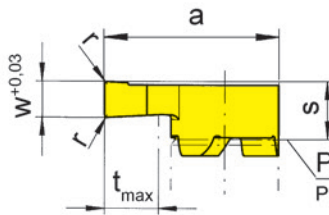
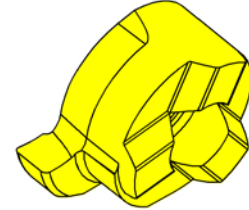
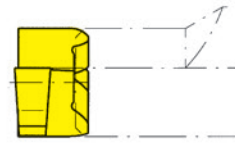
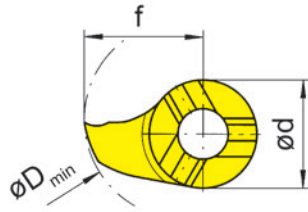
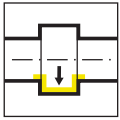

Profil frontal du porte outils  
Profilo frontale del portainsero

R = version à droite représentée  
R = versione destra come in figura

L = version à gauche  
L = versione sinistra a specchio

▲ en stock  
a stock

Nuance  
Leghe  
Δ 4 semaines  
4 settimane

Numéro de commande Codice prodotto	w	s	f	a	r	d	t <sub>max</sub>	D <sub>min</sub>	HIS	Nuance	
										EG55	TH35
R11P.0100.2.00	1	4,2	7,5	11	-	7	3,5	11,5	11P070R	▲	▲
R11P.0150.2.00	1,5	4,2	7,5	11	-	7	3,5	11,5	11P070R	▲	▲
R11P.0200.2.02	2	4,2	7,5	11	0,2	7	3,5	11,5	11P070R	▲	▲
L11P.0100.2.00	1	4,2	7,5	11	-	7	3,5	11,5	11P070L	Δ	▲
L11P.0150.2.00	1,5	4,2	7,5	11	-	7	3,5	11,5	11P070L	Δ	▲
L11P.0200.2.02	2	4,2	7,5	11	0,2	7	3,5	11,5	11P070L	▲	▲
										P	●
										M	○
										K	○
										N	-
										S	-
										H	-

# Plaquette de coupe Inserto

## S11P $\varnothing \geq 11,5$ mm

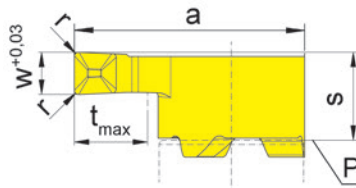
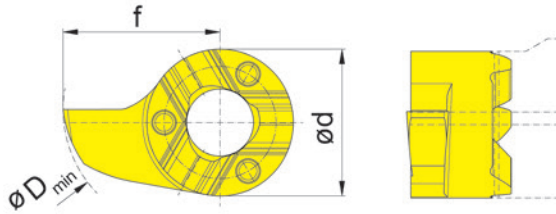
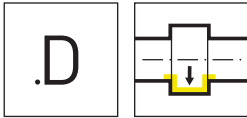

Profil frontal du porte outils  
Profilo frontale del portainsero

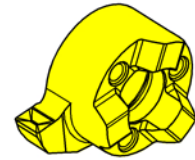

R = version à droite représentée  
R = versione destra come in figura

L = version à gauche  
L = versione sinistra a specchio

▲ en stock  
a stock

Nuance  
Leghe  
Δ 4 semaines  
4 settimane

Numéro de commande Codice prodotto	w	s	f	a	r	d	t <sub>max</sub>	D <sub>min</sub>	HIS	Nuance Leghe	
										EG55	TH35
RS11P.0150.2.D1	1,5	4,2	7,5	11	0,1	7	3,5	11,5	11P070R	▲	▲
RS11P.0200.2.D2	2	4,2	7,5	11	0,2	7	3,5	11,5	11P070R	▲	▲
RS11P.0250.2.D2	2,5	4,2	7,5	11	0,2	7	3,5	11,5	11P070R	▲	▲
LS11P.0150.2.D1	1,5	4,2	7,5	11	0,1	7	3,5	11,5	11P070L	Δ	▲
LS11P.0200.2.D2	2	4,2	7,5	11	0,2	7	3,5	11,5	11P070L	▲	▲
LS11P.0250.2.D2	2,5	4,2	7,5	11	0,2	7	3,5	11,5	11P070L	Δ	▲
										P	●
										M	○
										K	○
										N	-
										S	-
										H	-

# Plaquette de coupe

## Inserto

# 11P

$\varnothing \geq 10,5 \text{ mm}$

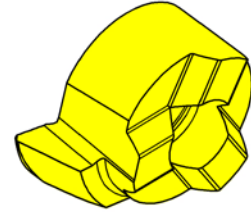
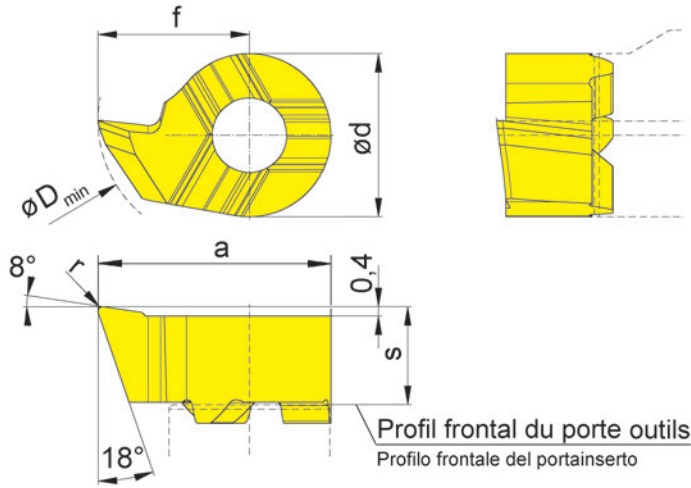
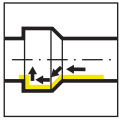

R = version à droite représentée  
R = versione destra come in figura

L = version à gauche  
L = versione sinistra a specchio

▲ en stock  
a stock

Nuance  
Leghe  
Δ 4 semaines  
4 settimane

Numéro de commande Codice prodotto	s	f	a	r	d	D <sub>min</sub>	HIS	Nuance Leghe	
								EG55	TH35
<b>R11P.1865.1.02</b>	4,2	6,5	10	0,2	7	10,5	11P070R	▲	▲
<b>L11P.1865.1.02</b>	4,2	6,5	10	0,2	7	10,5	11P070L	Δ	▲
								P ● ●	
								M ○ ●	
								K ○ ●	
								N - ●	
								S - ●	
								H - -	

# Plaquette de coupe

Inserto

# S11P

$\varnothing \geq 9,8 \text{ mm}$

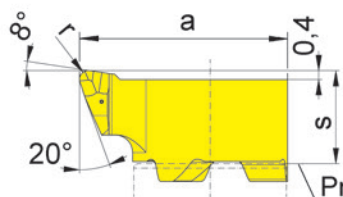
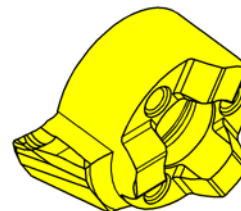
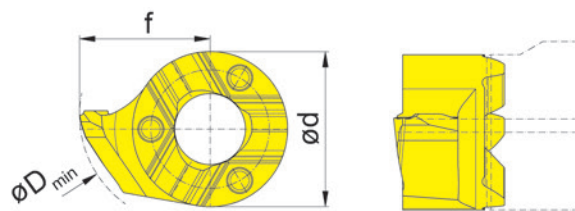

Profil frontal du porte outils  
Profilo frontale del portainsero

R = version à droite représentée  
R = versione destra come in figura

L = version à gauche  
L = versione sinistra a specchio

▲ en stock  
a stock

Nuance  
Leghe  
Δ 4 semaines  
4 settimane

Numéro de commande Codice prodotto	s	f	a	r	d	D <sub>min</sub>	HIS	Nuance Leghe	
								EG55	TH35
RS11P.1859.R2	4,2	5,9	9,4	0,2	7	9,8	11P070R	▲	▲
RS11P.1859.R4	4,2	5,9	9,4	0,4	7	9,8	11P070R	▲	▲
LS11P.1859.R2	4,2	5,9	9,4	0,2	7	9,8	11P070L		▲
LS11P.1859.R4	4,2	5,9	9,4	0,4	7	9,8	11P070L	▲	▲
								P	● ●
								M	○ ●
								K	○ ●
								N	- ●
								S	- ●
								H	- -

# Plaquette de coupe

## Inserto

# 11P

$\varnothing \geq 11,5 \text{ mm}$

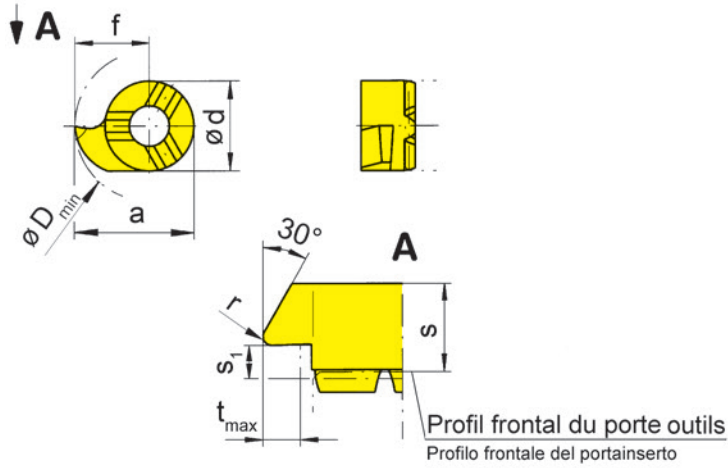
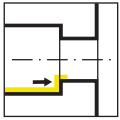

Nuance  
Leghe

R = version à droite représentée  
R = versione destra come in figura

L = version à gauche  
L = versione sinistra a specchio

▲ en stock  
a stock

Δ 4 semaines  
4 settimane

Numéro de commande Codice prodotto	s	f	a	r	s <sub>1</sub>	d	t <sub>max</sub>	D <sub>min</sub>	HIS	EG55
<b>R11P.3075.2.02</b>	4,35	7,5	11	0,2	1,6	7	3,5	11,5	11P070R	▲
<b>L11P.3075.2.02</b>	4,35	7,5	11	0,2	1,6	7	3,5	11,5	11P070L	▲
										P ●
										M ○
										K ○
										N -
										S -
										H -

# Plaquette de coupe

Inserto

# 11P

$\varnothing \geq 10,5 \text{ mm}$

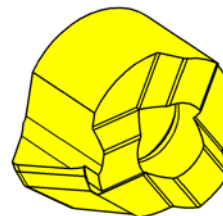
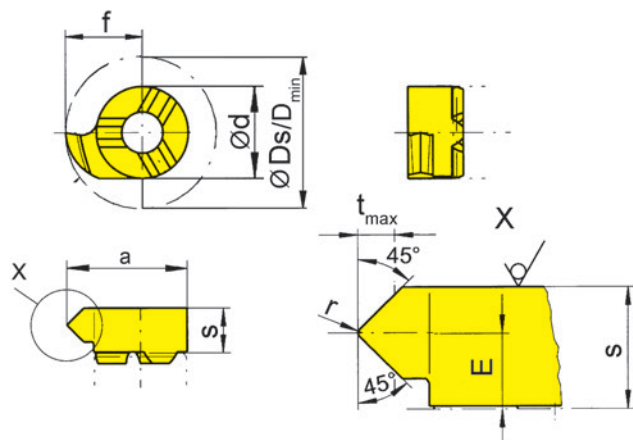

Nuance  
Leghe

R = version à droite représentée  
R = versione destra come in figura

L = version à gauche  
L = versione sinistra a specchio

▲ en stock  
a stock

Δ 4 semaines  
4 settimane

Numéro de commande Codice prodotto	E	f	r	d	s	a	$D_{\min}$	$\alpha$	$t_{\max}$	HIS	EG55
<b>R11P.4545.1.02</b>	2,2	6,5	0,2	7	4,35	10	10,5	45°	1,7	11P070R	▲
<b>L11P.4545.1.02</b>	2,2	6,5	0,2	7	4,35	10	10,5	45°	1,7	11P070L	▲
											P ●
											M ○
											K ○
											N -
											S -
											H -

# Plaquette de coupe

## Inserto

# 11P

$\varnothing \geq 11,5 \text{ mm}$

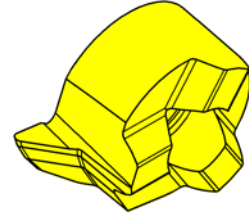
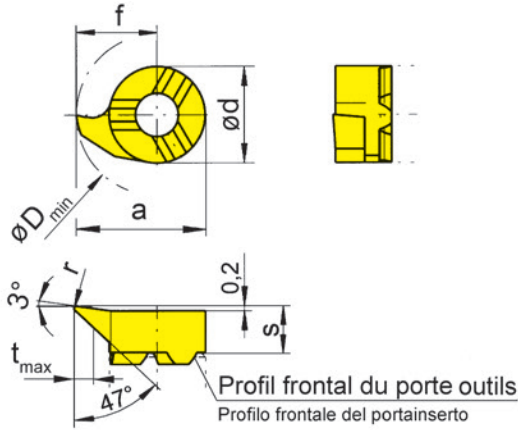
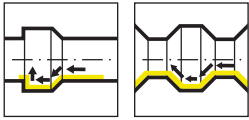

R = version à droite représentée  
R = versione destra come in figura

L = version à gauche  
L = versione sinistra a specchio

▲ en stock  
a stock

Nuance  
Leghe  
Δ 4 semaines  
4 settimane

Numéro de commande Codice prodotto	s	f	a	r	d	t <sub>max</sub>	D <sub>min</sub>	HIS	EG55
<b>R11P.4775.2.02</b>	4,2	7,5	11	0,2	7	3,5	11,5	11P070R	▲
<b>L11P.4775.2.02</b>	4,2	7,5	11	0,2	7	3,5	11,5	11P070L	▲
									P ●
									M ○
									K ○
									N -
									S -
									H -



**114**



**Porte outils et plaquettes**

**Portainsero e inserti**

**J**

Porte outils  
Portainsero  
B114/WFB.114/BA114/  
HC114

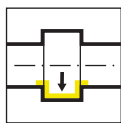

Page/Pag.  
298-300

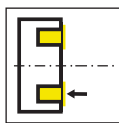

Page/Pag.  
301-302

Plaque de coupe  
Inserto  
114/S114



Page/Pag.  
303-304

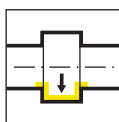

Page/Pag.  
305, 307



Page/Pag.  
306, 308

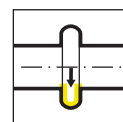

Page/Pag.  
309

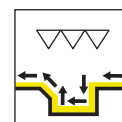

Page/Pag.  
310



Page/Pag.  
311

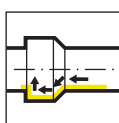

Page/Pag.  
312, 315-316



Page/Pag.  
313

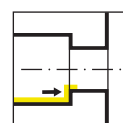

Page/Pag.  
314

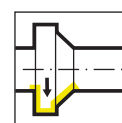

Page/Pag.  
317

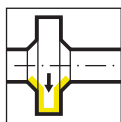

Page/Pag.  
318

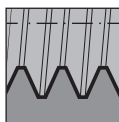

Page/Pag.  
319-323

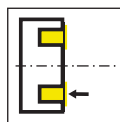

Page/Pag.  
324-329

Ø Alésage Foro Ø	Type de produit / Linea di prodotto											
	105	109	110	106	107	108	10P	111	11P	114	116	18P
≥ 0,2	•											
≥ 0,5	•											
≥ 0,7	•											
≥ 1,0	•											
≥ 1,5	•											
≥ 2,0	•											
≥ 3,0	•											
≥ 4,0	•											
≥ 5,0	•											
≥ 6,0	•	•	•	•								
≥ 6,8		•	•	•								
≥ 7,0		•			•							
≥ 7,8			•		•	•						
≥ 8,0			•		•	•						
≥ 9,0			•		•	•	•					
≥ 10,0			•				•	•	•			
≥ 10,5									•			
≥ 11,0								•	•			
≥ 11,5									•			
≥ 13,8										•		
≥ 14,0										•	•	
≥ 16,0											•	
≥ 16,5										(•)		
≥ 18,0												•
Profondeur de gorge Profondità della gola	2,5	2,5	4,0	0,8	2,0	1,0	3,0	2,3	3,5	4,0 (6,5)	4,3	8,0
Largeur de gorge Larghezza della gola	0,5- 2,0	1,0- 2,0	1,0- 3,0	0,7- 1,5	1,0- 2,0	0,7- 2,0	1,0- 3,0	0,7- 3,0	1,0- 3,0	0,7- 3,0	0,7- 4,0	2,0- 3,0
Usinage / Operazione												
Gorge Gole	•	•	•	•	•	•	•	•	•	•	•	•
Alésage Alesatura	•	•	•	•	•	•		•		•	•	
Filetage Filettatura	•	•			•	•		•		•	•	
Chanfreinage Smussatura	•	•			•	•		•		•	•	
Gorge frontale Gole assiali	•	•	•							•		
Alésage et Profil Alesatura e Profilatura	•											

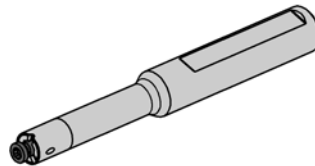
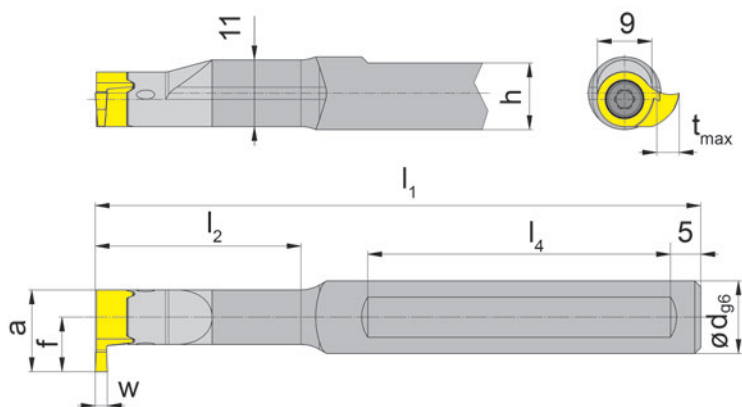
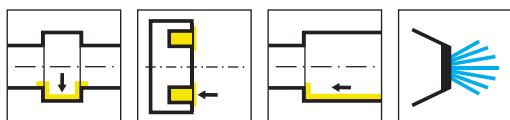

Illustration de coupe à droite représentée

Figura = taglio destro

Numéro de commande Codice prodotto	d	l <sub>1</sub>	l <sub>2</sub>	h	l <sub>4</sub>	HWS
B114.0012.00	12	75	19,5	11	40	114090R • 114090L
B114.0012.01	12	100	34	11	50	114090R • 114090L
B114.0012.02	12	110	45	11	50	114090R • 114090L
B114.0012.03	12	130	64	11	50	114090R • 114090L
B114.0016.00	16	80	19,5	15	40	114090R • 114090L
B114.0016.01	16	100	34	15	50	114090R • 114090L
B114.0016.02	16	110	45	15	50	114090R • 114090L
B114.0016.03	16	130	64	15	50	114090R • 114090L

w, a, tmax et f voir plaquettes

w, a, tmax, f vd. Inserti

## Pièces Détachées

Ricambi

Porte outils Portainsero	Vis de serrage Vite di serraggio	Tournevis TORX PLUS® Cacciavite TORX PLUS®
B114...	4.12T15EP	T15PQ

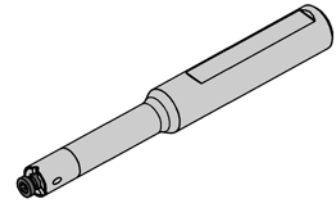
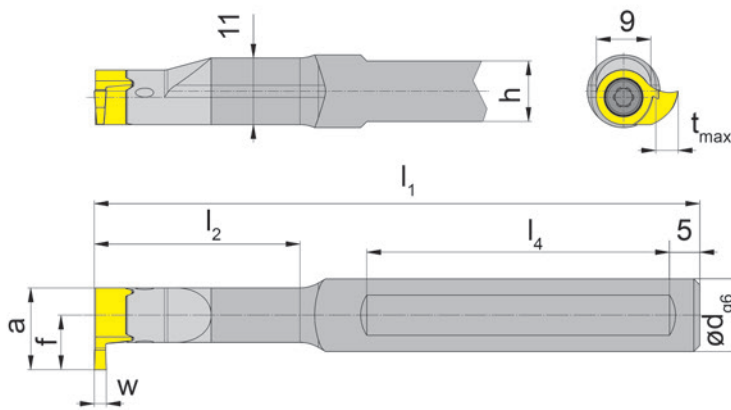
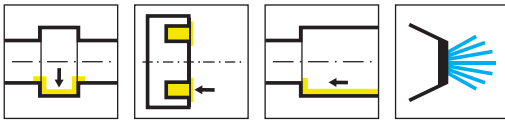

Illustration de coupe à droite représentée  
Figura = taglio destro

Numéro de commande Codice prodotto	d	l <sub>1</sub>	l <sub>2</sub>	h	l <sub>4</sub>	HWS
B114.0012.2.00	12	75	19,5	11	40	114090R • 114090L
B114.0012.2.01	12	100	34	11	50	114090R • 114090L
B114.0012.2.02	12	110	45	11	50	114090R • 114090L
B114.0012.2.03	12	130	64	11	50	114090R • 114090L
B114.0016.2.00	16	80	19,5	14	40	114090R • 114090L
B114.0016.2.01	16	100	34	14	50	114090R • 114090L
B114.0016.2.02	16	110	45	14	50	114090R • 114090L
B114.0016.2.03	16	130	64	14	50	114090R • 114090L

w, a, tmax et f voir plaquettes  
w, a, tmax, f vd. Inserti

### Pièces Détachées

Ricambi

Porte outils Portainsero	Vis de serrage Vite di serraggio	Tournevis TORX PLUS® Cacciavite TORX PLUS®
B114...	4.12T15EP	T15PQ

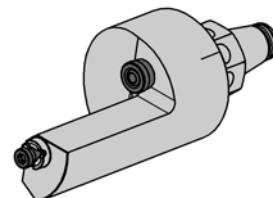
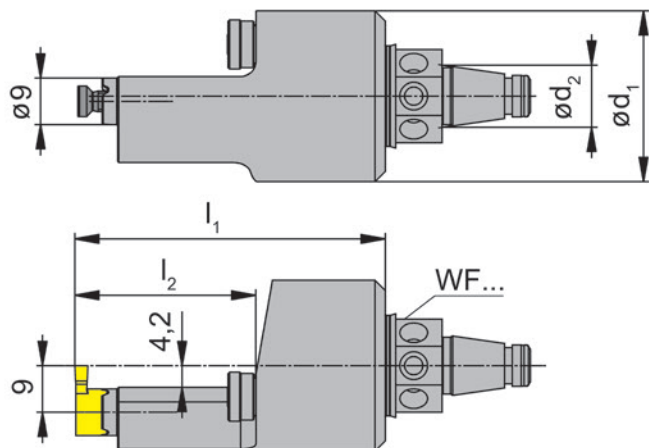
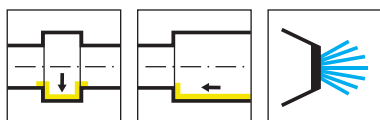

Numéro de commande Codice prodotto	$d_1$	$l_1$	$d_2$	$l_2$	HWS	HMS
<b>WFB.2HO.114</b>	33	60	12	35	114090R • 114090L	WFB
<b>WFB.3HO.114</b>	50	80	20	32	114090R • 114090L	WFB

**Pièces Détachées**

Ricambi

Porte outils Portainsero	Vis de serrage Vite di serraggio	Buse de pulvérisation d'arrosage Ugello nebulizzazione refrigerante	Tournevis TORX PLUS® Cacciavite TORX PLUS®
WF...	<b>4.12T15EP</b>	<b>020.0806.3116</b>	<b>T15PQ</b>

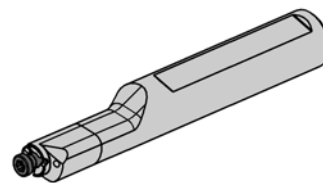
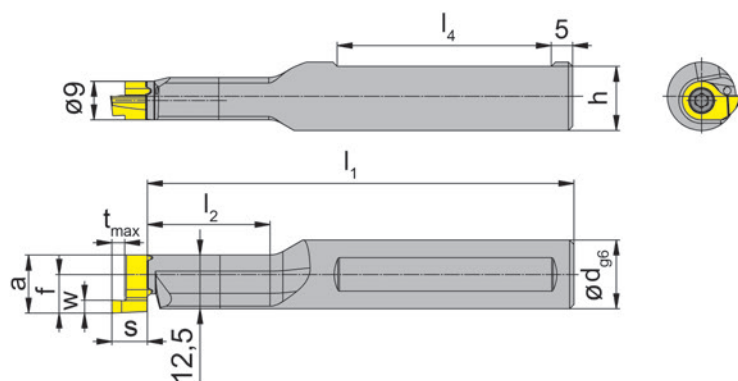
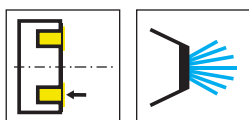

Illustration de coupe à droite représentée

Figura = taglio destro

Numéro de commande Codice prodotto	d	$l_1$	$l_2$	h	$l_4$	HWS
RBA114.0016.01	16	99,7	28,7	15	50	114090R • 114090L
RBA114.0016.02	16	109,7	39,7	15	50	114090R • 114090L
LBA114.0016.01	16	99,7	28,7	15	50	114090R • 114090L
LBA114.0016.02	16	109,7	39,7	15	50	114090R • 114090L

w, a, s, tmax et f voir plaquettes

w, a, s, tmax, f vd. Inserti

## Pièces Détachées

Ricambi

Porte outils Portainsero	Vis de serrage Vite di serraggio	Tournevis TORX PLUS® Cacciavite TORX PLUS®
R/LBA114...	4.12T15EP	T15PQ

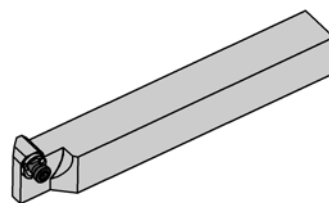
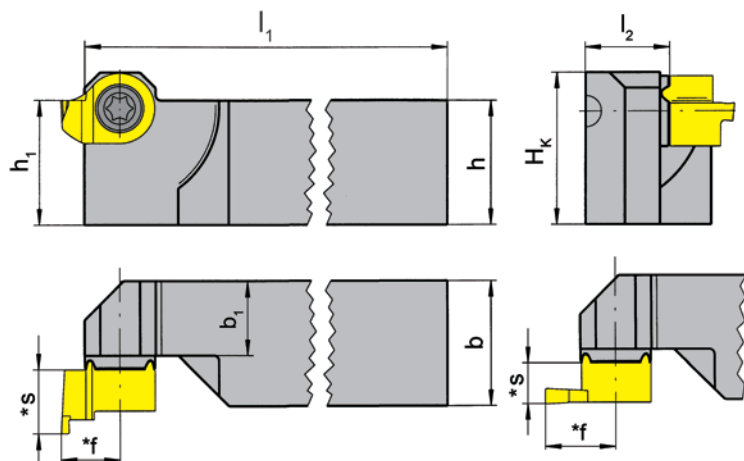
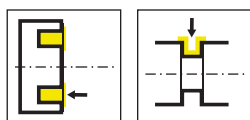

R = version à droite représentée  
R = versione destra come in figura

L = version à gauche  
L = versione sinistra a specchio

Numéro de commande Codice prodotto	h	b	l <sub>1</sub>	l <sub>2</sub>	h <sub>1</sub>	b <sub>1</sub>	H <sub>k</sub>	HWS
RHC114.1212.01	12	12	122	11,2	12	9,5	15,6	114090R • 114090L
RHC114.1616.01	16	16	122	11,2	16	9,5	19,6	114090R • 114090L
RHC114.2020.01	20	20	122	15,2	20	13,5	23,6	114090R • 114090L
RHC114.2525.01	25	25	147	20,2	25	18,5	28,6	114090R • 114090L
LHC114.1212.01	12	12	122	11,2	12	9,5	15,6	114090R • 114090L
LHC114.1616.01	16	16	122	11,2	16	9,5	19,6	114090R • 114090L
LHC114.2020.01	20	20	122	15,2	20	13,5	23,6	114090R • 114090L
LHC114.2525.01	25	25	147	20,2	25	18,5	28,6	114090R • 114090L

\* voir plaquettes  
\* vd. inserti

### Pièces Détachées

Ricambi

Porte outils Portainsero	Vis de serrage Vite di serraggio	Tournevis TORX PLUS® Cacciavite TORX PLUS®
R/LHC114...	4.12T15EP	T15PQ

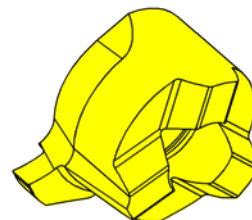
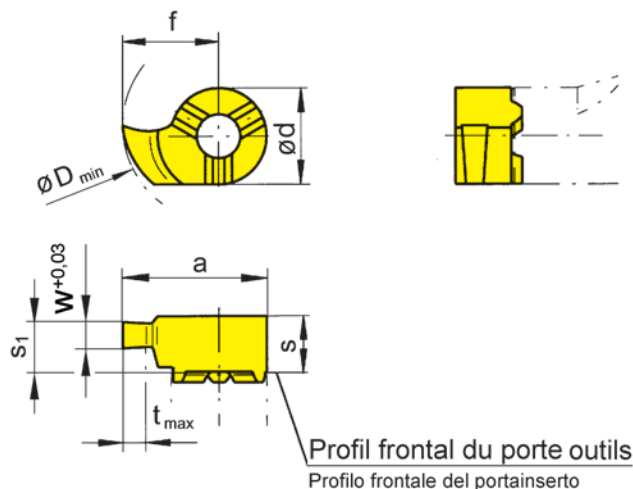
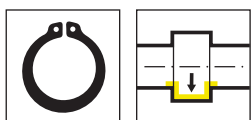

R = version à droite représentée  
R = versione destra come in figura

L = version à gauche  
L = versione sinistra a specchio

▲ en stock  
a stock

Nuance  
Leghe  
Δ 4 semaines  
4 settimane

Numéro de commande Codice prodotto	w	Nw	s	f	a	s <sub>1</sub>	d	t <sub>max</sub>	D <sub>min</sub>	HIS	Nuance Leghe	
											EG55	TN35
R114.0070.00	0,74	0,7	5,5	9	13,5	5,3	9	1,2	14	114090R	▲	▲
R114.0080.00	0,84	0,8	5,5	9	13,5	5,3	9	1,3	14	114090R	▲	▲
R114.0090.00	0,94	0,9	5,5	9	13,5	5,3	9	1,5	14	114090R	▲	▲
L114.0070.00	0,74	0,7	5,5	9	13,5	5,3	9	1,2	14	114090L		▲
L114.0080.00	0,84	0,8	5,5	9	13,5	5,3	9	1,3	14	114090L	Δ	▲
L114.0090.00	0,94	0,9	5,5	9	13,5	5,3	9	1,5	14	114090L	▲	▲

Profondeur de coupe limitée  
Profondità di taglio limitata

Largeurs pour gorges circlips DIN 471/472  
Larghezza per esecuzione anelli Seeger DIN 471/472

	EG55	TN35
P	●	●
M	○	●
K	○	●
N	-	●
S	-	●
H	-	-



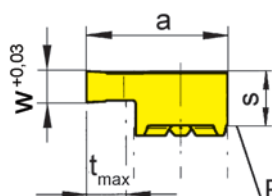
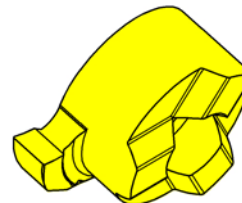
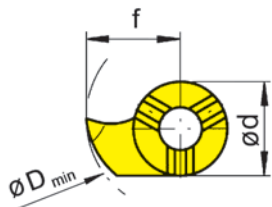
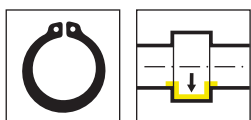

Profil frontal du porte outils  
Profilo frontale del portainsero

R = version à droite représentée  
R = versione destra come in figura

L = version à gauche  
L = versione sinistra a specchio

▲ en stock  
a stock

Nuance  
Leghe  
Δ 4 semaines  
4 settimane

Numéro de commande Codice prodotto	w	Nw	s	f	a	d	t <sub>max</sub>	D <sub>min</sub>	HIS	Nuance Leghe			
										EG55	TH35	TN35	
R114.0110.00	1,19	1,1	5,3	9	13,5	9	4	14	114090R	▲	▲	▲	
R114.0130.00	1,39	1,3	5,3	9	13,5	9	4	14	114090R	▲	▲	▲	
R114.0160.00	1,69	1,6	5,3	9	13,5	9	4	14	114090R	▲	▲	▲	
L114.0110.00	1,19	1,1	5,3	9	13,5	9	4	14	114090L	▲	▲	▲	
L114.0130.00	1,39	1,3	5,3	9	13,5	9	4	14	114090L	▲	▲	▲	
L114.0160.00	1,69	1,6	5,3	9	13,5	9	4	14	114090L	▲	▲	▲	
Largeurs pour gorges circlips DIN 471/472 Larghezza per esecuzione anelli Seeger DIN 471/472										P	●	●	●
										M	○	●	●
										K	○	●	●
										N	-	●	●
										S	-	●	●
										H	-	-	-

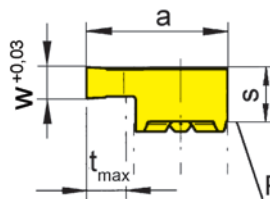
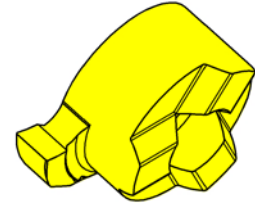
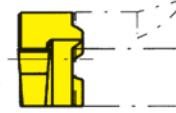
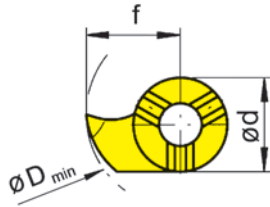
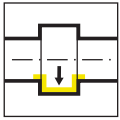

Profil frontal du porte outils  
Profilo frontale del portainsero

R = version à droite représentée  
R = versione destra come in figura

L = version à gauche  
L = versione sinistra a specchio

▲ en stock  
a stock

Nuance  
Leghe  
Δ 4 semaines  
4 settimane

Numéro de commande Codice prodotto	w	s	f	a	d	t <sub>max</sub>	D <sub>min</sub>	HIS	Nuance Leghe		
									EG55	TH35	TN35
R114.0150.00	1,5	5,3	9	13,5	9	4	14	114090R	▲	▲	▲
R114.0200.00	2	5,3	9	13,5	9	4	14	114090R	▲	▲	▲
R114.0250.00	2,5	5,3	9	13,5	9	4	14	114090R	▲	▲	▲
R114.0300.00	3	5,3	9	13,5	9	4	14	114090R	▲	▲	▲
L114.0150.00	1,5	5,3	9	13,5	9	4	14	114090L	▲	▲	▲
L114.0200.00	2	5,3	9	13,5	9	4	14	114090L	▲	▲	▲
L114.0250.00	2,5	5,3	9	13,5	9	4	14	114090L	▲	▲	▲
L114.0300.00	3	5,3	9	13,5	9	4	14	114090L	▲	▲	▲
P	●	●	●								
M	○	●	●								
K	○	●	●								
N	-	●	●								
S	-	●	●								
H	-	-	-								



# Plaquette de coupe Inserto

# S114

$\emptyset \geq 14$  mm

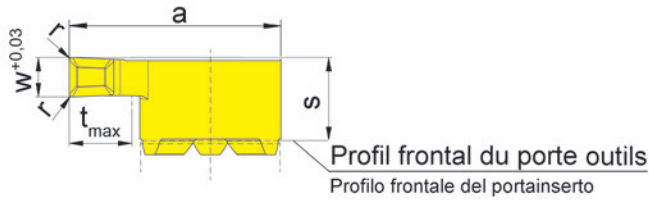
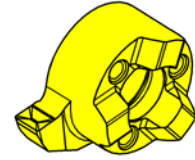
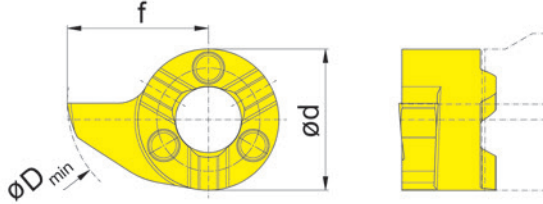
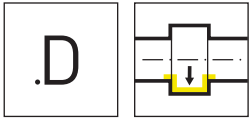

R = version à droite représentée  
R = versione destra come in figura

L = version à gauche  
L = versione sinistra a specchio

▲ en stock  
a stock

△ 4 semaines  
4 settimane

Nuance  
Leghe

Numéro de commande Codice prodotto	w	s	f	a	r	d	t <sub>max</sub>	D <sub>min</sub>	HIS	Nuance Leghe				
										EG55	TF45	TH35	TN35	
RS114.0200.D2	2	5,3	9	13,5	0,2	9	4	14	114090R	▲	▲	▲	▲	
RS114.0250.D2	2,5	5,3	9	13,5	0,2	9	4	14	114090R	▲	▲	▲	▲	
RS114.0300.D2	3	5,3	9	13,5	0,2	9	4	14	114090R	▲	▲	▲	▲	
LS114.0200.D2	2	5,3	9	13,5	0,2	9	4	14	114090L	▲	△	▲	▲	
LS114.0250.D2	2,5	5,3	9	13,5	0,2	9	4	14	114090L	▲	△	▲	▲	
LS114.0300.D2	3	5,3	9	13,5	0,2	9	4	14	114090L	▲	▲	▲	▲	
										P	●	●	●	●
										M	○	●	●	●
										K	○	●	●	●
										N	-	●	●	●
										S	-	●	●	●
										H	-	-	-	-

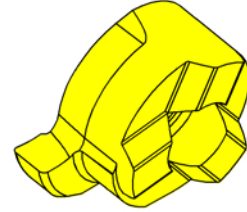
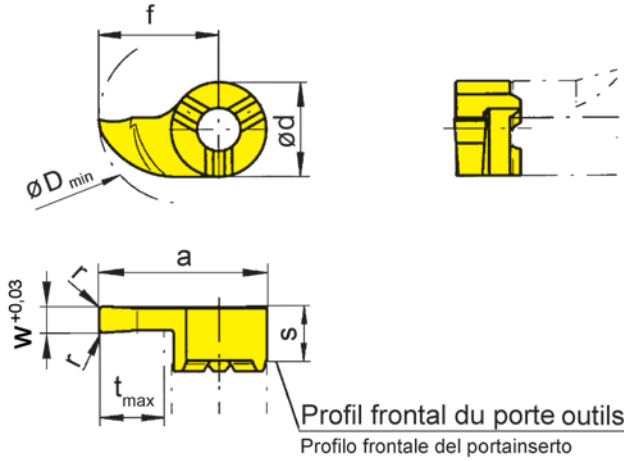
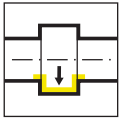

R = version à droite représentée  
R = versione destra come in figura

L = version à gauche  
L = versione sinistra a specchio

▲ en stock  
▲ a stock

Nuance  
Leghe  
Δ 4 semaines  
4 settimane

Numéro de commande Codice prodotto	w	s	f	a	r	d	t <sub>max</sub>	D <sub>min</sub>	HIS	Nuance Leghe				
										EG55	TH35	TI25	TN35	
R114.0150.1.02	1,5	5,3	11,3	15,8	0,2	9	6,5	16,5	114090R	▲	▲		▲	
R114.0200.1.02	2	5,3	11,3	15,8	0,2	9	6,5	16,5	114090R	▲	▲	▲	▲	
R114.0250.1.02	2,5	5,3	11,3	15,8	0,2	9	6,5	16,5	114090R	▲	▲		▲	
R114.0300.1.02	3	5,3	11,3	15,8	0,2	9	6,5	16,5	114090R	▲	▲		▲	
R114.0400.1.02	4	5,3	11,3	15,8	0,2	9	6,5	16,5	114090R	Δ				
L114.0150.1.02	1,5	5,3	11,3	15,8	0,2	9	6,5	16,5	114090L	▲	▲		▲	
L114.0200.1.02	2	5,3	11,3	15,8	0,2	9	6,5	16,5	114090L	▲	▲	Δ	▲	
L114.0250.1.02	2,5	5,3	11,3	15,8	0,2	9	6,5	16,5	114090L	▲	▲		▲	
L114.0300.1.02	3	5,3	11,3	15,8	0,2	9	6,5	16,5	114090L	▲	▲		▲	
L114.0400.1.02	4	5,3	11,3	15,8	0,2	9	6,5	16,5	114090L	Δ				
										P	●	●	●	●
										M	○	●	●	●
										K	○	●	●	●
										N	-	●	●	●
										S	-	●	●	●
										H	-	-	-	-

# Plaquette de coupe Inserto

## S114 $\varnothing \geq 16,5$ mm

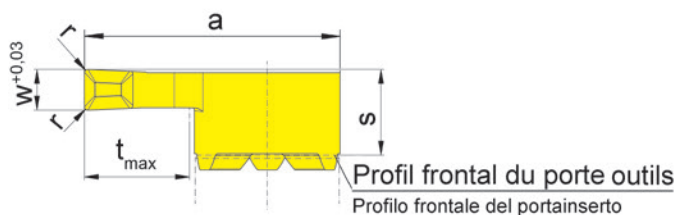
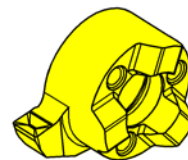
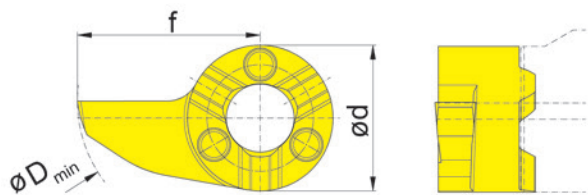
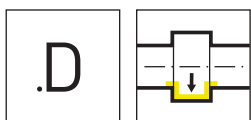

R = version à droite représentée  
R = versione destra come in figura

L = version à gauche  
L = versione sinistra a specchio

▲ en stock  
a stock

Nuance  
Leghe  
Δ 4 semaines  
4 settimane

Numéro de commande Codice prodotto	w	s	f	a	r	d	t <sub>max</sub>	D <sub>min</sub>	HIS	Nuance Leghe	
										EG55	TH35
RS114.0200.1.D2	2	5,3	11,3	15,8	0,2	9	6,5	16,5	114090R	▲	▲
RS114.0250.1.D2	2,5	5,3	11,3	15,8	0,2	9	6,5	16,5	114090R	▲	▲
RS114.0300.1.D2	3	5,3	11,3	15,8	0,2	9	6,5	16,5	114090R	▲	▲
LS114.0200.1.D2	2	5,3	11,3	15,8	0,2	9	6,5	16,5	114090L	▲	▲
LS114.0250.1.D2	2,5	5,3	11,3	15,8	0,2	9	6,5	16,5	114090L	Δ	▲
LS114.0300.1.D2	3	5,3	11,3	15,8	0,2	9	6,5	16,5	114090L	▲	▲
										P	●
										M	○
										K	○
										N	-
										S	-
										H	-

J

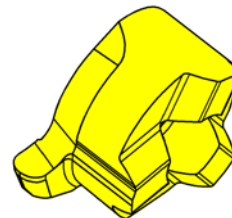
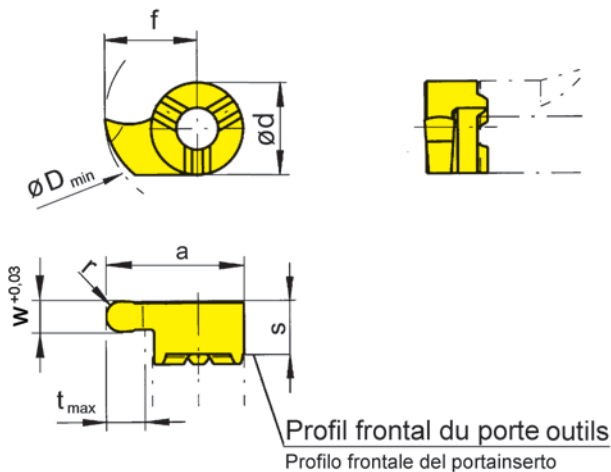
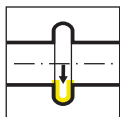

R = version à droite représentée  
R = versione destra come in figura

L = version à gauche  
L = versione sinistra a specchio

▲ en stock  
a stock

Nuance  
Leghe  
Δ 4 semaines  
4 settimane

Numéro de commande Codice prodotto	w	s	f	a	r	d	t <sub>max</sub>	D <sub>min</sub>	HIS	Nuance Leghe			
										EG55	TH35	TI25	TN35
R114.0004.08	0,8	5,3	9	13,5	0,4	9	4	14	114090R			▲	
R114.0006.12	1,2	5,3	9	13,5	0,6	9	4	14	114090R	▲	▲		▲
R114.0009.18	1,8	5,3	9	13,5	0,9	9	4	14	114090R	▲	▲		▲
R114.0010.20	2	5,3	9	13,5	1	9	4	14	114090R	▲	▲		▲
R114.0011.22	2,2	5,3	9	13,5	1,1	9	4	14	114090R	▲	▲		▲
R114.0015.30	3	5,3	9	13,5	1,5	9	4	14	114090R	▲	▲		▲
R114.0020.40	4	5,3	9	13,5	2	9	4	14	114090R	▲	▲		▲
L114.0004.08	0,8	5,3	9	13,5	0,4	9	4	14	114090L			▲	
L114.0006.12	1,2	5,3	9	13,5	0,6	9	4	14	114090L	▲	▲		▲
L114.0009.18	1,8	5,3	9	13,5	0,9	9	4	14	114090L	▲	▲		▲
L114.0010.20	2	5,3	9	13,5	1	9	4	14	114090L	▲	▲		▲
L114.0011.22	2,2	5,3	9	13,5	1,1	9	4	14	114090L	Δ	▲		▲
L114.0015.30	3	5,3	9	13,5	1,5	9	4	14	114090L	▲	▲		▲
L114.0020.40	4	5,3	9	13,5	2	9	4	14	114090L	Δ	Δ		
P	●	●	●	●	●	●	●	●					
M	○	●	●	●	●	●	●	●					
K	○	●	●	●	●	●	●	●					
N	-	●	●	●	●	●	●	●					
S	-	●	●	●	●	●	●	●					
H	-	-	-	-	-	-	-	-					



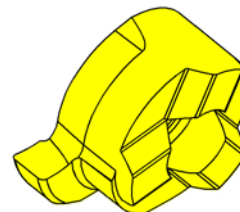
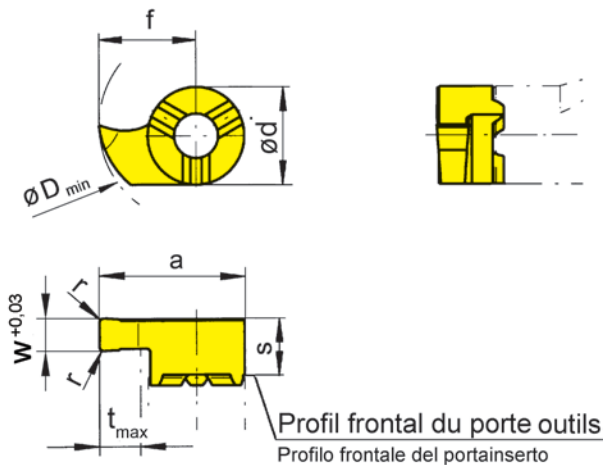
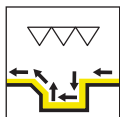

R = version à droite représentée  
R = versione destra come in figura

L = version à gauche  
L = versione sinistra a specchio

▲ en stock  
a stock

Nuance  
Leghe  
Δ 4 semaines  
4 settimane

Numéro de commande Codice prodotto	w	s	f	a	r	d	t <sub>max</sub>	D <sub>min</sub>	HIS	Nuance Leghe			
										EG55	TH35	TI25	TN35
R114.0200.02	2	5,3	9	13,5	0,2	9	4	14	114090R	▲	▲	▲	▲
L114.0200.02	2	5,3	9	13,5	0,2	9	4	14	114090L	▲	▲	▲	▲
P	●	●	●	●	●	●	●	●					
M	○	●	●	●	●	●	●	●					
K	○	●	●	●	●	●	●	●					
N	-	●	●	●	●	●	●	●					
S	-	●	●	●	●	●	●	●					
H	-	-	-	-	-	-	-	-					

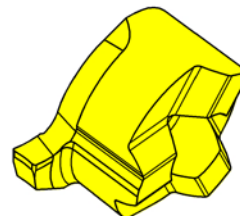
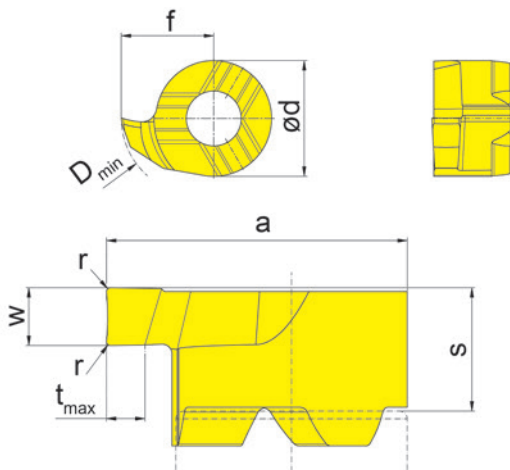

R = version à droite représentée  
R = versione destra come in figura

L = version à gauche  
L = versione sinistra a specchio

▲ en stock  
a stock

Nuance  
Leghe  
Δ 4 semaines  
4 settimane

Numéro de commande Codice prodotto	w	s	f	a	r	d	t <sub>max</sub>	D <sub>min</sub>	HIS	EG35
R114.FB10.01	1	5,3	9	13,5	0,1	9	4	14	114090R	▲
R114.FB15.01	1,5	5,3	9	13,5	0,1	9	4	14	114090R	▲
L114.FB10.01	1	5,3	9	13,5	0,1	9	4	14	114090L	▲
L114.FB15.01	1,5	5,3	9	13,5	0,1	9	4	14	114090L	▲

P ●

M ●

K ○

N -

S -

H -

Calcul de la plus petite largeur de gorge possible  $w_x$   
Calcolo della larghezza di gola  $w_x$  più basso possibile

Exemple R114.FB10.01  
Esempio

$w_x = 2 \times$  Largeur de gorge  $w - 2 \times$  Rayon d'angles plaquette  $r$

$w_x = 2 \times$  Larghezza della gola  $w - 2 \times$  Spigolo raggiato inserto  $r$

$w_x = 2 \times 1$  mm -  $2 \times 0,1$  mm

$w_x = 1,8$  mm

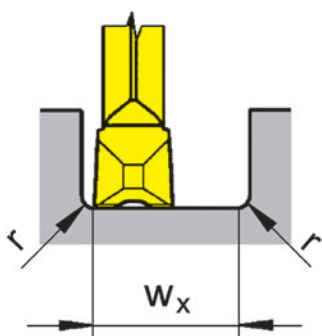

Déroulement du processus  
Percorso di lavoro



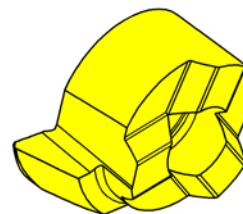
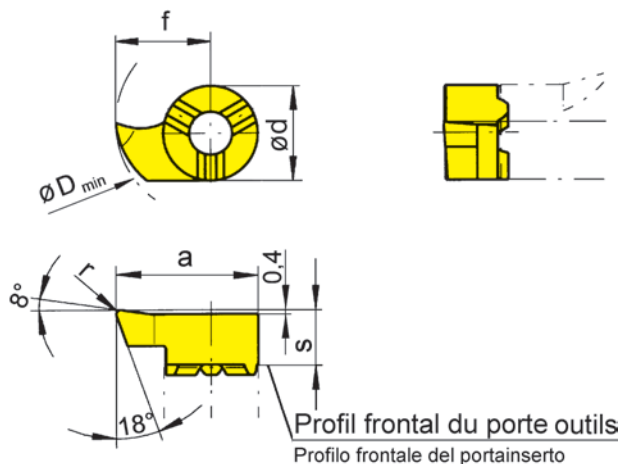
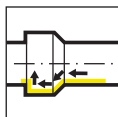

R = version à droite représentée  
R = versione destra come in figura

L = version à gauche  
L = versione sinistra a specchio

▲ en stock  
a stock

Nuance  
Leghe  
Δ 4 semaines  
4 settimane

Numéro de commande Codice prodotto	s	f	a	r	d	D <sub>min</sub>	HIS	Nuance Leghe		
								EG55	TH35	TN35
R114.1890.02	5,3	8,7	13,2	0,2	9	13,8	114090R	▲	▲	▲
L114.1890.02	5,3	8,7	13,2	0,2	9	13,8	114090L	▲	▲	▲
P	●	●	●	●	●	●				
M	○	●	●	●	●	●				
K	○	●	●	●	●	●				
N	-	●	●	●	●	●				
S	-	●	●	●	●	●				
H	-	-	-	-	-	-				

# Plaquette de coupe

Inserto

# S114

$\varnothing \geq 13,8 \text{ mm}$

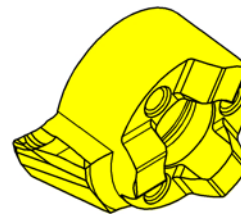
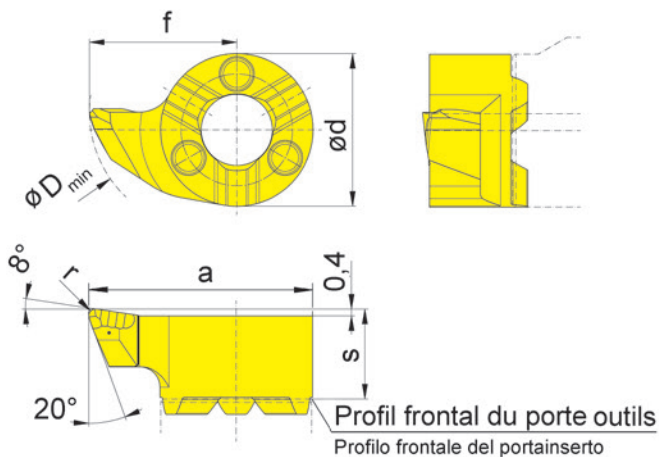

R = version à droite représentée  
R = versione destra come in figura

L = version à gauche  
L = versione sinistra a specchio

▲ en stock  
a stock

Nuance  
Leghe  
Δ 4 semaines  
4 settimane

Numéro de commande Codice prodotto	s	f	a	r	d	D <sub>min</sub>	HIS	Nuance Leghe	
								EG55	TH35
RS114.1890.R2	5,3	8,7	13,2	0,2	9	13,8	114090R	▲	▲
RS114.1890.R4	5,3	8,7	13,2	0,4	9	13,8	114090R	▲	▲
LS114.1890.R2	5,3	8,7	13,2	0,2	9	13,8	114090L	▲	▲
LS114.1890.R4	5,3	8,7	13,2	0,4	9	13,8	114090L	▲	▲
								P	● ●
								M	○ ●
								K	○ ●
								N	- ●
								S	- ●
								H	- -



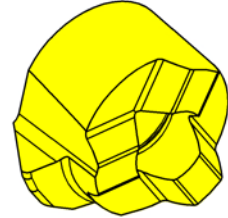
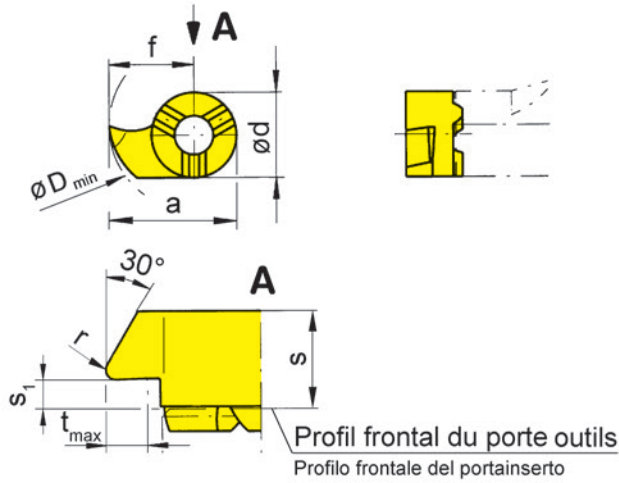
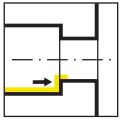

R = version à droite représentée  
R = versione destra come in figura

L = version à gauche  
L = versione sinistra a specchio

▲ en stock  
a stock

Nuance  
Leghe  
Δ 4 semaines  
4 settimane

Numéro de commande Codice prodotto	s	f	r	s <sub>1</sub>	d	t <sub>max</sub>	D <sub>min</sub>	HIS	Nuance Leghe		
									EG55	TH35	TN35
R114.3090.02	5,5	8,7	0,2	2,4	9	3,5	13,8	114090R	▲	▲	▲
L114.3090.02	5,5	8,7	0,2	2,4	9	3,5	13,8	114090L	▲	▲	▲
P	●	●	●								
M	○	●	●								
K	○	●	●								
N	-	●	●								
S	-	●	●								
H	-	-	-								

# Plaquette de coupe

Inserto

# 114

$\varnothing \geq 13,8 \text{ mm}$

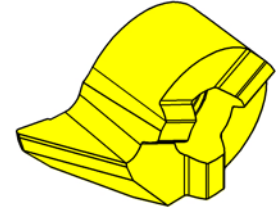
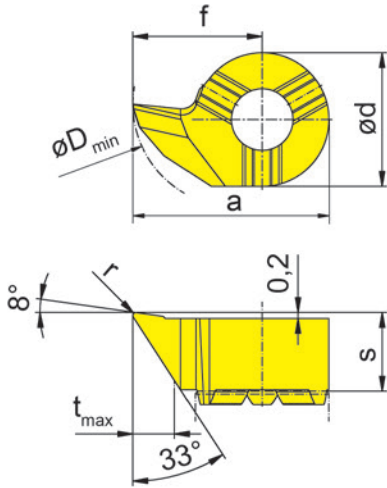
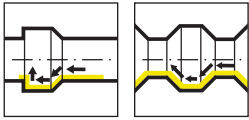

R = version à droite représentée  
R = versione destra come in figura

L = version à gauche  
L = versione sinistra a specchio

▲ en stock  
a stock

Nuance  
Leghe  
Δ 4 semaines  
4 settimane

Numéro de commande Codice prodotto	s	f	a	r	d	t <sub>max</sub>	D <sub>min</sub>	HIS	EG55
<b>R114.3387.02</b>	5,3	8,7	13,2	0,2	9	2,8	13,8	114090R	▲
<b>R114.3387.04</b>	5,3	8,7	13,2	0,4	9	2,8	13,8	114090R	▲
<b>L114.3387.02</b>	5,3	8,7	13,2	0,2	9	2,8	13,8	114090L	Δ
<b>L114.3387.04</b>	5,3	8,7	13,2	0,4	9	2,8	13,8	114090L	Δ

P	●
M	○
K	○
N	-
S	-
H	-



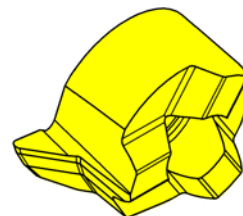
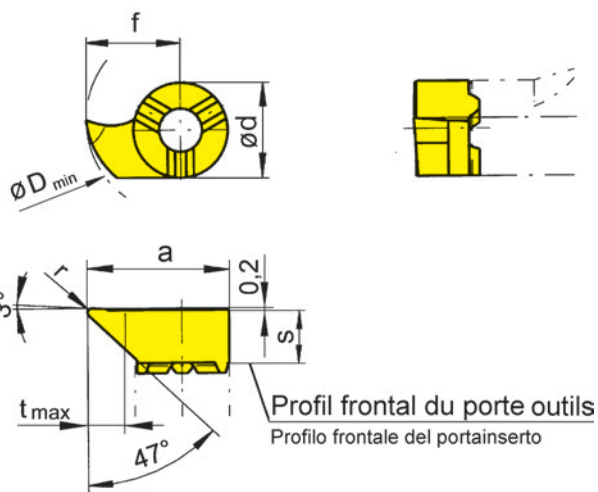
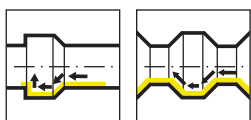

R = version à droite représentée  
R = versione destra come in figura

L = version à gauche  
L = versione sinistra a specchio

▲ en stock  
a stock

Nuance  
Leghe  
Δ 4 semaines  
4 settimane

Numéro de commande Codice prodotto	s	f	a	r	d	t <sub>max</sub>	D <sub>min</sub>	HIS	Nuance Leghe		
									EG55	TH35	TN35
R114.4787.02	5,3	8,7	13,2	0,2	9	3	13,8	114090R	▲	▲	▲
R114.4787.04	5,3	8,7	13,2	0,4	9	3	13,8	114090R	▲	▲	▲
R114.4710.02	5,3	11	15,5	0,2	9	5	16	114090R	▲	▲	▲
L114.4787.02	5,3	8,7	13,2	0,2	9	3	13,8	114090L	▲	▲	▲
L114.4787.04	5,3	8,7	13,2	0,4	9	3	13,8	114090L	▲	▲	▲
L114.4710.02	5,3	11	15,5	0,2	9	5	16	114090L	Δ	▲	▲
P	●	●	●	●	●	●	●	●	●	●	●
M	○	●	●	●	●	●	●	●	●	●	●
K	○	●	●	●	●	●	●	●	●	●	●
N	-	●	●	●	●	●	●	●	●	●	●
S	-	●	●	●	●	●	●	●	●	●	●
H	-	-	-	-	-	-	-	-	-	-	-

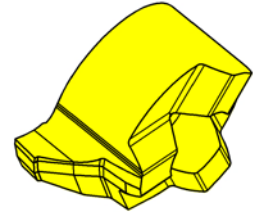
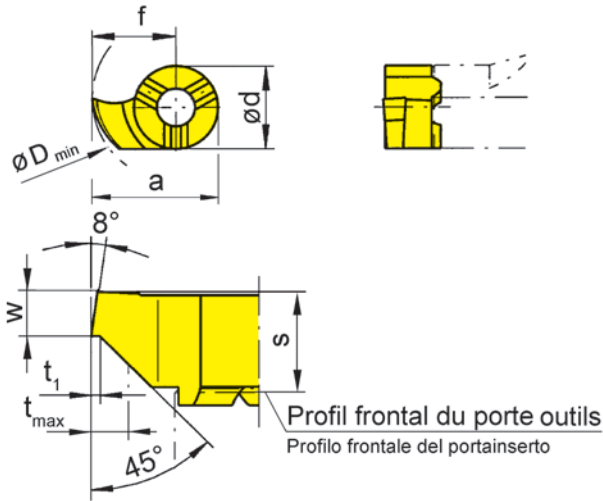
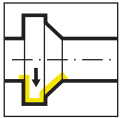

R = version à droite représentée  
R = versione destra come in figura

L = version à gauche  
L = versione sinistra a specchio

▲ en stock  
a stock

Nuance  
Leghe  
Δ 4 semaines  
4 settimane

Numéro de commande Codice prodotto	w	s	f	a	d	$t_{max}$	$t_1$	$D_{min}$	HIS	Nuance Leghe	
										EG55	TI25
R114.0815.45	1,5	5,3	9	13,5	9	1,5	0,2	14	114090R	▲	▲
L114.0815.45	1,5	5,3	9	13,5	9	1,5	0,2	14	114090L	▲	▲
										P	● ●
										M	○ ●
										K	○ ●
										N	- ●
										S	- ●
										H	- -

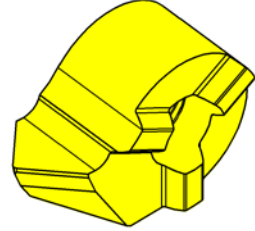
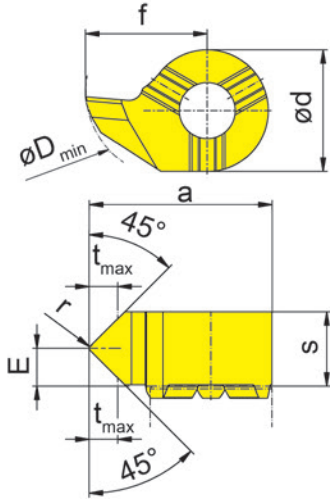
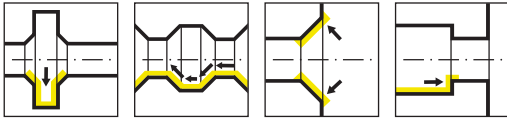

R = version à droite représentée  
R = versione destra come in figura

L = version à gauche  
L = versione sinistra a specchio

Nuance  
Leghe  
▲ en stock  
a stock  
Δ 4 semaines  
4 settimane

Numéro de commande Codice prodotto	E	s	f	a	r	d	t <sub>max</sub>	D <sub>min</sub>	HIS	EG55
R114.4545.02	2,8	5,5	9	13,5	0,2	9	2,1	14	114090R	▲
L114.4545.02	2,8	5,5	9	13,5	0,2	9	2,1	14	114090L	Δ
										P ●
										M ○
										K ○
										N -
										S -
										H -

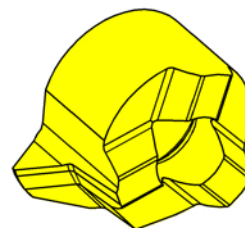
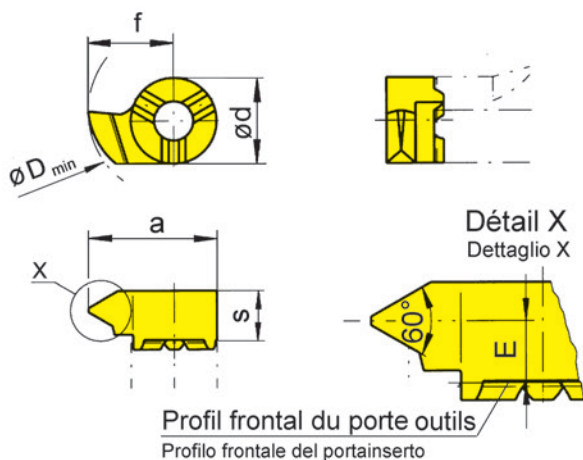

R = version à droite représentée  
R = versione destra come in figura

L = version à gauche  
L = versione sinistra a specchio

▲ en stock  
a stock

Nuance  
Leghe  
Δ 4 semaines  
4 settimane

Numéro de commande Codice prodotto	P	P <sub>max</sub>	E	f	a	d	s	D <sub>min</sub>	HIS	Nuance Leghe		
										EG55	TH35	TN35
R114.0205.01	0,5	0,75	4,8	9	9	9	5,5	14	114090R	▲	▲	▲
R114.0510.01	1	1,25	4,7	9	13,5	9	5,5	14	114090R	▲	▲	▲
R114.0815.01	1,5	1,75	4,5	9	13,5	9	5,5	14	114090R	▲	▲	▲
R114.1020.01	2	2	4,2	9	13,5	9	5,5	14	114090R	▲	▲	▲
R114.1325.01	2,5	2,5	4,2	9	13,5	9	5,5	14	114090R	▲	▲	▲
L114.0205.01	0,5	0,75	4,8	9	9	9	5,5	14	114090L	Δ	Δ	Δ
L114.0510.01	1	1,25	4,7	9	13,5	9	5,5	14	114090L	Δ	Δ	▲
L114.0815.01	1,5	1,75	4,5	9	13,5	9	5,5	14	114090L	▲	▲	▲
L114.1020.01	2	2	4,2	9	13,5	9	5,5	14	114090L	Δ	Δ	Δ
L114.1325.01	2,5	2,5	4,2	9	13,5	9	5,5	14	114090L	Δ	▲	Δ
	P	●	●	●								
	M	○	●	●								
	K	○	●	●								
	N	-	●	●								
	S	-	●	●								
	H	-	-	-								

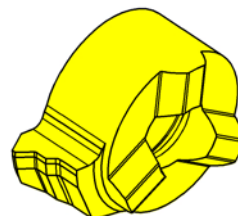
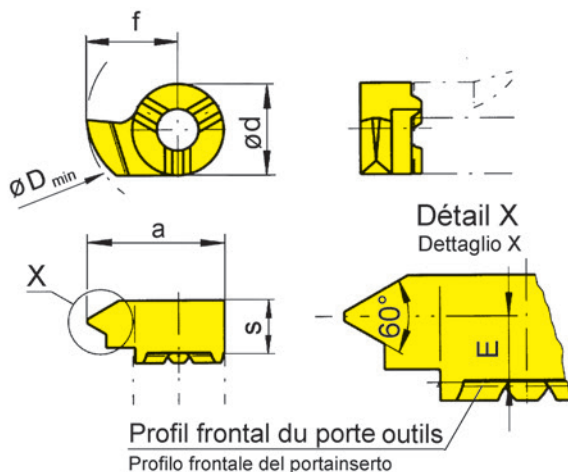

R = version à droite représentée  
R = versione destra come in figura

L = version à gauche  
L = versione sinistra a specchio

▲ en stock  
a stock

Nuance  
Leghe  
Δ 4 semaines  
4 settimane

Numéro de commande Codice prodotto	P	E	f	a	d	s	D <sub>min</sub>	HIS	Nuance Leghe		
									EG55	TN35	
R114.0510.02	1	4,7	9	13,5	9	5,5	14	114090R	▲	▲	
R114.0815.02	1,5	4,5	9	13,5	9	5,5	14	114090R	▲	▲	
R114.1020.02	2	4,2	9	13,5	9	5,5	14	114090R	▲	▲	
R114.1325.02	2,5	4,2	9	13,5	9	5,5	14	114090R	▲	▲	
L114.0510.02	1	4,7	9	13,5	9	5,5	14	114090L	Δ	▲	
L114.0815.02	1,5	4,5	9	13,5	9	5,5	14	114090L	Δ	▲	
L114.1020.02	2	4,2	9	13,5	9	5,5	14	114090L	Δ	▲	
L114.1325.02	2,5	4,2	9	13,5	9	5,5	14	114090L	Δ	▲	
									P	●	●
									M	○	●
									K	○	●
									N	-	●
									S	-	●
									H	-	-

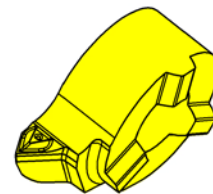
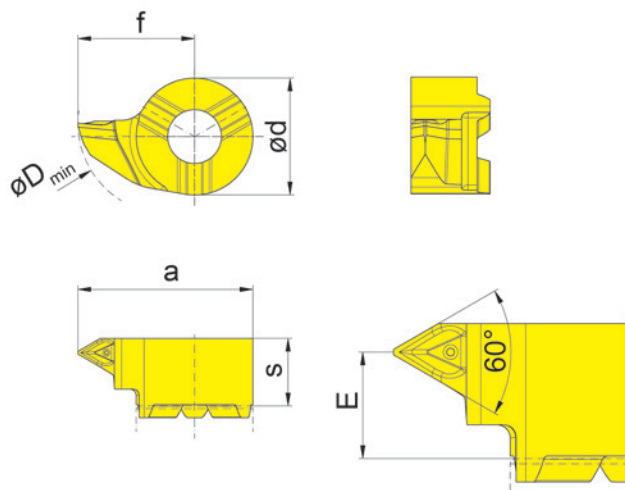

R = version à droite représentée  
R = versione destra come in figura

L = version à gauche  
L = versione sinistra a specchio

▲ en stock  
a stock

Nuance  
Leghe  
▲ 4 semaines  
4 settimane

Numéro de commande Codice prodotto	P	P <sub>max</sub>	E	f	a	d	s	D <sub>min</sub>	HIS	EG55
RS114.0205.GM1	0,5	0,75	4,1	9	13,5	9	5,2	14	114090R	▲
RS114.0510.GM1	1	1,25	4,1	9	13,5	9	5,2	14	114090R	▲
RS114.0815.GM1	1,5	1,75	4,1	9	13,5	9	5,2	14	114090R	▲
RS114.1020.GM1	2	2	4,1	9	13,5	9	5,2	14	114090R	▲
RS114.1325.GM1	2,5	2,5	4,1	9	13,5	9	5,2	14	114090R	▲
LS114.0205.GM1	0,5	0,75	4,1	9	13,5	9	5,2	14	114090L	▲
LS114.0510.GM1	1	1,25	4,1	9	13,5	9	5,2	14	114090L	▲
LS114.0815.GM1	1,5	1,75	4,1	9	13,5	9	5,2	14	114090L	▲
LS114.1020.GM1	2	2	4,1	9	13,5	9	5,2	14	114090L	▲
LS114.1325.GM1	2,5	2,5	4,1	9	13,5	9	5,2	14	114090L	▲

P	●
M	o
K	o
N	-
S	-
H	-



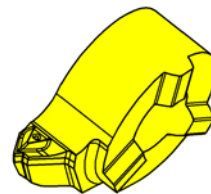
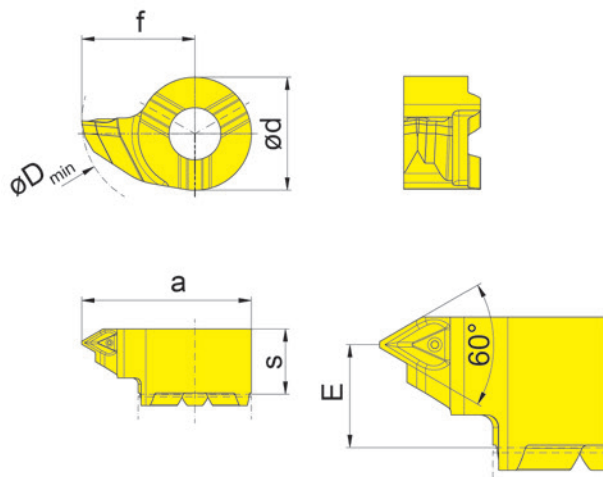

R = version à droite représentée  
R = versione destra come in figura

L = version à gauche  
L = versione sinistra a specchio

▲ en stock  
a stock

Nuance  
Leghe  
Δ 4 semaines  
4 settimane

Numéro de commande Codice prodotto	P	E	f	a	d	s	D <sub>min</sub>	HIS	EG55
RS114.0510.GM2	1	4,1	9	13,5	9	5,2	14	114090R	▲
RS114.0815.GM2	1,5	4,1	9	13,5	9	5,2	14	114090R	▲
RS114.1020.GM2	2	4,1	9	13,5	9	5,2	14	114090R	▲
RS114.1325.GM2	2,5	4,1	9	13,5	9	5,2	14	114090R	▲
LS114.0510.GM2	1	4,1	9	13,5	9	5,2	14	114090L	▲
LS114.0815.GM2	1,5	4,1	9	13,5	9	5,2	14	114090L	▲
LS114.1020.GM2	2	4,1	9	13,5	9	5,2	14	114090L	▲
LS114.1325.GM2	2,5	4,1	9	13,5	9	5,2	14	114090L	▲
	P	●							
	M	o							
	K	o							
	N	-							
	S	-							
	H	-							

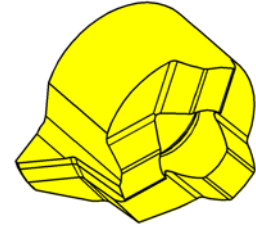
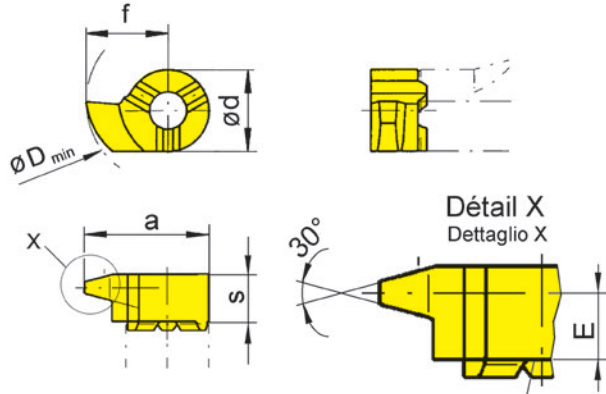

Profil frontal du porte outils  
Profilo frontale del portainsero

R = version à droite représentée  
R = versione destra come in figura

L = version à gauche  
L = versione sinistra a specchio

▲ en stock  
a stock

Nuance  
Leghe  
Δ 4 semaines  
4 settimane

Numéro de commande Codice prodotto	P	E	f	a	d	s	D <sub>min</sub>	HIS	Nuance Leghe	
									EG55	TN35
R114.1730.01	3	4,3	9	13,5	9	5,5	14	114090R	▲	▲
R114.2240.01	4	4	9	13,5	9	5,5	14	114090R	▲	▲
R114.2750.01	5	3,55	9	13,5	9	5,5	14	114090R	▲	▲
L114.2240.01	4	4	9	13,5	9	5,5	14	114090L	Δ	▲
L114.2750.01	5	3,55	9	13,5	9	5,5	14	114090L	Δ	▲
									P	● ●
									M	○ ●
									K	○ ●
									N	- ●
									S	- ●
									H	- -

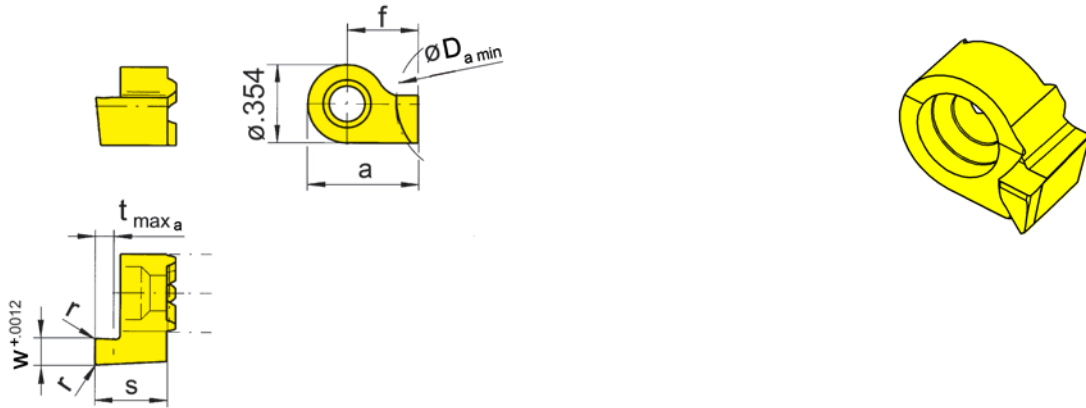
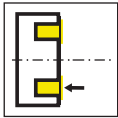

R = version à droite représentée  
R = versione destra come in figura

L = version à gauche  
L = versione sinistra a specchio

▲ en stock  
a stock

Nuance  
Leghe  
Δ 4 semaines  
4 settimane

Numéro de commande Codice prodotto	w	s	f	a	r	t <sub>max a</sub>	D <sub>a min</sub>	HIS		
									EG55	TN35
R114.1205.00	0,5	8,3	7,5	12	-	1	12	114090R	Δ	▲
R114.1210.00	1	8,3	7,5	12	-	1,5	12	114090R	▲	▲
R114.1215.00	1,5	8,3	7,5	12	0,2	2,5	12	114090R	▲	▲
R114.1220.00	2	8,3	7,5	12	0,2	3	12	114090R	▲	▲
R114.1225.00	2,5	8,3	7,5	12	0,2	3	12	114090R	▲	▲
R114.1230.00	3	8,3	7,5	12	0,2	3	12	114090R	▲	▲
R114.1220.5.00	2	10,8	7,5	12	0,2	5	12	114090R	▲	▲
R114.1225.5.00	2,5	10,8	7,5	12	0,2	5	12	114090R	▲	▲
R114.1230.6.00	3	11,8	7,5	12	0,2	6	12	114090R	▲	▲
L114.1205.00	0,5	8,3	7,5	12	-	1	12	114090L	Δ	▲
L114.1210.00	1	8,3	7,5	12	-	1,5	12	114090L	▲	▲
L114.1215.00	1,5	8,3	7,5	12	0,2	2,5	12	114090L	▲	▲
L114.1220.00	2	8,3	7,5	12	0,2	3	12	114090L	▲	▲
L114.1225.00	2,5	8,3	7,5	12	0,2	3	12	114090L	▲	▲
L114.1230.00	3	8,3	7,5	12	0,2	3	12	114090L	▲	▲
L114.1220.5.00	2	10,8	7,5	12	0,2	5	12	114090L	▲	▲
L114.1225.5.00	2,5	10,8	7,5	12	0,2	5	12	114090L	▲	▲
L114.1230.6.00	3	11,8	7,5	12	0,2	6	12	114090L	▲	▲

Usinage frontal le long d'un axe!  
Lavorazione oltre l'asse del pezzo

R = rotation antihoraire! Utiliser les plaquettes à gorges frontales type 114 sur les porte outils type B114 la cote l1 et l2 doivent être augmentées de 3,0 / 5,5 ou 6,5 mm.

R = rotazione senso antiorario! Utilizzando l'inserto tipo 114 per gole assiali con portainsero B114 le quote l1 e l2 devono essere incrementate di 3,0 / 5,5 o 6,5 mm.

P	●	●
M	○	●
K	○	●
N	-	●
S	-	●
H	-	-

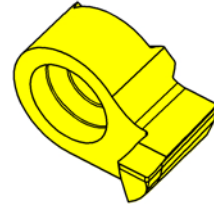
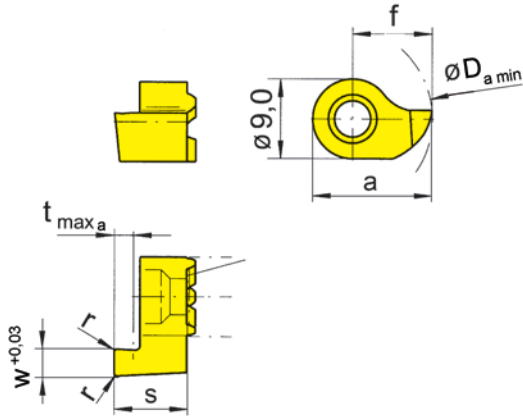
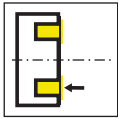

R = version à droite représentée  
R = versione destra come in figura

L = version à gauche  
L = versione sinistra a specchio

▲ en stock  
a stock

Nuance  
Leghe  
Δ 4 semaines  
4 settimane

Número de commande Codice prodotto	w	s	f	a	r	t <sub>max a</sub>	D <sub>a min</sub>	HIS	EG55	TN35
R114.1410.00	1	8,3	9	13,5	-	1,5	14	114090R	▲	▲
R114.1415.00	1,5	8,3	9	13,5	0,2	2,5	14	114090R	▲	▲
R114.1420.00	2	8,3	9	13,5	0,2	3	14	114090R	▲	▲
R114.1425.00	2,5	8,3	9	13,5	0,2	3	14	114090R	▲	▲
R114.1430.00	3	8,3	9	13,5	0,2	3	14	114090R	▲	▲
R114.1420.5.00	2	10,8	9	13,5	0,2	5	14	114090R	▲	▲
R114.1425.5.00	2,5	10,8	9	13,5	0,2	5	14	114090R	▲	▲
R114.1430.6.00	3	11,8	9	13,5	0,2	6	14	114090R	▲	▲
L114.1410.00	1	8,3	9	13,5	-	1,5	14	114090L	▲	▲
L114.1415.00	1,5	8,3	9	13,5	0,2	2,5	14	114090L	▲	▲
L114.1420.00	2	8,3	9	13,5	0,2	3	14	114090L	▲	▲
L114.1425.00	2,5	8,3	9	13,5	0,2	3	14	114090L	▲	▲
L114.1430.00	3	8,3	9	13,5	0,2	3	14	114090L	▲	▲
L114.1420.5.00	2	10,8	9	13,5	0,2	5	14	114090L	▲	▲
L114.1425.5.00	2,5	10,8	9	13,5	0,2	5	14	114090L	▲	▲
L114.1430.6.00	3	11,8	9	13,5	0,2	6	14	114090L	▲	▲

### Usinage frontal!

Lavorazione a cavallo del pezzo

R = rotation horaire! Utiliser les plaquettes à gorges frontales type 114 sur les porte outils type B114 la cote l1 et l2 doivent être augmentées de 3,0 / 5,5 ou 6,5 mm.

R = rotazione senso orario! Utilizzando l'inserto tipo 114 per gole assiali con portainsero B114 le quote l1 e l2 devono essere incrementate di 3,0 / 5,5 o 6,5 mm.

P	●	●
M	○	●
K	○	●
N	-	●
S	-	●
H	-	-



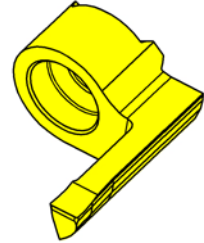
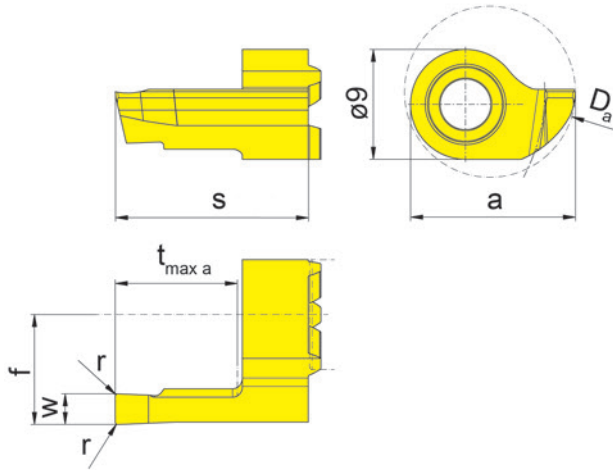
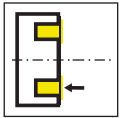

R = version à droite représentée  
R = versione destra come in figura

L = version à gauche  
L = versione sinistra a specchio

▲ en stock  
a stock

Nuance  
Leghe  
Δ 4 semaines  
4 settimane

Numéro de commande Codice prodotto	w	s	f	a	r	t <sub>max a</sub>	D <sub>a min</sub>	D <sub>a max</sub>	HIS	EG55
R114.1420.10.00	2	15,9	9	13,5	0,2	10	14	34	114090R	▲
R114.1425.10.00	2,5	15,9	9	13,5	0,2	10	14	35	114090R	▲
R114.1430.10.00	3	15,9	9	13,5	0,2	10	14	36	114090R	▲

**Usinage frontal!**

Lavorazione a cavallo del pezzo

R = rotation horaire! Utiliser les plaquettes à gorges frontales type 114 sur les porte outils type B114 la cote l1 et l2 doivent être augmentées de 3,0 / 5,5 / 6,5 ou 10,6 mm.

R = rotazione senso orario! Utilizzando l'inserto tipo 114 per gole assiali con portainsero B114 le quote l1 e l2 devono essere incrementate di 3,0 / 5,5 / 6,5 o 10,6 mm.

P	●
M	○
K	○
N	-
S	-
H	-

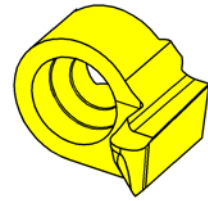
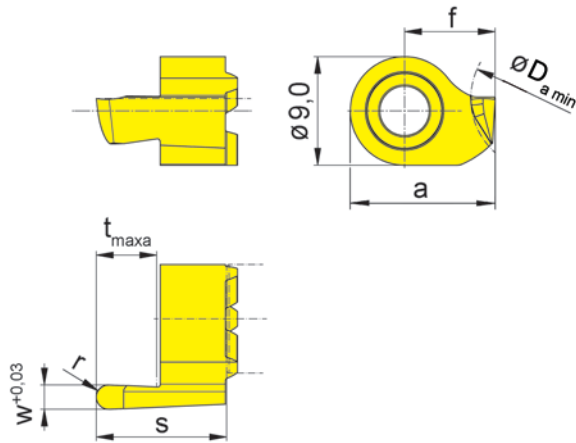
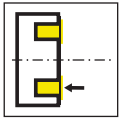

R = version à droite représentée  
R = versione destra come in figura

L = version à gauche  
L = versione sinistra a specchio

▲ en stock  
a stock

Nuance  
Leghe  
Δ 4 semaines  
4 settimane

Numéro de commande Codice prodotto	w	s	f	a	r	t <sub>max a</sub>	D <sub>a min</sub>	HIS	Nuance	
									EG55	TN35
R114.1220.5.10	2	10,8	7,5	12	1	5	12	114090R	▲	▲
R114.1225.5.12	2,5	10,8	7,5	12	1,25	5	12	114090R	▲	▲
R114.1230.6.15	3	11,8	7,5	12	1,5	6	12	114090R	▲	▲
L114.1220.5.10	2	10,8	7,5	12	1	5	12	114090L	▲	▲
L114.1225.5.12	2,5	10,8	7,5	12	1,25	5	12	114090L	▲	▲
L114.1230.6.15	3	11,8	7,5	12	1,5	6	12	114090L	▲	▲

Rayon complet Usinage frontal le long d'un axe!  
Raggio completo Lavorazione oltre l'asse del pezzo

R = rotation anti horaire! Utiliser les plaquettes à gorges frontales type 114 sur les porte outils type B114  
la cote l1 et l2 doivent êtres augmentées de 5,5 ou 6,5 mm.

R = rotazione anti-oraria! Utilizzando l'inserto per gole assiali tipo 114 sul portainsero tipo B114, la dimensione l1 e l2  
aumenteranno di 5,5 o 6,5 mm.

P	●	●
M	○	●
K	○	●
N	-	●
S	-	●
H	-	-

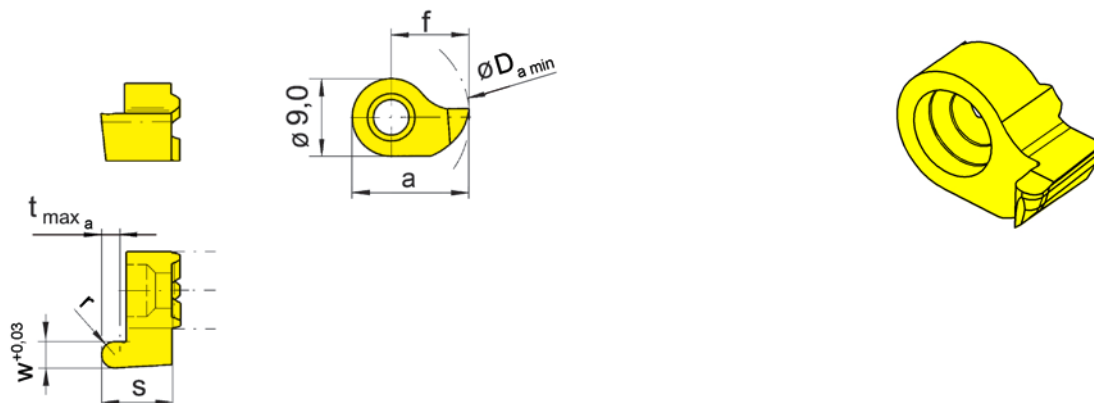
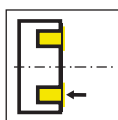

R = version à droite représentée  
R = versione destra come in figura

L = version à gauche  
L = versione sinistra a specchio

▲ en stock  
a stock

Nuance  
Leghe  
Δ 4 semaines  
4 settimane

Numéro de commande Codice prodotto	w	s	f	a	r	t <sub>max a</sub>	D <sub>a min</sub>	HIS	Nuance	
									EG55	TN35
R114.1410.05	1	8,3	9	13,5	0,5	1,5	14	114090R	▲	▲
R114.1416.08	1,6	8,3	9	13,5	0,8	2,5	14	114090R	▲	▲
R114.1420.10	2	8,3	9	13,5	1	3	14	114090R	▲	▲
R114.1425.12	2,5	8,3	9	13,5	1,25	3	14	114090R	▲	▲
R114.1430.15	3	8,3	9	13,5	1,5	3	14	114090R	▲	▲
R114.1420.5.10	2	8,3	9	13,5	1	5	14	114090R	▲	▲
R114.1425.5.12	2,5	8,3	9	13,5	1,25	5	14	114090R	▲	▲
R114.1430.6.15	3	8,3	9	13,5	1,5	6	14	114090R	▲	▲
L114.1410.05	1	8,3	9	13,5	0,5	1,5	14	114090L	▲	▲
L114.1416.08	1,6	8,3	9	13,5	0,8	2,5	14	114090L	▲	▲
L114.1420.10	2	8,3	9	13,5	1	3	14	114090L	▲	▲
L114.1425.12	2,5	8,3	9	13,5	1,25	3	14	114090L	▲	▲
L114.1430.15	3	8,3	9	13,5	1,5	3	14	114090L	Δ	▲
L114.1420.5.10	2	8,3	9	13,5	1	5	14	114090L	Δ	▲
L114.1425.5.12	2,5	8,3	9	13,5	1,25	5	14	114090L	Δ	▲
L114.1430.6.15	3	8,3	9	13,5	1,5	6	14	114090L	Δ	▲

Rayon complet **Usinage frontal!**  
Raggio completo Lavorazione a cavallo del pezzo

R = rotation horaire! Utiliser les plaquettes à gorges frontales type 114 sur les porte outils type B114 la cote l1 et l2 doivent être augmentées de 3,0 mm.

R = rotazione senso orario! Utilizzando l'inserto tipo 114 per gole assiali con portainsero B114 le quote l1 e l2 devono essere incrementate di 3,0 mm.

P	●	●
M	○	●
K	○	●
N	-	●
S	-	●
H	-	-

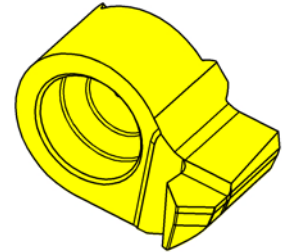
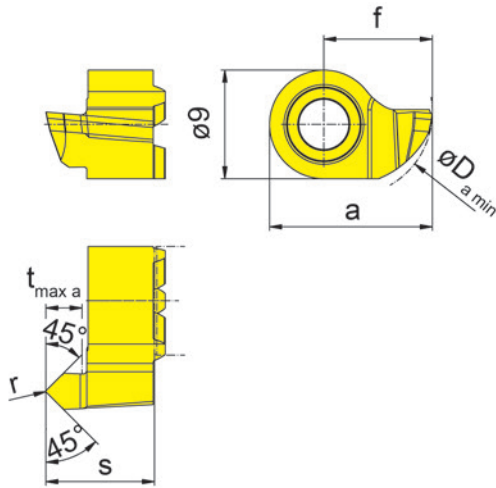
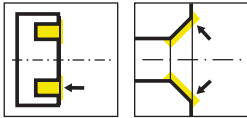

R = version à droite représentée  
R = versione destra come in figura

L = version à gauche  
L = versione sinistra a specchio

▲ en stock  
a stock

Nuance  
Leghe  
Δ 4 semaines  
4 settimane

Numéro de commande Codice prodotto	s	f	a	r	$t_{\max a}$	$D_{a \min}$	HIS	EG55
<b>R114.4545.14</b>	9	9	13,5	0,1	3	14	114090R	▲
<b>L114.4545.14</b>	9	9	13,5	0,1	3	14	114090L	Δ

**Usinage frontal!**

Lavorazione a cavallo del pezzo

R = rotation horaire! Utiliser les plaquettes à gorges frontales type 114 sur les porte outils type B114 la cote l1 et l2 doivent être augmentées de 3,0 / 5,5 ou 6,5 mm.

R = rotazione senso orario! Utilizzando l'inserto tipo 114 per gole assiali con portainsero B114 le quote l1 e l2 devono essere incrementate di 3,0 / 5,5 o 6,5 mm.

P	●
M	○
K	○
N	-
S	-
H	-



**116**



**Porte outils et plaquettes**

**Portainserito e inserti**

**K**

Porte outils  
Portainsero  
B116

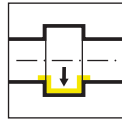

Page/Pag.  
334-335

Plaque de coupe  
Inserto  
116/S116



Page/Pag.  
336-337

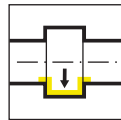

Page/Pag.  
338



Page/Pag.  
339

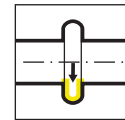

Page/Pag.  
340

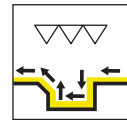

Page/Pag.  
341

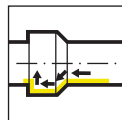

Page/Pag.  
342, 344-345



Page/Pag.  
343

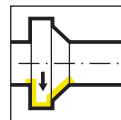

Page/Pag.  
346

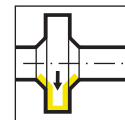

Page/Pag.  
347

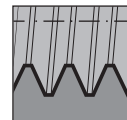

Page/Pag.  
348-353

Ø Alésage Foro Ø	Type de produit / Linea di prodotto											
	105	109	110	106	107	108	10P	111	11P	114	116	18P
≥ 0,2	•											
≥ 0,5	•											
≥ 0,7	•											
≥ 1,0	•											
≥ 1,5	•											
≥ 2,0	•											
≥ 3,0	•											
≥ 4,0	•											
≥ 5,0	•											
≥ 6,0	•	•	•	•								
≥ 6,8		•	•	•								
≥ 7,0		•			•							
≥ 7,8			•		•	•						
≥ 8,0			•		•	•						
≥ 9,0			•		•	•	•					
≥ 10,0			•				•	•	•			
≥ 10,5									•			
≥ 11,0								•	•			
≥ 11,5									•			
≥ 13,8										•		
≥ 14,0										•	•	
≥ 16,0											•	
≥ 16,5										(•)		
≥ 18,0												•
Profondeur de gorge Profondità della gola	2,5	2,5	4,0	0,8	2,0	1,0	3,0	2,3	3,5	4,0 (6,5)	4,3	8,0
Largeur de gorge Larghezza della gola	0,5- 2,0	1,0- 2,0	1,0- 3,0	0,7- 1,5	1,0- 2,0	0,7- 2,0	1,0- 3,0	0,7- 3,0	1,0- 3,0	0,7- 3,0	0,7- 4,0	2,0- 3,0
Usinage / Operazione												
Gorge Gole	•	•	•	•	•	•	•	•	•	•	•	•
Alésage Alesatura	•	•	•	•	•	•		•		•	•	
Filetage Filettatura	•	•			•	•		•		•	•	
Chanfreinage Smussatura	•	•			•	•		•		•	•	
Gorge frontale Gole assiali	•	•	•							•		
Alésage et Profil Alesatura e Profilatura	•											

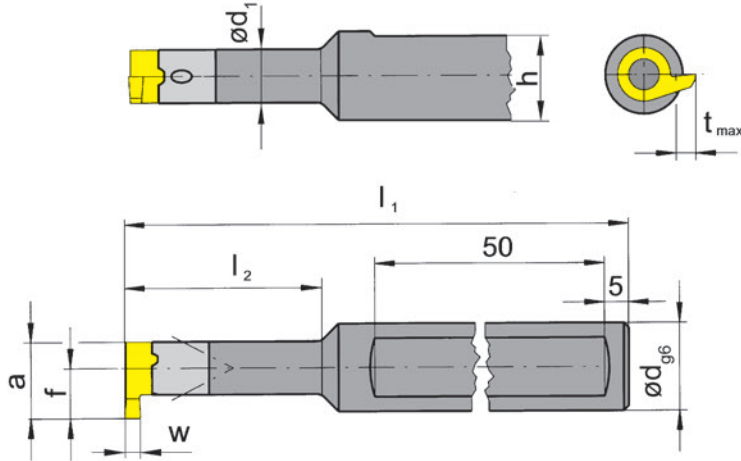
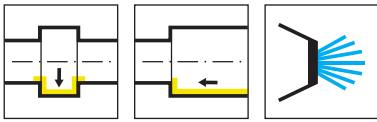

Illustration de coupe à droite représentée  
Figura = taglio destro

Numéro de commande Codice prodotto	d	$l_1$	$l_2$	h	$d_1$	HWS
B116.0012.01	12	130	40	11	11	116110R • 116110L
B116.0012.02	12	130	56	11	11	116110R • 116110L
B116.0012.03	12	150	80	11	11	116110R • 116110L
B116.0016.01	16	130	40	15	11	116110R • 116110L
B116.0016.02	16	130	56	15	11	116110R • 116110L
B116.0016.03	16	150	80	15	11	116110R • 116110L

w, a, tmax et f voir plaquettes  
w, a, tmax, f vd. Inserti

Pièces Détachées

Ricambi

Porte outils Portainsero	Vis de serrage Vite di serraggio	Tournevis TORX PLUS® Cacciavite TORX PLUS®
B116...	5.13T20EP	T20PQ

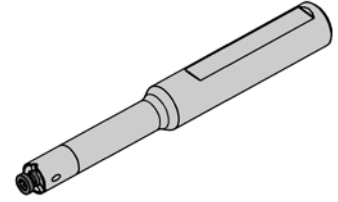
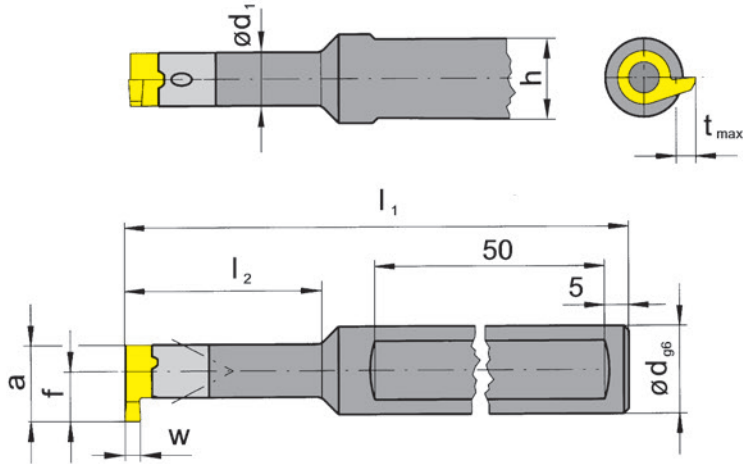
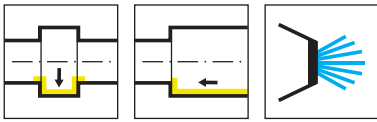

Illustration de coupe à droite représentée  
Figura = taglio destro

Numéro de commande Codice prodotto	d	$l_1$	$l_2$	h	$d_1$	HWS
B116.0012.2.01	12	130	40	11	11	116110R • 116110L
B116.0012.2.02	12	130	56	11	11	116110R • 116110L
B116.0012.2.03	12	150	80	11	11	116110R • 116110L
B116.0016.2.01	16	130	40	14	11	116110R • 116110L
B116.0016.2.02	16	130	56	14	11	116110R • 116110L
B116.0016.2.03	16	150	80	14	11	116110R • 116110L

w, a,  $t_{max}$  et f voir plaquettes  
w, a,  $t_{max}$ , f vd. Inserti

### Pièces Détachées

Ricambi

Porte outils Portainsero	Vis de serrage Vite di serraggio	Tournevis TORX PLUS® Cacciavite TORX PLUS®
B116...	5.13T20EP	T20PQ

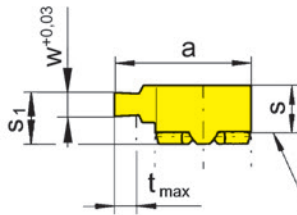
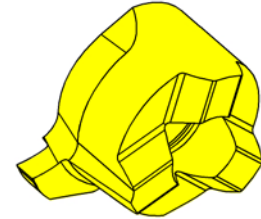
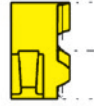
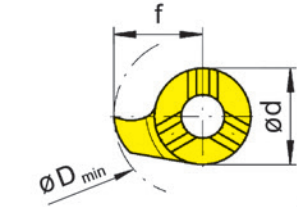
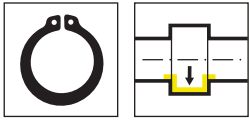

Profil frontal du porte outils  
Profilo frontale del portainsero

R = version à droite représentée  
R = versione destra come in figura

L = version à gauche  
L = versione sinistra a specchio

▲ en stock  
a stock

Nuance  
Leghe  
Δ 4 semaines  
4 settimane

Numéro de commande Codice prodotto	w	Nw	s	f	a	s <sub>1</sub>	d	t <sub>max</sub>	D <sub>min</sub>	HIS	Nuance Leghe	
											EG55	TN35
R116.0070.00	0,74	0,7	5,5	10,2	15,7	5,3	11	1,2	16	116110R	▲	▲
R116.0080.00	0,84	0,8	5,5	10,2	15,7	5,3	11	1,3	16	116110R	▲	▲
R116.0090.00	0,94	0,9	5,5	10,2	15,7	5,3	11	1,5	16	116110R	▲	▲
L116.0070.00	0,74	0,7	5,5	10,2	15,7	5,3	11	1,2	16	116110L	Δ	▲
L116.0080.00	0,84	0,8	5,5	10,2	15,7	5,3	11	1,3	16	116110L	Δ	Δ
L116.0090.00	0,94	0,9	5,5	10,2	15,7	5,3	11	1,5	16	116110L	Δ	▲

Profondeur de coupe limitée  
Profondità di taglio limitata

Largeurs pour gorges circlips DIN 471/472  
Larghezza per esecuzione anelli Seeger DIN 471/472

	EG55	TN35
P	●	●
M	○	●
K	○	●
N	-	●
S	-	●
H	-	-

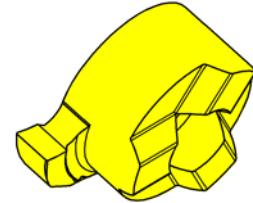
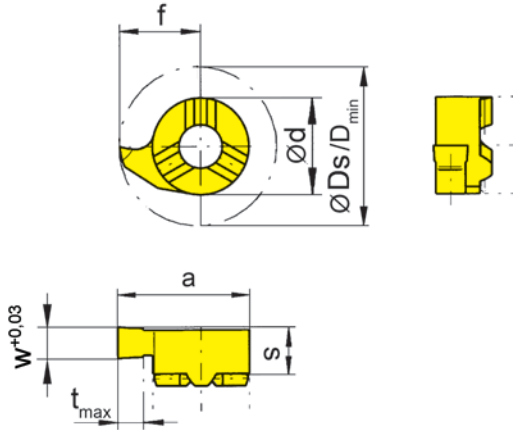
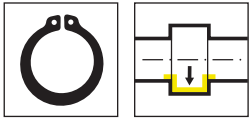

R = version à droite représentée  
R = versione destra come in figura

L = version à gauche  
L = versione sinistra a specchio

▲ en stock  
a stock

Nuance  
Leghe  
Δ 4 semaines  
4 settimane

Numéro de commande Codice prodotto	w	Nw	s	f	Ds	a	d	t <sub>max</sub>	D <sub>min</sub>	Z	HIS	Nuance Leghe			
												EG55	TH35	TN35	
<b>R116.0110.00</b>	1,19	1,1	5,3	10,2	20,4	15,7	11	4,3	16	1	116110R	▲	▲	▲	
<b>R116.0130.00</b>	1,39	1,3	5,3	10,2	20,4	15,7	11	4,3	16	1	116110R	▲	▲	▲	
<b>R116.0160.00</b>	1,69	1,6	5,3	10,2	20,4	15,7	11	4,3	16	1	116110R	▲	▲	▲	
<b>L116.0110.00</b>	1,19	1,1	5,3	10,2	20,4	15,7	11	4,3	16	1	116110L		▲	▲	
<b>L116.0130.00</b>	1,39	1,3	5,3	10,2	20,4	15,7	11	4,3	16	1	116110L		▲	▲	
<b>L116.0160.00</b>	1,69	1,6	5,3	10,2	20,4	15,7	11	4,3	16	1	116110L		▲	▲	
												<b>P</b>	●	●	●
												<b>M</b>	○	●	●
												<b>K</b>	○	●	●
												<b>N</b>	-	●	●
												<b>S</b>	-	●	●
												<b>H</b>	-	-	-

Largeurs pour gorges circlips DIN 471/472  
Larghezza per esecuzione anelli Seeger DIN 471/472

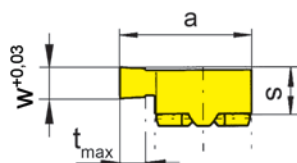
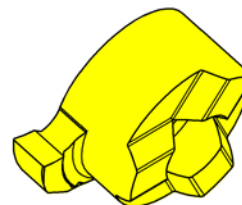
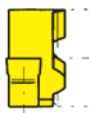
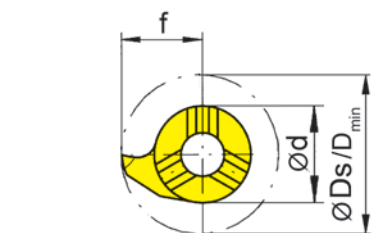
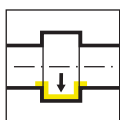

R = version à droite représentée  
R = versione destra come in figura

L = version à gauche  
L = versione sinistra a specchio

▲ en stock  
a stock

Nuance  
Leghe  
Δ 4 semaines  
4 settimane

Numéro de commande Codice prodotto	w	s	f	Ds	a	d	t <sub>max</sub>	D <sub>min</sub>	Z	HIS	Nuance Leghe		
											EG55	TH35	TN35
R116.0200.00	2	5,3	10,2	20,4	15,7	11	4,3	16	1	116110R	▲	▲	▲
R116.0250.00	2,5	5,3	10,2	20,4	15,7	11	4,3	16	1	116110R	▲	▲	▲
R116.0300.00	3	5,3	10,2	20,4	15,7	11	4,3	16	1	116110R	▲	▲	▲
R116.0350.00	3,5	5,3	10,2	20,4	15,7	11	4,3	16	1	116110R	▲	▲	▲
R116.0400.00	4	5,3	10,2	20,4	15,7	11	4,3	16	1	116110R	▲	▲	▲
L116.0200.00	2	5,3	10,2	20,4	15,7	11	4,3	16	1	116110L	▲	▲	▲
L116.0250.00	2,5	5,3	10,2	20,4	15,7	11	4,3	16	1	116110L	▲	▲	▲
L116.0300.00	3	5,3	10,2	20,4	15,7	11	4,3	16	1	116110L	▲	▲	▲
L116.0350.00	3,5	5,3	10,2	20,4	15,7	11	4,3	16	1	116110L	▲	▲	▲
L116.0400.00	4	5,3	10,2	20,4	15,7	11	4,3	16	1	116110L	▲	▲	▲
P											●	●	●
M											○	●	●
K											○	●	●
N											-	●	●
S											-	●	●
H											-	-	-

# Plaque de coupe

Inserto

# S116

$\varnothing \geq 16$  mm

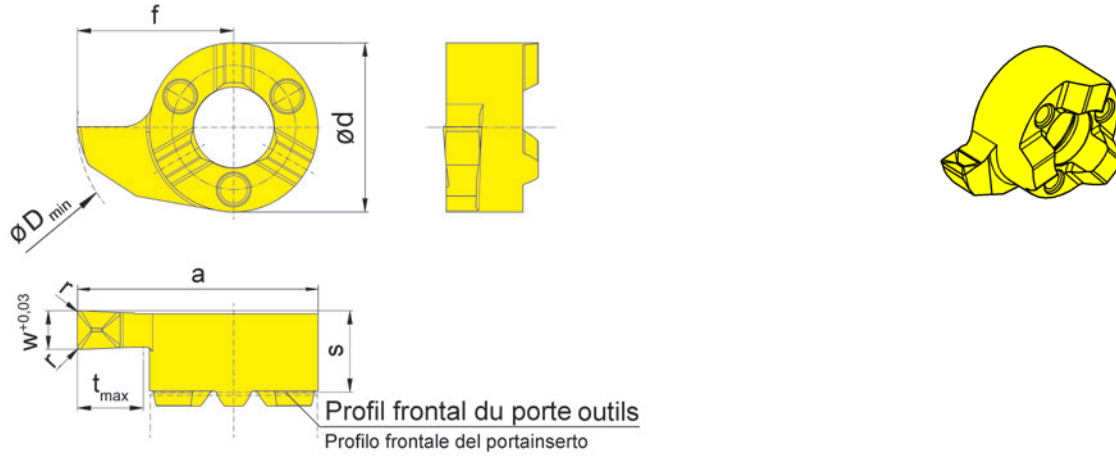
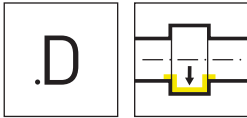

R = version à droite représentée  
R = versione destra come in figura

L = version à gauche  
L = versione sinistra a specchio

▲ en stock  
a stock

Nuance  
Leghe  
Δ 4 semaines  
4 settimane

Numéro de commande Codice prodotto	w	s	f	a	r	d	t <sub>max</sub>	D <sub>min</sub>	HIS	Nuance Leghe	
										EG55	TH35
RS116.0200.D2	2	5,3	10,2	15,7	0,2	11	4,3	16	116110R	▲	▲
RS116.0250.D2	2,5	5,3	10,2	15,7	0,2	11	4,3	16	116110R	▲	▲
RS116.0300.D2	3	5,3	10,2	15,7	0,2	11	4,3	16	116110R	▲	▲
LS116.0200.D2	2	5,3	10,2	15,7	0,2	11	4,3	16	116110L		▲
LS116.0250.D2	2,5	5,3	10,2	15,7	0,2	11	4,3	16	116110L		▲
LS116.0300.D2	3	5,3	10,2	15,7	0,2	11	4,3	16	116110L	Δ	▲
										P	●
										M	○
										K	○
										N	-
										S	-
										H	-

K

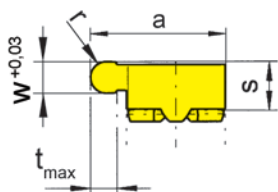
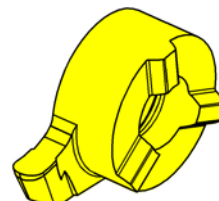
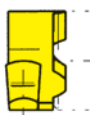
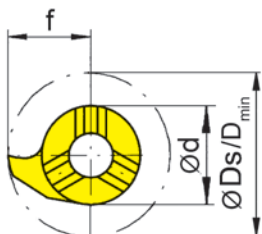
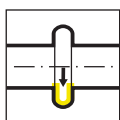

R = version à droite représentée  
R = versione destra come in figura

L = version à gauche  
L = versione sinistra a specchio

▲ en stock  
a stock

Nuance  
Leghe  
Δ 4 semaines  
4 settimane

Numéro de commande Codice prodotto	w	s	f	Ds	a	r	d	t <sub>max</sub>	D <sub>min</sub>	Z	HIS	Nuance Leghe		
												EG55	TH35	TN35
R116.0009.18	1,8	5,3	10,2	20,4	15,7	0,9	11	4,3	16	1	116110R	▲	▲	▲
R116.0011.22	2,2	5,3	10,2	20,4	15,7	1,1	11	4,3	16	1	116110R	▲	▲	▲
R116.0015.30	3	5,3	10,2	20,4	15,7	1,5	11	4,3	16	1	116110R	▲	▲	▲
R116.0020.40	4	5,3	10,2	20,4	15,7	2	11	4,3	16	1	116110R	▲	▲	▲
L116.0009.18	1,8	5,3	10,2	20,4	15,7	0,9	11	4,3	16	1	116110L	▲	▲	▲
L116.0011.22	2,2	5,3	10,2	20,4	15,7	1,1	11	4,3	16	1	116110L	▲	▲	▲
L116.0015.30	3	5,3	10,2	20,4	15,7	1,5	11	4,3	16	1	116110L	▲	▲	▲
L116.0020.40	4	5,3	10,2	20,4	15,7	2	11	4,3	16	1	116110L	▲	▲	▲
P	●	●	●											
M	○	●	●											
K	○	●	●											
N	-	●	●											
S	-	●	●											
H	-	-	-											

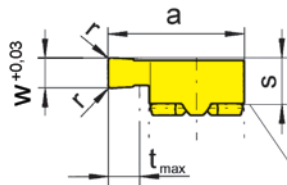
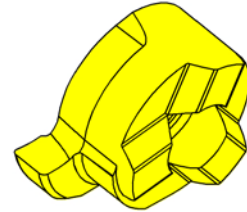
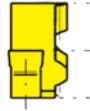
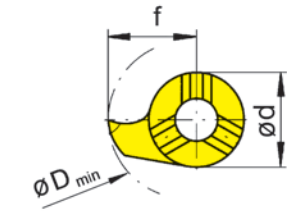
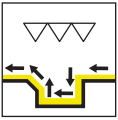

Profil frontal du porte outils  
Profilo frontale del portainsero

R = version à droite représentée  
R = versione destra come in figura

L = version à gauche  
L = versione sinistra a specchio

▲ en stock  
a stock

Nuance  
Leghe  
Δ 4 semaines  
4 settimane

Numéro de commande Codice prodotto	w	s	f	a	r	d	t <sub>max</sub>	D <sub>min</sub>	HIS	Nuance Leghe			
										EG55	TH35	TN35	
R116.0200.02	2	5,3	10,2	15,7	0,2	11	4,3	16	116110R	▲	▲	▲	
L116.0200.02	2	5,3	10,2	15,7	0,2	11	4,3	16	116110L	▲	▲	▲	
										P	●	●	●
										M	○	●	●
										K	○	●	●
										N	-	●	●
										S	-	●	●
										H	-	-	-

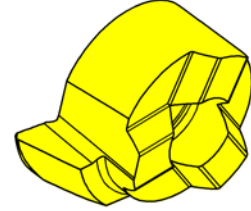
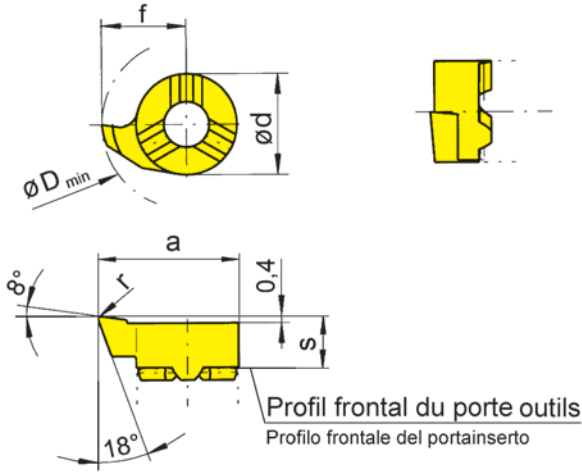
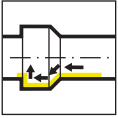

R = version à droite représentée  
R = versione destra come in figura

L = version à gauche  
L = versione sinistra a specchio

▲ en stock  
a stock

Nuance  
Leghe  
Δ 4 semaines  
4 settimane

Numéro de commande Codice prodotto	s	f	a	r	d	D <sub>min</sub>	HIS	Nuance Leghe			
								EG55	TH35	TN35	
R116.1897.02	5,3	9,7	15,2	0,2	11	15,5	116110R	▲	▲	▲	
L116.1897.02	5,3	9,7	15,2	0,2	11	15,5	116110L	▲	▲	▲	
								P	●	●	●
								M	○	●	●
								K	○	●	●
								N	-	●	●
								S	-	●	●
								H	-	-	-

# Plaquette de coupe

Inserto

# S116

$\varnothing \geq 15,5 \text{ mm}$

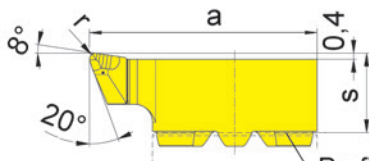
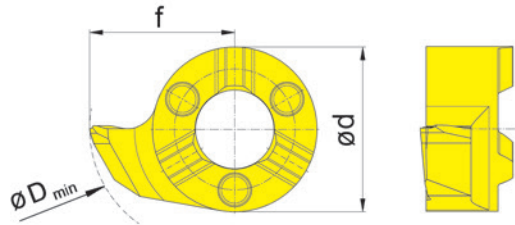
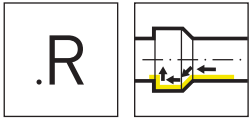

Profil frontal du porte outils  
Profilo frontale del portainsero

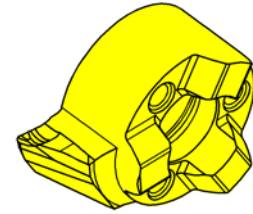

R = version à droite représentée  
R = versione destra come in figura

L = version à gauche  
L = versione sinistra a specchio

▲ en stock  
a stock

Nuance  
Leghe  
Δ 4 semaines  
4 settimane

Numéro de commande Codice prodotto	s	f	a	r	d	D <sub>min</sub>	HIS	Nuance Leghe	
								EG55	TH35
RS116.1897.R2	5,3	9,7	15,2	0,2	11	15,5	116110R	▲	▲
RS116.1897.R4	5,3	9,7	15,2	0,4	11	15,5	116110R	▲	▲
LS116.1897.R2	5,3	9,7	15,2	0,2	11	15,5	116110L	▲	▲
LS116.1897.R4	5,3	9,7	15,2	0,4	11	15,5	116110L	▲	▲
								P	● ●
								M	○ ●
								K	○ ●
								N	- ●
								S	- ●
								H	- -

K

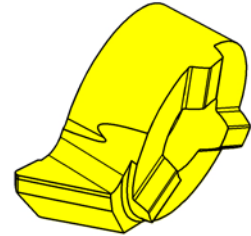
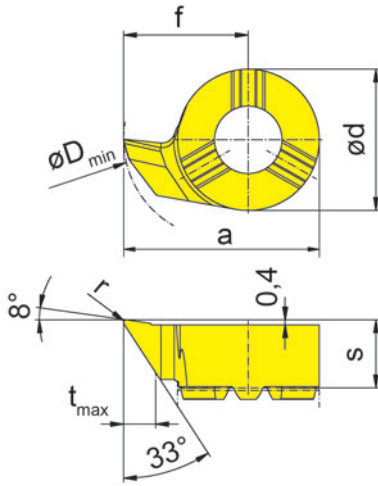
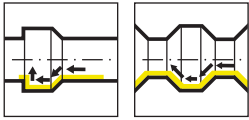

R = version à droite représentée  
R = versione destra come in figura

L = version à gauche  
L = versione sinistra a specchio

▲ en stock  
a stock

Nuance  
Leghe  
Δ 4 semaines  
4 settimane

Numéro de commande Codice prodotto	s	f	a	r	d	t <sub>max</sub>	D <sub>min</sub>	HIS	EG55
R116.3302.02	5,3	9,7	15,2	0,2	11	2,5	15,5	116110R	▲
R116.3302.04	5,3	9,7	15,2	0,4	11	2,5	15,5	116110R	▲
L116.3302.02	5,3	9,7	15,2	0,2	11	2,5	15,5	116110L	Δ
L116.3302.04	5,3	9,7	15,2	0,4	11	2,5	15,5	116110L	Δ
									P ●
									M ○
									K ○
									N -
									S -
									H -

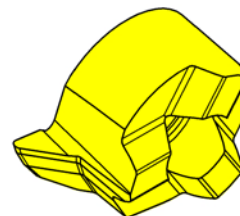
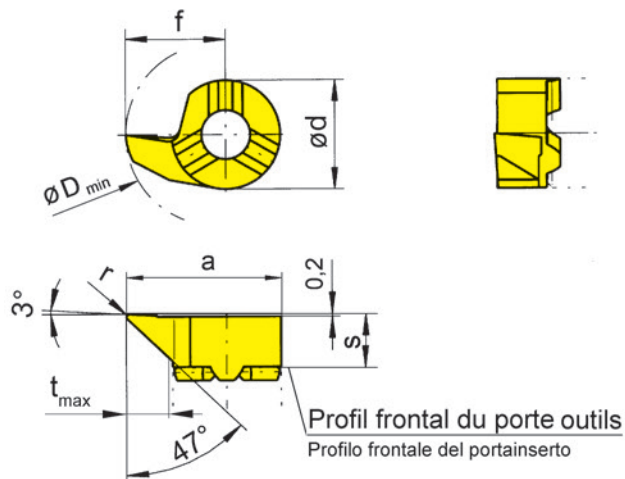
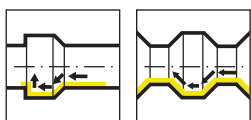

R = version à droite représentée  
R = versione destra come in figura

L = version à gauche  
L = versione sinistra a specchio

▲ en stock  
a stock

Nuance  
Leghe  
Δ 4 semaines  
4 settimane

Numéro de commande Codice prodotto	s	f	a	r	d	t <sub>max</sub>	D <sub>min</sub>	HIS	Nuance Leghe		
									EG55	TH35	TN35
R116.4702.02	5,3	10,2	15,7	0,2	11	4,3	16	116110R	▲	▲	▲
R116.4702.04	5,3	10,2	15,7	0,4	11	4,3	16	116110R	▲	▲	▲
L116.4702.02	5,3	10,2	15,7	0,2	11	4,3	16	116110L	▲	▲	▲
L116.4702.04	5,3	10,2	15,7	0,4	11	4,3	16	116110L	▲	▲	▲
P	●	●	●	●	●	●	●	●	●	●	●
M	○	○	○	○	○	○	○	○	○	○	○
K	○	○	○	○	○	○	○	○	○	○	○
N	-	●	●	●	●	●	●	●	●	●	●
S	-	●	●	●	●	●	●	●	●	●	●
H	-	-	-	-	-	-	-	-	-	-	-

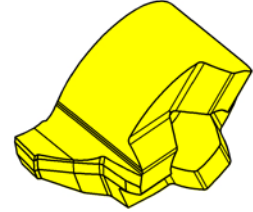
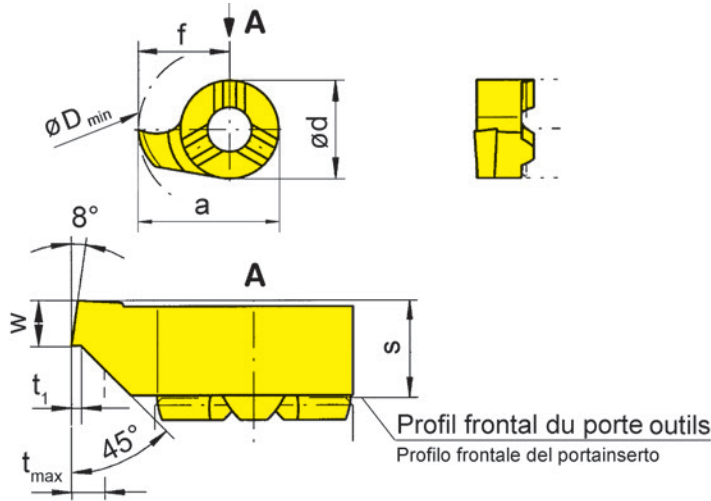
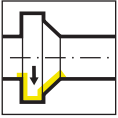

R = version à droite représentée  
R = versione destra come in figura

L = version à gauche  
L = versione sinistra a specchio

▲ en stock  
a stock

Nuance  
Leghe  
Δ 4 semaines  
4 settimane

Numéro de commande Codice prodotto	w	s	f	a	d	t <sub>max</sub>	t <sub>1</sub>	D <sub>min</sub>	HIS	Nuance Leghe	
										EG55	TI25
R116.0815.45	1,5	5,3	10,2	15,7	11	1,5	0,2	16	116110R	▲	▲
L116.0815.45	1,5	5,3	10,2	15,7	11	1,5	0,2	16	116110L	▲	▲
										P	● ●
										M	○ ●
										K	○ ●
										N	- ●
										S	- ●
										H	- -

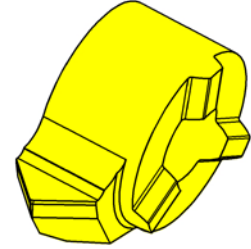
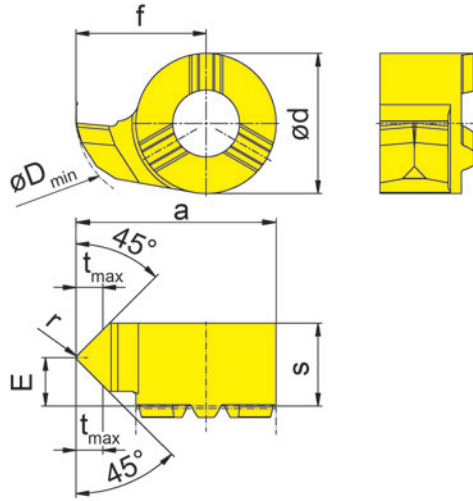
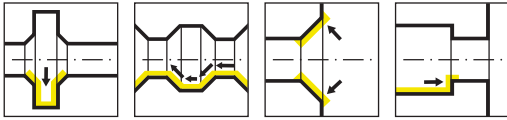

R = version à droite représentée  
R = versione destra come in figura

L = version à gauche  
L = versione sinistra a specchio

▲ en stock  
a stock

Nuance  
Leghe  
Δ 4 semaines  
4 settimane

Numéro de commande Codice prodotto	E	s	f	a	r	d	t <sub>max</sub>	D <sub>min</sub>	HIS	EG55
R116.4545.02	3,8	6,5	10,2	15,7	0,2	11	2,1	16	116110R	▲
L116.4545.02	3,8	6,5	10,2	15,7	0,2	11	2,1	16	116110L	Δ
										P ●
										M ○
										K ○
										N -
										S -
										H -

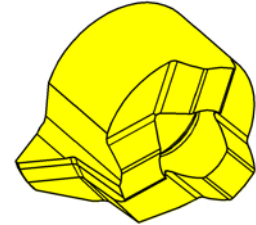
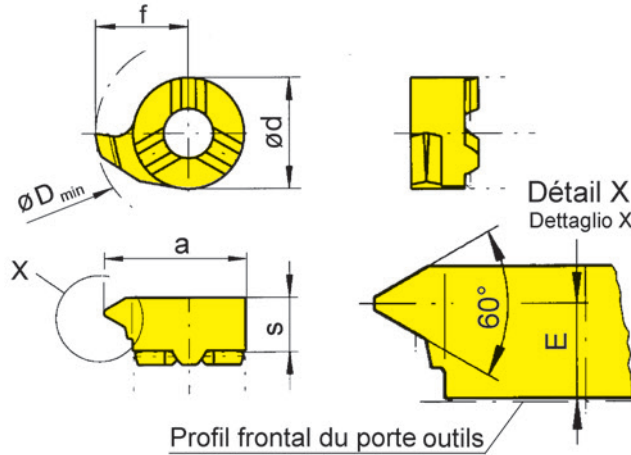

Profil frontal du porte outils  
Profilo frontale del portainserito

R = version à droite représentée  
R = versione destra come in figura

L = version à gauche  
L = versione sinistra a specchio

▲ en stock  
a stock

Nuance  
Leghe  
△ 4 semaines  
4 settimane

Numéro de commande Codice prodotto	P	P <sub>max</sub>	E	f	a	d	s	D <sub>min</sub>	HIS	Nuance Leghe			
										EG55	TH35	TN35	
R116.0510.01	1	1,25	4,7	10,2	15,7	11	5,5	16	116110R	▲	▲	▲	
R116.0815.01	1,5	1,75	4,5	10,2	15,7	11	5,5	16	116110R	▲	▲	▲	
R116.1020.01	2		4,3	10,2	15,7	11	5,5	16	116110R	▲	▲	▲	
R116.1325.01	2,5		4,2	10,2	15,7	11	5,5	16	116110R	▲	▲	▲	
L116.0510.01	1	1,25	4,7	10,2	15,7	11	5,5	16	116110L	△		△	
L116.0815.01	1,5	1,75	4,5	10,2	15,7	11	5,5	16	116110L	△	△	▲	
L116.1020.01	2		4,3	10,2	15,7	11	5,5	16	116110L	△	△	▲	
L116.1325.01	2,5		4,2	10,2	15,7	11	5,5	16	116110L	△	▲	▲	
										P	●	●	●
										M	○	●	●
										K	○	●	●
										N	-	●	●
										S	-	●	●
										H	-	-	-

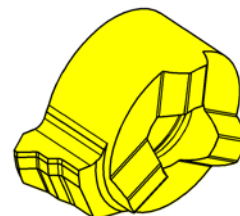
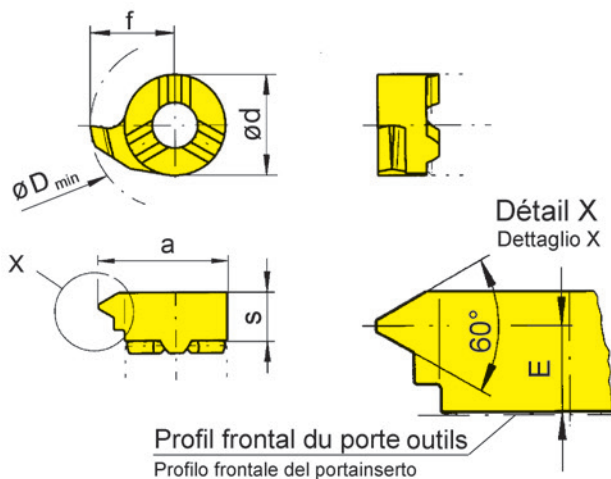

R = version à droite représentée  
R = versione destra come in figura

L = version à gauche  
L = versione sinistra a specchio

▲ en stock  
a stock

Nuance  
Leghe  
Δ 4 semaines  
4 settimane

Numéro de commande Codice prodotto	P	E	f	a	d	s	D <sub>min</sub>	HIS	Nuance Leghe	
									EG55	TN35
R116.0510.02	1	4,7	10,2	15,7	11	5,5	16	116110R	▲	▲
R116.0815.02	1,5	4,5	10,2	15,7	11	5,5	16	116110R	▲	▲
R116.1020.02	2	4,3	10,2	15,7	11	5,5	16	116110R	▲	▲
R116.1325.02	2,5	4,2	10,2	15,7	11	5,5	16	116110R	▲	▲
R116.1630.02	3	4	10,2	15,7	11	5,5	16	116110R	▲	▲
R116.1835.02	3,5	3,8	10,2	15,7	11	5,5	16	116110R	▲	▲
R116.2140.02	4	3,6	10,2	15,7	11	5,5	16	116110R	▲	▲
L116.0510.02	1	4,7	10,2	15,7	11	5,5	16	116110L	▲	Δ
L116.0815.02	1,5	4,5	10,2	15,7	11	5,5	16	116110L	Δ	▲
L116.1020.02	2	4,3	10,2	15,7	11	5,5	16	116110L	Δ	▲
L116.1325.02	2,5	4,2	10,2	15,7	11	5,5	16	116110L	Δ	▲
L116.1630.02	3	4	10,2	15,7	11	5,5	16	116110L	▲	▲
L116.1835.02	3,5	3,8	10,2	15,7	11	5,5	16	116110L	Δ	▲
L116.2140.02	4	3,6	10,2	15,7	11	5,5	16	116110L	Δ	Δ
									P	● ●
									M	o ●
									K	o ●
									N	- ●
									S	- ●
									H	- -

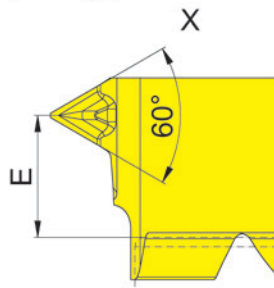
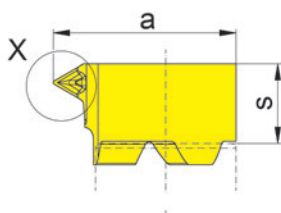
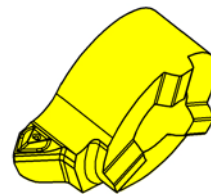
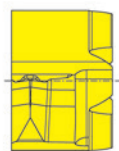
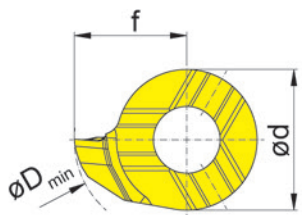

L = version à gauche représentée  
L = versione sinistra come in figura

▲ en stock  
a stock

Nuance  
Leghe  
Δ 4 semaines  
4 settimane

Numéro de commande Codice prodotto	P	P <sub>max</sub>	E	f	a	d	s	D <sub>min</sub>	HIS	EG55
RS116.0510.GM1	1	1,25	4,1	10,2	15,7	11	5,2	16	116110R	▲
RS116.0815.GM1	1,5	1,75	4,1	10,2	15,7	11	5,2	16	116110R	▲
RS116.1020.GM1	2	2	4,1	10,2	15,7	11	5,2	16	116110R	▲
RS116.1325.GM1	2,5	2,5	4,1	10,2	15,7	11	5,2	16	116110R	▲
LS116.0510.GM1	1	1,25	4,1	10,2	15,7	11	5,2	16	116110L	▲
LS116.0815.GM1	1,5	1,75	4,1	10,2	15,7	11	5,2	16	116110L	▲
LS116.1020.GM1	2	2	4,1	10,2	15,7	11	5,2	16	116110L	▲
LS116.1325.GM1	2,5	2,5	4,1	10,2	15,7	11	5,2	16	116110L	▲
	P	●								
	M	o								
	K	o								
	N	-								
	S	-								
	H	-								

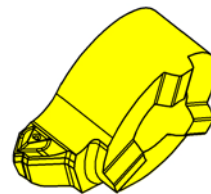
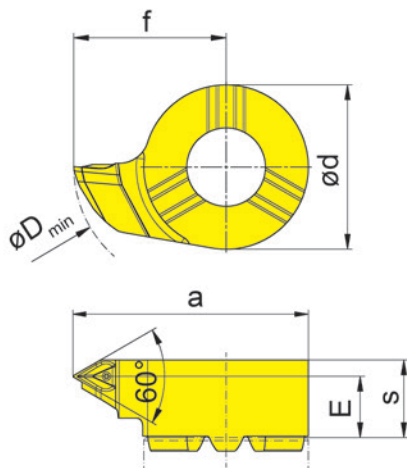

L = version à gauche représentée  
L = versione sinistra come in figura

Nuance  
Leghe  
▲ en stock     Δ 4 semaines  
a stock             4 settimane

Numéro de commande Codice prodotto	P	E	f	a	d	s	D <sub>min</sub>	HIS	EG55
RS116.0510.GM2	1	4,1	10,2	15,7	11	5,2	16	116110R	▲
RS116.0815.GM2	1,5	4,1	10,2	15,7	11	5,2	16	116110R	▲
RS116.1020.GM2	2	4,1	10,2	15,7	11	5,2	16	116110R	▲
RS116.1325.GM2	2,5	4,1	10,2	15,7	11	5,2	16	116110R	▲
LS116.0510.GM2	1	4,1	10,2	15,7	11	5,2	16	116110L	▲
LS116.0815.GM2	1,5	4,1	10,2	15,7	11	5,2	16	116110L	▲
LS116.1020.GM2	2	4,1	10,2	15,7	11	5,2	16	116110L	▲
LS116.1325.GM2	2,5	4,1	10,2	15,7	11	5,2	16	116110L	▲
	P	●							
	M	o							
	K	o							
	N	-							
	S	-							
	H	-							

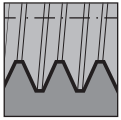

BSW  
BSF

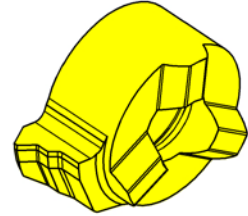
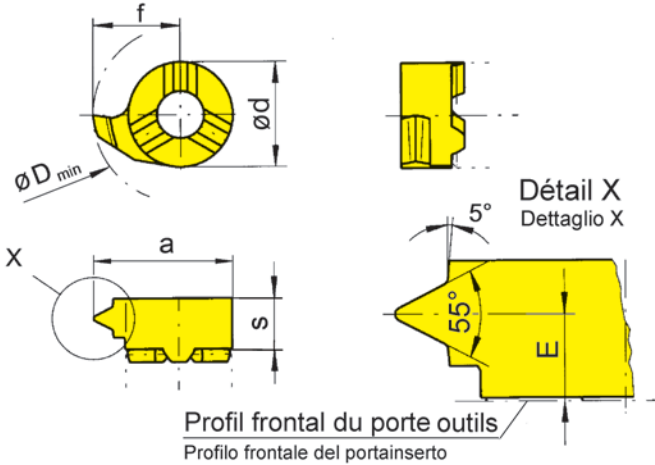

R = version à droite représentée  
R = versione destra come in figura

L = version à gauche  
L = versione sinistra a specchio

▲ en stock  
a stock

Nuance  
Leghe  
Δ 4 semaines  
4 settimane

Numéro de commande Codice prodotto	TPI	E	f	d	s	D <sub>min</sub>	HIS	Nuance Leghe		
								EG55	TN35	
R116.5511.02	11	3,5	10,2	11	5,5	16	116110R	▲	▲	
R116.5514.02	14	3,9	10,2	11	5,5	16	116110R	▲	▲	
L116.5511.02	11	3,5	10,2	11	5,5	16	116110L	Δ	Δ	
L116.5514.02	14	3,9	10,2	11	5,5	16	116110L	Δ	▲	
								P	●	●
								M	○	●
								K	○	●
								N	-	●
								S	-	●
								H	-	-

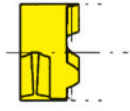
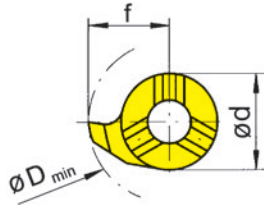

Détail X  
Dettaglio X

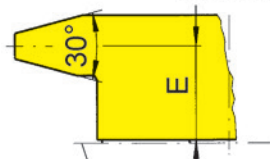
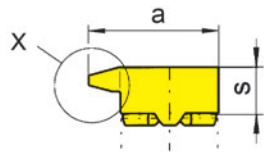

Profil frontal du porte outils  
Profilo frontale del portainsero

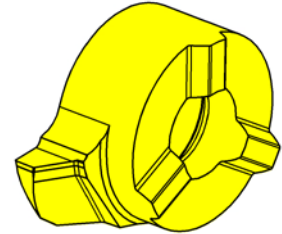

R = version à droite représentée  
R = versione destra come in figura

L = version à gauche  
L = versione sinistra a specchio

▲ en stock  
a stock

Nuance  
Leghe  
Δ 4 semaines  
4 settimane

Numéro de commande Codice prodotto	P	E	f	a	d	s	D <sub>min</sub>	Filetage Filettatura	HIS	Nuance Leghe		
										EG55	TI25	TN35
R116.1220.01	2	4,5	9,7	15,2	11	5,5	16	Tr 20x2	116110R	▲		▲
R116.1730.01	3	4,3	9,7	15,2	11	5,5	16	Tr 22x3	116110R	▲		▲
R116.2240.01	4	4	9,7	15,2	11	5,5	16	Tr 22x4	116110R	▲		▲
R116.2750.01	5	3,55	10,2	15,7	11	5,5	16	Tr 24x5	116110R	▲		▲
R116.3560.01	6	3,3	10,2	15,7	11	5,5	16	Tr 30x6	116110R	▲	▲	
L116.1220.01	2	4,5	9,7	15,2	11	5,5	16	Tr 20x2	116110L	Δ		Δ
L116.1730.01	3	4,3	9,7	15,2	11	5,5	16	Tr 22x3	116110L	▲		▲
L116.2240.01	4	4	9,7	15,2	11	5,5	16	Tr 22x4	116110L	▲		▲
L116.2750.01	5	3,55	10,2	15,7	11	5,5	16	Tr 24x5	116110L	▲		▲
L116.3560.01	6	3,3	10,2	15,7	11	5,5	16	Tr 30x6	116110L	▲	▲	
P										●	●	●
M										○	●	●
K										○	●	●
N										-	●	●
S										-	●	●
H										-	-	-



K

**18P**



**Porte outils et plaquettes**

**Portainserito e inserti**

**L**

Porte outils  
Portainsero  
B18P

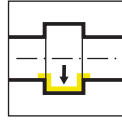

Page/Pag.  
358

Plaque de coupe  
Inserto  
S18P/18P



Page/Pag.  
359, 361

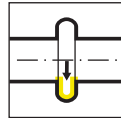

Page/Pag.  
360



Page/Pag.  
362

Ø Alésage Foro Ø	Type de produit / Linea di prodotto											
	105	109	110	106	107	108	10P	111	11P	114	116	18P
≥ 0,2	•											
≥ 0,5	•											
≥ 0,7	•											
≥ 1,0	•											
≥ 1,5	•											
≥ 2,0	•											
≥ 3,0	•											
≥ 4,0	•											
≥ 5,0	•											
≥ 6,0	•	•	•	•								
≥ 6,8		•	•	•								
≥ 7,0		•			•							
≥ 7,8			•		•	•						
≥ 8,0			•		•	•						
≥ 9,0			•		•	•	•					
≥ 10,0			•				•	•	•			
≥ 10,5									•			
≥ 11,0								•	•			
≥ 11,5									•			
≥ 13,8										•		
≥ 14,0										•	•	
≥ 16,0											•	
≥ 16,5										{•}		
≥ 18,0												•
Profondeur de gorge Profondità della gola	2,5	2,5	4,0	0,8	2,0	1,0	3,0	2,3	3,5	4,0 (6,5)	4,3	8,0
Largeur de gorge Larghezza della gola	0,5- 2,0	1,0- 2,0	1,0- 3,0	0,7- 1,5	1,0- 2,0	0,7- 2,0	1,0- 3,0	0,7- 3,0	1,0- 3,0	0,7- 3,0	0,7- 4,0	2,0- 3,0
Usinage / Operazione												
Gorge Gole	•	•	•	•	•	•	•	•	•	•	•	•
Alésage Alesatura	•	•	•	•	•	•			•		•	•
Filetage Filettatura	•	•			•	•			•		•	•
Chanfreinage Smussatura	•	•			•	•			•		•	•
Gorge frontale Gole assiali	•	•	•									
Alésage et Profil Alesatura e Profilatura	•											



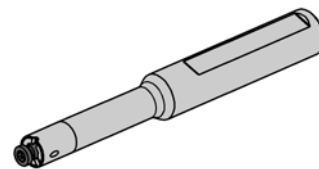
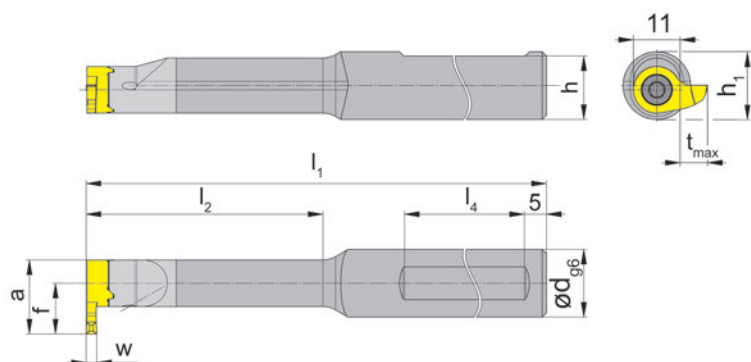
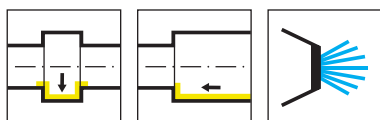

R = version à droite représentée  
R = versione destra come in figura

L = version à gauche  
L = versione sinistra a specchio

Numéro de commande Codice prodotto	d	l <sub>1</sub>	l <sub>2</sub>	h	l <sub>4</sub>	h <sub>1</sub>	HWS
RB18P.0012.00	12	100	25	11	50	12,5	18P110R
RB18P.0012.01	12	120	40	11	50	12,5	18P110R
RB18P.0016.00	16	100	25	15	50	13	18P110R
RB18P.0016.01	16	120	40	15	50	13	18P110R
RB18P.0016.02	16	130	56	15	50	13	18P110R
RB18P.0016.03	16	150	80	15	50	13	18P110R
LB18P.0012.00	12	100	25	11	50	12,5	18P110L
LB18P.0012.01	12	120	40	11	50	12,5	18P110L
LB18P.0016.00	16	100	25	15	50	13	18P110L
LB18P.0016.01	16	120	40	15	50	13	18P110L
LB18P.0016.02	16	130	56	15	50	13	18P110L
LB18P.0016.03	16	150	80	15	50	13	18P110L

w, a, tmax et f voir plaquettes  
w, a, tmax, f vd. Inserti

L

## Pièces Détachées

Ricambi

Porte outils Portainsero	Vis de serrage Vite di serraggio	Tournevis TORX PLUS® Cacciavite TORX PLUS®
R/LB18P...	5.13T20EP	T20PQ

# Plaquette de coupe Inserto

## S18P $\varnothing \geq 18$ mm

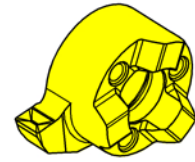
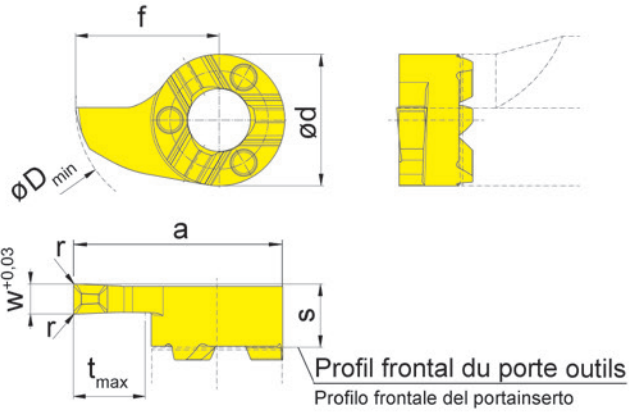
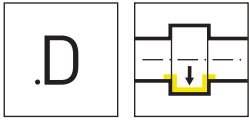

R = version à droite représentée  
R = versione destra come in figura

L = version à gauche  
L = versione sinistra a specchio

▲ en stock  
a stock

Nuance  
Leghe  
Δ 4 semaines  
4 settimane

Numéro de commande Codice prodotto	w	s	f	a	r	d	t <sub>max</sub>	D <sub>min</sub>	HIS	Nuance / Leghe	
										EG55	TH35
RS18P.0200.1.D2	2	5,3	12	17,5	0,2	11	6	18	18P110R	▲	▲
RS18P.0250.1.D2	2,5	5,3	12	17,5	0,2	11	6	18	18P110R	▲	▲
RS18P.0300.1.D2	3	5,3	12	17,5	0,2	11	6	18	18P110R	▲	▲
LS18P.0200.1.D2	2	5,3	12	17,5	0,2	11	6	18	18P110L	▲	▲
LS18P.0250.1.D2	2,5	5,3	12	17,5	0,2	11	6	18	18P110L	▲	▲
LS18P.0300.1.D2	3	5,3	12	17,5	0,2	11	6	18	18P110L	▲	▲
										P	●
										M	○
										K	○
										N	-
										S	-
										H	-



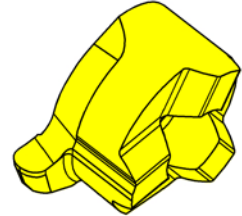
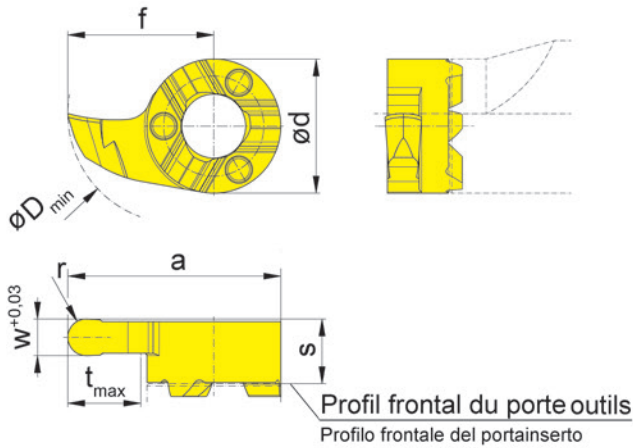
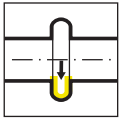

R = version à droite représentée  
R = versione destra come in figura

L = version à gauche  
L = versione sinistra a specchio

▲ en stock  
a stock

Nuance  
Leghe  
Δ 4 semaines  
4 settimane

Numéro de commande Codice prodotto	w	s	f	a	r	d	t <sub>max</sub>	D <sub>min</sub>	HIS	Nuance Leghe	
										EG55	TH35
R18P.0009.1.18	1,8	5,3	12	17,5	0,9	11	6	18	18P110R	▲	▲
R18P.0011.1.22	2,2	5,3	12	17,5	1,1	11	6	18	18P110R	▲	▲
R18P.0015.1.30	3	5,3	12	17,5	1,5	11	6	18	18P110R	▲	▲
L18P.0009.1.18	1,8	5,3	12	17,5	0,9	11	6	18	18P110L	Δ	▲
L18P.0011.1.22	2,2	5,3	12	17,5	1,1	11	6	18	18P110L	Δ	▲
L18P.0015.1.30	3	5,3	12	17,5	1,5	11	6	18	18P110L	Δ	▲
										P	●
										M	○
										K	○
										N	-
										S	-
										H	-

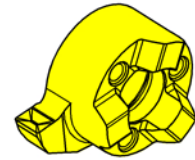
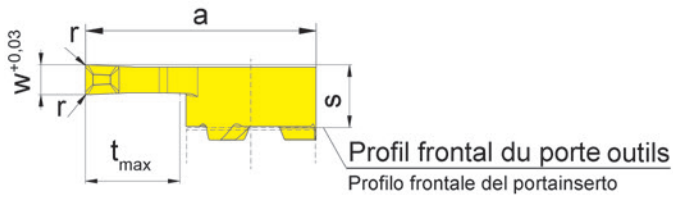
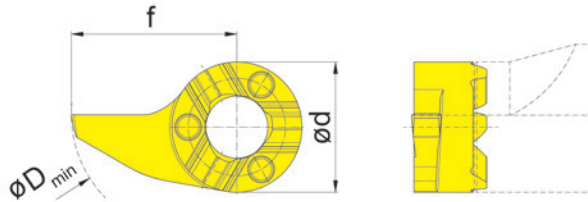
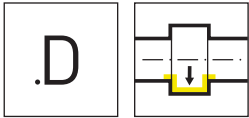

R = version à droite représentée  
R = versione destra come in figura

L = version à gauche  
L = versione sinistra a specchio

▲ en stock  
a stock

Nuance  
Leghe  
Δ 4 semaines  
4 settimane

Numéro de commande Codice prodotto	w	s	f	a	r	d	t <sub>max</sub>	D <sub>min</sub>	HIS	Nuance Leghe	
										EG55	TH35
RS18P.0200.2.D2	2	5,3	14	19,5	0,2	11	8	20	18P110R	▲	▲
RS18P.0250.2.D2	2,5	5,3	14	19,5	0,2	11	8	20	18P110R	▲	▲
RS18P.0300.2.D2	3	5,3	14	19,5	0,2	11	8	20	18P110R	▲	▲
LS18P.0200.2.D2	2	5,3	14	19,5	0,2	11	8	20	18P110L	▲	▲
LS18P.0250.2.D2	2,5	5,3	14	19,5	0,2	11	8	20	18P110L	Δ	▲
LS18P.0300.2.D2	3	5,3	14	19,5	0,2	11	8	20	18P110L	▲	▲
										P	●
										M	○
										K	○
										N	-
										S	-
										H	-

# Plaquette de coupe Inserto

## S18P $\varnothing \geq 17,5$ mm

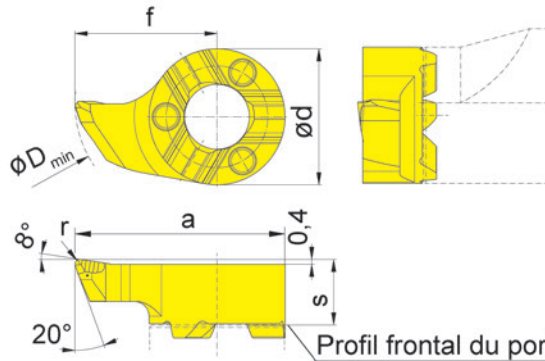
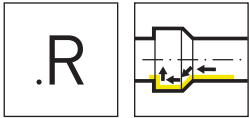

Profil frontal du porte outils  
Profilo frontale del portainsero

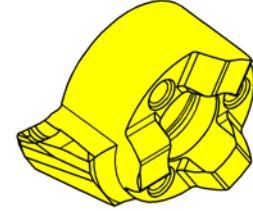

R = version à droite représentée  
R = versione destra come in figura

L = version à gauche  
L = versione sinistra a specchio

▲ en stock  
a stock

Nuance  
Leghe  
Δ 4 semaines  
4 settimane

Numéro de commande Codice prodotto	s	f	a	r	d	D <sub>min</sub>	HIS	Nuance Leghe	
								EG55	TH35
RS18P.1815.R2	5,3	11,5	17	0,2	11	17,5	18P110R	Δ	▲
RS18P.1815.R4	5,3	11,5	17	0,4	11	17,5	18P110R	▲	▲
LS18P.1815.R2	5,3	11,5	17	0,2	11	17,5	18P110L	Δ	Δ
LS18P.1815.R4	5,3	11,5	17	0,4	11	17,5	18P110L	▲	▲
								P	● ●
								M	○ ●
								K	○ ●
								N	- ●
								S	- ●
								H	- -

L

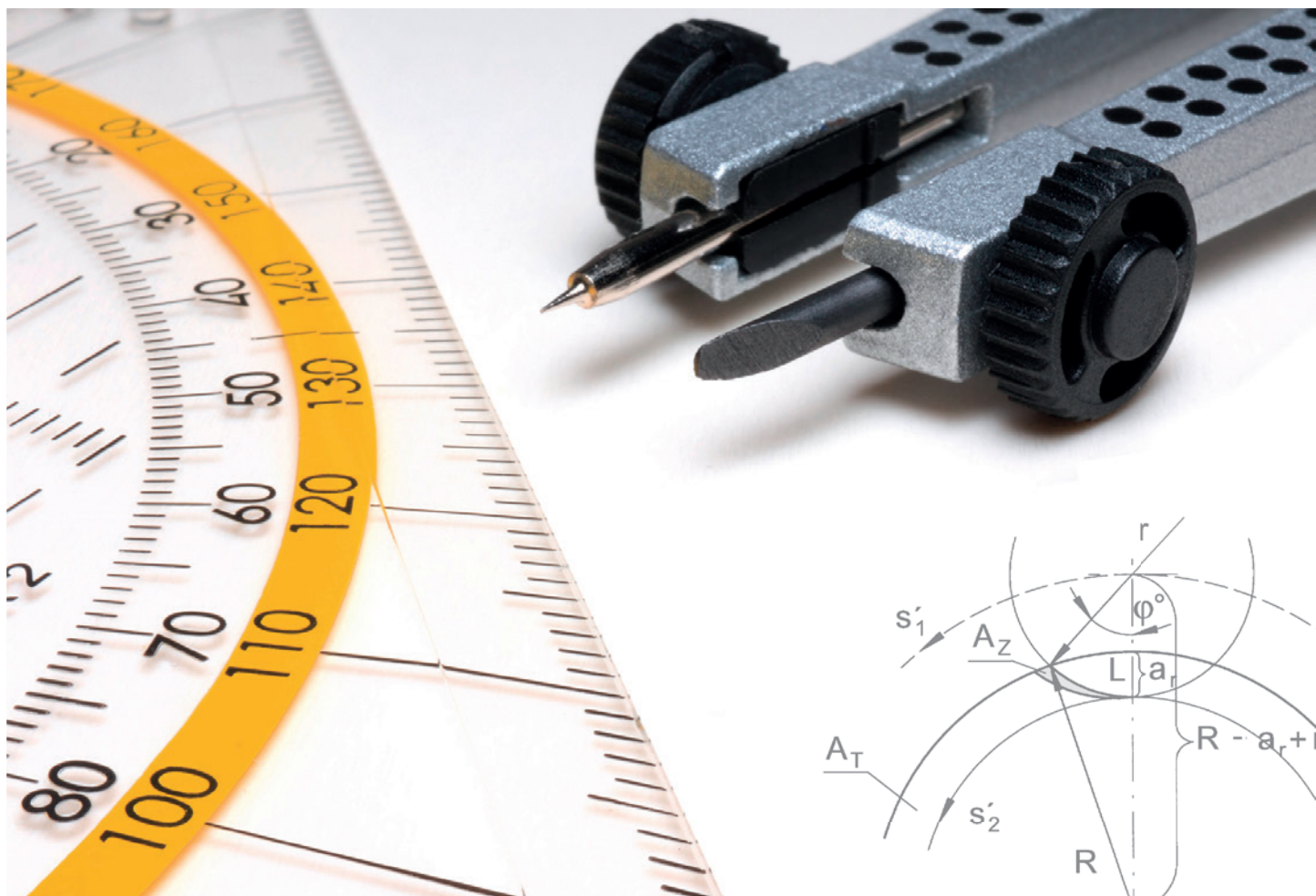

Sommaire/Indice	Page/Pagina
Vue d'ensemble des revêtements Panoramica dei rivestimenti	364-365
Conditions de coupe Parametri di taglio	366-371
Géométries et avance Geometrie e avanzamenti	372-373
Conditions de coupe et géométries R/L105.B0 Parametri di taglio e geometrie R/L105.B0	374-375
Informations techniques Dati tecnici	376-378
Couple de serrage Coppia di serraggio	379
Exemple d'usinage Esempi di lavorazione	380-383
Accessoires Accessori	384-389

# Vue d'ensemble des revêtements

## Panoramica dei rivestimenti



Matériau de coupe Gruppo di materiali	Structure du revêtement Rivestimento	Recommandation Raccomandazioni di utilizzo						Application Applicazione
		P05	M05	K05	N05	S05	H05	
TH3_	TiAlN	P10	M10	K10	N10	S10	H10	<p>Pour des avances moyennes, convient également en cas de coupe interrompues</p> <p>Per avanzamenti medi, adatto anche per tagli interrotti</p>
		P20	M20	K20	N20	S20	H20	
		P30	M30	K30	N30	S30	H30	
		P40	M40	K40	N40			
		P50	M50					
EG3_	AlTiN + TiN	P05	M05	K05	N05	S05	H05	<p>Pour des avances faibles à moyennes, pour la finition sans interruption de la coupe</p> <p>Per avanzamenti medio-bassi, per una finitura senza interruzioni del taglio</p>
		P10	M10	K10	N10	S10	H10	
		P20	M20	K20	N20	S20	H20	
		P30	M30	K30	N30	S30	H30	
		P40	M40	K40	N40			
		P50	M50					
EG5_	AlTiN + TiN	P05	M05	K05	N05	S05	H05	<p>Pour des avances moyennes, convient également en cas de coupe interrompues</p> <p>Per avanzamenti medi, adatto anche per tagli interrotti</p>
		P10	M10	K10	N10	S10	H10	
		P20	M20	K20	N20	S20	H20	
		P30	M30	K30	N30	S30	H30	
		P40	M40	K40	N40			
		P50	M50					
ES1_	AlTiN	P05	M05	K05	N05	S05	H05	<p>Pour la super finition avec des petites avances, pour la finition sans interruption de la coupe</p> <p>Per la superfinitura e per gli avanzamenti ridotti, per la finitura senza interruzione di taglio</p>
		P10	M10	K10	N10	S10	H10	
		P20	M20	K20	N20	S20	H20	
		P30	M30	K30	N30	S30	H30	
		P40	M40	K40	N40			
		P50	M50					
IG3_	TiAlSiN	P05	M05	K05	N05	S05	H05	<p>Pour des vitesses de coupe élevées sans aucune interruption de la coupe</p> <p>Per velocità di taglio elevate, senza interruzione di taglio</p>
		P10	M10	K10	N10	S10	H10	
		P20	M20	K20	N20	S20	H20	
		P30	M30	K30	N30	S30	H30	
		P40	M40	K40	N40			
		P50	M50					

# Vue d'ensemble des revêtements

## Panoramica dei rivestimenti



Matériau de coupe Gruppo di materiali	Structure du revêtement Rivestimento	Recommandation Raccomandazioni di utilizzo						Application Applicazione
SG3_	TiAlCrSiN	P05	<b>M05</b>	K05	N05	<b>S05</b>	H05	Pour des avances faibles à moyennes, pour la finition sans interruption de la coupe  Per avanzamenti medio-bassi, per una finitura senza interruzioni del taglio
		P10	<b>M10</b>	K10	N10	<b>S10</b>	H10	
		P20	M20	K20	N20	<b>S20</b>	<b>H20</b>	
		P30	M30	K30	N30	S30	H30	
		P40	M40	K40	N40			
		P50	M50					
TI2_	TiCN	P05	M05	K05	N05	S05	H05	Pour des avances faibles à moyennes à des de faibles vitesses de coupe, réduction des arêtes rapportées  Per avanzamenti da piccoli a medi a basse velocità di taglio, riduce gli incollamenti
		P10	M10	K10	N10	S10	H10	
		P20	M20	K20	N20	S20	H20	
		P30	M30	K30	N30	S30	H30	
		<b>P40</b>	<b>M40</b>	K40	N40			
		<b>P50</b>	M50					
TN3_	TiN	P05	M05	K05	N05	S05	H05	Pour les faibles vitesses de coupe, adapté à la coupe interrompues  Per basse velocità di taglio, adatto per interruzioni di taglio
		P10	M10	K10	N10	S10	H10	
		P20	M20	K20	N20	S20	H20	
		P30	M30	K30	N30	S30	H30	
		<b>P40</b>	M40	<b>K40</b>	N40			
		<b>P50</b>	M50					

ISO 513		P	M	K	N	S	H
+ Ténacité / Tenacità	- Résistance à l'usure / Resistenza all'usura +	05	05	05	05	05	05
		10	10	10	10	10	10
		20	20	20	20	20	20
		30	30	30	30	30	30
		40	40	40	40		
		50	50				

# Conditions de coupe

## Parametri di taglio



Matière Materiale		Groupe de matières Gruppo materiale	Dureté Brinell Durezza Brinell (HB)	Ténacité R <sub>m</sub> [N/mm <sup>2</sup> ] Tenacità	Exemple de matériau Esempio di materiale	
<b>P</b>	Acier non allié Acciaio non legato	~ 0,2 % C	P1.1	125	430	CK15
		~ 0,4% C recuit ricotti	P1.2	190	610	19Mn6
		~ 0,4% C traités bonificati	P1.3	210	640	36Mn5
		~ 0,6% C recuit ricotti	P1.4	190	610	C55
		~ 0,6% C traités bonificati	P1.5	300	1000	CK60
		Acier de décolletage Acciaio da taglio gratuito	P1.6	220	750	9SMn28
	Acier faiblement allié (<5%) Acciai basso legati	recuit ricotti	P2.1	180	590	100Cr6
		traités bonificati	P2.2	280	960	14NiCr10
		traités bonificati	P2.3	350	1250	34CrMo4
		traités bonificati	P2.4	430	1450	55Cr3
	Acier hautement allié (>5%) Acciai alto legati	recuit ricotti	P3.1	200	680	X10CrAl18
		gehärtet hardened	P3.2	350	1200	X210Cr2
	Acier moulé Acciaio fuso	non allié non legato	P4.1	180	590	GE200
		allié legato	P4.2	220	750	GX40CrSi28
	Acier fritté Acciaio sinterizzato	doux morbido	P5.1	220	570	Sint-D39
<b>M</b>	Acier inoxydable Acciaio inossidabili	martensitique ferritique martensitici ferritici	M1.1	200	680	X16Cr13
		austenitique austenitici	M1.2	300	1000	X6CrNiMo- Ti17-12-2
		austenitique ferritique austenitici ferritici	M1.3	230	780	X2CrNiMo- N17-13-3

# Conditions de coupe

## Parametri di taglio



	Vitesse de coupe vc (m/min) / Valeurs de départ Velocità di taglio vc (m/min) / Valori di partenza								
	MG12	TN3_	TI2_	TH3_ TF4_	AN2_ RC2_	EG3_ EG5_	IG3_	DD2_	SG3_
	120-16	180 - 16	180 - 16	210 - 16	210 - 16	200 - 16	230-16		230-16
	110-16	170-16	170-16	200-16	200-16	200-16	230-16		230-16
	110-16	160-16	160-16	190-16	190-16	190-16	220-16		220-16
	110-16	150-16	150-16	180-16	180-16	180-16	210-16		210-16
	100-16	120-16	140-16	170-16	170-16	170-16	200-16		200-16
	120-16	160-16	160-16	190-16	190-16	190-16	220-16		220-16
	90 - 16	150 - 16	150 - 16	180-16	180-16	180 - 16	210-16		210-160
	85-16	140-16	140-16	180-16	180-16	180 - 16	210-160		210-160
	80-16	140-16	140-16	180-16	180-16	180 - 16	210-16		210-16
	80-16	140-16	140-16	160-16	160-16	160-16	180-16		180-16
	90-16	90 - 16	90 - 16	140 - 16	140 - 16	120 - 16	140-16		140-16
									140-16
	110-16	180 - 16	180 - 16	180 - 16	180 - 16	160 - 16	180-16		180-16
	70-16	170-16		180 - 16	180 - 16	160 - 16	180-16		180-16
		90 - 16		90 - 19	90 - 16	90 - 16	100 - 15		100 - 16
		80 - 16		80 - 16	80 - 16	80 - 16	80 - 16		40 - 16
		60-16		60-16	60-16	60-16	70-16		80-16

# Conditions de coupe

## Parametri di taglio



Matière Materiale		Groupe de matières Gruppo materiale	Dureté Brinell Durezza Brinell (HB)	Ténacité R <sub>m</sub> [N/mm <sup>2</sup> ] Tenacità	Exemple de matériau Esempio di materiale	
<b>K</b>	Fonte grise Ghise	basse ténacité alta tenacità	K1.1	180	250	GG-25
		haute ténacité bassa tenacità	K1.2	250	350	GG-40
	Fonte graph. sphéroïdale Ghise sferoidali	ferritique ferritici	K2.1	160	400	GGG-40
		perlitique perlitici	K2.2	260	700	GGG-60
	Fonte malléable Ghisa malleabile	ferritique ferritic	K3.1	200	400	GTW-45
		perlitique perlitici	K3.2	260	700	GTS-55-04
	Fonte ausferritique/ADI Ausferritico Ghisa/ ADI	traités bonificati	K4.1	260	800	
		traités bonificati	K4.2	350	1050	
		traités bonificati	K4.3	450	1400	
<b>N</b>	Alliage d'aluminium Leghe d'alluminio	nicht vergütbar not heat treatable	N1.1	30		AlMg1
		vergütbar heat treatable	N1.2	100	340	AlMgSi1
	Alliage de fonte d'aluminium Leghe di alluminio presso fuso	< 6% Si	N2.1	80	300	AlMgSi6
		6-10% Si	N2.2	100	320	AlSi7Mg
		10-15 % Si	N2.3	130	450	AlSi12
	Alliages de cuivre Leghe di rame	Reinkupfer Pure copper	N3.1	100	340	Cu
		Messing, Bronze Brass	N3.2	90	310	CuZn40Pb
		Messing bleifrei Lead-free brass	N3.3	110	430	CuZn40
		hochfest high strength	N3.4	300	1000	CuZn25Al5- Mn4Fe3
	Graphite Grafite		N4.1			

# Conditions de coupe

## Parametri di taglio



	Vitesse de coupe vc (m/min) / Valeurs de départ Velocità di taglio vc (m/min) / Valori di partenza								
	MG12	TN3_	TI2_	TH3_ TF4_	AN2_ RC2_	EG3_ EG5_	IG3_	DD2_	SG3_
	90 - 16	150 - 16		160 - 16		160 - 16			
		120 - 16							
	90 - 16	130 - 16							
		100-16		160 - 18		140 - 16			
		130 - 16		180 - 16		160 - 18			
	220 - 16		220 - 16	220 - 16		220 - 16		350 - 16	
	220 - 16		220 - 16	220 - 16		220 - 16		350 - 16	
	220 - 16		220 - 16	220 - 16		220 - 16		350 - 16	
								350-16	
	220 - 16							300 - 16	
	220 - 16							300 - 16	
	220 - 16							250 - 16	
	180 - 16							200 - 16	

Matière Materiale		Groupe de matières Gruppo materiale	Dureté Brinell Durezza Brinell (HB)	Ténacité $R_m$ [N/mm <sup>2</sup> ] Tenacità	Exemple de matériau Esempio di materiale	
<b>S</b>	Résistant à la chaleur Alliage (Fe) Leghe resistenti al calore	recuit ricotti	S1.1	200	670	
		trempe temprato	S1.2	275	930	
	Résistant à la chaleur Alliage (Ni, Co) Leghe resistenti al calore	recuit ricotti	S2.1	250	840	Inconel 600
		trempe temprato	S2.2	350	1200	Inconel 713
	Titane Titanio	Alliage de titane $\alpha$ Lega di titanio $\alpha$	S3.1	120	240	Ti99,7
		Alliage de titane $\alpha$ - $\beta$ Lega di titanio $\alpha$ - $\beta$	S3.2	360	1200	Ti6Al4V
		Alliage de titane $\beta$ Lega di titanio $\beta$	S3.3	410	1400	Ti-10V-2Fe-3Al
	<b>H</b>	Aciers trempés Acciai temprat	50-55 HRC	H1.1	-	-
			55-60 HRC	H1.2	-	-
60-63 HRC			H1.3	-	-	
> 63HRC			H1.4	-	-	
<b>O</b>	Thermoplastiques Termoplastiche		O1.1			
	Plastique dur Plastica dura		O1.2			
	Plastiques renforcés de fibres de verre Plastiche caricate a fibra di vetro	GFK	O1.3			
	Plastiques renforcés de fibres de carbone Plastiche caricate a fibra di carbonio	CFK	O1.4			

# Conditions de coupe

Parametri di taglio



	Vitesse de coupe vc (m/min) / Valeurs de départ Velocità di taglio vc (m/min) / Valori di partenza								
	MG12	TN3_	TI2_	TH3_ TF4_	AN2_ RC2_	EG3_ EG5_	IG3_	DD2_	SG3_
	50-16						75-16		75 -16
	50-16								
	30-16						40 - 16		40 - 16
	30-16						40 - 16		40 - 16
	30-16						75 - 16		85-16
	30-16						75 -16		85-16
	30-16						75-16		85-16
							50 - 16		60 - 16
							50 - 16		60 - 16
	150 - 16								
	150 - 16								
	150 - 16								
	300 - 16								

# Géométries et avances - Supermini

Geometrie e avanzamenti - Supermini



Géométrie Geometria	Matière Materiale	Avance f [mm/rot.] Avanzamento f [mm/rev]	Usinage Lavorazione						
	<table border="1"> <tr> <td>P</td> <td>M</td> <td>K</td> </tr> <tr> <td>N</td> <td>S</td> <td>H</td> </tr> </table>	P	M	K	N	S	H	<p>←</p> <p>f = 0,04-0,06 ap = 0,15-0,5 mm</p>	
P	M	K							
N	S	H							
	<table border="1"> <tr> <td>P</td> <td>M</td> <td>K</td> </tr> <tr> <td>N</td> <td>S</td> <td>H</td> </tr> </table>	P	M	K	N	S	H	<p>←</p> <p>f = 0,05-0,1 ap = 0,15-0,5 mm</p>	
P	M	K							
N	S	H							
	<table border="1"> <tr> <td>P</td> <td>M</td> <td>K</td> </tr> <tr> <td>N</td> <td>S</td> <td>H</td> </tr> </table>	P	M	K	N	S	H	<p>↓</p> <p>↔</p> <p>f = 0,01-0,04 ap = 0,03-0,05 mm</p>	
P	M	K							
N	S	H							
	<table border="1"> <tr> <td>P</td> <td>M</td> <td>K</td> </tr> <tr> <td>N</td> <td>S</td> <td>H</td> </tr> </table>	P	M	K	N	S	H	<p>←</p> <p>f = 0,003-0,04 ap = 0,005-0,1 mm</p>	
P	M	K							
N	S	H							
	<table border="1"> <tr> <td>P</td> <td>M</td> <td>K</td> </tr> <tr> <td>N</td> <td>S</td> <td>H</td> </tr> </table>	P	M	K	N	S	H	<p>←</p> <p>f = 0,03-0,07 ap = 0,1-0,4 mm</p>	
P	M	K							
N	S	H							

Avance f [mm/rot.]

Avanzamento f [mm/rev]

f = 0,01-0,03

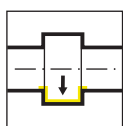

Gorge  
Gole

f = 0,02-0,05

ap = 0,15-0,5 mm

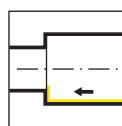

Chariotage  
Tornitura in passata

f = 0,02-0,05

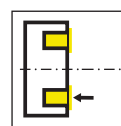

Gorge frontale  
Gole assiali

# Géométries et avances - Mini

Geometrie e avanzamenti - Mini



Géométrie Geometria	Matière Materiale	Avance f [mm/rot.] Avanzamento f [mm/rev]	Usinage Lavorazione						
	<table border="1"> <tr> <td>P</td> <td>M</td> <td>K</td> </tr> <tr> <td>N</td> <td>S</td> <td>H</td> </tr> </table>	P	M	K	N	S	H	<p>↓ f = 0,03-0,08</p> <p>↔ ap = 0,2-1,5*</p>	
P	M	K							
N	S	H							
	<table border="1"> <tr> <td>P</td> <td>M</td> <td>K</td> </tr> <tr> <td>N</td> <td>S</td> <td>H</td> </tr> </table>	P	M	K	N	S	H	<p>↓ f = 0,015-0,05</p> <p>↔ ap = 0,03-0,07*</p>	
P	M	K							
N	S	H							
	<table border="1"> <tr> <td>P</td> <td>M</td> <td>K</td> </tr> <tr> <td>N</td> <td>S</td> <td>H</td> </tr> </table>	P	M	K	N	S	H	<p>← f = 0,05-0,15</p> <p>ap = 0,05-0,6</p>	
P	M	K							
N	S	H							
	<table border="1"> <tr> <td>P</td> <td>M</td> <td>K</td> </tr> <tr> <td>N</td> <td>S</td> <td>H</td> </tr> </table>	P	M	K	N	S	H	<p>← f = 0,05-0,15</p> <p>ap = 0,2-2,0*</p>	
P	M	K							
N	S	H							

\*En fonction du système / Dipendente dal sistema

Avance f [mm/rot.]

Avanzamento f [mm/rev]

f = 0,01-0,05

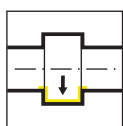

Gorge  
Gole

f = 0,03-0,1

ap = 0,1-0,5 mm

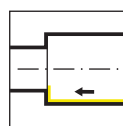

Chariotage  
Tornitura in passata

f = 0,02-0,08

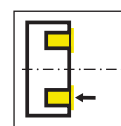

Gorge frontale  
Gole assiali

# Conditions de coupe R/L105.B0...

Parametri di taglio R/L105.B0...



Tournage Acier Alesatura Acciaio		Profondeur de coupe ap (mm) Profondità di taglio ap (mm)					
		0,5	1	1,5	2	2,5	3
		Avances f (mm/trs) Avanzamento f (mm/giro)					
R/L105.B0.30.20.045.1	1,5*D	0,03-0,05	0,02-0,03				
R/L105.B0.30.20.075.1	2,5*D	0,03-0,05	0,02-0,03				
R/L105.B0.40.20.060.1	1,5*D	0,04-0,06	0,04-0,06	0,04-0,06			
R/L105.B0.40.20.100.1	2,5*D	0,04-0,06	0,04-0,06	0,04-0,06			
R/L105.B0.50.20.075.1	1,5*D	0,05-0,08	0,05-0,08	0,04-0,07	0,04-0,07		
R/L105.B0.50.20.125.1	2,5*D	0,05-0,08	0,05-0,08	0,04-0,07	0,04-0,07		
R/L105.B0.60.20.090.1	1,5*D	0,07-0,1	0,07-0,1	0,07-0,1	0,07-0,1	0,05-0,08	
R/L105.B0.60.20.150.1	2,5*D	0,07-0,1	0,07-0,1	0,07-0,1	0,07-0,1	0,05-0,08	
R/L105.B0.70.20.105.1	1,5*D	0,08-0,1	0,07-0,1	0,07-0,1	0,07-0,1	0,07-0,08	0,05-0,07
R/L105.B0.70.20.175.1	2,5*D	0,08-0,1	0,07-0,1	0,07-0,1	0,07-0,1	0,07-0,08	0,05-0,07

Avance pour les matériaux inoxydables: Sélectionnez les valeurs minimales

In caso di lavorazione di materiali inossidabili, selezionare i valori di riferimento più bassi

Perçage Acier Foratura Acciaio		Avances f (mm/trs) Avanzamento f (mm/giro)
R/L105.B0.30.20.045.2	1,5*D	0,01-0,02
R/L105.B0.30.20.075.2	2,5*D	0,01-0,02
R/L105.B0.40.20.060.2	1,5*D	0,01-0,02
R/L105.B0.40.20.100.2	2,5*D	0,01-0,02
R/L105.B0.50.20.075.2	1,5*D	0,02-0,04
R/L105.B0.50.20.125.2	2,5*D	0,02-0,04
R/L105.B0.60.20.090.2	1,5*D	0,03-0,05
R/L105.B0.60.20.150.2	2,5*D	0,03-0,05
R/L105.B0.70.20.105.2	1,5*D	0,03-0,05
R/L105.B0.70.20.175.2	2,5*D	0,03-0,05

Pour le perçage, nous recommandons la géométrie universelle

In foratura raccomandiamo la geometria universale

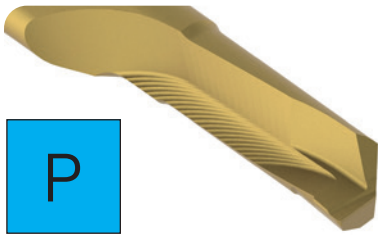

R/L105.B0...1

### Géométrie avec brise-copeaux pour un meilleur contrôle des copeaux

- Tournage à grandes avances
- Pour les aciers en général
- une nouvelle arête de coupe pour des avances plus élevées
- Meilleur contrôle des copeaux
- Perçage pour des aciers en général
- Pour des applications problématiques dans le but de sécuriser le processus
- Egalement pour les matériaux à copeaux longs

### Geometria rompitruciolo per miglior controllo truciolo

- Tornitura con forti asportazioni
- Per acciai
- Tagliente che supporta fortissimi avanzamenti
- Miglior controllo del truciolo
- Foratura su acciai convenzionali
- Per l'affinamento dei tempi ciclo
- Adatto anche su materiali a truciolo lungo



R/L105.B0...2

### Géométrie universelle

- Tournage à grandes avances
- Géométrie universelle, même pour les aciers inoxydables
- Une nouvelle arête de coupe pour des avances plus élevées.
- Moins de pression de coupe et convient même pour les pièces à paroi mince
- Pour le perçage d'acier et des matériaux non ferreux

### Geometria Universale

- Tornitura con forti asportazioni
- Geometria universale adatta anche su inossidabili
- Bassa pressione di taglio, idonea anche su cartelle sottili
- Foratura su acciai e leghe non ferrose

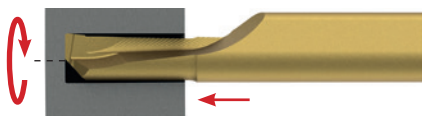

Perçage en pleine matière et permet d'obtenir un fond plat

Foratura dal pieno generando un fondo piatto

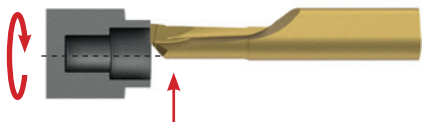

Dressage de face en tournage

Sfacciatura

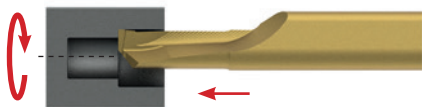

Chariotage de profils inter

Tornitura di profili interni

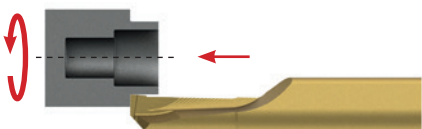

Tournage de profils exter

Tornitura di profili esterni

### Filetage

Tous les filetages avec angle d'hélice jusqu'à 4,5° peuvent être réalisés avec les plaquettes à fileter standard HORN. Aucun rattrapage d'angle n'est nécessaire.

### Logements

Le logement des outils Mini, de la même manière que pour les Supermini®; garantit la mise au centre de la hauteur de pointe de la plaquette. En dépit de ça, il convient de toujours vérifier les outils car une variation de hauteur peut engend.

### Evacuation copeaux

Choisir une plaquette de petite largeur, ainsi, en cas de problème d'évacuation, le copeau s'évacue de l'alésage le long de l'outil. Pour éviter le bourrage copeau, utiliser la technique de gorges par étapes.

### Arrosage

Utiliser de l'émulsion pour évacuer les copeaux et refroidir la plaquette. Une pression d'arrosage de 10 bar mini. est recommandée.

### La filettatura

Gli inserti HORN del Programma Supermini® e Mini possono eseguire filettature con angolo d'elica fino a 4,5°. Inoltre non sono richieste placchette d'appoggio.

### Posizionamento dell'inserto

L'alloggiamento degli inserti sui relativi portainseriti dei programmi Supermini® e Mini garantisce l'accurata altezza del tagliente. E' comunque sempre buona norma di prudenza verificare in macchina tale altezza, in quanto anche una minima differenza può provocare problemi, soprattutto nei piccoli diametri.

### Evacuazione del truciolo

Consigliamo di usare inserti con piccola larghezza del tagliente, al fine di facilitare l'evacuazione del truciolo. Per evitare l'ammasso del truciolo nella gola consigliamo di effettuare eventuali soste nella lavorazione.

### Refrigerante

Consigliamo di filtrare il refrigerante per una migliore evacuazione del truciolo. Consigliamo una pressione del refrigerante di almeno 10 bar.

$V_{max}$ m/min	Acier (Nmm <sup>2</sup> Ténacité) Acciaio (N/mm <sup>2</sup> Tenacità)					Acier inoxidable Acciai inossidabili	Fonte grise Ghise	Aluminium Alluminio
	400-500	500-700	700-850	850-1150	> 1150	90	100	300
	160	140	120	90	70	90	100	300

Pas Passo	mm	fil/pouce fil./pollici	Nombre de passes Numero di passate							
			Acier (Nmm <sup>2</sup> Ténacité) Acciaio (N/mm <sup>2</sup> Tenacità)					Acier inoxidable Acciai inossidabili	Fonte grise Ghise	Aluminium Alluminio
			400-500	500-700	700-850	850-1150	> 1150			
0,8	32		10	10	12	12	14	14	12	10
1,0	24		13	13	15	15	18	18	15	13
1,25	20-19		16	16	19	19	22	22	19	16
1,5	16		20	20	23	23	27	27	23	20
1,75	14		23	23	27	27	31	31	27	23
2,0	12-11		27	27	30	30	36	36	30	27
2,5	10		33	33	38	38	45	45	38	33
3,0-3,5	8		40	40	46	46	54	54	46	40

Le nombre de passes recommandées dans le tableau ci-dessus, sont des chiffres à titre indicatif.

### Notez SVP:

- Pour éviter les ruptures plaquettes, la profondeur de coupe pour la 1er passe doit être faible
- Les passes de finition (avec une profondeur de coupe nulle) ne sont pas considérés dans le tableau

Nella tabella soprastante è indicato il numero di passate raccomandate in maniera approssimativa.

### Notare Bene:

- Per evitare rotture del tagliente, la profondità della prima passata non deve essere troppo elevata
- Passate di finitura (con profondità di taglio uguale a zero) non sono considerate nella tabella.

## Avances filetage intérieur

Direzione d'avanzamento filettatura interna

Filetage à droite  
Filettatura destra

Filetage à gauche  
Filettatura sinistra

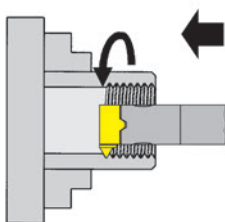

Plaquette à droite  
Inserto destro

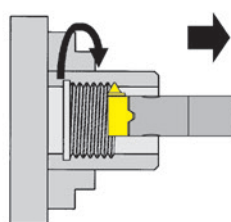

Plaquette à gauche  
Inserto sinistro

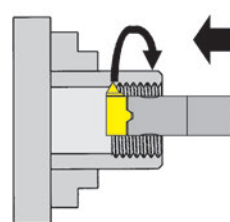

Plaquette à gauche  
Inserto sinistro

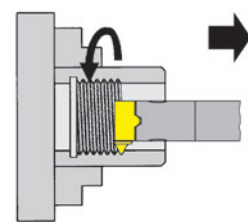

Plaquette à droite  
Inserto destro

### Penetration

#### Penetrazione

##### Penetration radiale

Profondeur de pénétration identique par flanc. Méthode de filetage la plus courante.

##### Penetrazione radiale

Sovrametallo uguale sui due fianchi del tagliente. E' il metodo più diffuso nella filettatura di produzione.



##### Penetration degressive sur un flanc

Effort de coupe amoindri et meilleur état de surface sur le flanc correspondant.

##### Penetrazione modificata lungo un fianco

Minor usura sul tagliente che conduce e miglior finitura sul fianco corrispondente.



##### Penetration alternative

Utilisation alternative des arrêtes de coupe prolongeant la durée de vie de plaquette.

##### Penetrazione alternata lungo i fianchi

Entrambi i taglienti vengono utilizzati per l'asportazione, il che significa maggior vita utensile.



##### Penetration parallele au flanc

Meilleure fragmentation et meilleure évacuation du copeau.

##### Avanzamento lungo un fianco

Formazione facilitata del truciolo e miglior dispersione del calore.



# Couple de serrage

## Coppia di serraggio



Les couples de serrage suivants sont autorisés pour les vis des plaquettes. Nous recommandons de ne pas utiliser de moyens de graisse supplémentaires (tels que la graisse au cuivre) pour les vis.

Le seguenti coppie di serraggio sono consentite per le viti degli inserti. Si raccomanda di non utilizzare grassi aggiuntivi (come la pasta di rame) per le viti.

Type Tipo	Vis Vite	$M_d$ Nm	Clé de serrage Chiave	Lame Lama
001	8.075.1835	<b>5</b>	SW4DIN911	DSW40K
AIH	030.3509.T15P	<b>2,5</b>	T10PL	DT10PK
	6.075T15P	<b>5</b>	T15PQ	DT15PK
B10P	2.6.5T8EP	<b>1,2</b>	T8PL	DT8PK
B11P	3.10T9P	<b>1,8</b>	T9PL	DT9PK
B18P	5.13T20EP	<b>6</b>	T20PQ	DT20PK / DT20PQ
B105	6.075T15P	<b>5</b>	T15PQ	DT15PK
B105.00...A...	030.00M8.1188	<b>4</b>	T25PQ	DT25PK / DT25PQ
B105.00...S...	030.0000.1157	<b>2</b>	T15PL	DT15PK
B106	1.8.4T6EP	<b>0,9</b>	T6PL	DT6PK
B107	2.2.5T7EP	<b>1,1</b>	T7PL	DT7PK
B108	2.6.5T8EP	<b>1,2</b>	T8PL	DT8PK
B109	6.075T15P	<b>5</b>	T15PQ	DT15PK
B110	6.075T15P	<b>5</b>	T15PQ	DT15PK
B111	3.512T10EP	<b>3</b>	T10PL	DT10PK
B114	4.12T15EP	<b>5</b>	T15PQ	DT15PK
B116	5.13T20EP	<b>6,5</b>	T20PQ	DT20PK / DT20PQ
BA114	4.12.T15P	<b>5</b>	T15PQ	DT15PK
BKT	6.075T15P	<b>5</b>	T15PQ	DT15PK
BKT105...S...	030.0000.1157	<b>2</b>	T15PL	DT15PK
BU105	6.075T15P	<b>5</b>	T15PQ	DT15PK
BU105.00...S...	030.0000.1157	<b>2</b>	T15PL	DT15PK
H105	6.075T15P	<b>5</b>	T15PQ	DT15PK
HC105	6.075T15P	<b>5</b>	T15PQ	DT15PK
HC114	4.12T15EP	<b>5</b>	T15PQ	DT15PK
HSKT	6.075T15P	<b>5</b>	T15PQ	DT15PK
IR105	6.075T15P	<b>5</b>	T15PQ	DT15PK
KC760	5.12.T20P	<b>6</b>	T15PQ	DT15PK
N	6.075T15P	<b>5</b>	T15PQ	DT15PK
VDI	6.075T15P	<b>5</b>	T15PQ	DT15PK
WFB...105	6.075T15P	<b>5</b>	T15PQ	DT15PK
WFB...110	6.075T15P	<b>5</b>	T15PQ	DT15PK
WFB...114	4.12T15EP	<b>5</b>	T15PQ	DT15PK

### Plaquette type 105

Ebavurage d'un trou débouchant avec plaquette à rayon complet rotative

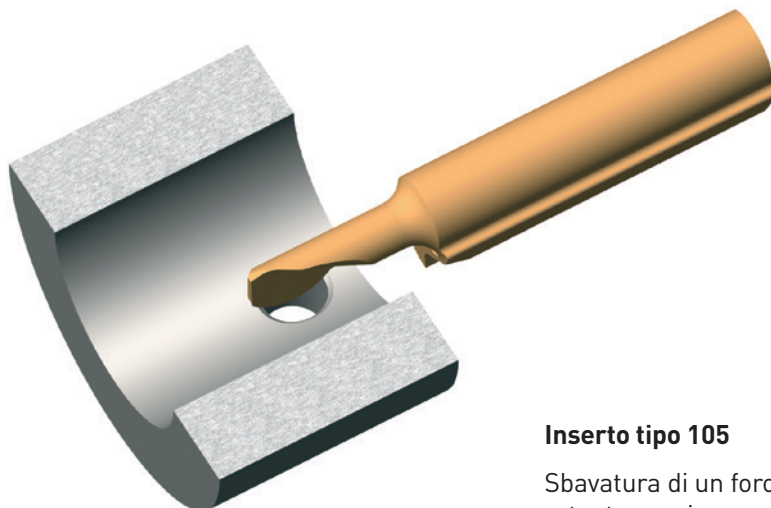

### Inserto tipo 105

Sbavatura di un foro passante con inserto rotante raggio completo

### Plaquette type 105

Profil dans une gorge frontale (plaquette à rayon complet)

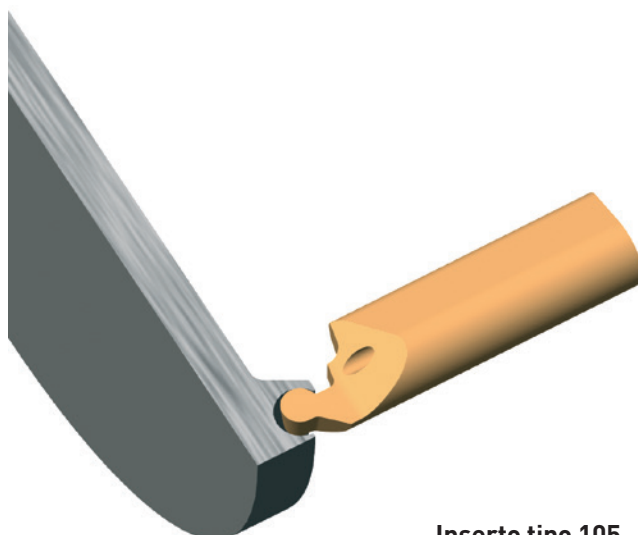

### Inserto tipo 105

Profilatura e gola frontale (inserto raggio completo)

### Plaquette type 105

Usinage d'un chanfrein en fond d'alésage

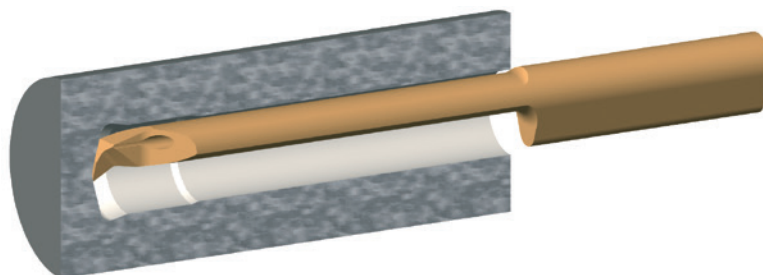

### Inserto tipo 105

Lavorazione di un sottosquadra in un foro a fondo piatto

### Plaquette type 105

Usinage d'une queue d'arronde

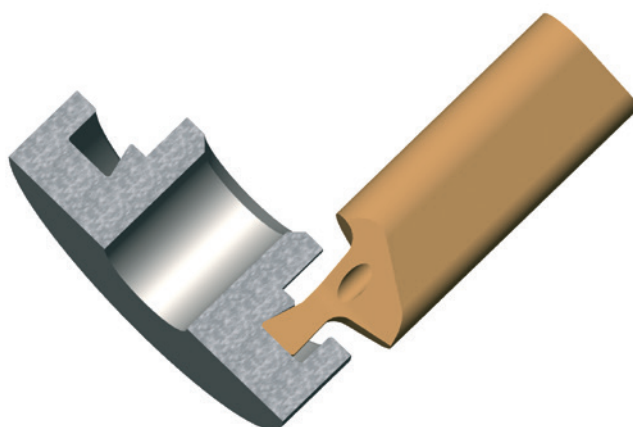

### Inserto tipo 105

Lavorazione di una gola assiale a "coda di rondine"

### Plaquette type 108

Gorge de dégagement avec angle spécial

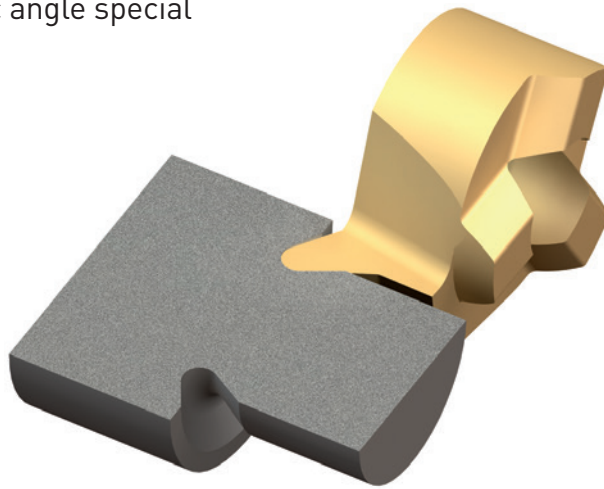

#### Inserto tipo 108

Inserto speciale per gola in sottosquadra

### Plaquette type 111

Profil réaliser, gorge intérieur avec usinage des faces

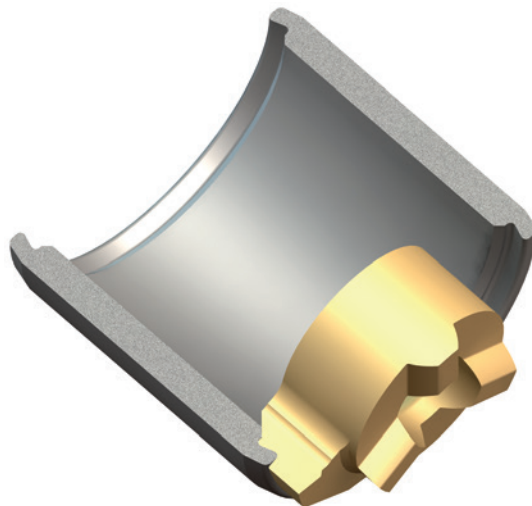

#### Inserto tipo 111

Inserto speciale gola di forma e sfacciatura

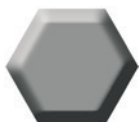

Brochage "Hexagone intérieur"  
Stozzatura "Sedi Esagone"

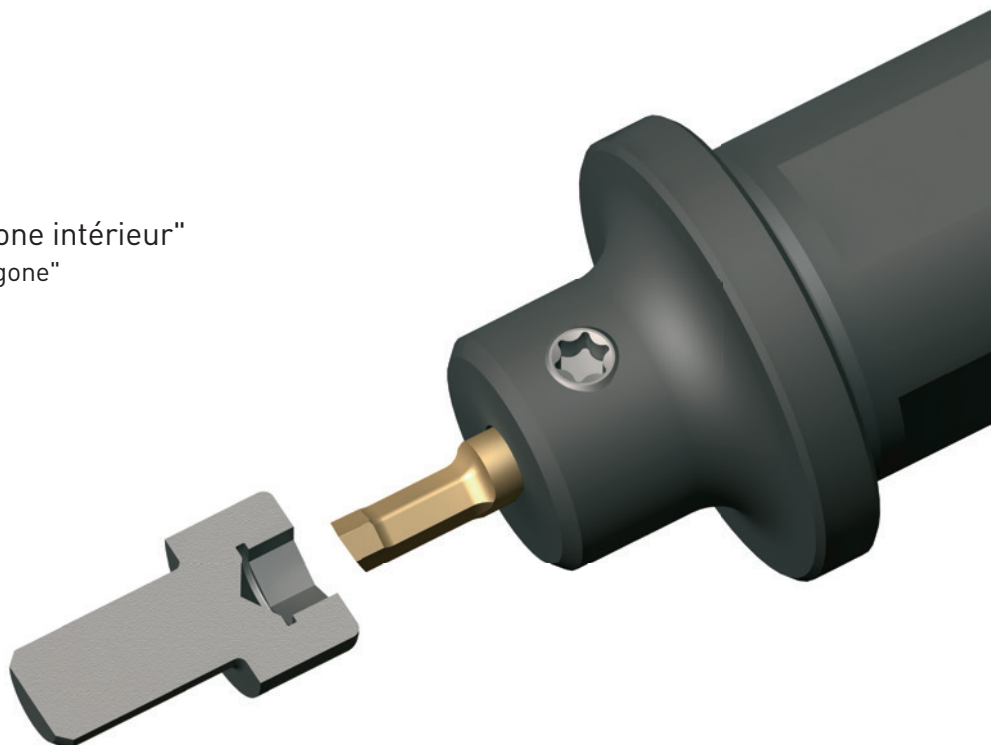

Brochage "Torx"  
Stozzatura "Torx"

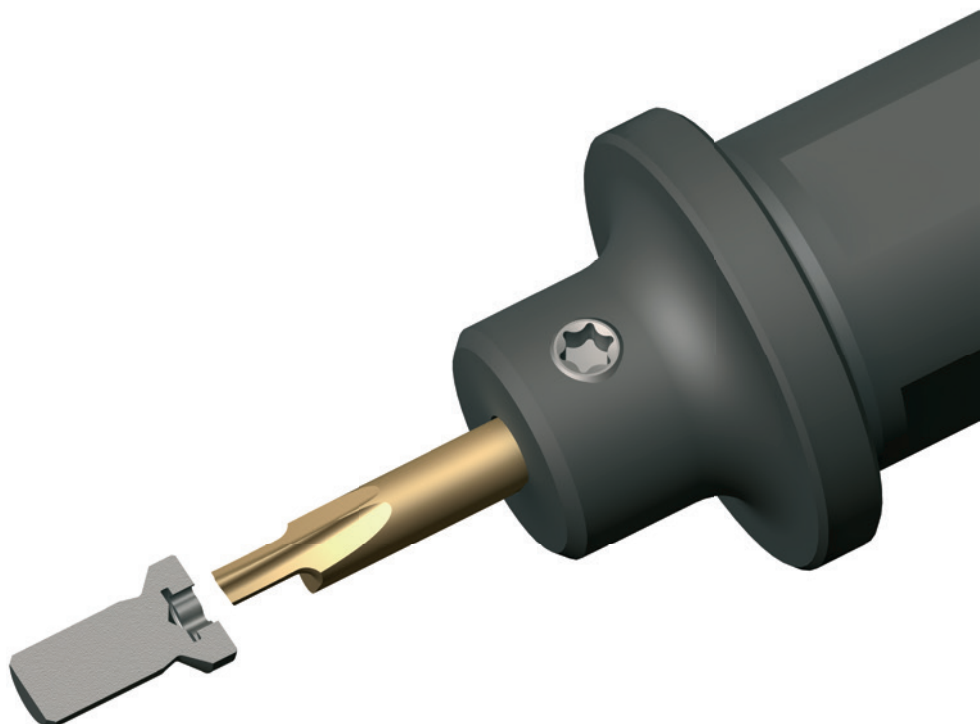

Pour plus d'informations, contactez HORN catalogue „GORGES ET BROCHAGE“

Per ulteriori informazioni vogliate richiedere il catalogo „GOLE E STOZZATURA“



**D 041 VL**  
**0,4-1 Nm**

**Tournevis dynamométrique avec graduation**  
- réglage variable du couple  
- le couple ajusté est indiqué sur le cadran

Le couple peut être ajusté à l'aide d'un outil spécial de réglage du couple (inclus).

**Poignée :** Forme ergonomique offrant une parfaite maniabilité. Signal sonore lorsque le couple réglé est atteint.

**Norme :** EN ISO 6798, BS EN 26789, ASME B 107.14.M

**Précision :**  $\pm 6\%$



**D 15 VL**  
**1-5 Nm**

**Cacciavite dinamometrico graduato**  
- impostazione variabile della coppia  
- la coppia regolata viene visualizzata sul display

La coppia può essere regolata con un apposito regolatore di coppia (incluso).

**Impugnatura:** La forma ergonomica offre una perfetta maneggevolezza. Segnale acustico al raggiungimento della coppia impostata.

**Standard:** EN ISO 6798, BS EN 26789, ASME B 107.14.M.

**Precisione:**  $\pm 6\%$



**D 28 VL**  
**2-7 Nm**

**Dispositif pour le réglage du couple requis**

**Poignée :** En cellulose avec une surface micro-structurée

**Lame :** Lame octogonale (8 plats), galvanisée et trempée.



**ED 28 VL**

pour / per  
D041VL / D15VL / D28VL

**Dispositivo per l'impostazione della coppia richiesta**

**Impugnatura:** Cellulosa-acetato con superficie micro-strutturata

**Lama:** Lama ottagonale (8 lamelle), zincata e temprata



**D515QL**

**5-14 Nm**

### Tournevis dynamométrique avec graduation

- réglage variable du couple
- le couple ajusté est indiqué sur le cadran

Le couple peut être ajusté à l'aide d'un outil spécial de réglage du couple (inclus).

**Poignée :** Forme ergonomique offrant une parfaite maniabilité. Signal sonore lorsque le couple réglé est atteint.

**Norme :** EN ISO 6798, BS EN 26789, ASME B 107.14.M

**Précision :**  $\pm 6\%$

### Cacciavite dinamometrico graduato

- impostazione variabile della coppia
- la coppia regolata viene visualizzata sul display

La coppia può essere regolata con un apposito regolatore di coppia (incluso).

**Impugnatura:** La forma ergonomica offre una perfetta maneggevolezza. Segnale acustico al raggiungimento della coppia impostata.

**Standard:** EN ISO 6798, BS EN 26789, ASME B 107.14.M.

**Precisione:**  $\pm 6\%$



**ED515QL**

pour / per  
D515QL

### Dispositif pour le réglage du couple requis

**Poignée :** En cellulose avec une surface micro-structurée

**Lame :** Lame octogonale (8 plats), galvanisée et trempée.

### Dispositivo per l'impostazione della coppia richiesta

**Impugnatura:** Cellulosa-acetato con superficie micro strutturata

**Lama:** Lama ottagonale (8 lamelle), zincata e temprata



**DT6PK**  
**DT7PK**  
**DT8PK**  
**DT9PK**  
**DT10PK**  
**DT15PK**  
**DT20PK**  
**DT25PK**

pour / per  
 D041VL / D15VL / D28VL



Plus

### Embout pour vis TORX PLUS®

**Lame :** Acier Chrome-Vanadium de haute qualité, trempé à cœur, chromé. La lame Wiha Chrome garantit une précision maximale.

Code couleur : vert foncé

**Utilisation :** Réglage contrôlé de la vis avec un couple défini en combinaison avec le manche du tournevis dynamométrique Wiha.

### Inserto per viti TORX-Plus®

**Lama:** acciaio al cromo vanadio di alta qualità, temprato e cromato. La lama Wiha Chrome garantisce la massima precisione. Codice colorato verde scuro

**Utilizzo:** Regolazione controllata della vite con coppia definita in combinazione con l'impugnatura del cacciavite dinamometrico Wiha.



**DT6K**  
**DT8K**  
**DT15K**

pour / per  
 D041VL / D15VL / D28VL



### Embout pour vis Torx

**Lame :** Acier Chrome-Vanadium de haute qualité, trempé à cœur, chromé. La lame Wiha Chrome garantit une précision maximale.

Code couleur : vert foncé

**Utilisation :** Réglage contrôlé de la vis avec un couple défini en combinaison avec le manche du tournevis dynamométrique Wiha.

### Inserto per viti Torx screws

**Lama:** acciaio al cromo vanadio di alta qualità, temprato e cromato. La lama Wiha Chrome garantisce la massima precisione. Codice colorato verde scuro

**Utilizzo:** Regolazione controllata della vite con coppia definita in combinazione con l'impugnatura del cacciavite dinamometrico Wiha.



**DT15PQ**  
**DT20PQ**  
**DT25PQ**  
**DT27PQ**  
**DT30PQ**

pour / per  
 D515QL



Plus

### Embout pour vis TORX PLUS®

**Lame :** Acier Chrome-Vanadium de haute qualité, trempé à cœur, chromé. La lame Wiha Chrome garantit une précision maximale.

Code couleur : vert foncé

**Utilisation :** Réglage contrôlé de la vis avec un couple défini en combinaison avec le manche du tournevis dynamométrique Wiha.

### Inserto per viti TORX-Plus®

**Lama:** acciaio al cromo vanadio di alta qualità, temprato e cromato. La lama Wiha Chrome garantisce la massima precisione. Codice colorato verde scuro

**Utilizzo:** Regolazione controllata della vite con coppia definita in combinazione con l'impugnatura del cacciavite dinamometrico Wiha.



**DSW15K**  
**DSW20K**  
**DSW25K**  
**DSW30K**  
**DSW40K**

pour / per  
 D041VL / D15VL / D28VL

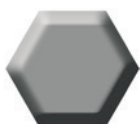

### Embout pour vis à tête creuse hexagonal

**Lame :** Acier Chrome-Vanadium de haute qualité, trempé à cœur, chromé. La lame Wiha Chrome garantit une précision maximale.

Code couleur : vert foncé

**Utilisation :** Réglage contrôlé de la vis avec un couple défini en combinaison avec le manche du tournevis dynamométrique Wiha.

### Inserto per viti a brugola

**Blade:** High quality Chrome-Vanadium steel, through hard  
**Inserto:** acciaio al cromo vanadio di alta qualità, temprato e cromato. La lama al cromo Wiha garantisce la massima precisione. Codice colorato rosso

**Utilizzo:** Regolazione controllata della vite con coppia definita in combinazione con l'impugnatura del cacciavite dinamometrico Wiha.

**DSW50K**  
**DSW60K**

pour / per  
 D15QL



### D14ZBK

pour / per  
D041VL / D15VL / D28VL

#### Embout universel pour embouts C6,3 et E6,3 (1/4")

**Lame :** Acier Chrome-Vanadium de haute qualité, trempé à cœur, chromé.

**Col :** Acier inoxydable

**Utilisation :** Pour un vissage contrôlé avec un couple défini en combinaison avec le manche du tournevis dynamométrique.

#### Chiave universale per punte C6,3 ed E6,3 (1/4")

**Inserto:** acciaio al cromo vanadio di alta qualità, temprato e cromato.

**Collare:** Acciaio inossidabile

**Utilizzo:** Per l'avvitamento controllato con coppia definita in combinazione con l'impugnatura del cacciavite dinamometrico.



### D14ZBQ

pour / per  
D515QL

#### Embout universel pour embouts C6,3 et E6,3 (1/4")

**Lame :** Acier Chrome-Vanadium de haute qualité, trempé à cœur, chromé.

**Col :** Acier inoxydable

**Utilisation :** Pour un vissage contrôlé avec un couple défini en combinaison avec le manche du tournevis dynamométrique.

#### Chiave universale per punte C6,3 ed E6,3 (1/4")

**Inserto:** acciaio al cromo vanadio di alta qualità, temprato e cromato.

**Collare:** Acciaio inossidabile

**Utilizzo:** Per l'avvitamento controllato con coppia definita in combinazione con l'impugnatura del cacciavite dinamometrico.



14ZQK

## Clé Universel avec poignée en T pour C6,3 et E6,3 (1/4")

**Lame :** Acier Chrome-Vanadium de haute qualité, trempé à cœur, chromé.

**Col :** Acier inoxydable

**Utilisation :** Pour une ouverture contrôlée

## Chiave universale con impugnatura a T per punte C6,3 and E6,3 (1/4")

**Blade:** High quality Chrome-Vanadium steel, through hardened, chrome plated.

**Collar:** Stainless steel

**Utilization:** For controlled opening



T6PW  
T7PW  
T8PW  
T9PW  
T10PW  
T15PW  
T20PW  
T25PW  
T30PW



Plus

## Clé pour vis TORX PLUS®

**Utilisation :** Pour tout type d'utilisation des vis TORX PLUS®

**Attention :** La clé TORX PLUS® ne convient pas aux vis Torx.

## Chiave per viti TORX PLUS®

**Utilizzo:** Per tutti i tipi di utilizzo delle viti TORX PLUS®.

**Attenzione:** La chiave TORX PLUS® NON è adatta alle viti Torx.

Type Tipo	Page Pag.
001C	74
105	76-82, 84-135, 149-152
106	201-203
107	209-213
108	219-221, 223-225, 227, 229-234, 237-238,
110	186-192
111	258-260, 262, 263, 265, 267-273, 276, 277
114	303-305, 307, 309-312, 314-320, 323-329
116	336-338, 340-342, 344-349, 352, 353
962	39
963	40
11P	284, 286, 287, 289, 291-293
18P	360
A105	147-148
A110	195-196
AIH	41
B105	15-16, 19, 21, 23, 25, 26-31, 34-35, 65, 135, 138-146
B105C	70-71, 136
B105TS	72-73
B106	200
B107	208
B108	218
B110	178-179, 194
B110C	181-182
B110TS	180
B111	256-257
B114	298-299
B116	334-335

Type Tipo	Page Pag.
B11P	282-283
B18P	358
BA114	301
BGT	45-46, 48-49
BKT	47, 50, 51
BU105	17, 20, 22
G	52
H105	36
HC105	37-38, 42
HC114	302
HF.N	66-67
HSKT40	68, 137
HVR.40	64
IR105	32-33
KC760	44
L760	43
N	55-61, 184
S105	83
S108	222, 226, 228, 235-236
S111	261, 264, 266, 274-275
S114	306, 308, 313, 321-322
S116	339, 343, 350-351
S11P	285, 288, 290
S18P	359, 361, 362
VDI	69, 183
WFB.105	75
WFB.110	185
WFB.114	300
Z	53





**TROUVEZ MAINTENANT VOTRE SOLUTION  
D'OUTILLAGE APPROPRIÉE.**

TROVA L'UTENSILE ADATTO PER TE.

[horn-group.com](http://horn-group.com)

**ALLEMAGNE, SIÈGE SOCIAL**  
SEDE PRINCIPALE, GERMANIA

—  
Hartmetall-Werkzeugfabrik  
Paul Horn GmbH  
Horn-Straße 1  
72072 Tübingen

Tel +49 7071 7004-0  
Fax +49 7071 72893

[info@de.horn-group.com](mailto:info@de.horn-group.com)  
[horn-group.com](http://horn-group.com)

**FRANCE**

—  
HORN S.A.S  
665, av. Blaise Pascal,  
Zone Industrielle  
F-77127 Lieusaint

Tel +33 1648859-58  
Fax +33 1648860-49

[infos@fr.horn-group.com](mailto:infos@fr.horn-group.com)  
[horn-group.com](http://horn-group.com)

**ITALIA**

—  
Febametal S.p.A.  
Via Grandi 15  
I-10095 Grugliasco

Tel +39 011 770 14 12  
Fax +39 011 770 15 24

[febametal@febametal.com](mailto:febametal@febametal.com)  
[www.febametal.com](http://www.febametal.com)