

No
01

world^{of} tools



20
26

THE HORN MAGAZINE



LADIES AND GENTLEMEN,



Our precision tools are used in a wide variety of industries. This issue of our world of tools provides an insight into this. We look at the machining of components for the marine, medical, defence and jewellery industries.

As is well known, precious metals are often used for making rings. As a precision tool manufacturer, we not only have to master our tools, but the entire process in order to achieve the best possible result for our customers, so we are also sharing our expertise regarding the properties of specific materials. Additionally, we are providing news from our international locations, with a focus on the USA, France and China.

We are confident that the following pages will provide you with information that is exciting, interesting and offers you valuable technical insights.

Two handwritten signatures in black ink. The signature on the left is 'Markus Horn' and the signature on the right is 'Matthias Rommel'.

Markus Horn and Matthias Rommel, Managing Directors, Paul Horn GmbH

world^{of} tools

Nº 01 2026

04

SHIPBUILDING

A Frenchman and the crazy Dutchman – nothing is impossible

10

PRODUCTS

Supermini for system interfaces
Superior chip control during grooving and parting off
High-calibre tools for shiny rings
New generation of ball nose end mills

16

SAFETY AND RELIABILITY

One tool, one set-up

19

HORN WORLDWIDE

Interview with Chad King
Guest commentary Miles Free
HORN (Shanghai) Trading Co. Ltd. expands
HORN France – an overview

24

MEDICAL INDUSTRY

Slot broaching in the medical industry

28

ABOUT US

Features of the slot broaching system

30

JEWELLERY INDUSTRY

Wedding rings 4.0

34

MATERIALS

Precious metals: beyond the bling

Imprint: world of tools®, HORN's customer magazine, is published twice a year and is sent to customers and interested parties. Publication date: March 2026. Printed in Germany.

Publisher: Hartmetall-Werkzeugfabrik Paul Horn GmbH • Horn-Straße 1 • D-72072 Tübingen • Tel.: 07071 7004-0
Fax: 07071 72893 • E-mail: info@de.horn-group.com • Internet: www.horn-group.com

Rights: Reprints, including extracts, only with the written permission of the publisher and the text and image reference "Paul Horn magazine world of tools®". Further text & image credits: Christian Thiele, Nico Sauermann, Win, Adobe Stock

Circulation: 20,300 in German, 5,300 in English, 3,360 in French

Editors/Texts: Nico Sauermann, Jessica Nossek, Christian Thiele

Complete production: Werbeagentur Beck GmbH & Co. KG • Alte Steige 17 • D-73732 Esslingen



A FRENCHMAN AND THE CRAZY DUTCHMAN – NOTHING IS IMPOSSIBLE

"Sometimes people thought we were both crazy," jokes Joop Nijland as he talks about his experiences. Together with HORN technician Roger Kasper, Nijland has spent the last 30 years devising tool solutions that have left many people shaking their heads. His expertise in tricky tool solutions earned him the nickname "the crazy Dutchman". One of these solutions can be seen in the milling of a round thread used in shipbuilding at Kooiman Marine Group, near Rotterdam. Milling the thread having a diameter of 400 mm (15.748") and a pitch of 40 mm (1.574") increased production quality and led to significant time savings.



In three decades of working together, Kasper and Nijland developed complex tool solutions, some of which are unrivalled. From initial sketchy ideas to complex multi-stage tool systems, they demonstrated the ability to turn technical challenges into workable solutions. "Sometimes people shook their heads when we proposed our ideas. However, the HORN designers almost always turn them into functioning tools," says Kasper. Nijland adds: "Without the design department at HORN, our ideas would often have come to nothing. They do a very good job."

TRICKY MILLING TASK

Nijland previously worked as a technical sales representative for the Dutch HORN agency Harry Hersbach. Kasper, on the other hand, was his contact at HORN, responsible for technical consultancy for France and the Benelux countries. One of their most recent major projects concerned the milling of threads having a round profile. Turning was not possible due to the component geometry. The threads have 32 mm (1.259") and 40 mm (1.574") pitches and diameters ranging from 400 mm (15.748") to 500 mm (19.685"). The depth and width of the individual threads are around 40 mm (1.574"). The thread is subjected to high tensile loads during use. Accordingly, the quality requirements are high and the tolerances tight. Nijland and Kasper set themselves the task of milling the thread in a single cut.

NIJLAND WAS RESPONSIBLE FOR TECHNICAL CONSULTANCY FOR FRANCE AND THE BENELUX COUNTRIES.

"The crazy Dutchman has another wild idea. That was the first reaction of the designers in the technical office," laughs Kasper. On closer inspection, the idea in CAD grew into a finished tool solution. Simply put, the milling cutter has six teeth or cutting levels having a diameter of 300 mm (11.811"). However, each of the six



Vessel turnaround time in shipyards is rapid using Kooiman services.



The tool with six cutting levels mills the round profile, 40 mm pitch thread in a single pass.

teeth consists of several individual cutting edges with different profiles. They produce the desired thread profile in a single pass. HORN uses indexable inserts of types S279 and 409 for this. The double-edged type 279 inserts are precision-ground to a special shape to mill the thread radii. Type 409 inserts from HORN's standard portfolio support the process by providing efficient metal removal from other areas of the thread.

HIGH MILLING PERFORMANCE

Due to the high surface finish requirements, the Kooiman team split the machining into two cuts. The tool mills the round thread profile at a cutting speed of 220 m/min (721.785 ft/min), with a finishing allowance of 2 mm (0.079"). Finishing is carried out at a cutting speed of 280 m/min (918.635 ft/min). Tool life is three finished threads per cutting edge. Machining time for both operations is around three hours. The milling process is dry. "We are delighted with how the tool performs. Compared to the previous machining process, the quality is much higher," says Kooiman Production Manager Lawrence Kooij.



Great attention is paid to thread quality.

KOOIMAN INVESTED IN A MACHINING CENTRE FROM RETOS.

Round threads transmit high forces thanks to even load distribution and precise thread engagement. The cylindrical geometry and continuous threads create a larger contact area, which minimises stress concentrations and improves load absorption. The uniform application of forces along the thread contour increases load-bearing capacity and rigidity, while reducing torsion and bending stress. Round threads enable high bolt and nut stiffness, reduced play and secure fastening over long engagement lengths. This is a particular advantage in vibration- or safety-critical applications.

LARGE PARTS, LARGE MACHINES

Anyone who produces large parts needs machines of appropriate size. Kooiman recently invested in a machining centre from Retos. The RETOS RET10P is a powerful universal milling/turning platform for the precision machining of large components. It combines a robust structure, high rigidity and modern CNC technology to reliably



A successful collaboration: Lawrence Kooij (bottom left), Nardo van den Berge, Roger Kasper, Ton de Pee, Joop Nijland and Nico van der Velden.



No rejects allowed: Given the high component cost, great care is required during set-up and production.

produce complex components. With its precise kinematics, the machine achieves excellent repeatability. High clamping force, low-vibration machining, integrated tool changing and minimal set-up times are outstanding features.

REPAIR AND NEW SHIPS

The Kooiman Marine Group offers a comprehensive portfolio of services along the entire value chain for ships and offshore installations. From engineering, design and manufacturing to maintenance, repair and retrofit, the company covers core competences such as mechanical production, marine equipment, propulsion technology, construction services and repair and spare parts management. Comprehensive solutions include project management, quality and safety management, logistical coordination and around-the-clock technical support. Customers benefit from customised, efficient and reliable services that combine global standards with local requirements and take sustainable practices into account.

In addition, the Group offers integrated services with a focus on reliability, availability and optimisation of operating costs. This includes comprehensive maintenance, modernisation and retrofitting of existing fleets, customised maintenance contracts, spare parts strategies and flexible logistics and procurement offers. Through lean processes, quality assurance to high standards and close cooperation with customers, the Kooiman Marine Group delivers long-lasting solutions, reduces downtime and ensures operational efficiency throughout the entire life cycle of the vessels.

WORK TURNED INTO FRIENDSHIP

The decades of collaboration also resulted in a close friendship between Kasper and Nijland that grew beyond professional boundaries. Shared travel and extensive debriefing sessions in hotels created a foundation for reliability and respect. There was never an issue that they could not resolve together, nor a conflict that could not be overcome through open dialogue and a solution-oriented approach. This connection made the collaboration not only productive but also fulfilling, as friendship and profession merged. Now both are retiring at the same time. "Now it's the turn of the youngsters, who are already motivated and waiting in the wings," says Nijland.



30 YEARS

In summary, the long-standing collaboration between Kasper and Nijland shows how creative tool solutions can significantly increase production quality. The joint development of HORN's round thread milling system achieves long tool life and short machining times. Over three decades, ideas have been successfully implemented, trust has been built up and ultimately a close friendship has been forged. Not only has the Kooiman Marine Group benefited from this duo, but numerous other customers as well.

PRODUCTS

SLOT BROACHING FOR SMALL DIAMETERS

HORN is expanding its slot broaching system with new type 117 inserts, which are suitable for internal diameters from 9 mm (0.354"). The tool system is sustainable thanks to the low carbide content, which results in a favourable price per cutting edge. HORN has developed a new carbide blank specifically for the 117 insert family. "The development of the new blank required new approaches in production and measurement. Due to the small size of the inserts, we had to make some changes in handling, fixture grinding and metrology," says HORN Product Manager Andreas Härle. The system is suitable for numerous processes such as gear broaching, polygonal broaching and the broaching of keyways.



Compared to solid carbide broaching tools, the new system has the advantage of longer tool shanks and therefore enables machining of longer or deeper grooves. Tool lengths are 20 mm (0.787"), 30 mm (1.181") and 40 mm (1.574"). All variants offer an internal coolant supply directly to the cutting zone. The shank diameters of the tool holders are 16 mm (0.631") and 20 mm (0.787"). HORN also offers special holders for mounting in broaching units from various manufacturers. The standard inserts are available in numerous variants.

The new broaching system has already shown its capability during initial applications. One user previously achieved a solid carbide tool life of 120 pieces when machining a serration in a component made of hardened steel. By switching to the new HORN carbide insert system, tool life increased to 1,040 components with the same cutting parameters. In addition to the significantly improved tool life, production costs fell due to the lower cost per cutting edge compared to that of the previously used solid carbide tools.



SUPERMINI FOR SYSTEM INTERFACES

SUPERMINI FOR SYSTEM INTERFACES

HORN is expanding its Supermini tool system with new holder variants. The holder programme is aimed specifically at use in modern turning/milling centres. The tool manufacturer is reducing the number of interfaces between the cutting insert and the machine spindle compared to conventional tool holding. This enables greater precision and higher process reliability. HORN offers the holder system with different machine interfaces. These include: HSK-T63, HSK-E40 for Willemin-Macodel, HSK-A40 for Bumotec and HSK-T40 for all other multitasking machines. In all variants, the Supermini insert is clamped using a face clamping or lifting element. Clamping does not take place via the lateral surface of the tool, but via a clamping wedge on the face. This results in a higher holding force on the insert and therefore better rigidity of the overall system.



Boring, profile turning, internal grooving, thread turning, chamfering, axial grooving, drilling and broaching: The Supermini tool system can be adapted and used for numerous machining operations. The carbide insert is used for machining bores from 0.2 mm (0.008") to around 10 mm (0.394") in diameter. HORN developed the blank of the tool as a teardrop shape, which enables precise contact surfaces in the tool holder. Furthermore, the teardrop shape prevents the insert from twisting, which results in a consistently precise position of the centre height of the tool. With long tool overhangs, it reduces deflection and minimises vibrations during turning. Depending on the application and the diameter to be machined, HORN offers the insert in three different sizes: Type 105, 109 and 110. All variants allow internal coolant supply directly to the cutting zone. The HORN tool portfolio contains around 2,500 different standard variants of the Supermini. In addition, HORN solves users' machining problems with countless customised solutions.



FACTS

- High-precision insert seat with optimised clamping
- Direct mounting for high stability and precision
- With internal coolant supply

**THE TOOL SYSTEM CAN BE CUSTOMISED FOR
NUMEROUS MACHINING OPERATIONS.**

SUPERIOR CHIP CONTROL DURING GROOVING AND PARTING OFF

SUPERIOR CHIP CONTROL DURING GROOVING AND PARTING OFF

Paul Horn GmbH has introduced a new chip breaker geometry for the 274 tool system especially for grooving and parting off on sliding-head lathes. The sintered chip breaker geometry 1A optimises chip control during turning, ensuring a high level of process reliability. The universal geometry is suitable for machining various materials. The indexable insert with two cutting edges is available in three cutting widths of 1 mm [0.039"], 1.5 mm [0.060"] or 2 mm [0.079"]. Maximum grooving depth is between 3 mm [0.118"] and 6 mm [0.236"]. The insert is available in TH35 and IG35 grades. An extensive range of holders is available for adaptation to different types of lathe.

When machining turned parts of small diameter, the centre height of the tool must be precise. Even small deviations in the centre height have a negative effect on the quality of the workpiece when machining very small parts. Ideally, the machine operator should be able to index the insert without having to readjust the centre height. With System 274, HORN offers excellent repeatability of less than 0.02 mm [0.001"] when turning the double-edged insert. This is made possible by precise peripheral grinding of the insert in conjunction with the stable insert seat.

THE UNIVERSAL GEOMETRY IS SUITABLE FOR MACHINING VARIOUS MATERIALS.



FACTS

- Precision sintered chip breaker geometry 1A
- For reliable grooving on sliding headstock lathes
- Specially designed for long-chipping materials



HIGH-CALIBRE TOOLS FOR SHINY RINGS

HIGH-CALIBRE TOOLS FOR SHINY RINGS

With its newly developed ring production programme, HORN offers a range of diamond tools for roughing and finishing of jewellery rings, as well as the appropriate holder systems for external and internal machining. HORN has completely reconfigured the polycrystalline roughing tools to enable reliable high-polish finishing with monocrystalline diamond. These are now capable of economically processing all precious metals, including platinum and iridium. With this complete system, HORN offers a unique selling point in the industry.

Benzinger machines, in particular the "GoRing" model series, are at the centre of ring production. The tool concept was developed in close cooperation with Benzinger and optimised over many years. Users appreciate the user-friendly and precise HORN changeover system, which reduces set-up times to a minimum. Of course, the HORN tool systems can also be used successfully on all other machine tools.

HORN INCORPORATED PROVEN TOOLS FROM ITS EXISTING TOOL PROGRAMME.



HORN has incorporated proven tools from the existing tool programme. The interfaces remain unchanged and are supplemented by the HORN 11P system. In addition to greater precision, this offers the advantage of combining external and internal machining in one tool. In addition to the standard programme, HORN offers numerous special solutions tailored to specific requirements.



FACTS

- Comprehensive range of tools for jewellery ring production
- High-precision cutting edges in MCD and PCD versions
- Reduced set-up time due to precision insert seat



NEW GENERATION OF BALL NOSE END MILLS

FACTS

- Smooth cutting action via helical ramping
- 23 per cent higher rigidity thanks to improved interface
- Optimised internal coolant supply

NEW GENERATION OF BALL NOSE END MILLS

With the new KX system, HORN is launching a high-performance solution for the economical and reliable machining of ball bearing tracks. HORN developed the system specifically to meet the increasing demands for precision, flexibility and productivity in the production of constant velocity joints. The system covers a wide range of components and offers three sizes. Flexible machining strategies enable both soft and hard machining – from roughing and chamfering to finish milling. Customers can adapt the strategy precisely to their process requirements, ensuring a high level of cost-effectiveness.

USERS SIGNIFICANTLY INCREASE CUTTING VALUES AND NOTICEABLY REDUCE CYCLE TIMES.

With the KX system, HORN has considerably increased the performance of the tool system. Soft-cutting cutting heads with defined edge preparations enhance process reliability. Precise internal coolant positioning and a newly developed interface improve rigidity. Practical benchmarks confirm the performance: Users significantly increase cutting values and noticeably reduce cycle times. Depending on the component, they shorten the machining time by several seconds per work-piece and sustainably increase productivity.

Constant velocity joints are used in every car and are also known as homokinetic joints. Their purpose is to transmit uniform torque and angular speed from the drive shaft to a second shaft mounted at an angle to it. In other words, constant velocity joints transmit rotary motion uniformly to the next shaft. The joints are most widely used in vehicle construction for power transmission from the gearbox to the drive wheels. Constant velocity joints can transmit rotational movements at an angle of up to 50 degrees. In addition to fixed ball joints, sliding constant velocity joints are also used. They allow not only angular movement, but also axial movement so that power transmission is not interrupted when steering or during movement of the suspension.



At the heart of a homokinetic joint are the balls, which roll in precisely milled tracks. The ball tracks have a very tight manufacturing tolerance and a high surface finish is essential. The tight tolerances and the manufacturing quality determine how long the service life of the joints will be. The form tolerances of the parameters are to within microns.

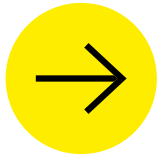

ONE TOOL, ONE SET-UP

When the previous supplier pulled out, the customer had only one option: to find a partner who would not simply copy what already existed, but would rethink the application. For EMCO Gears, a family-run company with deep roots in precision, motorsport and high technology, this was precisely the incentive. Together with tool partner HORN USA, a modern manufacturing approach was developed for a demanding bevel gear set with an unusual geometry. Design, tooling, five-axis machining and metrology are seamlessly integrated – and show how gears can be manufactured efficiently, reproducibly and with future-proof technology.

EMCO Gears is a family-owned and operated manufacturer with two locations: engineering and manufacturing in Elk Grove Village, Illinois, and a second location in Indianapolis, Illinois, which supports racing services and sales. EMCO serves the motorsport, defence, aerospace and industrial sectors with a common focus: the supply of highly engineered parts where material selection, heat treatment and manufacturing strategy are as important as the design specification. For this application, EMCO was asked to manufacture a bevel gear set for a customer whose previous supplier had stopped producing the parts. EMCO agreed on one condition: The gear set was to be manufactured using a modern approach.

A 60-DEGREE BEVEL GEAR SET

The gear set is used in a PTO (power take-off) assembly. Typically, bevel gear applications have a 90-degree power transmission, but this project required a 60-degree design. This difference affects the gear geometry, contact ratio and the manufacturing process required to achieve these goals.

Changes in the profile, position or stability of the gear set elements quickly become noticeable in the form of noise, heat, wear or premature failure. With a very small margin for error, repeatability is critical.

The gear is manufactured from SAE 9310/14NiCrMo 13-4 (1.6657), a steel alloy with a high nickel and chromium content offering good strength and hardenability. After case hardening, the gear develops a hardened surface while the core remains tough. This provides a combination of surface strength and underlying toughness suitable for demanding duty cycles.

BEYOND THE LIMITS OF TRADITIONAL BEVEL GEAR PROCESSES

Once the cutter diameter is selected, development can often be restricted by that specific tool. EMCO had a different goal. The team wanted the freedom to design the required tooth form and then produce it on a five-axis machine with a tool that cuts both sides of the tooth profile in one pass. The resulting solution is based on a bevel gear milling tool specifically developed for EMCO's five-axis strategy. "In the past," says Wolfe, "four special tools had to be used. We can now achieve the tooth profile with just one special tool." Implementation was quick, as HORN was already familiar with EMCO's spindle interface on the DMG five-axis machine. For the indexable inserts, HORN started with a proven profile shape and modified the profile to obtain the required cutting edge.



60-degree PTO bevel gear set for a military land vehicle.



3.5 inch diameter cutter with 12 insert positions; inserts customised for EMCO's tooth form.

The workflow at EMCO combines design, production and measurement. The team mills the gears, checks the topography on a Zeiss CMM and updates the program if necessary. The advantage of this is that dimensional adjustments to the teeth can be made without changing tools.

FROM 8 HOURS TO 15 MINUTES

Before the HORN milling cutter was introduced, helical gears were produced with small end mills and conservative cutting parameters, with the machining of a single gear taking around 8 hours of machine time. With the new process, milling the teeth now only takes around 15 minutes, followed by metrology and any necessary program updates. Wolfe emphasises that the implementation depends on realistic starting parameters. He describes the cutting data recommended by HORN as practical and accurate, which supports stable production.

SLOT BROACHING SYSTEM IN OPERATION

In addition to bevel gear cutting, EMCO focused on slot broaching. To ensure a continuous process flow, EMCO integrated the broaching onto the lathe using the HORN N117 system. Wolfe describes the new process: "Instead of waiting for a batch to be completed, the parts are passed from turning to subsequent operations with a more consistent flow. A custom insert is used. We wanted special corner radii for greater strength and HORN adapted the cutting edge profile accordingly."

THE WORKFLOW AT EMCO COMBINES DESIGN, PRODUCTION AND METROLOGY.

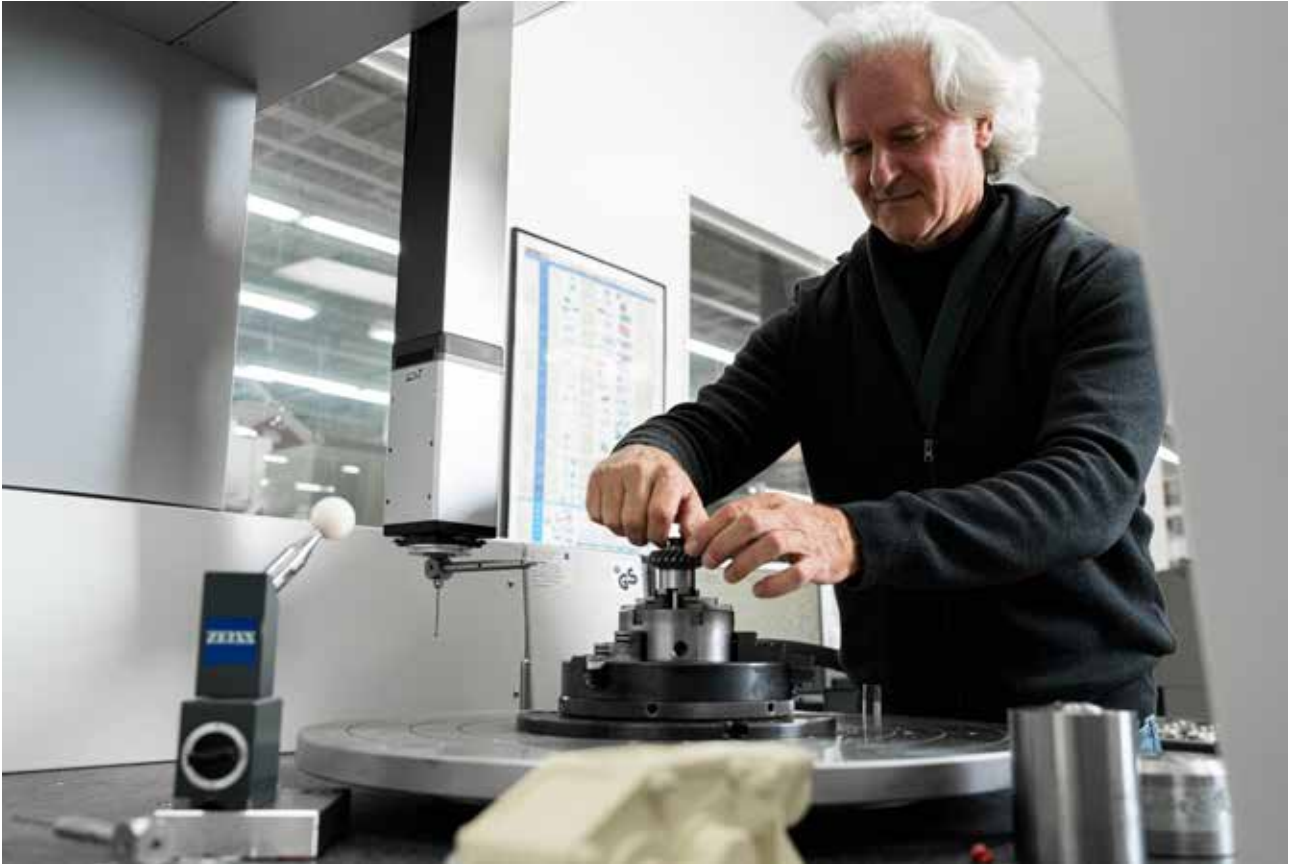

Topography feedback enables rapid refinement of the contact pattern.

Both Wolfe and Bruce Williams, Product Development Manager at EMCO, describe the collaboration with HORN as solution-oriented and responsive. Wolfe points to the quick communication between the sales contact and technical support, which helped clarify tool design details rapidly. Williams explained that while EMCO can define how a part should be machined, the benefit lies in having a tooling partner that can translate a particular requirement into a timely, usable solution. The result is a clear competitive advantage, allowing EMCO to bring the finished product to market faster.

POSITIVE OUTCOME

By combining five-axis manufacturing, Zeiss-based topography measurement, surface metrology and HORN's product portfolio, EMCO has a process for manufacturing bevel gears that was faster to develop, easier to operate and better aligned with actual production requirements. For EMCO, it means improved gear meshing, quieter operation, longer life and easier manufacturing, while meeting cost targets in a changing market.

IN ADDITION TO BEVEL GEAR CUTTING, EMCO FOCUSES ON SLOT BROACHING.



EMCO GEARS

EMCO Gears was founded in Chicago in 1934. Wolfe recalls the early days, when the company started with simple, mass-produced gears before transitioning to high-precision defence contracts. In motorsport, the company's role expanded from manufacturing to gearbox and systems design. Today, EMCO also applies the same problem-solving approach to the defence, aerospace and industrial sectors.

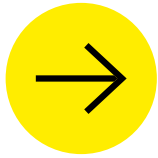

INTERVIEW WITH CHAD KING



Mr King, the HORN Group has been active in the USA since 1997. How is the company positioned today?

We have established a strong presence in the US, supported by local sales, manufacturing, design and technical teams. After nearly three decades in the market, many of our customers see HORN as a trusted manufacturing partner, relying on us to support process optimization, reduce cycle times, and improve cost per part, for example.

We take a consultative approach with our customers and work closely with them to deliver the best possible solution, whether that is a standard tool or a fully customized special solution. We are well positioned to be successful in the future. With the completion of our new building in 2020, we have expanded our capacity with additional grinding machines and an in-house coating facility and we still have ample room to grow.

What exactly does it mean when you say you manufacture in the USA?

When we say that we manufacture in the U.S., we mean that we have end-to-end manufacturing expertise. At our facility in Franklin, Tennessee, we can take a customer's part print, design a custom tool, grind the blank and apply our in-house coating. All under one roof. We don't just manufacture in the U.S., we manufacture for the U.S. and support the North American industry with speed, quality and local expertise.

In which core industries are your customers active in the USA?

Our core markets in the U.S. include Aerospace, Automotive, Defense and Medical. While we support a wide range of industries, we excel in applications where quality, precision and time matter most.



Chad King, CEO HORN USA.

How has the US market developed in recent years and what are your future prospects for HORN USA?

The US market continues to demand tighter tolerances, harder-to-machine materials and faster response times. Customers are increasingly looking for partners with strong technical knowledge and reliable manufacturing support.

HORN USA is prepared to meet these demands, combining the speed and quality of U.S. manufacturing with a strong technical team to support high-precision industries.

What events and trade shows will you be attending this year?

One of our most important trade shows in 2026 is IMTS Chicago. Here we will be showing everything a machinist's heart desires. We are also represented at numerous other trade fairs, such as Metalworking and Manufacturing Expo, ISA26, PMPA Tech Conference MMTS - Montreal Manufacturing and many more.

Come by and let's talk about machining.



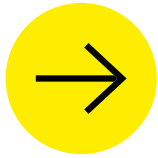

GUEST COMMENTARY MILES FREE

As precision machinists, we work in a process-oriented manner to ensure quality. Our processes note customer requirements, critical and key features, industry standards and specifications to ensure conformity and the satisfaction of our customers through the targeted use of tools, machines, software, materials and media. We also follow clearly defined standards in tool design to ensure the expected performance for the respective application.

But there is nothing in all these standards about how to create joy. Satisfaction is defined and measurable – joy is not. Our processes reliably ensure quality, but how often do we get to reflect on the joy, the delight, not just the satisfaction that our work truly delivers?

On my last visit to HORN Tübingen, I was recognized for my many years of service and received a WireStyle thread painting: an amazing three-dimensional rendering of my landscape photograph, made exclusively from nails and a string – without ink, without a hidden image. I was familiar with the technology and knew about the specially developed precision tools, but I was still deeply impressed by the result.

We are focussing on processes, tools, materials and products. That is right and necessary. But we should also think about the joy that comes from it: Cars that drive, aeroplanes that fly, people who are healed by precisely manufactured parts. In my case: the astonishment of seeing my photo transformed into a 3-dimensional realization of what I had seen.

Processes are discipline, not magic. And yet they create magic for our clients, their clients and ultimately for all of us. I look back on a fulfilling career – and a WireStyle thread image that combines my vision with my craft.

What delighted you today? When your everyday life works, thank a precision mechanic or toolmaker.

Thank you, HORN. Thank you, WireStyle – for delivering delight.



Miles Free, former Director of Industry Affairs PMPA.



WIRESTYLE

André Gall, founder of WireStyle, combines art, software and mechanical engineering to produce impressive thread images from photos. Using self-developed algorithms and machines, he creates detailed works of art at high speed from thousands of nails and kilometres of thread. Automated production makes thread pictures affordable for the first time and significantly shortens delivery times. Precision tools from Paul Horn GmbH enable the exact cutting and setting of up to 12 nails per second and ensure the necessary reliability. The special feature of the WireStyle images is the detailed visualisation using just a single thread, the course of which is precisely calculated by the software. Darker areas of the image receive more thread, lighter areas less, creating contrasts that would be almost impossible to realise by hand. Around 8,000 nails are placed and around 1,200 metres of thread are stretched per image. This is made possible by highly dynamic machines and precise cutting tools.

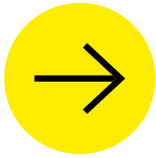

HORN (SHANGHAI) TRADING CO. LTD. EXPANDS

With its relocation on 9th December 2025, HORN (Shanghai) Trading Co. Ltd. has taken an important step for the long-term development of the HORN Group in the Chinese market. HORN Shanghai was founded in 2012 and sales activities started as early as 2013. Today, HORN employs 26 people in China. The country was one of the top 5 foreign markets for the tool manufacturer in 2025. This growth made it necessary to expand the office and warehouse space.



The relocation of HORN (Shanghai) Trading Co. Ltd. marks another important step for the company's growth in China and is also a clear commitment to the market.

The subsidiary moved into the new, modern office in the same district in Shanghai. At around 850 square metres (9,149.32 sq ft), it is almost twice as large as the previous location. In addition to significantly more space, the new office has a prestigious entrance area with a showroom and professional, flexible training rooms. This creates the ideal conditions for HORN's further growth in China – the company's aim is to double its size. Markus Horn, Managing Director of Paul Horn GmbH, and Andreas Vollmer, Head of Global Sales at Paul Horn GmbH, were on site for the inauguration and accompanied their colleagues from HORN Shanghai during the celebrations. Li Xiayang, Director of the district government in Shanghai, took part in the event.

TODAY, HORN EMPLOYS 26 PEOPLE IN CHINA, WHICH BECAME ONE OF ITS TOP 5 FOREIGN MARKETS IN 2025.

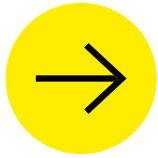

HORN FRANCE – AN OVERVIEW



HORN, headquartered in Tübingen (Germany), is a family-owned company specialising in precision tools. Since its foundation, the company has established itself as a key player in demanding industries such as automotive, aerospace, chemicals, medical, and tool and mould making. HORN is represented in more than 70 countries and offers over 25,000 standard tools and more than 200,000 customised solutions, with a focus on quality, performance and innovation.

The internationalisation of today's HORN Group began in the 1990s. The opening of a subsidiary in France, the group's first branch outside Germany, marked several milestones. Andreas Vollmer, Managing Director of HORN in France: "In 1993, thanks to two employees, Pascal and Didier Ortega, we started our own business activities in France. The encouraging results in the early days quickly prompted the management in Germany to officially establish HORN France in November 1995 with a team of five employees and a large warehouse in the Paris region."

TODAY, HORN HAS TWO BRANCHES IN FRANCE.

LARGER PREMISES

In 1997, the company moved to Moissy-Cramayel in order to have bigger premises for up to 20 employees and an even larger warehouse – now 450 m² (4,843.76 sq ft).

One year later, HORN France's workforce had increased to 12 employees, confirming the rapid growth of the subsidiary in the French market. In 1999, we established our second branch in France, HORN H. Savoie, based in Haute-Savoie, a key region for the production of turned parts, with a permanent warehouse and three dedicated employees. Vollmer: "In 2005, we were able to move into new premises in Lieusaint (Seine-et-Marne), which included a showroom. From then on, we were able to organise training courses and tool demonstrations on site. That was a big



leap forward for us." The most recent milestone came in 2025: a change in management. Pascal and Didier Ortega retired and handed over their duties and responsibilities to Olivier Rodrigues and Emmanuel Collomb. Vollmer: "I would like to take this opportunity to thank Pascal and Didier Ortega for our time together, for our shared achievements and successes and for the excellent teamwork. At the same time, I wish Olivier Rodrigues and Emmanuel Collomb every success in continuing this story. I look forward to what we can achieve with the entire French team in the future – supporting and developing our customers."

TWO BRANCHES

HORN France specialises in miniature machining and the manufacture of high-precision tools, such as the Supermini and Mini ranges from a bore diameter of 1 mm (0.039"), as well as a complete range for boring, grooving, threading and roughing. The company emphasises the performance and durability of its tools by reducing set-up times and improving machining quality. Today, HORN France has two branches. Lieusaint: where the head office with a showroom is located. Scionzier: a regional office located near the industrial centre for turned parts, where 65 per cent of the companies in the sector are based and therefore a large proportion of customers. HORN France continues to offer high-tech machining solutions, technical support and training for users, consolidating its position as a recognised specialist in the field of precision machining.



Andreas Vollmer



Pascal and Didier Ortega



Emmanuel Collomb



Olivier Rodrigues

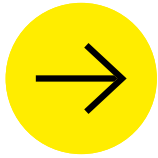

SLOT BROACHING IN THE MEDICAL INDUSTRY

Narrow slots, long tool life and a favourable cost per cutting edge? With the expansion of its slot broaching system, HORN demonstrates how the shaping process can be used economically in small diameters. For field tests, HORN looked for customers with special components and high quality requirements. A key component of a medical endoscope was ideally suited to this. The contract manufacturer Öschger GmbH from Emmendingen agreed to participate in the long-term tool tests and was impressed by the performance of the new system.

Medical endoscopes are important in modern medicine and are used for minimally invasive diagnostics and therapy in numerous medical disciplines. They enable the optical visualisation of body cavities and organs in real time and contribute significantly to the reduction of surgical trauma, shorter recovery times and increased patient safety. Technically, endoscopes consist of precise optical components, illumination units, mechanical structures and, increasingly, digital image sensors that provide high-resolution image data. Depending on the application, rigid or flexible designs are used, with flexible endoscopes having complex internal channels and movable segments. The materials used must be biocompatible, sterilisable, durable and meet strict requirements.

CUSTOMER QUESTION TO HORN

Several customers approached HORN to ask whether the existing 117 slot broaching system could be extended to accommodate smaller bore diameters. Previously, the minimum machining diameter was 14 mm (0.551"). For applications below this range, the Supermini 105 system was used from 6 mm (0.236") and Supermini 110 from 9 mm (0.354"). For slot broaching operations, the disadvantage of the 110 system was the high tool cost. The need for a more economical solution for the diameter range 9 mm (0.354") to 14 mm (0.551") was thus clearly defined and formed the basis for a new development project at HORN. The aim of the project was to strategically extend the 117 grooving programme downwards to cover the diameter range 9 mm (0.354") to 14 mm (0.551"). The focus was on a solution that could be integrated into existing processes, works reliably and at the same time reduces the cost per component.

Instead of a customised solution, a standardised tool system was to be developed that would offer users an alternative to the existing System 110. Harnessing the familiar System 117 meant that production, handling and use would remain as simple as possible.

The project work was spread across several specialist departments. Product management took on the role of project initiator and coordinator. The design department carried out fundamental research and



With the expansion of the 117 slot broaching system, HORN offers a practical internal machining solution for small-diameter holes.

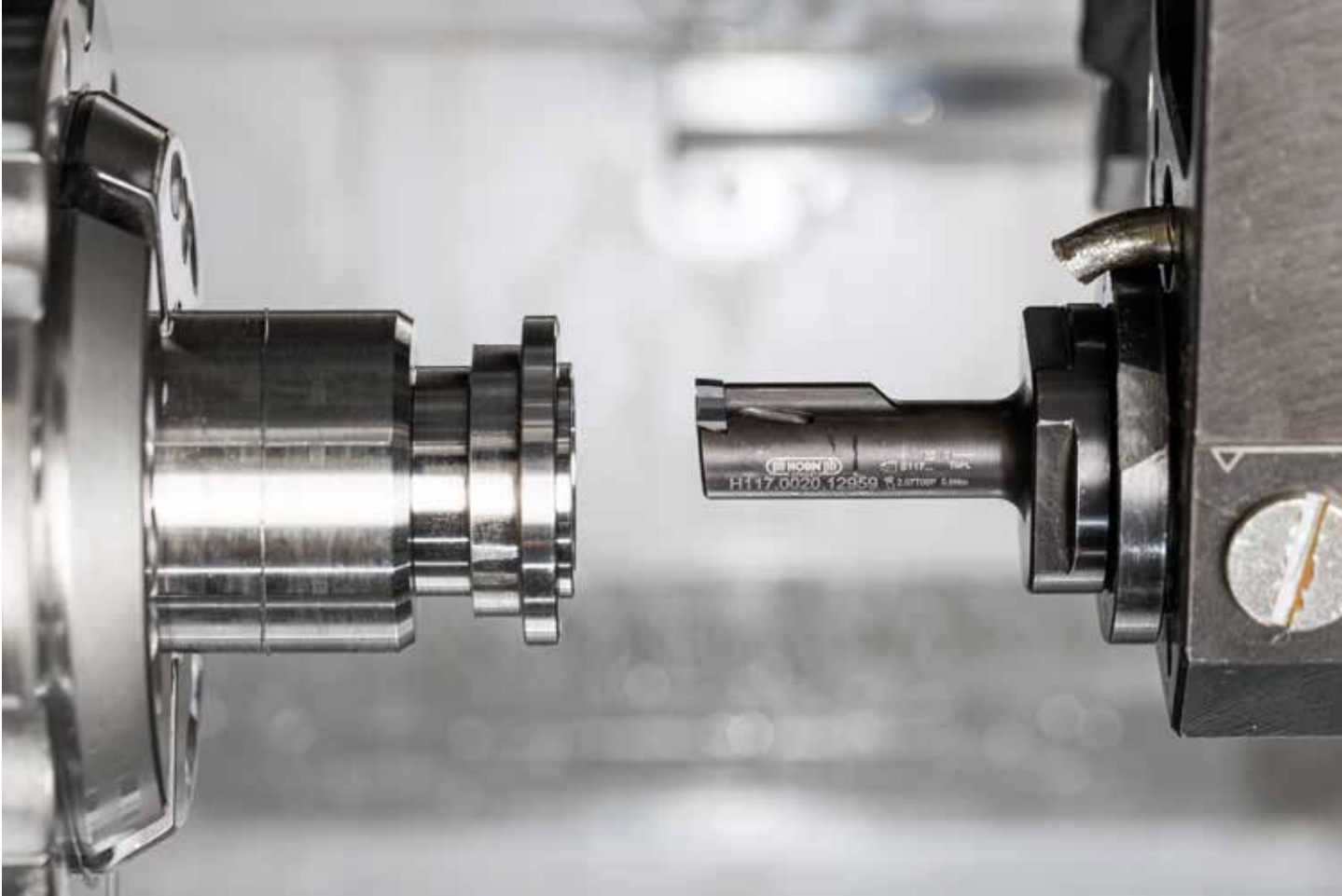

Major advantages of the new system are, firstly, the stability of the holder system and, secondly, the internal coolant supply directly to the cutting zone.

feasibility studies. Based on this, new tool holders and matching inserts were developed. At the same time, Research and Development analysed the stability of the holders using FEM calculations. The results were incorporated directly into the design and formed the basis for safe machining of small diameters.

Production and automation specialists were also involved in the project at an early stage. The team focused on the safe handling of the small inserts, the design of the clamping screw and its defined tightening torque. The constant torque on the screw ensures even, precise insertion into the insert seat, but must not be too high due to the fragility and small size of the screw. Another team was responsible for automating the grinding processes to ensure reproducible quality. The holders were manufactured in-house. The close cooperation between all those involved resulted in the extended application range of the 117 slot broaching system.

PRODUCT MANAGEMENT ASSUMED THE ROLE OF PROJECT INITIATOR AND COORDINATOR.



HORN supplied the new insert as a special tool for the field trial. It meant that the keyway was slotted and the edges chamfered with a single insert in the same broaching process.

FIELD TRIALS

After development, production planning and manufacture of the prototypes, the first trials are on the agenda. Every newly developed tool has to prove itself at this stage of development in the HORN test centre. Does it function as planned or does it require a design adjustment? This question is at the heart of every test. If they are successful, HORN specialists task the field sales engineers to find customers who will test the tools in real-world production environments. One such user was the company Öschger. "The endoscope component was an obvious choice," says Clemens Fürderer, head of the turning technology team at Öschger. The component, made from 1.4307 stainless steel, has an internal diameter of 13 mm (0.512"). The internal keyway is 2 mm (0.079") wide and 10 mm long (0.394"), with two defined 45-degree chamfers.

Before the tests with the new tool system, the team produced the keyway with two type 110 inserts, one of which slotted the groove and the other broached the edge chamfers. HORN then supplied a special insert for the field trial, whereby the groove is cut and the edges chamfered with the same insert in one process. Broaching takes place via reciprocating stroke movements of the tool turret. A separate broaching unit is not economically viable due to the relatively small batch sizes.

ADVANTAGES INCLUDE THE STABILITY OF THE TOOL HOLDER AND THE INTERNAL COOLANT SUPPLY DIRECTLY TO THE CUTTING ZONE.

SUCCESSFUL DEPLOYMENT

"After the first batch of components, the performance of the new tools was already apparent," says Fürderer, who continues: "We have already cut 2,500 keyways with the tool. There are still no signs of wear on the insert edge. It will probably last for another 2,500 machining operations." The tool previously used had a service life of just under 1,000 keyways. Major advantages of the new system are, firstly, the stability of the holder system and, secondly, the internal coolant supply directly to the cutting zone. "Besides the very good performance, the new tool also offers us considerable cost savings," says Fürderer. One of the reasons for these savings is that a significantly lower proportion of carbide is used in the insert.

With the expansion of the 117 slot broaching system, HORN offers a practical solution for small-diameter applications where process reliability and cost-effectiveness are equally important. The results from the field trials show that the system can be reliably integrated into existing production processes and enables stable broaching. Improved tool life, reduced tool costs and the combination of several machining steps in one tool have a positive impact on component costs.



ÖSCHGER GMBH

The company Öschger from Emmendingen is a specialist contract manufacturer of demanding medical components (ISO 13485), as well as CNC precision parts for other industries. Together with Oesterle+Partner, Öschger also specialises in the manufacture of driven tools for CNC lathes. The company manufactures complex components to high dimensional accuracy and consistent quality – from individual parts to series production. State-of-the-art CNC machines, precise measuring and testing technology and clearly structured processes ensure reliable results, even with the tight tolerances. Öschger partners with its customers from the initial technical consultation through production to on-time delivery. Technical expertise, process reliability and a strong commitment to quality make the company a high-performance partner for precision contract manufacturing.



Successful field trial: Clemens Fürderer in conversation with HORN sales representative Karl Schonhardt.



FEATURES OF THE SLOT BROACHING SYSTEM

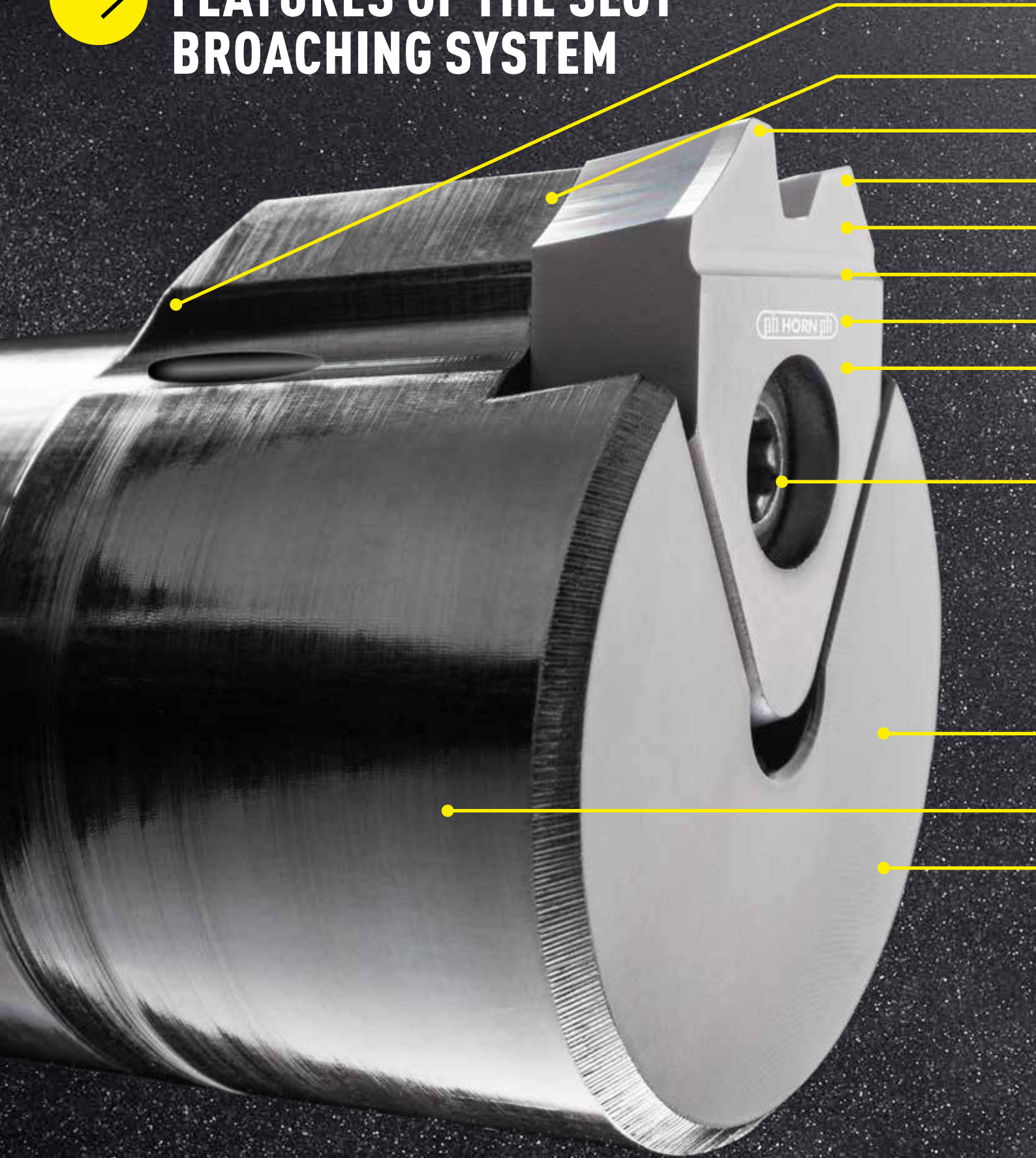

PATENTED INTERNAL COOLING FOR EFFICIENT CHIP EVACUATION AND HIGH SURFACE FINISHES

SUPPORT FOR ABSORBING CUTTING FORCES

ADAPTED MICROGEOMETRY FOR RELIABLE MACHINING

PRECISION-GROUND MACRO GEOMETRY

POSITIVE RAKE ANGLE FOR SOFT CUTTING

PROPRIETARY COATING FOR LONG TOOL LIFE

VARIOUS INSERT SIZES TO SUIT DIFFERENT BORE DIAMETERS

TOUGH CARBIDE SUBSTRATE FOR CONSISTENT PERFORMANCE

STABLE TORXPLUS® SCREW FOR PRECISE INSERT CLAMPING

PRECISION-MILLED INTERFACE FOR SECURE CLAMPING AND POSITIONING WHEN UNDERCUTTING

TOOL HOLDER ADAPTED TO THE BORE DIAMETER

BEVELLED SHAPE FOR IMPROVED CHIP REMOVAL

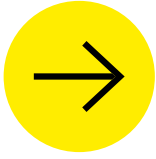

WEDDING RINGS 4.0

Young entrepreneurial courage meets traditional manufacturing – how three friends and fellow students are modernising and shaking up the wedding ring market and relying on precise technology. "We rely on an end-to-end process chain, from the 3D wedding ring configurator to CNC production and stone setting," says Thomas Junge. He manages the Hamburg-based company HCF Merkle together with Matthias Heerens and Benjamin Urland. The team relies on diamond tools from HORN and lathes from Benzinger to manufacture the wedding rings.

The wedding ring has a long, symbolic history dating back to ancient times. Even the Romans regarded the ring, often made of iron or bronze, later of gold, as a sign of union and fidelity. In the Christian tradition, it gained importance as a solemn symbol of marriage.

IN THE CHRISTIAN TRADITION, GOLD GAINED IMPORTANCE AS A CEREMONIAL SYMBOL OF MARRIAGE.

Over time, wedding rings became a symbol of a partner's commitment, accompanied by ritual acts such as exchanging rings and looking at each other's hands. In the Middle Ages, the focus shifted more towards gold as a sign of value and permanence. With modernity, design diversity and personalisation developed, but the central meaning remained unchanged: Connection, loyalty and remembrance.

HORN TOOL PORTFOLIO IN USE

"In the past, we had a diverse array of different tool systems. After acquiring the company, we wanted to standardise this approach and look for a primary supplier," says Junge. He and his team have found this supplier in HORN. The complete HORN tool portfolio for ring production is used on the lathes at Merkle. This includes standard tools as well as customised solutions specially configured for Merkle. The HORN tool system for ring production consists mainly of PCD-tipped inserts for roughing and MCD-tipped inserts for finishing and creating a mirror finish.

Depending on the cross-sectional profile, the blank of a ring has an allowance of around 0.3 mm (0.012").

Merkle receives the raw material as a tube in various diameters. The blank is then sawn from the tube according to the size of the ring. "We don't want to turn a 100 g (3.527 oz) solid piece of material into a 3 g (0.106 oz) ring. Then we would have to recycle 97 g (3.422 oz) afterwards, which would lead to unnecessary costs and tool wear," says Junge. Before being machined, the blank is placed on a fixture to stretch it to the desired size. This further compacts the alloy and any voids or pores in the raw material disappear. These could otherwise appear later as visual imperfections on the ring's surface.

UNIQUE SELLING POINT

During the production process, the machine first processes the outer surface of the ring. The blank is clamped into a collet for this purpose. The HORN System 11P with PCD-tipped insert is used. This pre-turns the outer contour with a defined allowance of 0.01 mm (0.0004") for gold alloys. Due to the poorer machinability of platinum alloys, the allowance for those is around 0.02 mm (0.001"). The ring is then moved to the next processing station in the machine. The high-gloss finishing process is carried out with an MCD insert. The machine then clamps the ring in an 8-jaw chuck and starts internal machining. The System 11P is used again for roughing. "In addition to its high precision, the 11P system offers the advantage that external and internal machining operations are combined in a single tool. This is a unique feature of our tool solution," explains HORN Product Manager Aribert Schroth. Finishing is then performed again with an MCD tool.

THE PINNACLE OF MACHINING

High-polish machining with MCD is one of the supreme disciplines when machining with geometrically defined cutting edges. A few hundredths of a millimetre of finishing allowance separate a very good surface from the "perfect" surface with a mirror finish. The range of applications is broad. The manufacturing process is used in numerous industries. In the jewellery industry, for example, the tools provide the brilliant shine when producing the visible parts of a high-quality wristwatch and wedding rings. In the production of mirrors for space telescopes, the almost perfect dimensional accuracy of the milled mirror surface guarantees a

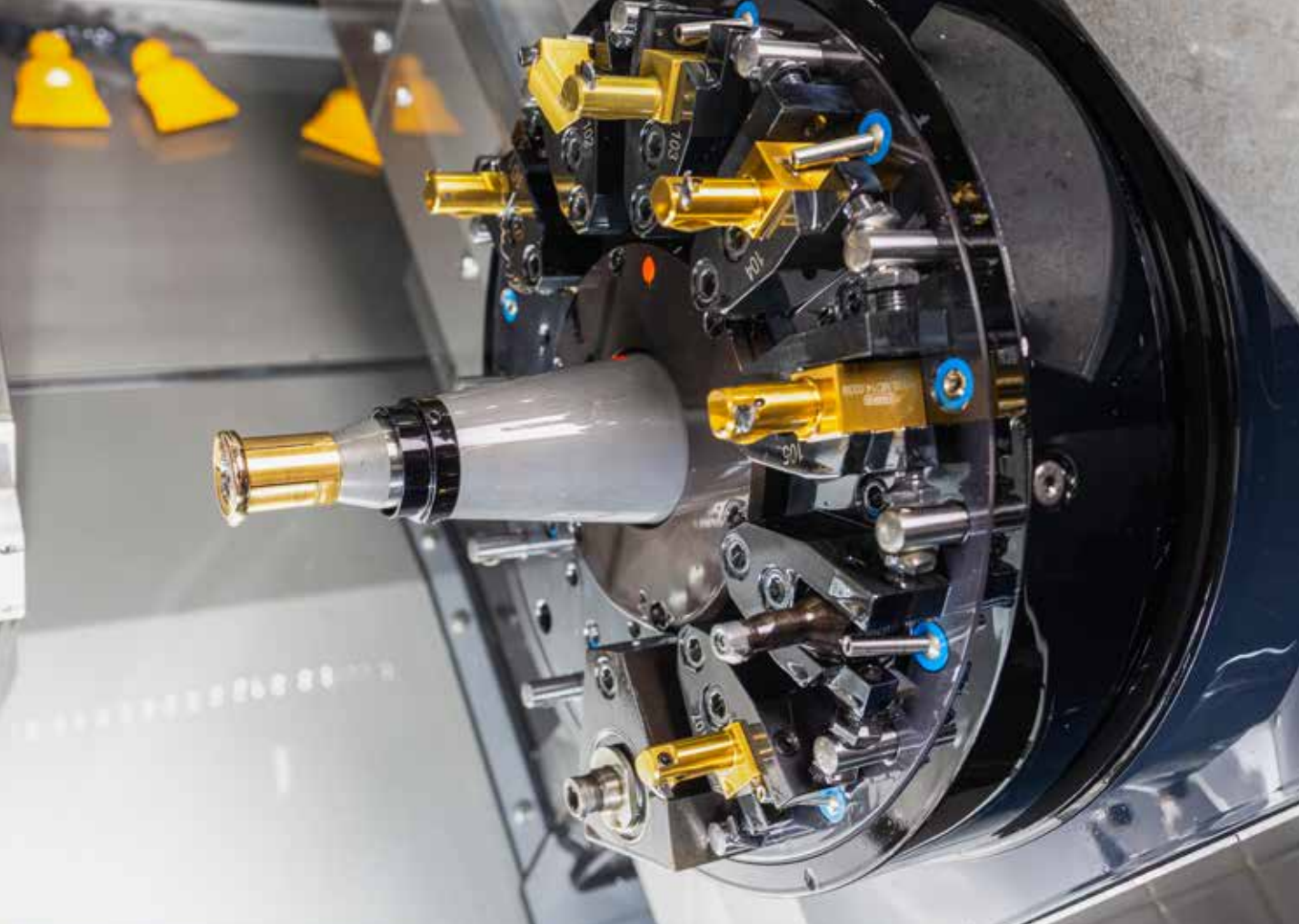

With its newly developed ring programme, HORN offers a range of diamond tools for pre- and finish-machining of rings, as well as the corresponding holder systems for external and internal machining.

distortion-free view into space. Diamond-tipped tools have been used in the manufacture of almost every visual aid, whether spectacles or contact lenses. Another application is in tool, model and mould making. Here, time-consuming and expensive polishing work can be saved. The list goes on; these tool systems are firmly established in the medical industry as well.

The quality of the tool cutting edge plays a decisive role in producing surfaces with a mirror finish. The precision of the insert is reflected in the surface being machined. The final grinding or polishing of the MCD cutting edge is a true art. Similar to the cutting of a diamond for jewellery, the finishing of an edge for high-polish machining is done by hand using grinding pliers. Air-bearing grinding tables with a solid granite top provide optimum conditions for grinding. A microscope with 200x magnification is used for visual inspection. Under this magnification, the cutting edge must be absolutely free of imperfections. The resulting cutting edge has a maximum radius of 0.0002 mm (0.000008"). HORN has developed a special machine for grinding MCD ball nose end mills for high-polish machining of flank faces, on which even the smallest radii can be reliably ground.

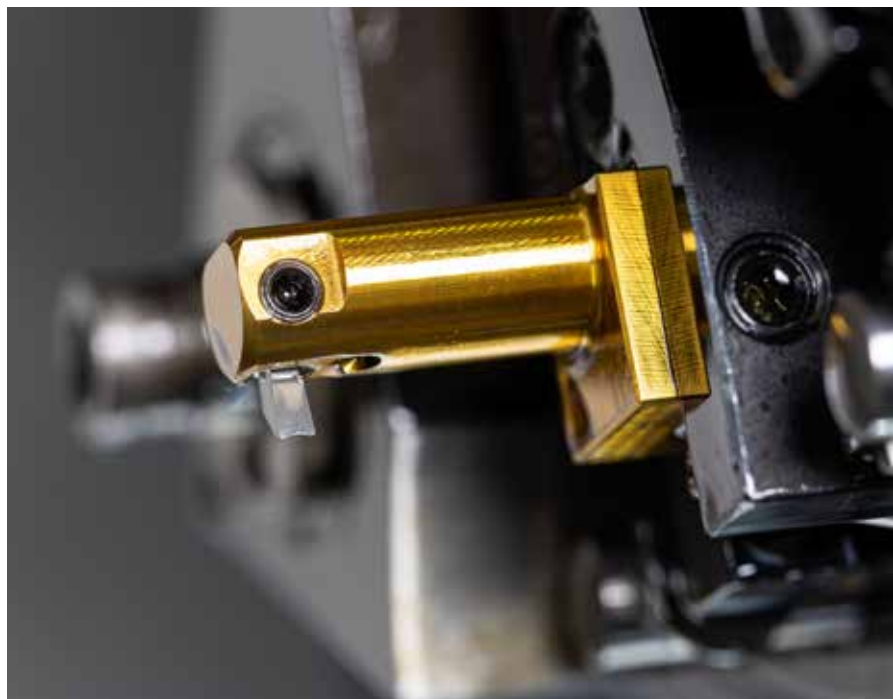

Users appreciate the user-friendly and precise HORN quick-change system, which minimises set-up times.

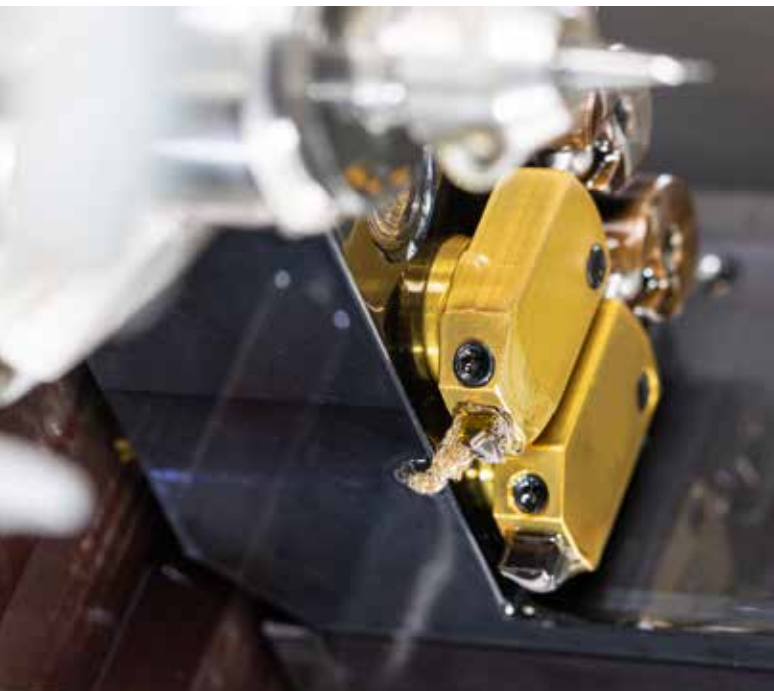

HORN uses high-purity MCC diamonds for its MCD tools.



The quality of the tool's cutting edge plays a crucial role in achieving surfaces with a mirror finish.

SYNTHETIC DIAMONDS

HORN uses high-purity MCC diamonds for its MCD tools. These monocrystalline stones are produced using the CVD process. Various gases, mainly methane, are used as a carbon source, which are deposited during the process and allow the diamonds to grow. The diamonds are characterised by their crystal clear to, depending on their thickness, slightly brownish colour. A major advantage of this process is the edge length of the stones that can be achieved. This means that even long tools with cutting edge lengths of 30 mm (1.181"), for example, can be realised. Previously, natural diamonds had to be used for such tools, which are difficult to obtain due to their high price and limited availability, and they contain natural inclusions. Subsequent polishing is eliminated thanks to the high-gloss finish. "The resulting surface is essentially perfect; we only need to slightly rework the transitions between the different tool passes. This depends on the specific ring profile," says Junge, adding: "Basically, we save several minutes of reworking per ring when using the MCD tools."

CONTINUOUS PROCESS CHAIN

Merkle supplies the rings it produces exclusively to B2B customers. They include large jewellery retail chains as well as small retailers and manufacturers. The team uses a special 3D ring configurator. The customer can configure the design, finish and any stone setting online. After the order is placed, the Merkle ERP system automatically generates the CNC program specifically for the ring, which the machine operator can call up directly at the machine. If a stone setting is required, the ring is moved to a milling machine, which cuts the holes for the desired setting. Stone setting is still manual work and is done in-house at Merkle. "With our process chain, we have a throughput time of just a few minutes for a standard ring. A goldsmith would need several hours for this," says Junge.

MERKLE SUPPLIES THE RINGS IT PRODUCES EXCLUSIVELY TO B2B CUSTOMERS.



A successful collaboration: HORN sales representatives Guido Dopatka, Thomas Junge and Aribert Schroth.

Merkle relies on Benzinger machines for its production. The GORing is a turning centre that has been specially developed for turning rings (wedding rings and other jewellery). High surface finishes are a top priority. The use of diamond tools, for example, enables brilliant surfaces to be achieved during turning. With the GORing R2, rings are completely turned from a blank. An automatic loading and unloading system, combined with a large number of turning tools, a rotary table (B-axis), milling spindles and many other features make the GORing R2 a productive and versatile turning centre for rings. With an optional Y-axis, the set-up time for diamond tools can be significantly reduced, as the tool centre height can be conveniently adjusted via the NC axis. This machine can be programmed and operated

very easily and intuitively using specially developed, parameterised CNC programs paired with dedicated user interfaces.

SUCCESSFUL COLLABORATION

The close collaboration between Merkle, HORN and Benzinger demonstrates how modern technology, precision craftsmanship and partnership-based quality complement each other. With clear processes, precise tool solutions and a deep understanding of the requirements of the market, the team succeeds in producing wedding rings of consistently high quality very efficiently. In this way, Merkle combines traditional values with innovative manufacturing expertise.



RING MANUFACTURER HCF MERKLE

The ring manufacturer HCF Merkle from Hamburg has been the benchmark for high-quality rings, precise production and reliable craftsmanship since 1853. As the oldest wedding ring manufacturer in Germany, the company combines traditional craftsmanship with modern production processes and a high degree of digitalisation, which enables consistently high quality and short delivery times. HCF Merkle manufactures both on behalf of its clients and under its own brand and sees itself as a reliable partner for jewellers and goldsmiths. Merkle supports its clients by ensuring efficiency, safety and on-time delivery. An important component is the in-house 3D configurator, which impresses customers with its flexibility, numerous design options and different implementation levels – from a consultation tool to a fully integrated shop solution for creating a customer's individual design. In addition to wedding rings, HCF Merkle has a strong presence in eternity rings and engagement rings. Experienced employees including four full-time gem setters, as well as CNC technology, laser engraving and digital processes, enable customised solutions, competitive prices and consistently high manufacturing quality.

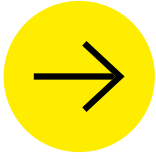

PRECIOUS METALS: BEYOND THE BLING

Implants, catalysts and wedding rings: things that could not be more different. However, they do have one thing in common: the use of precious metals. Gold and platinum are among the most technologically critical precious metals on our planet. They fulfil important functions in industrial processes, in electronics and in the jewellery industry. Despite their similar chemical stability, they differ significantly in terms of extraction volume, price and machinability.

Every year, mining companies produce around 3,660 tonnes of gold worldwide. Countries such as China, Australia, Russia, Canada and the USA are driving this production, ensuring a high level of availability. The global reserves of around 54,000 tonnes create additional security of supply and stabilise the market long term. Platinum is produced at a lower level: mines worldwide extract around 180 tonnes per year. South Africa supplies more than two thirds of this amount and therefore plays a key role in determining global supply. Russia and Zimbabwe supplement global production.

**MINES WORLDWIDE EXTRACT AROUND
180 TONNES OF PLATINUM PER YEAR.**



Every year, mining companies produce around 3,660 tonnes of gold worldwide. Platinum is mined in lower quantities.



Gold offers important advantages in technical applications.

RISING PRICES

In early March 2026, the price of gold was nearly 4,400 euros per troy ounce. Investors buy gold particularly in times of economic uncertainty, which often causes the price to rise. Platinum usually remains below the price of gold, even though it is much rarer. As industry drives most of the demand for platinum, its price fluctuates more strongly and closely follows the production cycles of the automotive and chemical industries.

Gold offers important advantages in technical applications. The electronics industry uses the precious metal because it offers reliable electrical conductivity and does not oxidise, even under demanding environmental conditions. Manufacturers use gold for contact surfaces, conductors and microelectronics to ensure high signal stability and long service life. The medical sector uses gold in dental alloys, implants and diagnostic systems due to its biocompatibility. In addition, the jewellery industry continues to regard gold as the most important precious metal due to its warm colour and stability.

INDUSTRIAL APPLICATIONS

Platinum primarily fulfils industrial functions. The automotive industry uses platinum in vehicle exhaust catalytic converters to chemically convert pollutants and reduce emissions. Chemical plants use platinum as a catalyst in processes for the production of silicones, pharmaceuticals, fertilisers and various polymers. Due to its high melting point and corrosion resistance, industry also uses platinum in thermocouples, laboratory equipment and high-temperature components. In the jewellery sector, platinum achieves lower sales volumes than gold, but customers appreciate its hardness, colour and abrasion resistance.

The machining properties of the two metals differ significantly. Gold is easy to machine, resulting in low cutting forces and minimal tool wear, while allowing the production of very high quality surface finishes with a mirror-like lustre. Goldsmiths, precision mechanics and electronics manufacturers benefit

from the metal's ductility, which enables tight tolerances and complex geometries. Platinum places significantly higher demands on machining. Its high strength and toughness increase cutting forces and place greater stress on tools. Machining generates high temperatures in the shear zone. For producing intricate shapes, companies require special tool geometries and optimised cutting parameters. These factors increase the effort and costs for producing platinum components.

Overall, gold and platinum fulfil clearly defined technical tasks. Gold supports high-quality electronics and precise applications thanks to its high malleability and conductivity. Platinum, on the other hand, is suitable for demanding industrial processes that generate high thermal and chemical loads. Due to their unique properties, both metals remain indispensable components of modern technologies.



Platinum primarily fulfils industrial tasks.



MASTERING BORING

INTERNAL MACHINING IN A NEW DIMENSION

HORN redefines internal machining with boring tools such as the Supermini. Maximum cutting performance thanks to HiPIMS coatings, process reliability through optimal chip control, a large selection of cutting inserts:

EXPLORE HORN.

Explore HORN grooving processes now



[horn-group.com](https://www.horn-group.com)