

BOHRUNG-DREHEN $\geq \varnothing 1,5$ mm

BORING and PROFILING



Schneidplatte Typ

105

Insert Type

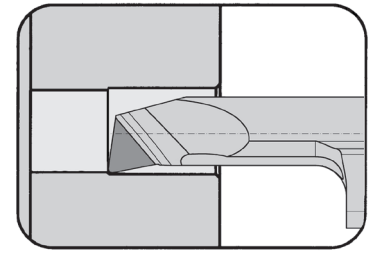

Bohrungs- \varnothing ab	Bore \varnothing from	1,5 mm
----------------------------	-------------------------	--------

CVD-Diamantbestückt
CVD Diamond tipped

für Klemmhalter
for Toolholder

Typ B105
Type BKT105
H105
HC105
VDI

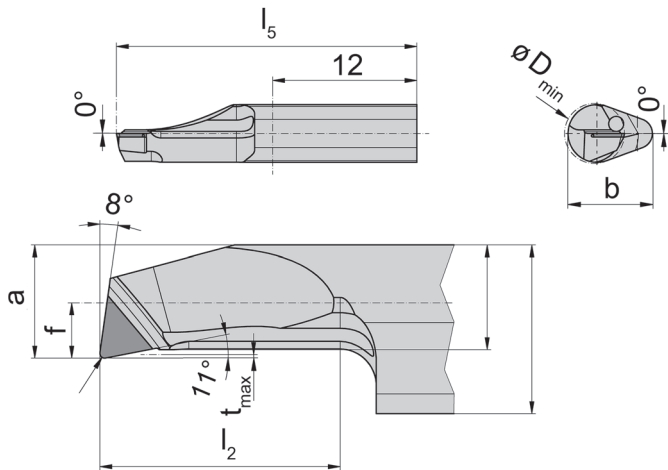

R = rechts wie gezeichnet
R = right hand version shown

Bestellnummer Part number	D_{min}	l_2	l_5	r	f	a	b	d	t_{max}	HD03
R105.1001.0.15.H0.C	1,5	6	25	0,10	1,5	1,3	5,9	1,05	0,15	▲
R105.1001.2.15.H0.C		12	30							▲
R105.1001.0.2.H0.C	2,0	6	25	0,15	1,4	1,8	5,9	1,55	0,15	▲
R105.1001.2.2.H0.C		12	30							▲
R105.1002.1.3.H0.C	3,0	10	25	0,20	1,4	2,7	5,9	2,45	0,15	▲
R105.1002.3.3.H0.C		20	35							▲
R105.1002.1.4.H0.C	4,0	10	25	0,20	1,9	3,7	6,4	3,35	0,15	▲
R105.1002.3.4.H0.C		20	35							▲
R105.1002.1.5.H0.C	5,0	10	25	0,20	2,3	4,7	7,0	4,35	0,15	▲
R105.1004.1.5.H0.C		10	25	0,40						▲
R105.1002.4.5.H0.C		25	40	0,20						▲
R105.1004.4.5.H0.C		25	40	0,40						▲

▲ ab Lager / on stock
Δ 4 Wochen / 4 weeks

Abmessungen in mm
Dimensions in mm

Weitere Abmessungen auf Anfrage
Further sizes upon request

BOHRUNG-DREHEN $\geq \varnothing 3 \text{ mm}$

BORING and PROFILING



Schneidplatte Typ

105

Insert Type

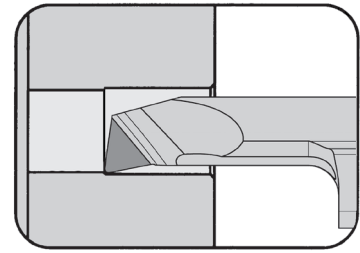

Bohrungs- \varnothing ab Bore \varnothing from 3 mm

PKD-bestückt
PCD tipped

für Klemmhalter
for Toolholder

Typ B105
Type BKT105
 H105
 HC105
 VDI

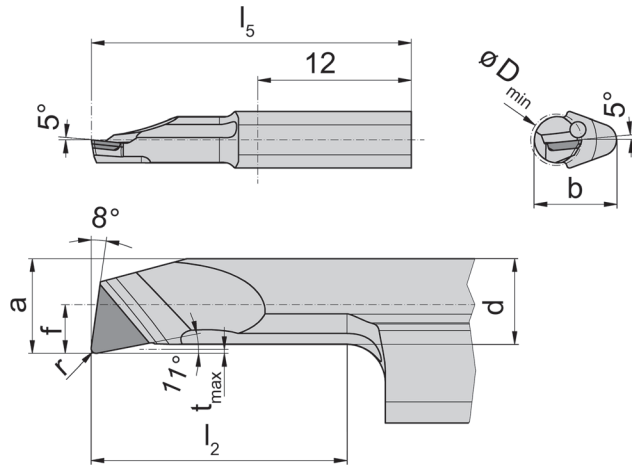

R = rechts wie gezeichnet
R = right hand version shown

Bestellnummer Part number	D_{min}	l_2	l_5	r	f	a	b	d	t_{max}	PD75
R105.1002.1.3.H5.P	3	10	25	0,2	1,4	2,7	5,9	2,45	0,15	▲
R105.1002.3.3.H5.P		20	35							▲
R105.1002.1.4.H5.P	4	10	25	0,2	1,9	3,7	6,4	3,35	0,15	▲
R105.1002.3.4.H5.P		20	35							▲
R105.1002.1.5.H5.P	5	10	25	0,2	2,3	4,7	7,0	4,35	0,15	▲
R105.1004.1.5.H5.P		10	25	0,4						▲
R105.1002.4.5.H5.P		25	40	0,2						▲
R105.1004.4.5.H5.P		25	40	0,4						▲

▲ ab Lager / on stock
 Δ 4 Wochen / 4 weeks

Abmessungen in mm
 Dimensions in mm

Weitere Abmessungen auf Anfrage
 Further sizes upon request

BOHRUNG-DREHEN $\geq \varnothing 4$ mm

BORING and PROFILING



Schneidplatte Typ

Insert Type

105

mit Spanformer
with chip former

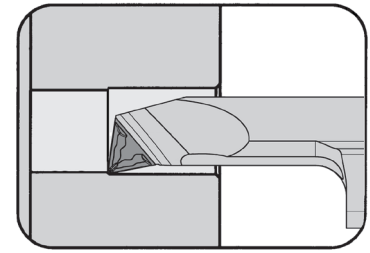

Bohrungs- \varnothing ab Bore \varnothing from 4 mm

PKD-bestückt
PCD tipped

für Klemmhalter
for Toolholder

Typ B105
Type BKT105
 H105
 HC105
 VDI

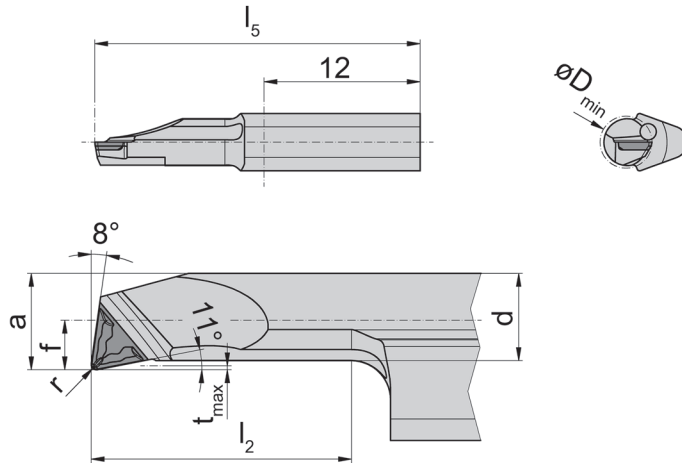

R = rechts wie gezeichnet
R = right hand version shown

Bestellnummer Part number	D_{min}	l_2	l_5	r	f	a	b	d	t_{max}	PD75
R105.1002.1.4.HF.P	4	10	25	0,2	1,9	3,7	6,4	3,35	0,15	▲
R105.1002.3.4.HF.P		20	35							▲
R105.1002.1.5.HF.P	5	10	25	0,2	2,3	4,7	7,0	4,35	0,15	▲
R105.1004.1.5.HF.P		10	25	0,4						▲
R105.1002.4.5.HF.P		25	40	0,2						▲
R105.1004.4.5.HF.P		25	40	0,4						▲

▲ ab Lager / on stock
Δ 4 Wochen / 4 weeks

Abmessungen in mm
Dimensions in mm

Weitere Abmessungen auf Anfrage
Further sizes upon request

BOHRUNG-DREHEN $\geq \varnothing 4$ mm

BORING and PROFILING



Schneidplatte Typ

105

Insert Type

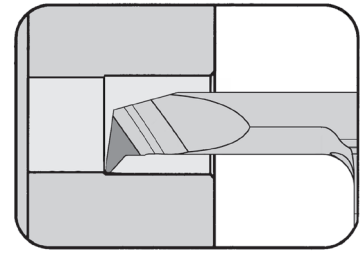

Bohrungs- \varnothing ab Bore \varnothing from 4 mm

PKD-bestückt
PCD tipped

für Klemmhalter
for Toolholder

Typ B105
Type BKT105
 H105
 HC105
 VDI

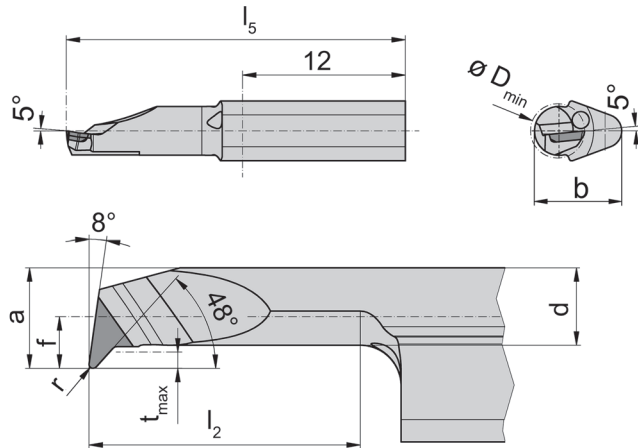

R = rechts wie gezeichnet
R = right hand version shown

Bestellnummer Part number	D_{min}	l_2	l_5	r	f	a	b	d	t_{max}	PD75
R105.4701.1.4.H5.P	4	10	25	0,15	1,9	3,7	6,4	2,85	0,6	▲
R105.4701.3.4.H5.P		20	35							▲
R105.4701.3.6.H5.P	6	20	35	0,15	3,3	5,7	7,0	4,85	0,6	▲
R105.4701.5.6.H5.P		30	45							▲

▲ ab Lager / on stock
 Δ 4 Wochen / 4 weeks

Abmessungen in mm
Dimensions in mm

Weitere Abmessungen auf Anfrage
Further sizes upon request

BOHRUNG-DREHEN $\geq \varnothing 5$ mm

BORING and PROFILING



Schneidplatte Typ

105

Insert Type

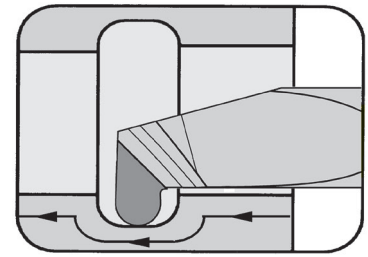

Bohrungs- \varnothing ab Vollradius	Bore \varnothing from Full radius	5,00 mm r 0,75 mm
--	--	----------------------

CVD-Diamantbestückt
CVD Diamond tipped

für Klemmhalter
for Toolholder

Typ B105
Type BKT105
H105
HC105
VDI

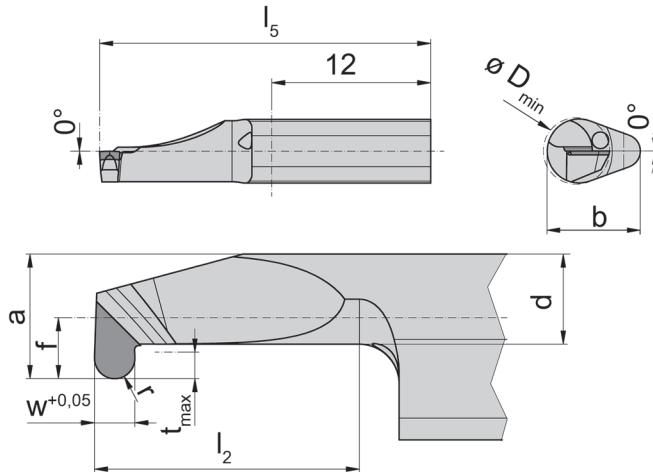

R = rechts wie gezeichnet
R = right hand version shown

Vollradius
Full radius

Bestellnummer Part number	D_{min}	l_2	l_5	r	f	a	b	d	w	t_{max}	HD03
R105.VR07.1.5.H0.C	5	10	25	0,75	2,3	4,7	7	3,4	1,5	1	▲

▲ ab Lager / on stock
Δ 4 Wochen / 4 weeks

Abmessungen in mm
Dimensions in mm

Weitere Abmessungen auf Anfrage
Further sizes upon request

BOHRUNG-DREHEN $\geq \varnothing 5$ mm

BORING and PROFILING



Schneidplatte Typ

105

Insert Type

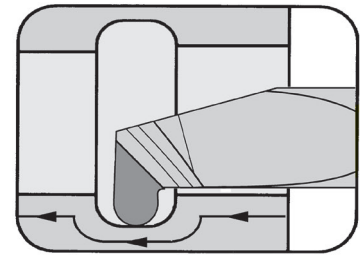

Bohrungs- \varnothing ab Vollradius	Bore \varnothing from Full radius	5,00 mm r 0,75 mm
--	--	----------------------

PKD-bestückt
PCD tipped

für Klemmhalter
for Toolholder

Typ B105
Type BKT105
H105
HC105
VDI

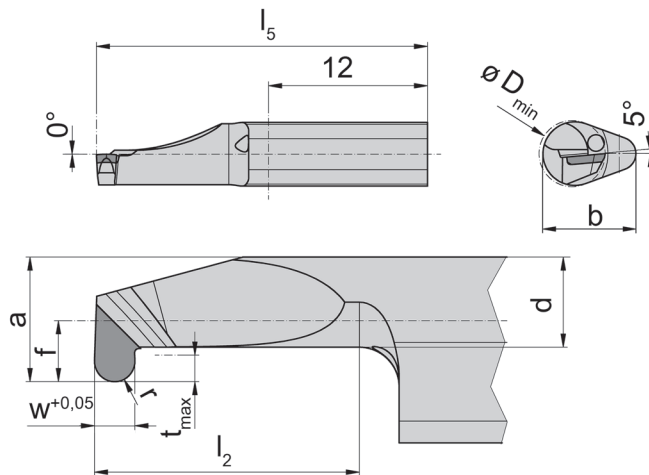

R = rechts wie gezeichnet
R = right hand version shown

Vollradius
Full radius

Bestellnummer Part number	D_{min}	l_2	l_5	r	f	a	b	d	w	t_{max}	PD75
R105.VR07.1.5.H5.P	5	10	25	0,75	2,3	4,7	7	3,4	1,5	1	▲

▲ ab Lager / on stock
Δ 4 Wochen / 4 weeks

Abmessungen in mm
Dimensions in mm

Weitere Abmessungen auf Anfrage
Further sizes upon request

BOHRUNG-DREHEN $\geq \varnothing 5 \text{ mm}$

BORING and PROFILING



Schneidplatte Typ

105

Insert Type

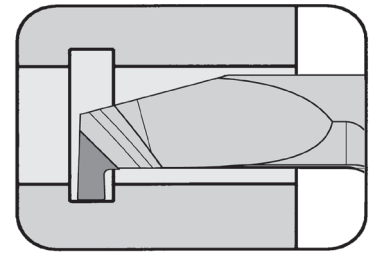

Bohrungs- \varnothing ab
Stechbreite bis

Bore \varnothing from
Width of groove up to

5 mm
1 mm

CVD-Diamantbestückt
CVD Diamond tipped

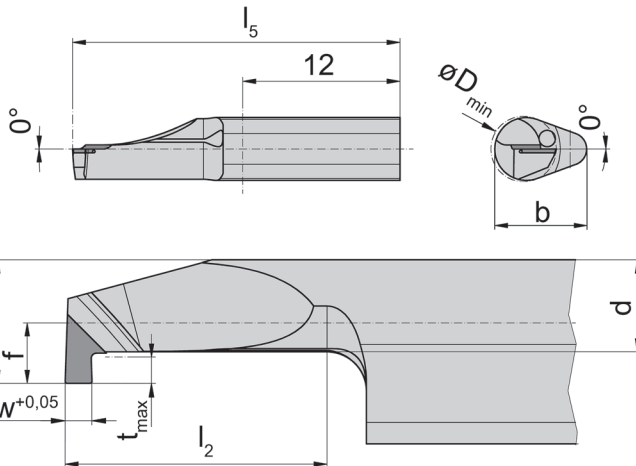

für Klemmhalter
for Toolholder

Typ B105
Type BKT105
H105
HC105
VDI

R = rechts wie gezeichnet
R = right hand version shown

Bestellnummer Part number	D_{min}	l_2	l_5	f	a	b	d	w	t_{max}	HD03
R105.0100.1.5.H0.C		10	25							▲
R105.0100.3.5.H0.C	5	20	35	2,3	4,7	7	3,5	1	1	▲
R105.0100.5.5.H0.C		30	45							▲

▲ ab Lager / on stock
Δ 4 Wochen / 4 weeks

Abmessungen in mm
Dimensions in mm

Weitere Abmessungen auf Anfrage
Further sizes upon request

BOHRUNG-DREHEN $\geq \varnothing 5$ mm

BORING and PROFILING



Schneidplatte Typ

105

Insert Type

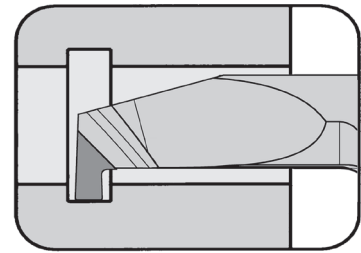

Bohrungs- \varnothing ab	Bore \varnothing from	5 mm
Stechtiefe bis	Depth of groove up to	1 mm

PKD-bestückt
PCD tipped

für Klemmhalter
for Toolholder

Typ B105
Type BKT105
H105
HC105
VDI

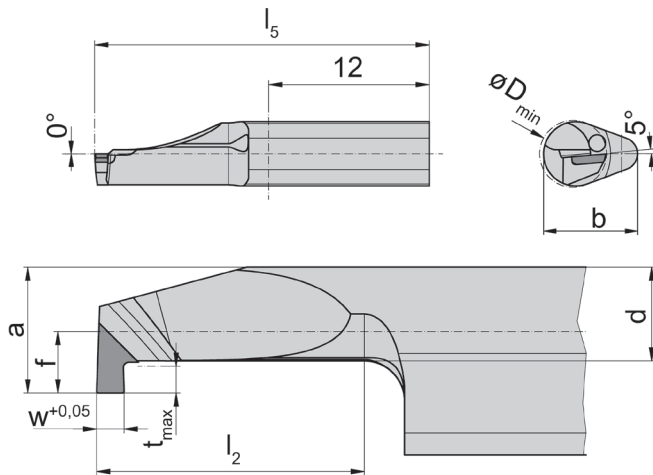

R = rechts wie gezeichnet
R = right hand version shown

Bestellnummer Part number	D_{min}	l_2	l_5	f	a	b	d	w	t_{max}	PD75
R105.0100.1.5.H5.P		10	25							▲
R105.0100.3.5.H5.P	5	20	35	2,3	4,7	7	3,5	1	1	▲
R105.0100.5.5.H5.P		30	45							▲

▲ ab Lager / on stock
Δ 4 Wochen / 4 weeks

Abmessungen in mm
Dimensions in mm

Weitere Abmessungen auf Anfrage
Further sizes upon request