

## Kit Components

3E<sup>TECH+</sup> | Insert Form 101 | Diameter Range: 10.00 mm - 30.00 mm

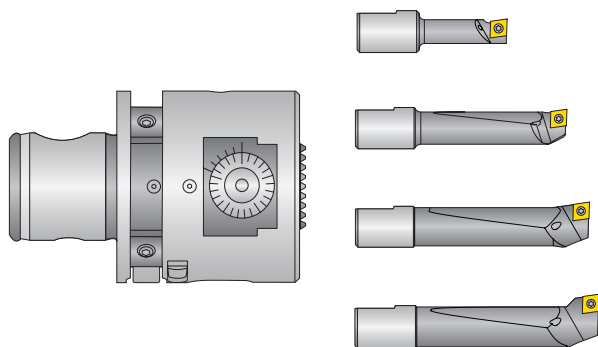

Diameter Range: 10.00 mm - 30.00 mm

Kit Components					
	Boring Head	Boring Bar Range	Boring Bars	Service Keys	Kit No.
m	536002	10.00 - 15.00	218048	115575 (s2.5)	103046
		15.00 - 20.00	081041	215403 (s4)	
		20.00 - 25.00	081042	115590 (T8)	
		25.00 - 30.00	081043		

NOTE: Balancing elements and inserts sold separately

NOTE: 3E<sup>TECH+</sup> digital readout module and charging station sold separately



### 3E<sup>TECH+</sup> Digital Readout Module

Part No.	Charging Unit*
536015	536016

NOTE: WEEE-Reg.-Nr. DE 15820388

\*Charging unit sold separately



NOTE: 3E<sup>TECH+</sup> adjustment accuracy of 0.001 mm on diameter

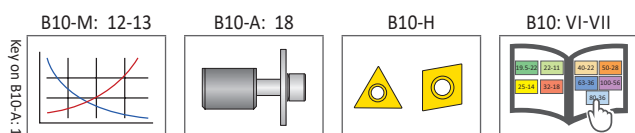

m = Metric (mm)

Inserts sold separately

**IMPORTANT:** Max spindle speed refers to maximum possible speed for an individual boring head and is not a recommended parameter. Refer to page B10-M: 12 for recommended application-specific parameters. Factory technical assistance is available for your specific applications through our Application Engineering department.  
email: [engineering.eu@alliedmachine.com](mailto:engineering.eu@alliedmachine.com)

## Kit Components

3E<sup>TECH+</sup> | Insert Form 20 | Diameter Range: 10.00 mm - 30.00 mm

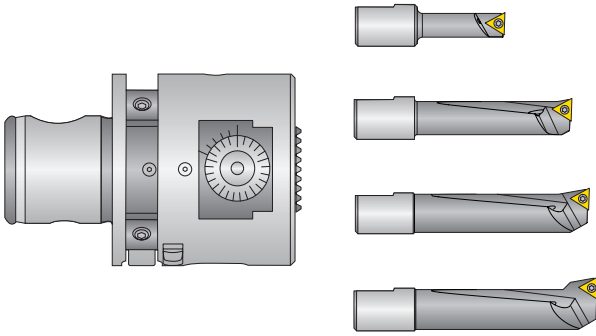

Diameter Range: 10.00 mm - 30.00 mm

Kit Components					
	Boring Head	Boring Bar Range	Boring Bars	Service Keys	Kit No.
m	536002	10.00 - 15.00	218059	115575 (s2.5)	103045
		15.00 - 20.00	081045	215403 (s4)	
		20.00 - 25.00	081046	115591 (T7)	
		25.00 - 30.00	081047		

NOTE: Balancing elements and inserts sold separately

NOTE: 3E<sup>TECH+</sup> digital readout module and charging station sold separately



### 3E<sup>TECH+</sup> Digital Readout Module

Part No.	Charging Unit*
536015	536016

NOTE: WEEE-Reg.-Nr. DE 15820388

\*Charging unit sold separately



NOTE: 3E<sup>TECH+</sup> adjustment accuracy of 0.001 mm on diameter

Key on B10-A-1:

B10-M: 12-13

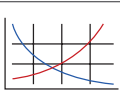

B10-A: 18

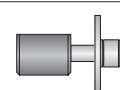

B10-H

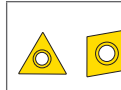

B10: VI-VII



m = Metric (mm)

Inserts sold separately

**IMPORTANT:** Max spindle speed refers to maximum possible speed for an individual boring head and is not a recommended parameter. Refer to page B10-M: 12 for recommended application-specific parameters. Factory technical assistance is available for your specific applications through our Application Engineering department.  
 email: [engineering.eu@alliedmachine.com](mailto:engineering.eu@alliedmachine.com)

## Kit Components

3E<sup>TECH+</sup> | Insert Form 101 | Diameter Range: 10.00 mm - 102.00 mm

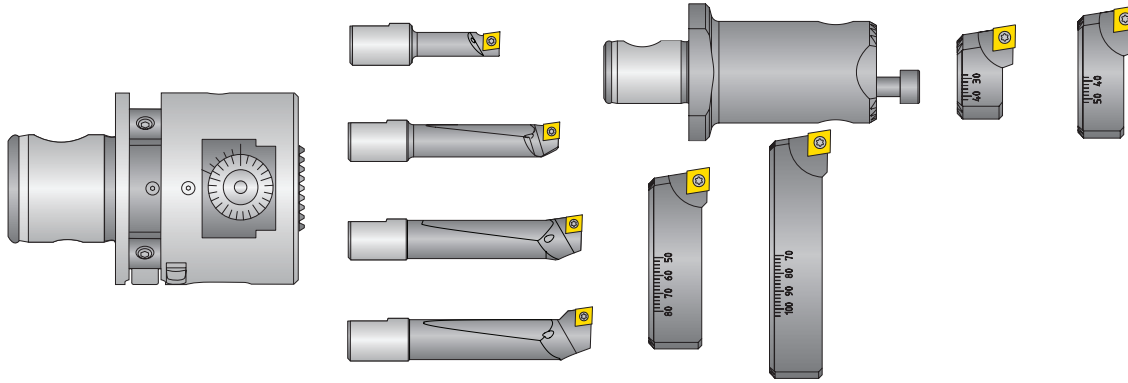

Diameter Range: 10.00 mm - 102.00 mm

### Kit Components

Boring Head	Boring Bars		Serrated Tool Body & Insert Holders			Insert Holders for Boring Head			Service Keys	Kit No.
	Boring Bar Range	Part No.	Serrated Tool Body	Insert Holder Range	Part No.	Insert Holder Range	Part No.	Clamping Piece		
m	10.00 - 15.00	218048	236021	29.00 - 41.00	236023	52.00 - 77.00	236027	236020	115575 (s2.5)	103048
	15.00 - 20.00	081041		40.00 - 53.00	236025	76.00 - 102.00	236029		215403 (s4)	
	20.00 - 25.00	081042							215521 (s5)	
	25.00 - 30.00	081043							115590 (T8)	

NOTE: Balancing elements and inserts sold separately  
 NOTE: 3E<sup>TECH+</sup> digital readout module and charging station sold separately



### 3E<sup>TECH+</sup> Digital Readout Module

Part No.	Charging Unit*
536015	536016

NOTE: WEEE-Reg.-Nr. DE 15820388  
 \*Charging unit sold separately



NOTE: 3E<sup>TECH+</sup> adjustment accuracy of 0.001 mm on diameter

Key on B10-A-1

B10-M: 12-13 	B10-A: 18 	B10-H 	B10: VI-VII 
------------------	---------------	-----------	-----------------

m = Metric (mm)

Inserts sold separately

**IMPORTANT:** Max spindle speed refers to maximum possible speed for an individual boring head and is not a recommended parameter. Refer to page B10-M: 12 for recommended application-specific parameters. Factory technical assistance is available for your specific applications through our Application Engineering department.  
 email: [engineering.eu@alliedmachine.com](mailto:engineering.eu@alliedmachine.com)

## Kit Components

3E<sup>TECH+</sup> | Insert Form 20 | Diameter Range: 10.00 mm - 102.00 mm

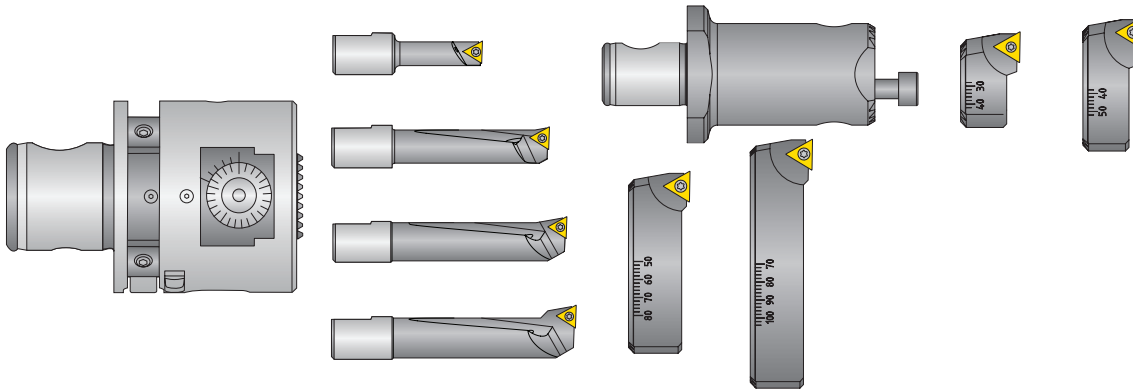

Diameter Range: 10.00 mm - 102.00 mm

Kit Components										
Boring Head	Boring Bars		Serrated Tool Body & Insert Holders			Insert Holders for Boring Head			Service Keys	Kit No.
	Boring Bar Range	Part No.	Serrated Tool Body	Insert Holder Range	Part No.	Insert Holder Range	Part No.	Clamping Piece		
m	10.00 - 15.00	218059	236021	29.00 - 41.00	236026	52.00 - 77.00	236022	236020	115575 (s2.5)	103047
	15.00 - 20.00	081045		40.00 - 53.00	236028	76.00 - 102.00	236024		215403 (s4)	
	20.00 - 25.00	081046					215521 (s5)			
	25.00 - 30.00	081047					115591 (T7)			

NOTE: Balancing elements and inserts sold separately

NOTE: 3E<sup>TECH+</sup> digital readout module and charging station sold separately



### 3E<sup>TECH+</sup> Digital Readout Module

Part No.	Charging Unit*
536015	536016

NOTE: WEEE-Reg.-Nr. DE 15820388

\*Charging unit sold separately



NOTE: 3E<sup>TECH+</sup> adjustment accuracy of 0.001 mm on diameter

Key on B10-A-1

B10-M: 12-13

B10-A: 18

B10-H

B10: VI-VII

m = Metric (mm)

Inserts sold separately

**IMPORTANT:** Max spindle speed refers to maximum possible speed for an individual boring head and is not a recommended parameter. Refer to page B10-M: 12 for recommended application-specific parameters. Factory technical assistance is available for your specific applications through our Application Engineering department.  
 email: [engineering.eu@alliedmachine.com](mailto:engineering.eu@alliedmachine.com)

## Kit Components

Non-Digital | Insert Form 101 | Diameter Range: 10.00 mm - 30.00 mm

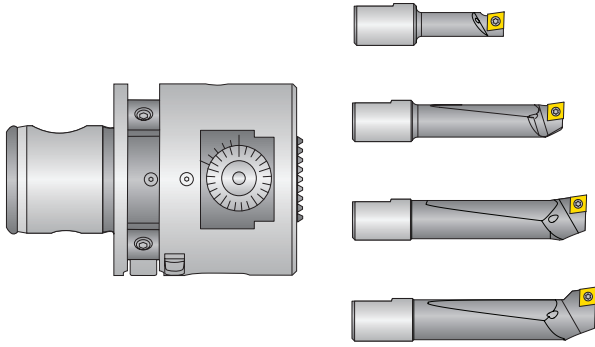

Diameter Range: 10.00 mm - 30.00 mm

Kit Components					
	Boring Head	Boring Bar Range	Boring Bars	Service Keys	Kit No.
m	536001	10.00 - 15.00	218048	115575 (s2.5)	103050
		15.00 - 20.00	081041	215403 (s4)	
		20.00 - 25.00	081042	115590 (T8)	
		25.00 - 30.00	081043		

NOTE: Balancing elements and inserts sold separately

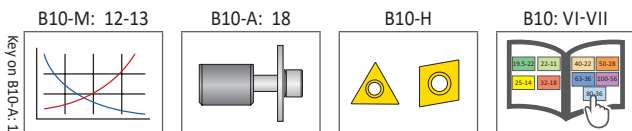

m = Metric (mm)

Inserts sold separately

**IMPORTANT:** Max spindle speed refers to maximum possible speed for an individual boring head and is not a recommended parameter. Refer to page B10-M: 12 for recommended application-specific parameters. Factory technical assistance is available for your specific applications through our Application Engineering department.  
 email: [engineering.eu@alliedmachine.com](mailto:engineering.eu@alliedmachine.com)

## Kit Components

Non-Digital | Insert Form 20 | Diameter Range: 10.00 mm - 30.00 mm

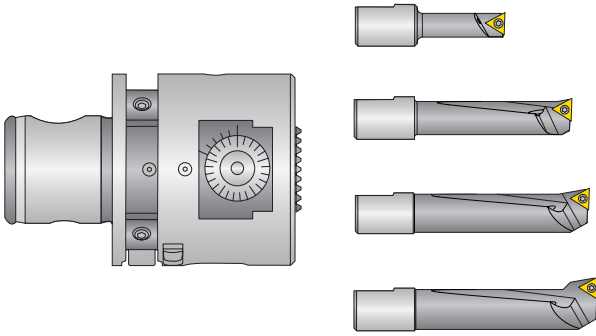

Diameter Range: 10.00 mm - 30.00 mm

Kit Components					
	Boring Head	Boring Bar Range	Boring Bars	Service Keys	Kit No.
m	536001	10.00 - 15.00	218059	115575 (s2.5)	103049
		15.00 - 20.00	081045	215403 (s4)	
		20.00 - 25.00	081046	115591 (T7)	
		25.00 - 30.00	081047		

**NOTE:** Balancing elements and inserts sold separately



B10-M: 12-13

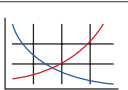

Key on B10-A: 1

B10-A: 18

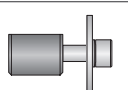

B10-H

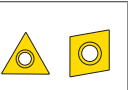

B10: VI-VII

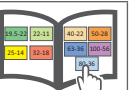

m = Metric (mm)  
Inserts sold separately

**IMPORTANT:** Max spindle speed refers to maximum possible speed for an individual boring head and is not a recommended parameter. Refer to page B10-M: 12 for recommended application-specific parameters. Factory technical assistance is available for your specific applications through our Application Engineering department.  
email: [engineering.eu@alliedmachine.com](mailto:engineering.eu@alliedmachine.com)

## Kit Components

Non-Digital | Insert Form 101 | Diameter Range: 10.00 mm - 102.00 mm

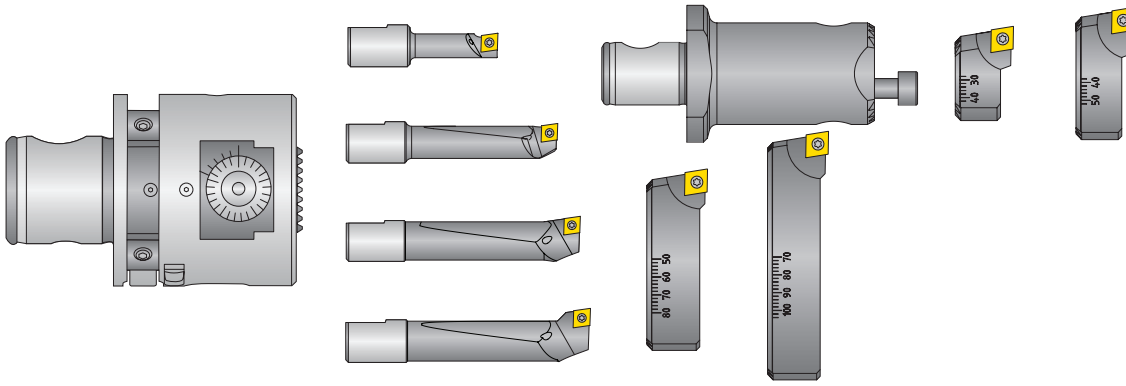

Diameter Range: 10.00 mm - 102.00 mm

Kit Components										
Boring Head	Boring Bars		Serrated Tool Body & Insert Holders			Insert Holders for Boring Head			Service Keys	Kit No.
	Boring Bar Range	Part No.	Serrated Tool Body	Insert Holder Range	Part No.	Insert Holder Range	Part No.	Clamping Piece		
m	10.00 - 15.00	218048	236021	29.00 - 41.00	236023	52.00 - 77.00	236027	236020	115575 (s2.5)	103052
	15.00 - 20.00	081041		40.00 - 53.00	236025	76.00 - 102.00	236029		215403 (s4)	
	20.00 - 25.00	081042							215521 (s5)	
	25.00 - 30.00	081043							115590 (T8)	

NOTE: Balancing elements and inserts sold separately



Key on B10-A-1

B10-M: 12-13

B10-A: 18

B10-H

B10: VI-VII

m = Metric (mm)  
Inserts sold separately

**IMPORTANT:** Max spindle speed refers to maximum possible speed for an individual boring head and is not a recommended parameter. Refer to page B10-M: 12 for recommended application-specific parameters. Factory technical assistance is available for your specific applications through our Application Engineering department.  
email: [engineering.eu@alliedmachine.com](mailto:engineering.eu@alliedmachine.com)

## Kit Components

Non-Digital | Insert Form 20 | Diameter Range: 10.00 mm - 102.00 mm

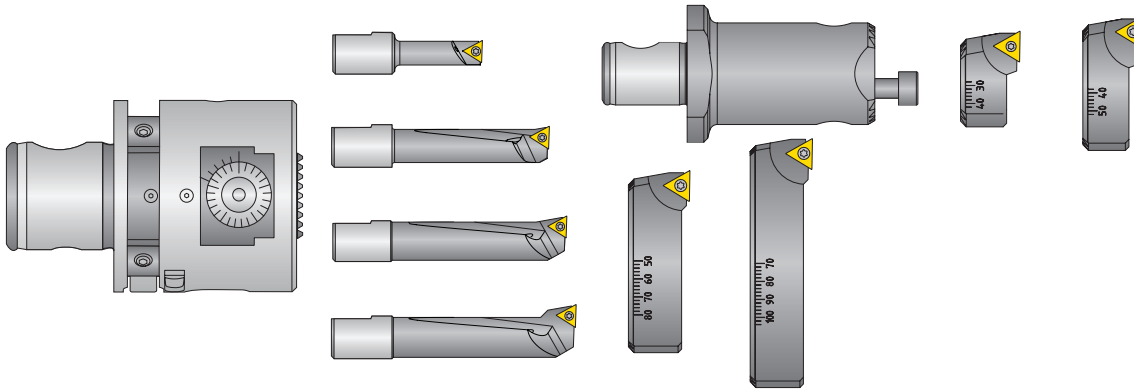

Diameter Range: 10.00 mm - 102.00 mm

Kit Components											
Boring Head	Boring Bars		Serrated Tool Body & Insert Holders			Insert Holders for Boring Head			Service Keys	Kit No.	
	Boring Bar Range	Part No.	Serrated Tool Body	Insert Holder Range	Part No.	Insert Holder Range	Part No.	Clamping Piece			
Ⓜ	10.00 - 15.00	218059	236021	29.00 - 41.00	236022	52.00 - 77.00	236026	236020	115575 (s2.5)	103051	
	15.00 - 20.00	081045		40.00 - 53.00		236024			76.00 - 102.00		236028
	20.00 - 25.00	081046						215521 (s5)			
	25.00 - 30.00	081047						115591 (T7)			

NOTE: Balancing elements and inserts sold separately



B10-M: 12-13

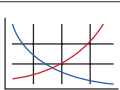

Key on B10-A: 1

B10-A: 18

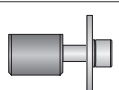

B10-H

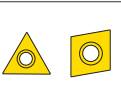

B10: VI-VII

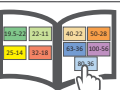

Ⓜ = Metric (mm)

Inserts sold separately

**IMPORTANT:** Max spindle speed refers to maximum possible speed for an individual boring head and is not a recommended parameter. Refer to page B10-M: 12 for recommended application-specific parameters. Factory technical assistance is available for your specific applications through our Application Engineering department.  
 email: [engineering.eu@alliedmachine.com](mailto:engineering.eu@alliedmachine.com)