

Modulare Aggregatetechnik

**TSUGAMI**

**WF**  
&

ph HORN ph



**Katalog  
TS-02**



# WFB-Adapterpool

Indications for the customer

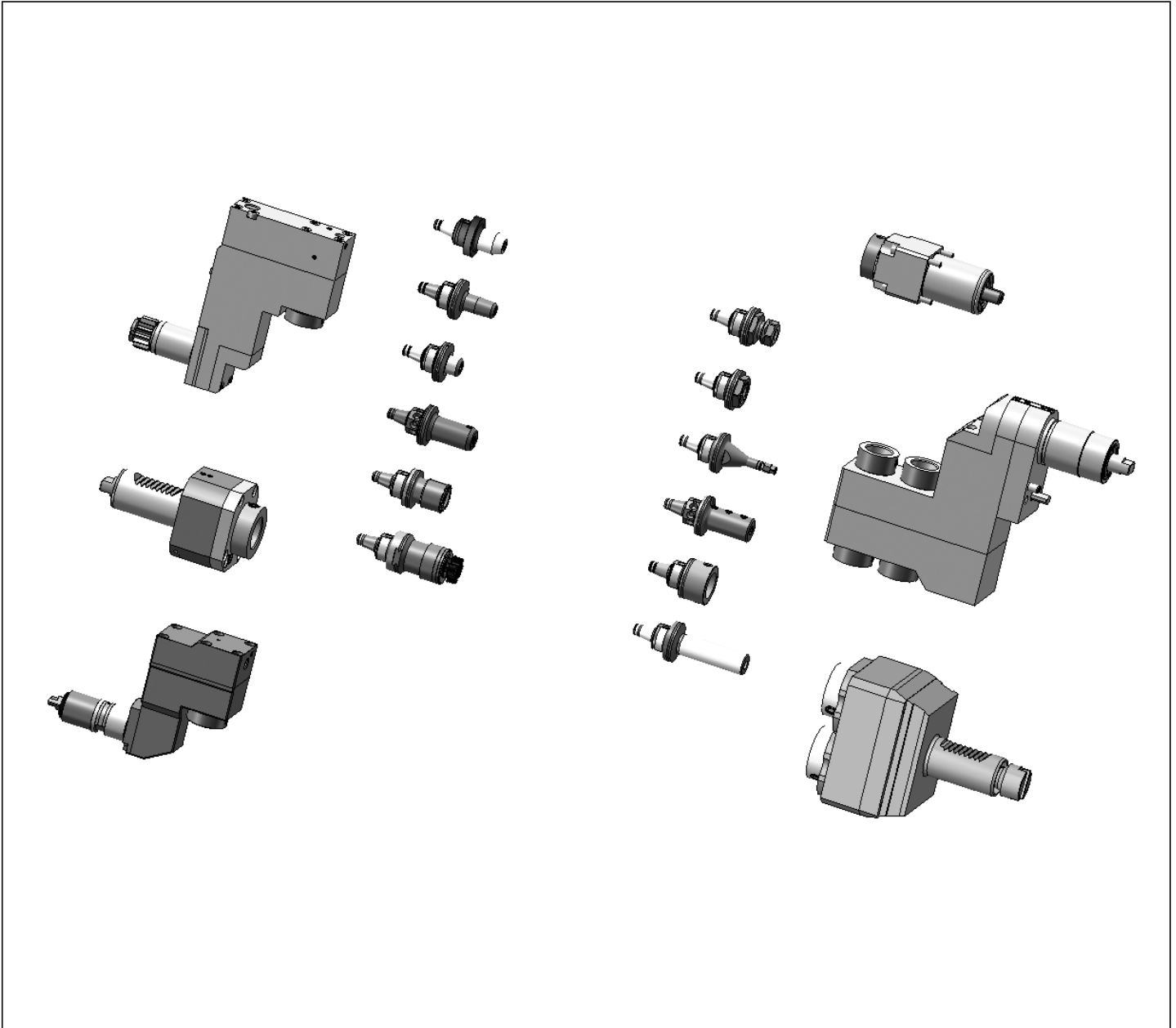

Mit den Werkzeughaltern von W&F in statischer oder angetriebener Ausführung und dem WFB-Adaptersystem haben Sie die einzigartige Möglichkeit, für sämtliche Hersteller egal ob im Kurzdrehen, Langdrehen oder Mehrspindel-drehen ein durchgängiges modulares Werkzeug-system einzusetzen.

The W&F tool holders are in static or driven performance and beyond that, the WFB-adapter system offers you an unique option to use it for every machine manufacturer whether you are manufacturer producing with swiss type lathes, standard turning machines or multispindle turning machines, WFB is suitable.

# Tsugami

## Axial Bohr- und Fräskopf

Axial drilling and milling head

Outil de perçage et de fraisage axiale

WG 35

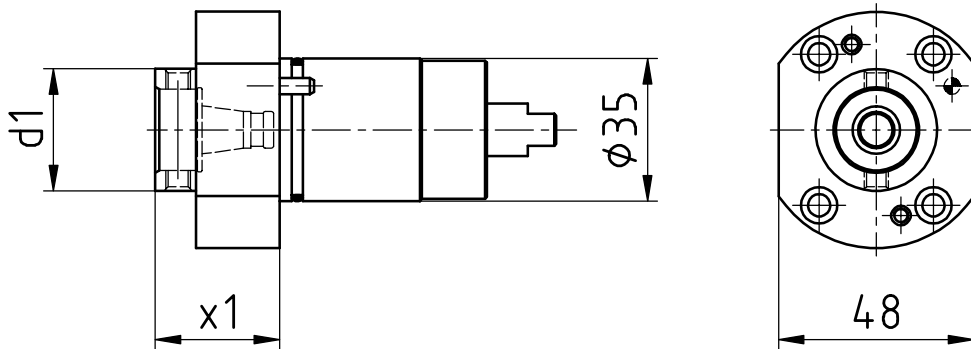
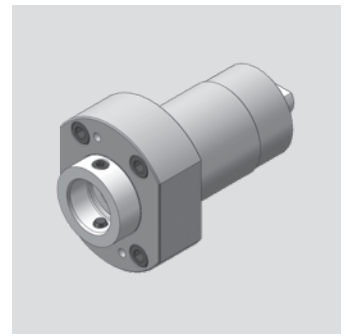

[mm]	[mm]	Spindle Broche <b>Spindel</b>	[Nm] <b>T max</b>	[rpm] <b>n max</b>	<b>i</b>	Outside cooling Lubrificat. ext. <b>Aussenkühlung</b>	Internal cooling Lubrificat. cent. <b>Innenkühlung</b>	[bar] <b>p</b>	Order no. N° de Code <b>Bestellnummer</b>
d1	x1								
30	30,5	WFB 20-12	10	8.000	1:1				MPU.Z35.B20.AA0.TS

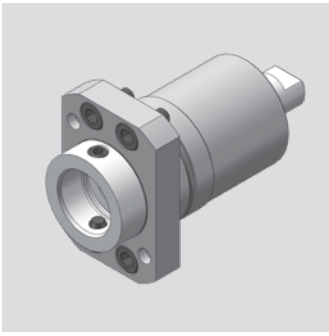

# Tsugami

## Axial Bohr- und Fräskopf

Axial drilling and milling head

Outil de perçage et de fraisage axiale

**WG 35**

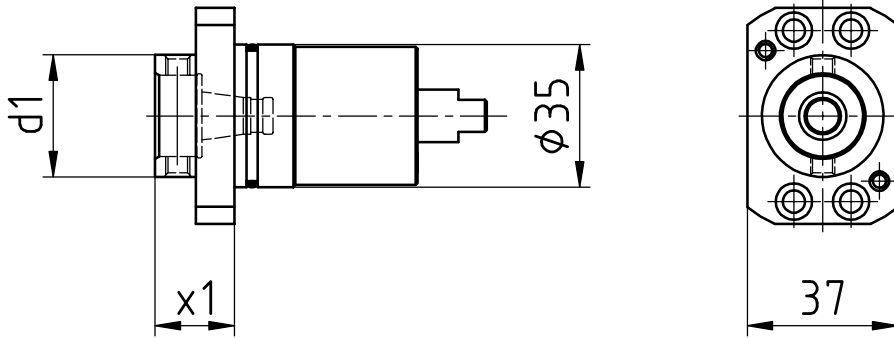

[mm]	[mm]	Spindle Broche <b>Spindel</b>	[Nm] <b>T max</b>	[rpm] <b>n max</b>	<b>i</b>	Outside cooling Lubrificat. ext. <b>Aussenkühlung</b>	Internal cooling Lubrificat. cent. <b>Innenkühlung</b>	[bar] <b>p</b>	Order no. N° de Code <b>Bestellnummer</b>
<b>d1</b>	<b>x1</b>								
30	19,5	WFB 20-12	10	8.000	1:1				MPU.Z35.B20.AA0.TSR

# Tsugami

## Radial Bohr- und Fräskopf

Radial drilling and milling head

Outil de perçage et de fraisage radiale

WG 35

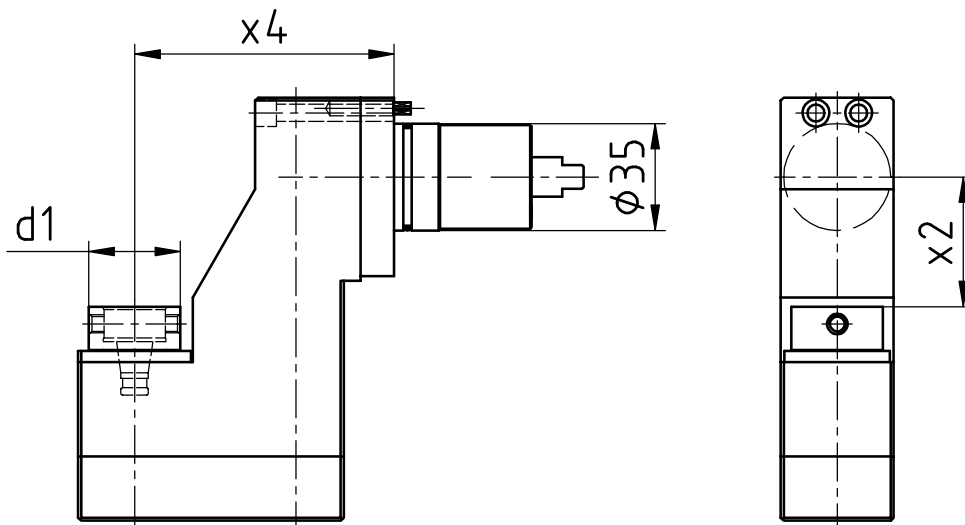
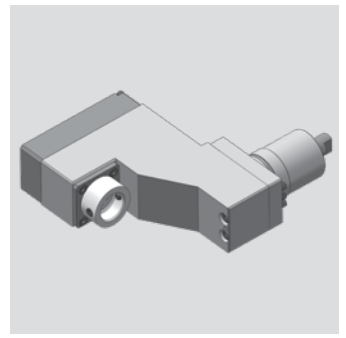

[mm]	[mm]	[mm]	Spindle Broche Spindel	[Nm] T max	[rpm] n max	i	Outside cooling Lubrificat. ext. Aussenkühlung	Internal cooling Lubrificat. cent. Innenkühlung	[bar] p	Order no. N° de Code Bestellnummer
d1	x2	x4	WFB 20-12	10	8.000	1:1				MPU.Z35.B20.RA0.TS

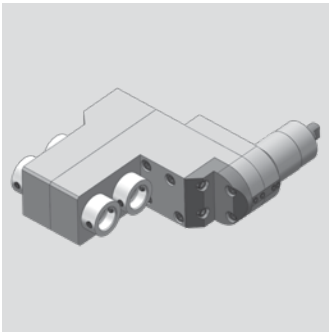

# Tsugami

**Radial Bohr- und Fräskopf**  
 Radial drilling and milling head  
 Outil de perçage et de fraisage radiale

**WG 35**

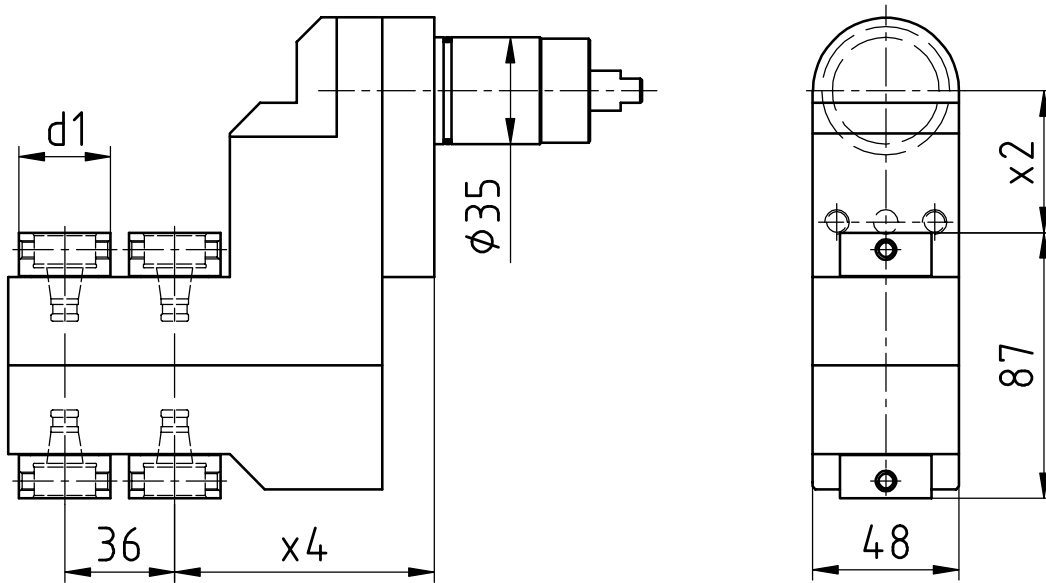

[mm]	[mm]	[mm]	Spindle Broche	[Nm]	[rpm]	Outside cooling Lubrificat. ext.	Internal cooling Lubrificat. cent.	[bar]	Order no. N° de Code
<b>d1</b>	<b>x2</b>	<b>x4</b>	<b>Spindel</b>	<b>T max</b>	<b>n max</b>	<b>Aussenkühlung</b>	<b>Innenkühlung</b>	<b>p</b>	<b>Bestellnummer</b>
30	46,5	85	WFB 20-12	3	8.000	1:1			MPU.Z35.B20.4A0.TS

# Tsugami

## Radial Bohr- und Fräskopf

Radial drilling and milling head

Outil de perçage et de fraisage radiale

WG 35

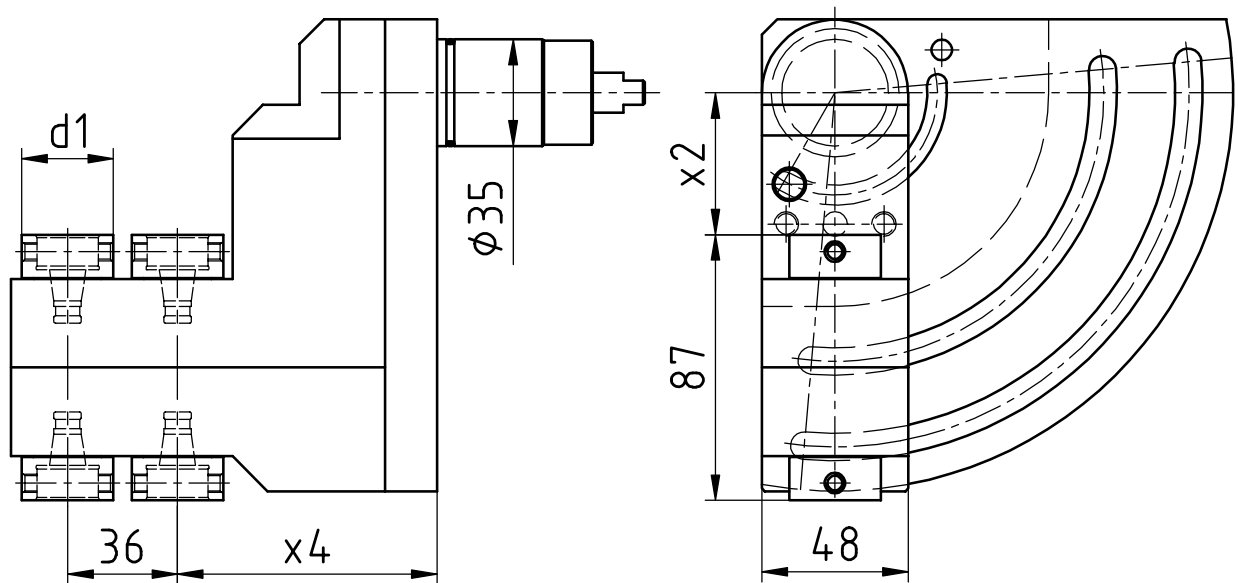
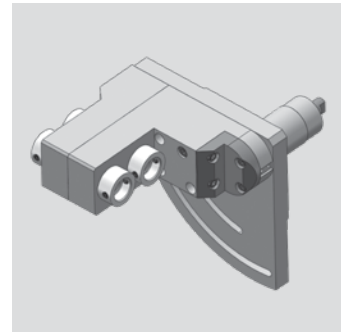

[mm]	[mm]	[mm]	Spindle Broche Spindel	[Nm] T max	[rpm] n max		Outside cooling Lubrificat. ext. Aussenkühlung	Internal cooling Lubrificat. cent. Innenkühlung	[bar] p	Order no. N° de Code Bestellnummer
d1	x2	x4			i					
30	46,5	85	WFB 20-12	3	8.000	1:1				MPU.Z35.B20.4S0.TS

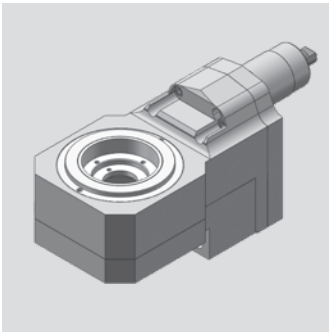

# Tsugami

**Gewindewirbelapparat**  
 Thread whirling unit  
 Unité de tourbillonnement

**WG 35**

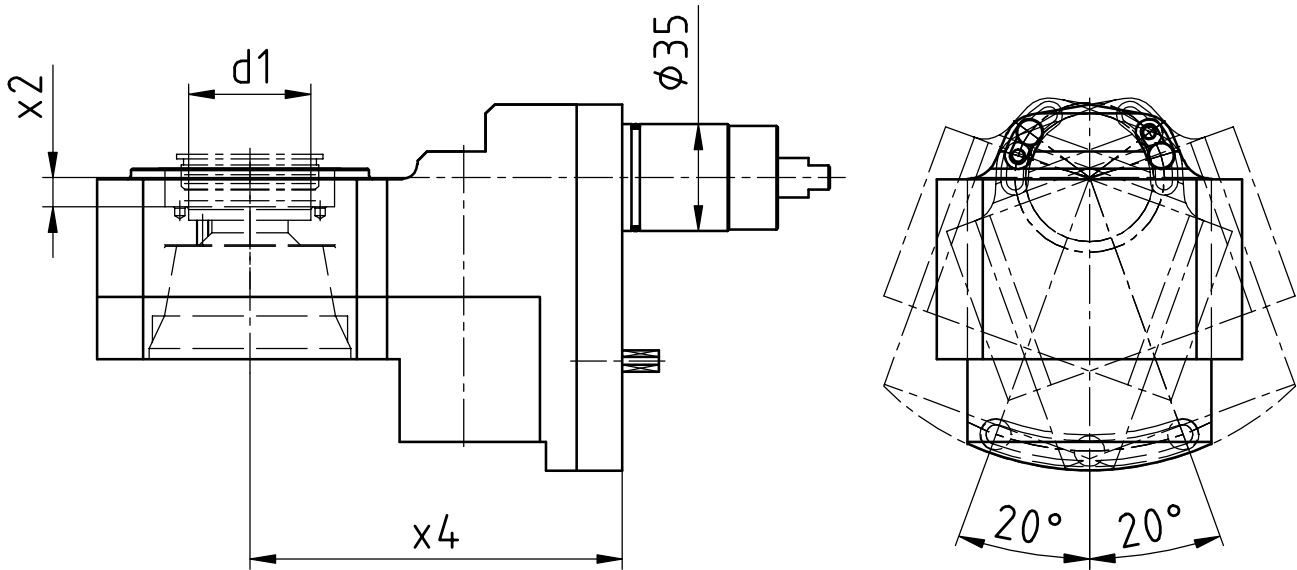

[mm]	[mm]	[mm]	Spindle Broche Spindel	[Nm]	[rpm]		Outside cooling Lubrificat. ext. Aussenkühlung	Internal cooling Lubrificat. cent. Innenkühlung	[bar]	Order no. N° de Code Bestellnummer
d1	x2	x4		T max	n max	i			p	
40	9,5	122	MONO	16	6.932	1,154:1 x				MPU.Z35.0800.TS



# Tsugami

## Gewindewirbelapparat modular

Thread whirling unit

Unité de tourbillonnement

WG 35

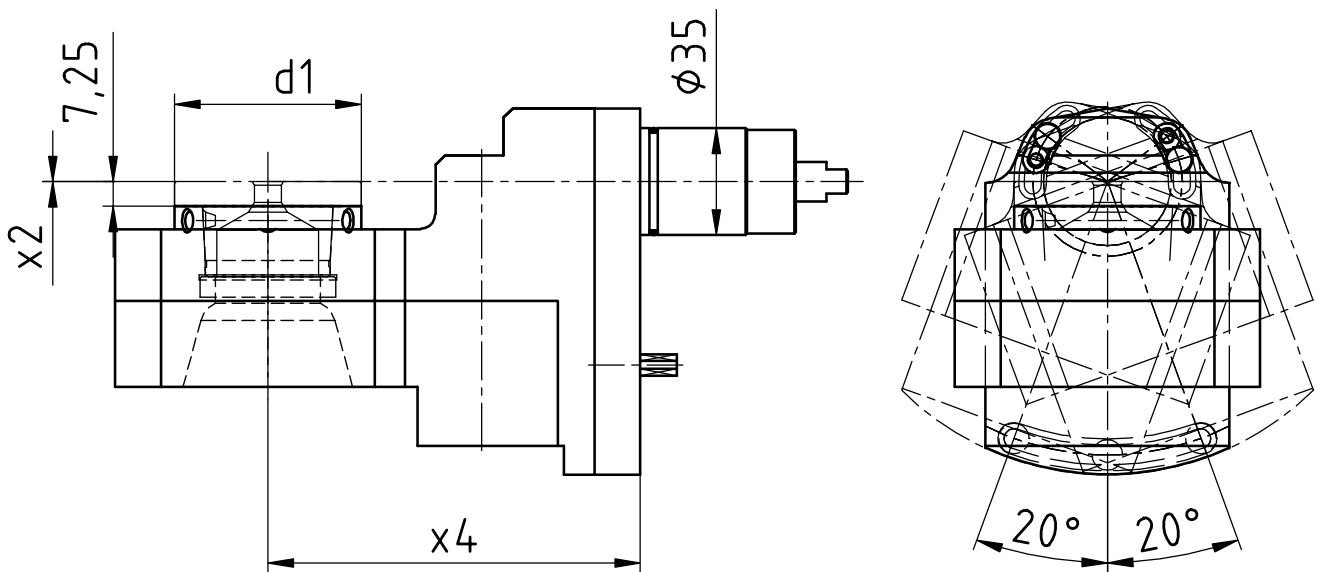
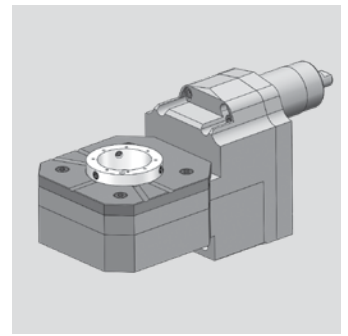

[mm]	[mm]	[mm]	Spindle Broche Spindel	[Nm]	[rpm]		Outside cooling Lubrificat. ext. Aussenkühlung	Internal cooling Lubrificat. cent. Innenkühlung	[bar]	Order no. N° de Code Bestellnummer
d1	x2	x4		T max	n max	i			p	
54	0	122	WFW 50	16	6.932	1,154:1	x			MPU.Z35.M0800.TS

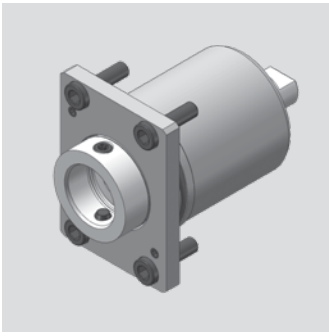

# Tsugami

## Axial Bohr- und Fräskopf

Axial drilling and milling head

Outil de perçage et de fraisage axiale

WG 35

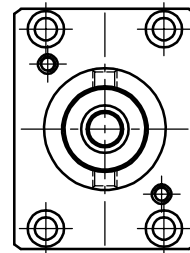
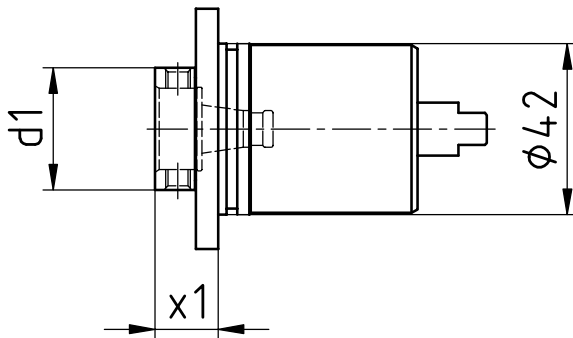

[mm]	[mm]	Spindle	[Nm]	[rpm]		Outside cooling	Internal cooling	[bar]	Order no.
d1	x1	Broche	T max	n max	i	Lubrificat. ext.	Lubrificat. cent.	p	N° de Code
		Spindel				Aussenkühlung	Innenkühlung		Bestellnummer
30	15,5	WFB 20-12	10	8.000	1:1				MPU.Z42.B20.AA0.TS.R

# Tsugami

## Axial Bohr- und Fräskopf

Axial drilling and milling head

Outil de perçage et de fraisage axiale

**WG 35**

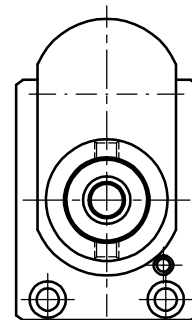
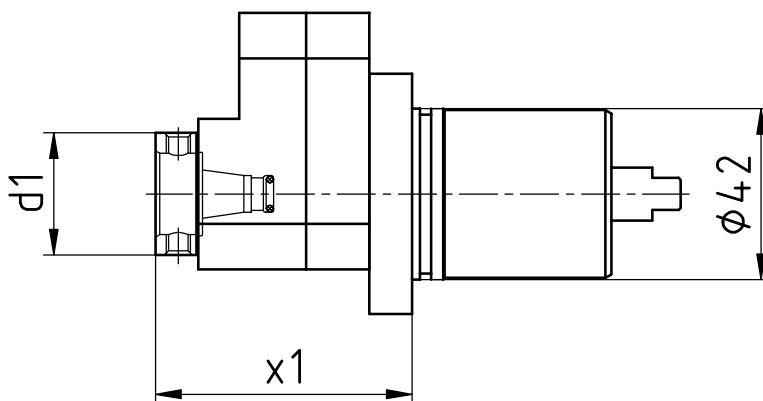
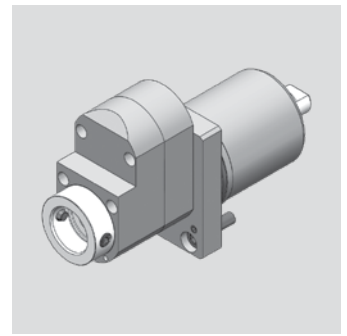

[mm]	[mm]	Spindle Broche <b>Spindel</b>	[Nm] <b>T max</b>	[rpm] <b>n max</b>	<b>i</b>	Outside cooling Lubrificat. ext. <b>Aussenkühlung</b>	Internal cooling Lubrificat. cent. <b>Innenkühlung</b>	[bar] <b>p</b>	Order no. N° de Code <b>Bestellnummer</b>
30	63	WFB 20-12	3	24.000	1:3				MPU.Z42.B20.BA0.TS.R

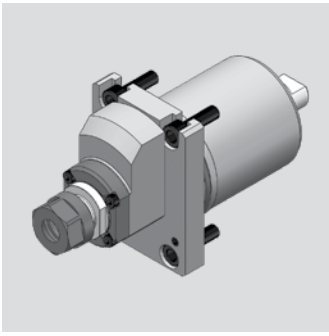

# Tsugami

## Axial Bohr- und Fräskopf

Axial drilling and milling head

Outil de perçage et de fraisage axiale

**WG 35**

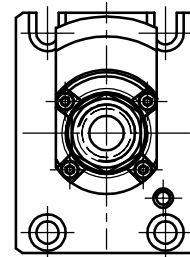
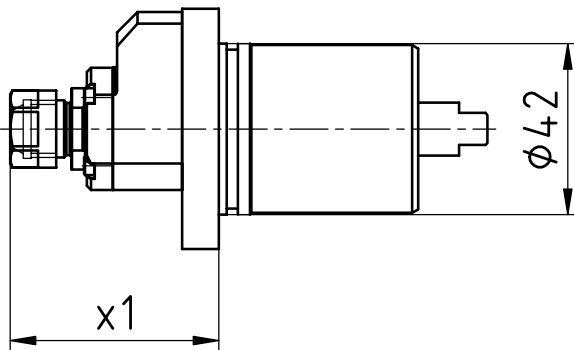

[mm]	[mm]	Spindle Broche <b>Spindel</b>	[Nm] <b>T max</b>	[rpm] <b>n max</b>	<b>i</b>	Outside cooling Lubrificat. ext. <b>Aussenkühlung</b>	Internal cooling Lubrificat. cent. <b>Innenkühlung</b>	[bar] <b>p</b>	Order no. N° de Code <b>Bestellnummer</b>
d1	x1								
19	51,2	ER11	2	32.000	1:4				MPU.Z42.E11.BA0.TSR.I4

# Tsugami

## Axial Bohr- und Fräskopf

Axial drilling and milling head

Outil de perçage et de fraisage axiale

WG 35

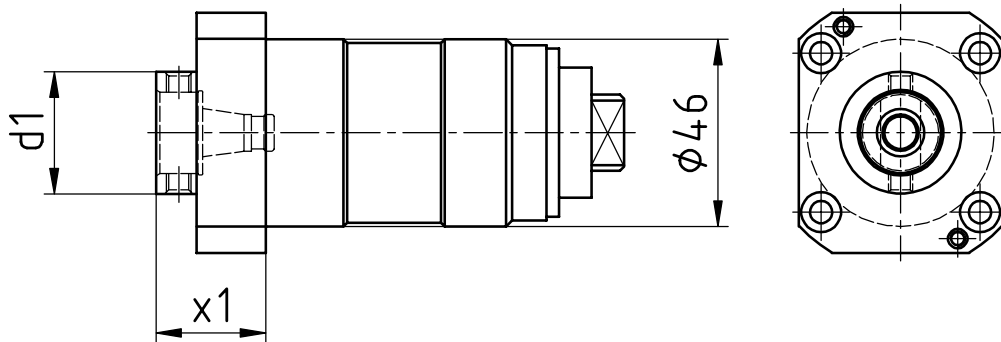
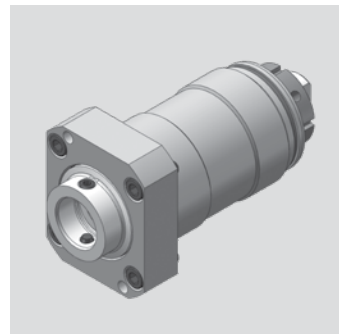

[mm]	[mm]	Spindle Broche <b>Spindel</b>	[Nm] <b>T max</b>	[rpm] <b>n max</b>	<b>i</b>	Outside cooling Lubrificat. ext. <b>Aussenkühlung</b>	Internal cooling Lubrificat. cent. <b>Innenkühlung</b>	[bar] <b>p</b>	Order no. N° de Code <b>Bestellnummer</b>
d1	x1	WFB 20-12	10	8.000	1:1				MPU.Z46.B20.AA0.TS

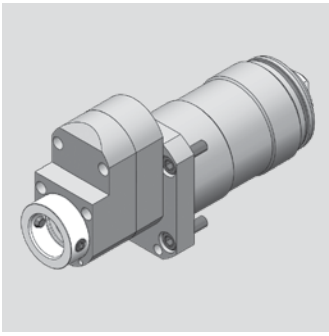

# Tsugami

## Axial Bohr- und Fräskopf

Axial drilling and milling head

Outil de perçage et de fraisage axiale

WG 35

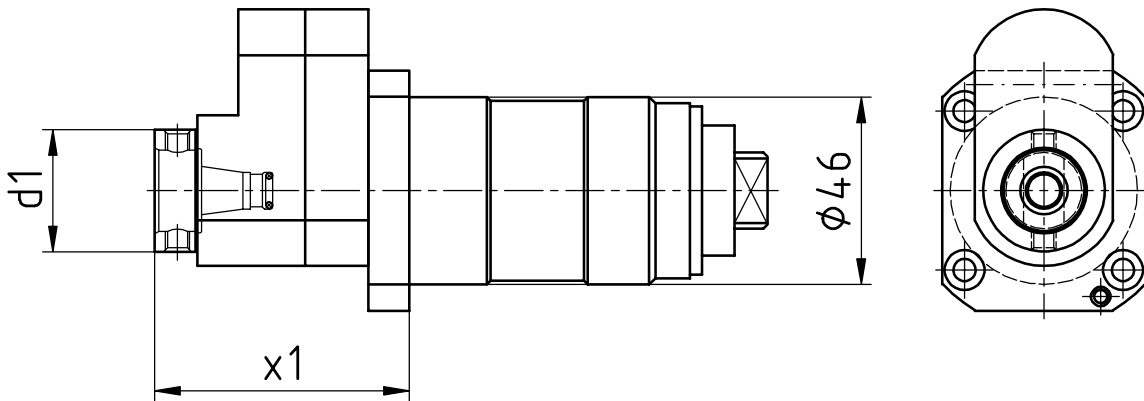

[mm]	[mm]	Spindle Broche <b>Spindel</b>	[Nm] <b>T max</b>	[rpm] <b>n max</b>	<b>i</b>	Outside cooling Lubrificat. ext. <b>Aussenkühlung</b>	Internal cooling Lubrificat. cent. <b>Innenkühlung</b>	[bar] <b>p</b>	Order no. N° de Code <b>Bestellnummer</b>
d1	x1	WFB 20-12	3	24.000	1:3				MPU.Z46.B20.BA0.TS

# Tsugami

## Axial Bohr- und Fräskopf

Axial drilling and milling head

Outil de perçage et de fraisage axiale

**WG 35**

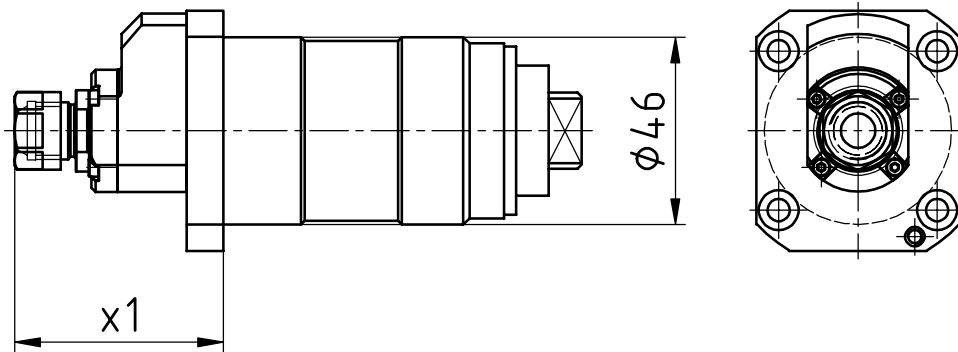
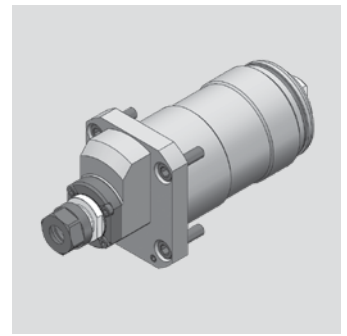

[mm]	[mm]	Spindle Broche <b>Spindel</b>	[Nm] <b>T max</b>	[rpm] <b>n max</b>	<b>i</b>	Outside cooling Lubrificat. ext. <b>Aussenkühlung</b>	Internal cooling Lubrificat. cent. <b>Innenkühlung</b>	[bar] <b>p</b>	Order no. N° de Code <b>Bestellnummer</b>
19	51,2	ER11	2	32.000	1:4				MPU.Z46.E11.BA0.TS.I4

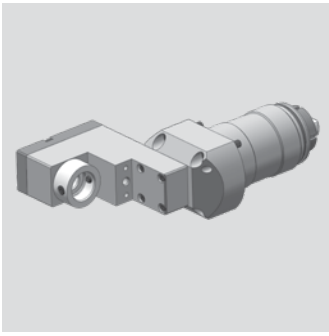

# Tsugami

**Radial Bohr- und Fräskopf**  
 Radial drilling and milling head  
 Outil de perçage et de fraisage radiale

**WG 35**

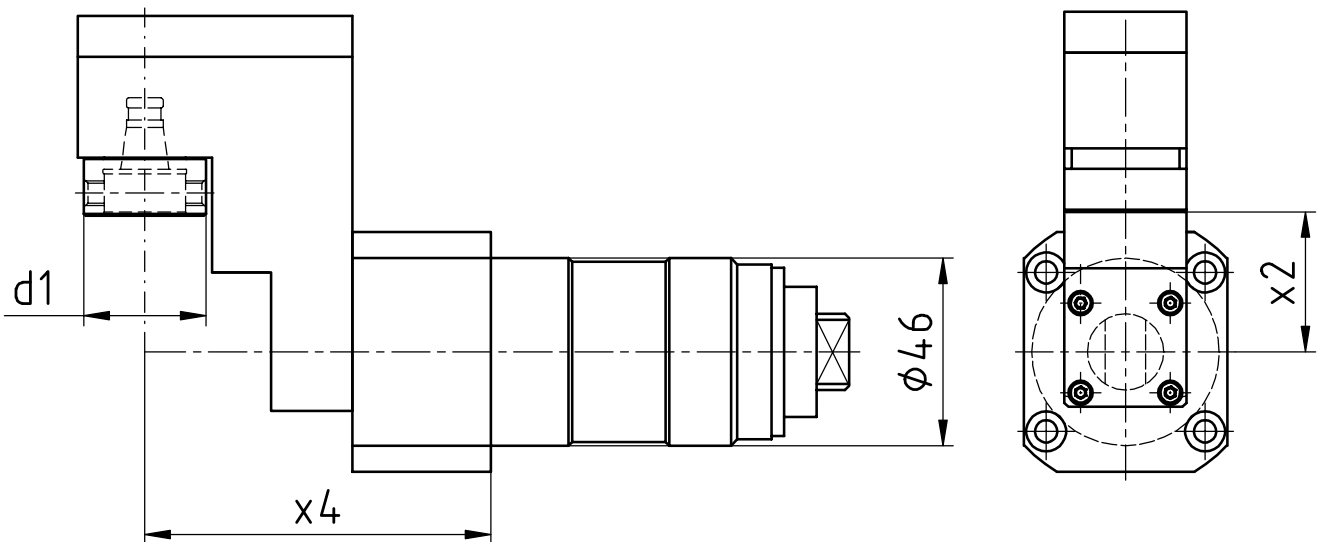

[mm]	[mm]	[mm]	Spindle Broche	[Nm]	[rpm]	Outside cooling Lubrificat. ext.	Internal cooling Lubrificat. cent.	[bar]	Order no. N° de Code
<b>d1</b>	<b>x2</b>	<b>x4</b>	<b>Spindel</b>	<b>T max</b>	<b>n max</b>	<b>Aussenkühlung</b>	<b>Innenkühlung</b>	<b>p</b>	<b>Bestellnummer</b>
30	34,4	85	ER11	10	8.000	1:1			MPU.Z46.B20.RA0.TS



# Tsugami

## Radial Bohr- und Fräskopf

Radial drilling and milling head

Outil de perçage et de fraisage radiale

WG 35

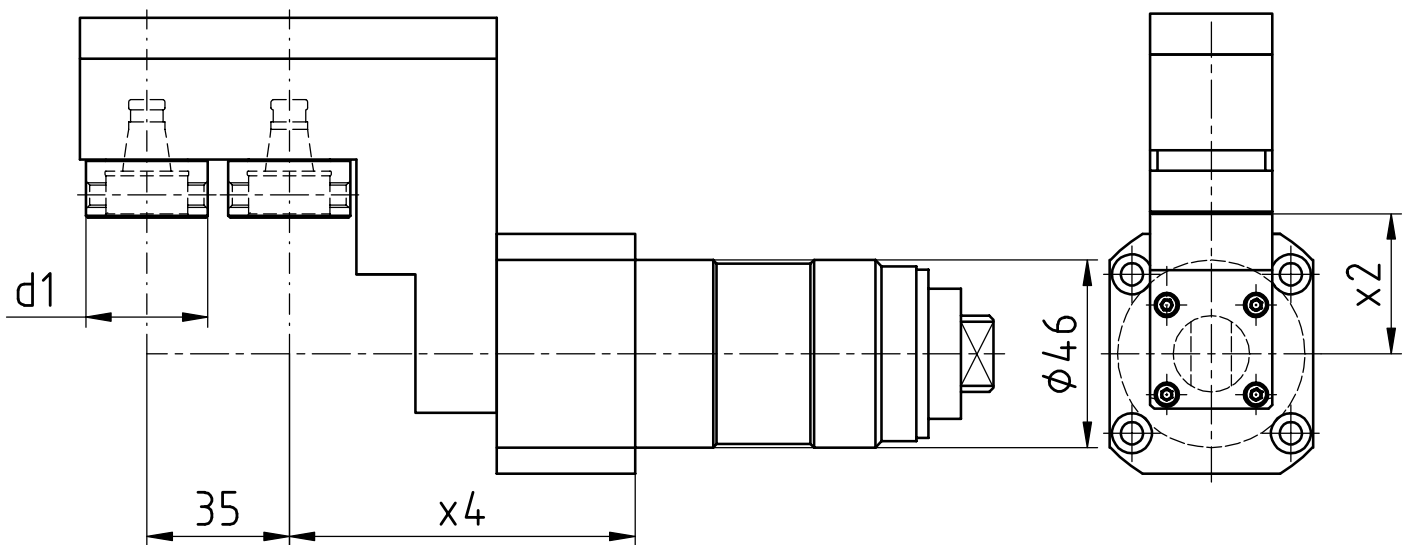
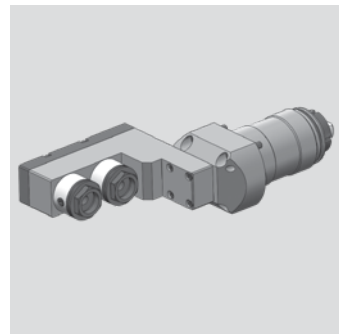

[mm]	[mm]	[mm]	Spindle Broche Spindel	[Nm] T max	[rpm] n max		Outside cooling Lubrificat. ext. Aussenkühlung	Internal cooling Lubrificat. cent. Innenkühlung	[bar] p	Order no. N° de Code Bestellnummer
d1	x2	x4			i					
30	34,4	85	ER11	10	8.000	1:1				MPU.Z46.B20.2A0.TS