

Modulare Aggregatetechnik

Schnellläufer

WF

Werkzeugtechnik

**Übersetzte Werkzeuge bis 32.000 U/min
und Innenkühlung bis 80 bar**

Speeders with up to 32.000 rpm and
internal coolant up to 80 bar



Katalog SL-01



Werkzeugtechnik

Kundenhinweise

Indications for the customer

**Sehr geehrter Kunde,
bitte beachten Sie folgende Hinweise:**

- Mit diesem Katalog wird die vorherige Ausgabe ungültig
- Technische Änderungen und Preisänderungen behalten wir uns vor
- Bildliche Darstellungen sind unverbindlich
- Für Druckfehler übernehmen wir keine Haftung
- Es gelten ausschließlich unsere allgemeinen Verkaufs- und Lieferbedingungen

**Dear Customer,
please note the following points:**

- This catalogue invalidates our former edition
- We reserve the right to make technical modifications and to change the price
- Pictorial illustrations are not binding
- We accept not any liability for print mistake
- Only our terms and conditions are valid

Inhaltsverzeichnis

Table of contents



Werkzeugtechnik

Beschreibung / Description	Seite / Page
Produktinformationen Product information	1.2
Citizen	2
DMG MORI	3
Hanwha	4
Maier	5
Nomura	6
Star	7
Tornos	8
Tsugami	9
WFB Adapter WFB adapter	10
Spannzangen und Zubehör Collets and accessories	11
Allgemeine Verkaufs- und Lieferbedingungen General sales terms and delivery conditions	12

WG = Warengruppe
Article group

WG 11 = _____

WG 35 = _____

WG 40 = _____



Werkzeugtechnik

Modulare Aggregatetechnik

Schnellläufer

Übersetzte Werkzeuge für Langdrehmaschinen

Neue Technologien im Bereich der Schneidwerkzeuge ermöglichen immer höhere Schnittgeschwindigkeiten. Doch diese können auf Grund von unzureichenden Antriebsdrehzahlen der Maschine oftmals nicht erreicht werden. Durch den Einsatz von Schnelllaufspindeln stellt dies jedoch kein Problem mehr dar und Sie können Ihr Produktionspotential voll ausschöpfen. Mit einer Übersetzung von $i = 1:4$ können, abhängig von der Maschine, Drehzahlen von bis zu 32.000 U/min umgesetzt werden. Somit können Sie mit unseren Schnelllaufspindeln auch bei Werkzeugen mit kleinen Durchmessern die erforderlichen Schnittgeschwindigkeiten realisieren.

Innovative Getriebetechnologie

Bei sämtlichen Schnellläufern setzt W&F auf neueste Getriebetechnologie mit einem Mehrstufengetriebe in kompakter Ausführung. Durch die Mehrstufenbauweise ist es möglich, trotz minimalem Bauraum, eine ausreichende Stabilität und Steifigkeit der Abgangsspindel zu erzielen. Die Lagerung ist so ausgelegt, dass ausreichend Lagerabstand vorhanden ist. Gleichermäßen war es dadurch auch möglich Innenkühlung ohne Stabilitätsverlust zu integrieren.

Im Gegensatz zur Planetengetriebetechnologie ergibt sich durch das von uns verwendete Mehrstufengetriebe eine deutlich reduzierte Störanfälligkeit des Werkzeughalters.

Effizienter durch Innenkühlung

Auf Grund unserer langjährigen Erfahrung im Bereich innengekühlter Werkzeuge, war es für uns ein logischer Schritt auch unsere Schnelllaufspindeln mit Innenkühlung zu entwickeln. Durch unsere bewährte Dichtungstechnologie können Kühlmitteldrücke von bis zu 80 bar realisiert werden.

Vorteile innengekühlter Schnelllaufspindeln

- gesteigerte Produktivität
- reduzierter Schneidenverschleiß
- höhere Schnittdaten
- bessere Oberflächengüte
- stabilere Prozesse



Geared tools for Swiss type lathes

New technologies in the field of cutting tools enable ever higher cutting speeds.

However, these often cannot be achieved due to insufficient drive speeds of the machine. With the use of high-speed spindles this is no longer a problem and you can fully exploit your production potential.

With a ratio of $i = 1:4$, depending on the machine, speeds up to 32,000 rpm can be implemented. This means that you can use our high-speed spindles to achieve the required cutting speeds even for tools with small diameters.

Innovative gear-technology

For all high-speed spindles, W&F relies on the latest gear technology with a multi-speed gear compact design. Thanks to the multi-stage design of the gearing, it is possible to achieve sufficient stability and rigidity of the outlet spindle. The bearing arrangement is designed in such a way, that there is sufficient bearing clearance. This also made it possible to integrate internal cooling without any loss of stability.

In contrast to planetary gear technology, the multi-stage gear we use, results in a significantly reduced susceptibility of the tool holder to failure.

Advantages of internally cooled high-speed spindles

- increased productivity
- reduced tool wear
- higher cutting speeds
- better surface quality
- more stable processes

More efficient through internal cooling

Due to our many years of experience in the field of internally cooled tools, it was a logical step for us to develop our high-speed spindles with internal cooling. Thanks to our proven sealing technology, coolant pressures of up to 80 bar can be achieved.



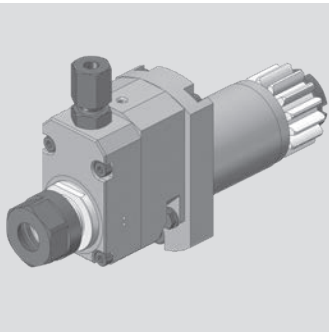

Citizen

Axial Bohr- und Fräskopf
Axial drilling and milling head

WG 35

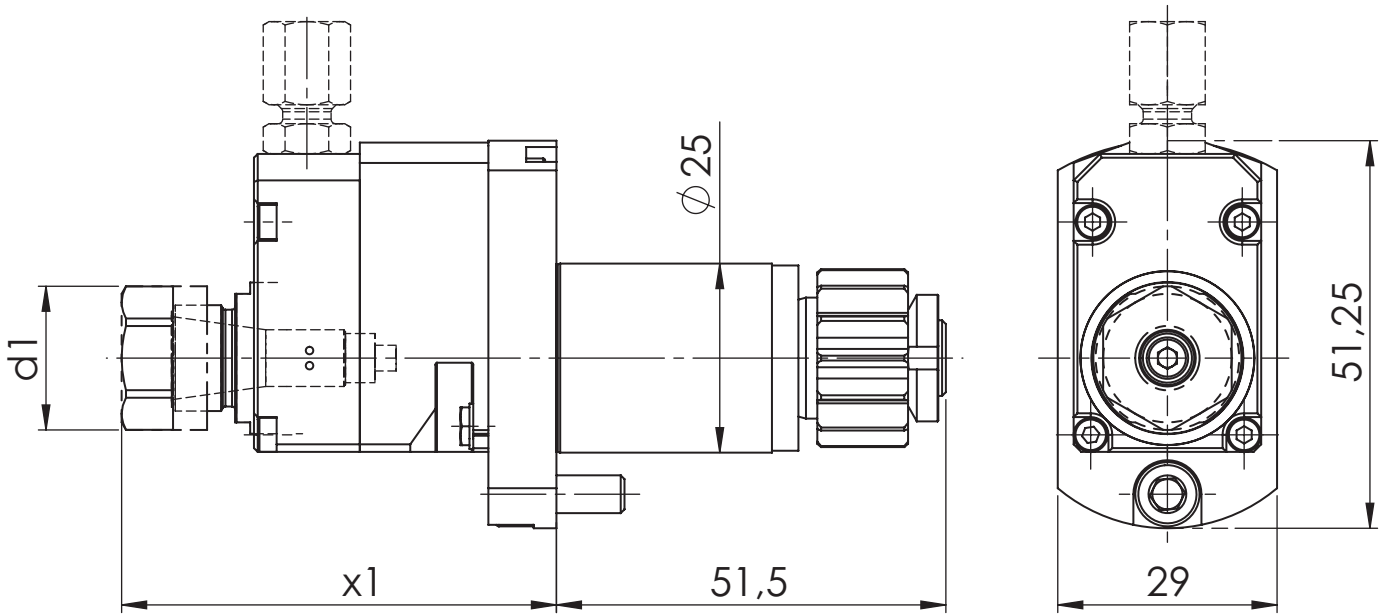

[mm]	[mm]	Spindle	[Nm]	[rpm]		Outside cooling	Internal cooling	[bar]	Order no.
d1	x1	Spindel	T max	n max	i	Aussenkühlung	Innenkühlung	p	Bestellnummer
19	51,2	ER11	2	32.000	1:4				MPU.Z25.E11.BA0.MSC507
19	57,5	ER11	2	32.000	1:4		x	80	MPU.Z25.E11.BE0.MSC507

Suitable Machines:

Passend für Maschine:

A20-3F7N	L20E-2M12	M212-V	M3212-V	M16-4M8
A320-VII	L20E-IX	M216-C	M312-VII	
L20E-2M8	L20X	M216-V	M316-III	
L20E-2M10	M212-C	M312-III	M16-4M5	

Similar to OEM no.

Ähnlich OEM Nr.

MSC-507

Citizen

Axial Bohr- und Fräskopf
Axial drilling and milling head

WG 35

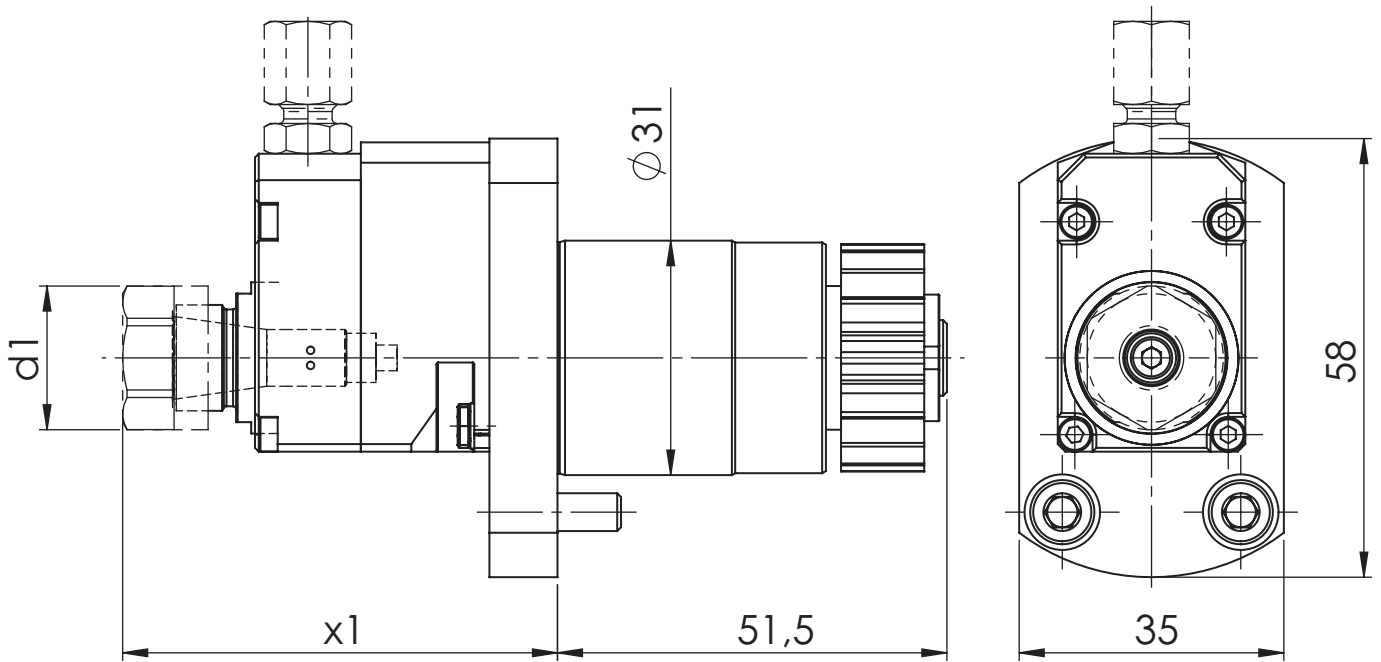
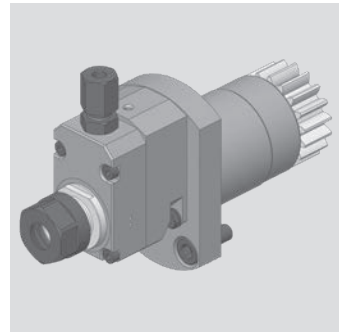

[mm]	[mm]	Spindle	[Nm]	[rpm]		Outside cooling	Internal cooling	[bar]	Order no.
d1	x1	Spindel	T max	n max	i	Aussenkühlung	Innenkühlung	p	Bestellnummer
19	51,2	ER11	2	32.000	1:4				MPU.Z31.E11.BA0.1310I4
19	57,5	ER11	2	32.000	1:4		x	80	MPU.Z31.E11.BE0.1310I4

Suitable Machines:
Passend für Maschine:

A232-VII	L20E-2M10	L220-2M8	M32-5M5
A32-VII	L32-1M8	L220-2M10	M32-5M7
A320-VII	L32-1M10	M32-4M5	M32-5M8
L20E-2M8	L32-1M12	M32-4M8	D25-VII

Similar to OEM no.
Ähnlich OEM Nr.

GSC-1310

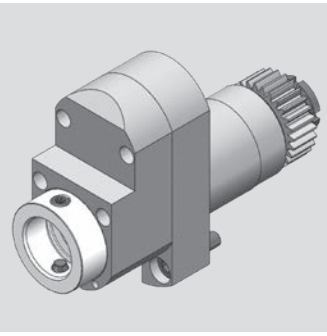

Citizen

Axial Bohr- und Fräskopf
Axial drilling and milling head

WG 35

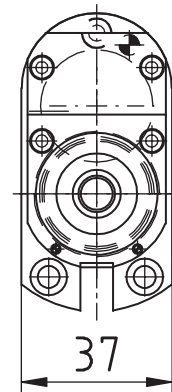
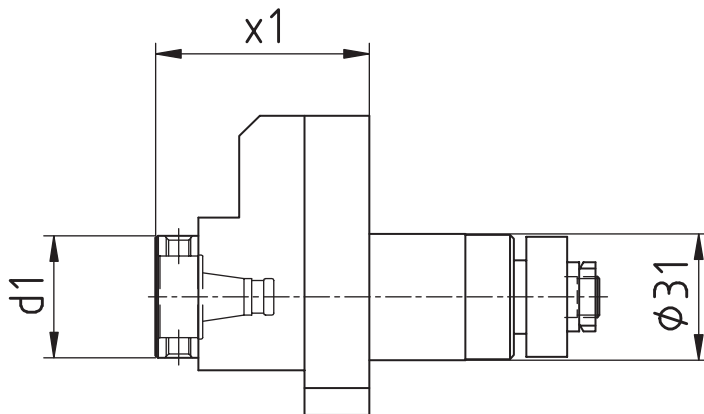

[mm]	[mm]	Spindle	[Nm]	[rpm]		Outside cooling	Internal cooling	[bar]	Order no.
d1	x1	Spindel	T max	n max	i	Aussenkühlung	Innenkühlung	p	Bestellnummer
30	52,5	WFB 20-12	3	18.000	1:3				MPU.Z31.B20.BA0.1310I3

Similar to OEM no.
Ähnlich OEM Nr.

GSC-1310

Suitable Machines:

Passend für Maschine:

A20-3F7N	L20E-2M8	L32-1M12	M232-V	M32-4M5
A232-VII	L20E-2M10	M220-III	M320-V	M32-5M8
A32-VII	L32-1M8	M220-V	M332-III	
A320-VII	L32-1M10	M232-III	M332-V	

Spare Parts
Ersatzteile

threaded taper pin	Quantity	Tightening torque [Nm]	Order no.
Kegelgewindestift	Anzahl	Anzugsmoment [Nm]	Bestellnummer
M6X0,75	2	4	WFS.M6X0,75.TORX15PLUS

Citizen

Axial Bohr- und Fräskopf
Axial drilling and milling head

WG 35

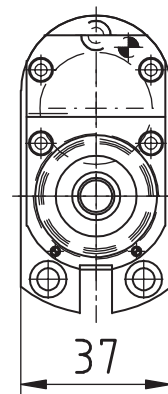
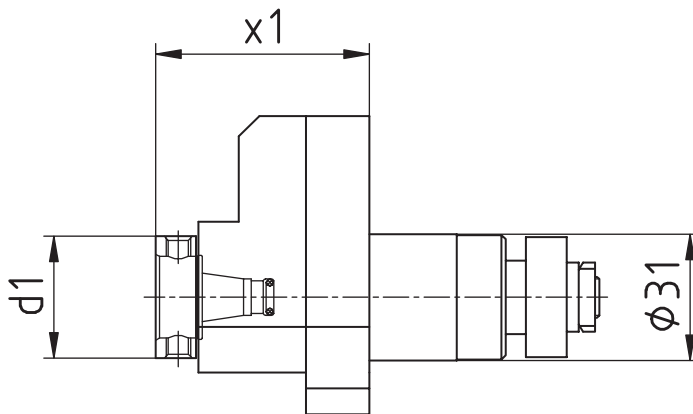
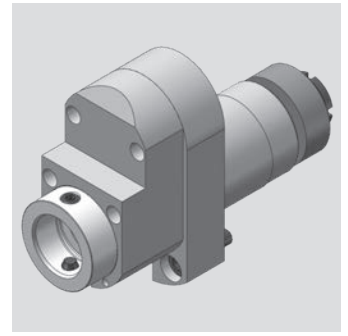

[mm]	[mm]	Spindle	[Nm]	[rpm]		Outside cooling	Internal cooling	[bar]	Order no.
d1	x1	Spindel	T max	n max	i	Aussenkühlung	Innenkühlung	p	Bestellnummer
30	52,5	WFB 20-12	3	18.000	1:3				MPU.Z31.B20.BA0.L20R

Similar to OEM no.
Ähnlich OEM Nr.

GSC-1210

Suitable Machines:
Passend für Maschine:

L20E2M8 L20E-IX
L20E2M10
L20E2M12

Spare Parts
Ersatzteile

threaded taper pin	Quantity	Tightening torque [Nm]	Order no.
Kegelgewindestift	Anzahl	Anzugsmoment [Nm]	Bestellnummer

M6X0,75	2	4	WFS.M6X0,75.TORX15PLUS
---------	---	---	------------------------

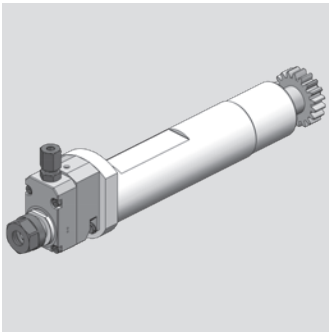

Citizen

Axial Bohr- und Fräskopf
Axial drilling and milling head

WG 35

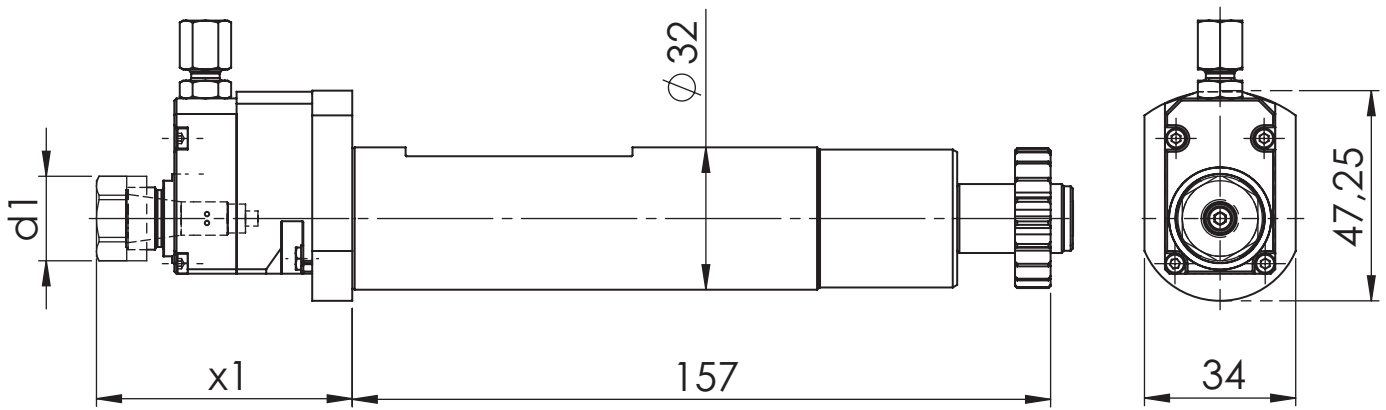

[mm]	[mm]	Spindle	[Nm]	[rpm]		Outside cooling	Internal cooling	[bar]	Order no.
d1	x1	Spindel	T max	n max	i	Aussenkühlung	Innenkühlung	p	Bestellnummer
19	51,2	ER11	2	24.000	1:4				MPU.Z32.E11.BA0.L20.1
19	57,5	ER11	2	24.000	1:4		x	80	MPU.Z32.E11.BE0.L20.1

Suitable Machines:

Passend für Maschine:

L20E-2M8	L20V	M20-2M3	M32-2M3
L20E-2M10	L20VII	M20-2M5	M32-2M5
L20E-1M12	L20VIII	M20-3M3	M32-3M3
L20E IX	L20X	M20-3M5	M32-3M5

Similar to OEM no.

Ähnlich OEM Nr.

GSC-510

Citizen

Axial Bohr- und Fräskopf
Axial drilling and milling head

WG 35

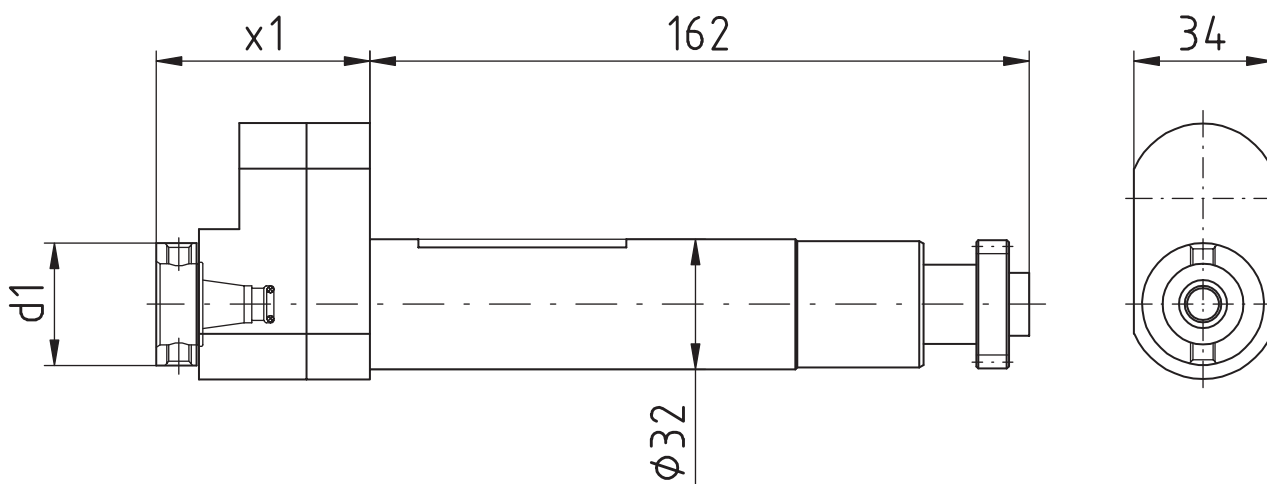
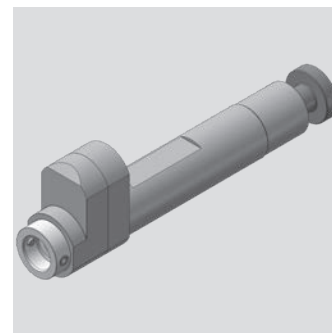

[mm]	[mm]	Spindle	[Nm]	[rpm]		Outside cooling	Internal cooling	[bar]	Order no.
d1	x1	Spindel	T max	n max	i	Aussenkühlung	Innenkühlung	p	Bestellnummer
30	52,5	WFB 20-12	3	18.000	1:3				MPU.GSC.510.AA0.B20

Similar to OEM no.
Ähnlich OEM Nr.

GSC-510

Suitable Machines:
Passend für Maschine:

L20E2M8	L20E-IX	L20X	M232-III	M332-III
L20E2M10	L20V	M220-III	M320-III	M332-V
L20E1M12	L20VIII	M220-V	M320-V	M32-4M5/M8

Spare Parts
Ersatzteile

threaded taper pin	Quantity	Tightening torque [Nm]	Order no.
Kegelgewindestift	Anzahl	Anzugsmoment [Nm]	Bestellnummer
M6X0,75	2	4	WFS.M6X0,75.TORX15PLUS



Citizen

Axial Bohr- und Fräskopf
Axial drilling and milling head

WG 35

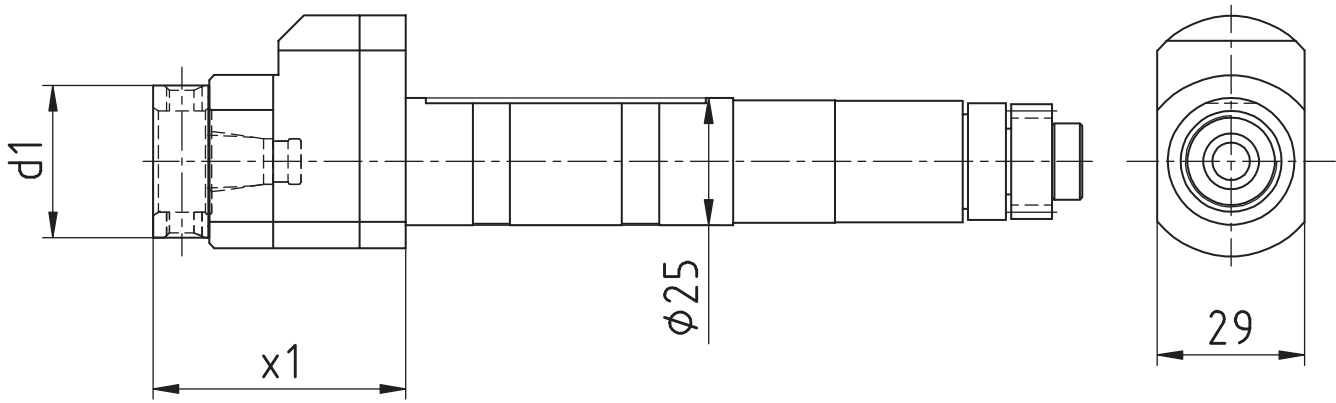

[mm]	[mm]	Spindle	[Nm]	[rpm]		Outside cooling	Internal cooling	[bar]	Order no.
d1	x1	Spindel	T max	n max	i	Aussenkühlung	Innenkühlung	p	Bestellnummer
29	49,6	WFB 20-12	3	24.000	1:3				MPU.GSC.607.BA0.B20

Similar to OEM no.
Ähnlich OEM Nr.

GSC-607

Suitable Machines:

Passend für Maschine:

M212-C	M216-V	M316-III
M212-V	M312-III	M316-V
M216-C	M312-V	

Spare Parts
Ersatzteile

threaded taper pin	Quantity	Tightening torque [Nm]	Order no.
Kegelgewindestift	Anzahl	Anzugsmoment [Nm]	Bestellnummer

M6X0,75	2	4	WFS.M6X0,75.TORX15PLUS
---------	---	---	------------------------

Citizen

Axial Bohr- und Fräskopf
Axial drilling and milling head

WG 35

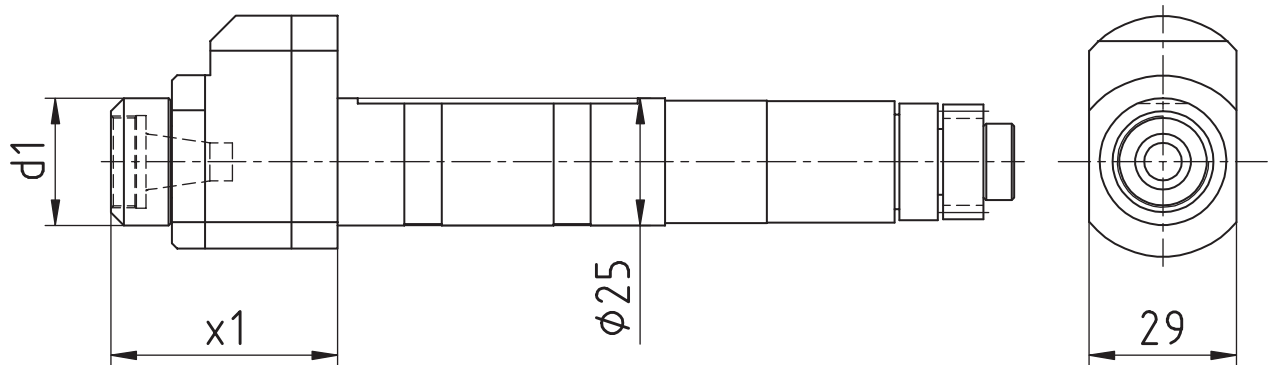
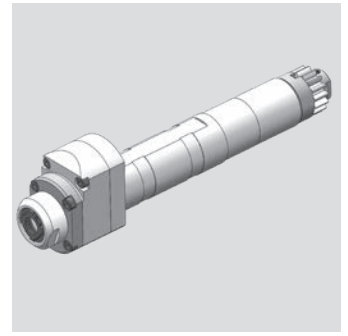

[mm]	[mm]	Spindle	[Nm]	[rpm]		Outside cooling	Internal cooling	[bar]	Order no.
d1	x1	Spindel	T max	n max	i	Aussenkühlung	Innenkühlung	p	Bestellnummer
25	44,5	ER11	3	24.000	1:3				MPU.GSC.607.BA0.E11

Suitable Machines:
Passend für Maschine:

M212-C	M216-V	M316-III
M212-V	M312-III	M316-V
M216-C	M312-V	

Similar to OEM no.
Ähnlich OEM Nr.

GSC-607

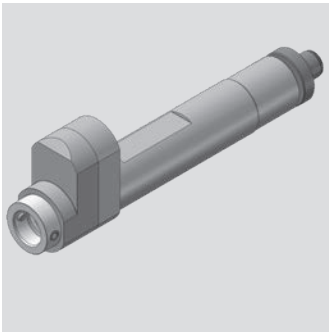

Citizen

Axial Bohr- und Fräskopf
Axial drilling and milling head

WG 35

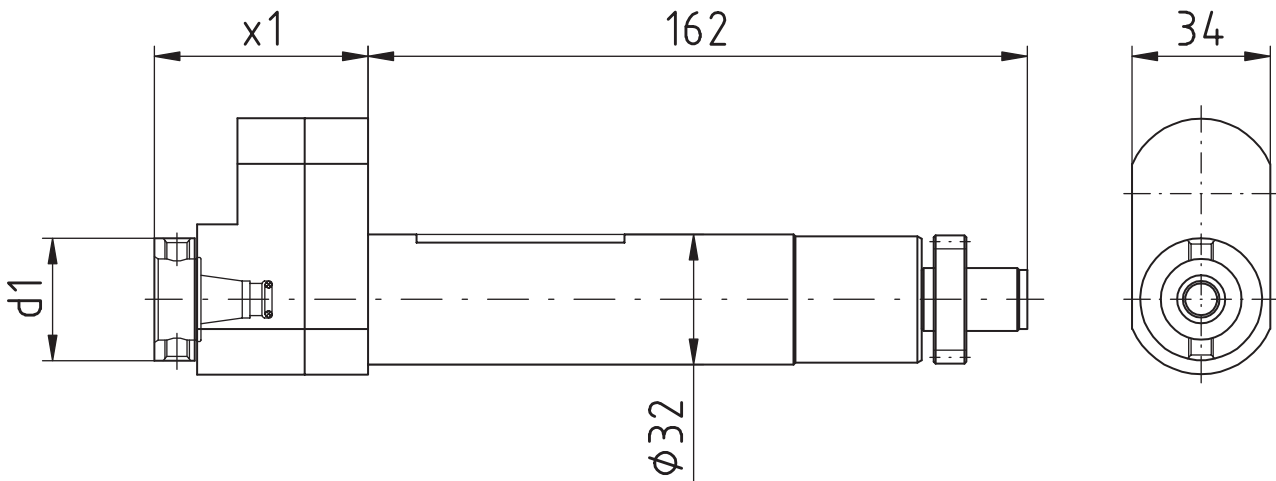

[mm]	[mm]	Spindle	[Nm]	[rpm]		Outside cooling	Internal cooling	[bar]	Order no.
d1	x1	Spindel	T max	n max	i	Aussenkühlung	Innenkühlung	p	Bestellnummer
30	52,5	WFB 20-12	3	18.000	1:3				MPU.GSC.610.AA0.B20

Similar to OEM no.
Ähnlich OEM Nr.

GSC-610

Suitable Machines:

Passend für Maschine:

L25

L32

Spare Parts

Ersatzteile

threaded taper pin	Quantity	Tightening torque [Nm]	Order no.
Kegelgewindestift	Anzahl	Anzugsmoment [Nm]	Bestellnummer

M6X0,75	2	4	WFS.M6X0,75.TORX15PLUS
---------	---	---	------------------------

Citizen

Axial Bohr- und Fräskopf
Axial drilling and milling head

WG 35

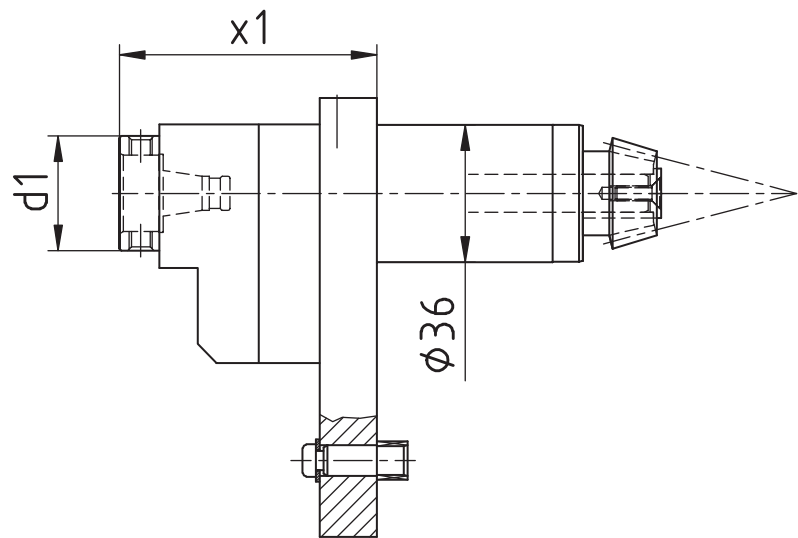
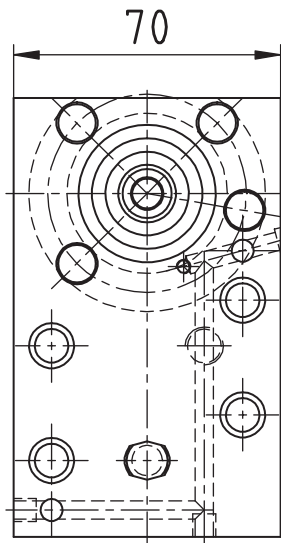
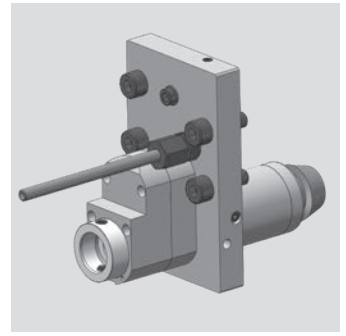

[mm]	[mm]	Spindle	[Nm]	[rpm]		Outside cooling	Internal cooling	[bar]	Order no.
d1	x1	Spindel	T max	n max	i	Aussenkühlung	Innenkühlung	p	Bestellnummer
30	67,5	WFB 20-12	3	15.000	1:3	x			MPU.KSC.110.BA0.B20

Similar to OEM no.

Ähnlich OEM Nr.

KSC-110

Suitable Machines:

Passend für Maschine:

M220-III	M232-V	M332-III	M32-4M8
M220-V	M320-III	M332-V	
M232-III	M320-V	M32-4M5	

Spare Parts

Ersatzteile

threaded taper pin	Quantity	Tightening torque [Nm]	Order no.
Kegelgewindestift	Anzahl	Anzugsmoment [Nm]	Bestellnummer
M6X0,75	2	4	WFS.M6X0,75.TORX15PLUS

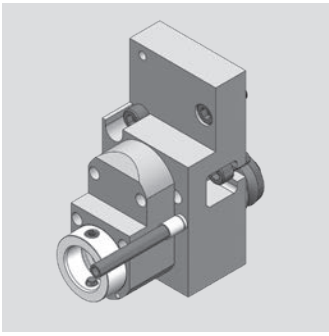

Citizen

Axial Bohr- und Fräskopf
Axial drilling and milling head

WG 35

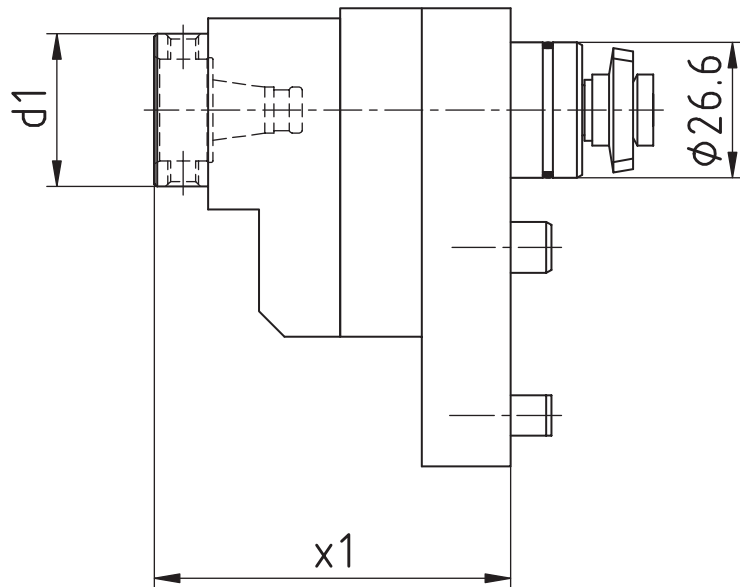
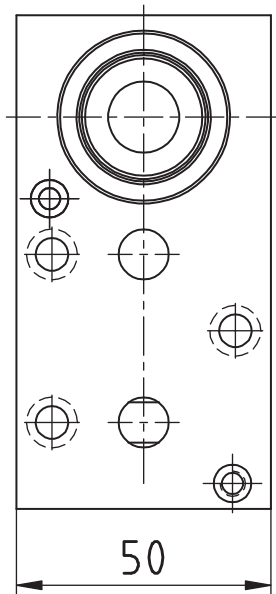

[mm]	[mm]	Spindle	[Nm]	[rpm]		Outside cooling	Internal cooling	[bar]	Order no.
d1	x1	Spindel	T max	n max	i	Aussenkühlung	Innenkühlung	p	Bestellnummer
30	70	WFB 20-12	3	18.000	1:3				MPU.MSC.106.BA0.B20

Similar to OEM no.
Ähnlich OEM Nr.

GSC-1310

Suitable Machines:

Passend für Maschine:

M212-C	M216-V	M316-III	M16-4MB
M212-V	M312-III	M316-V	
M216-C	M312-V	M16-4MS	

Spare Parts
Ersatzteile

threaded taper pin	Quantity	Tightening torque [Nm]	Order no.
Kegelgewindestift	Anzahl	Anzugsmoment [Nm]	Bestellnummer

M6X0,75	2	4	WFS.M6X0,75.TORX15PLUS
---------	---	---	------------------------

DMG MORI - SPRINT

Axial Bohr- und Fräskopf
Axial drilling and milling head

WG 35

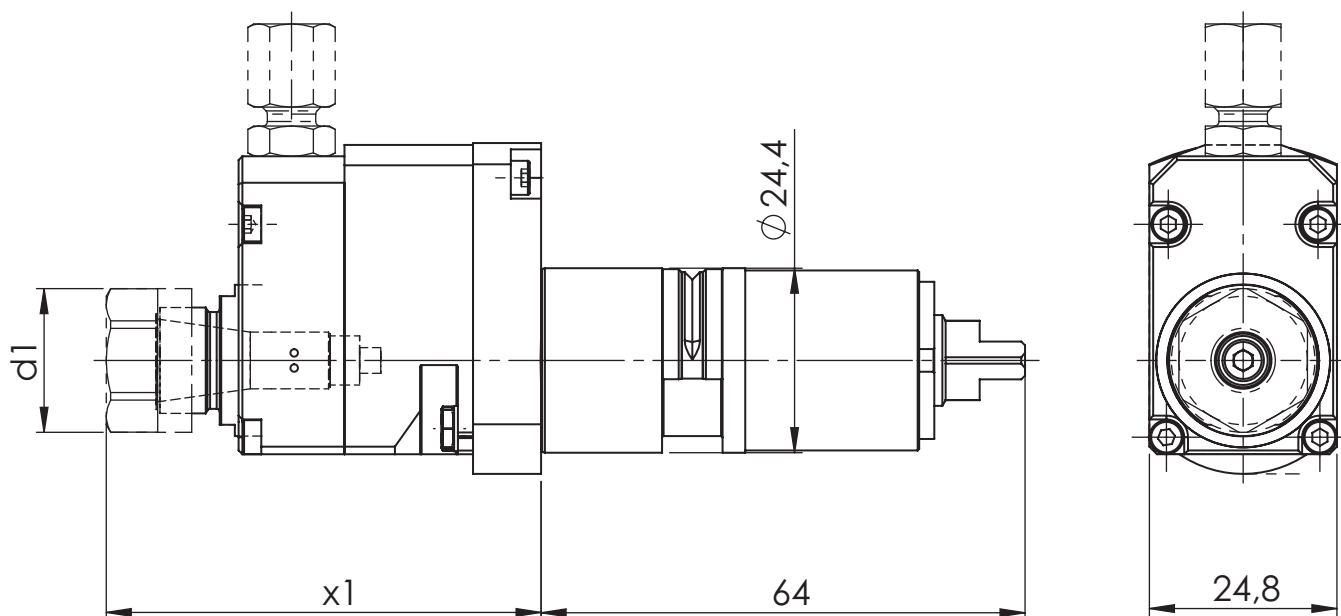
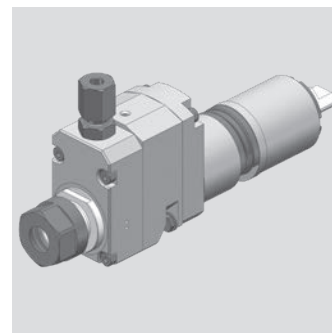

[mm]	[mm]	Spindle	[Nm]	[rpm]		Outside cooling	Internal cooling	[bar]	Order no.
d1	x1	Spindel	T max	n max	i	Aussenkühlung	Innenkühlung	p	Bestellnummer
19	51,2	ER11	2	24.000	1:4				MPU.Z24.E11.BA0.SP20
19	57,5	ER11	2	24.000	1:4		x	80	MPU.Z24.E11.BE0.SP20

Suitable Machines:

Passend für Maschine:

Sprint 2015 Speed 2018
Sprint 2018 Speed 20111
Sprint 2018 linear Speed 1217 linear

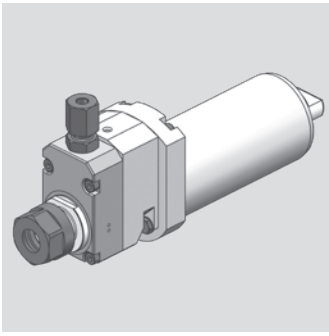

DMG MORI - SPRINT

Axial Bohr- und Fräskopf
Axial drilling and milling head

WG 35

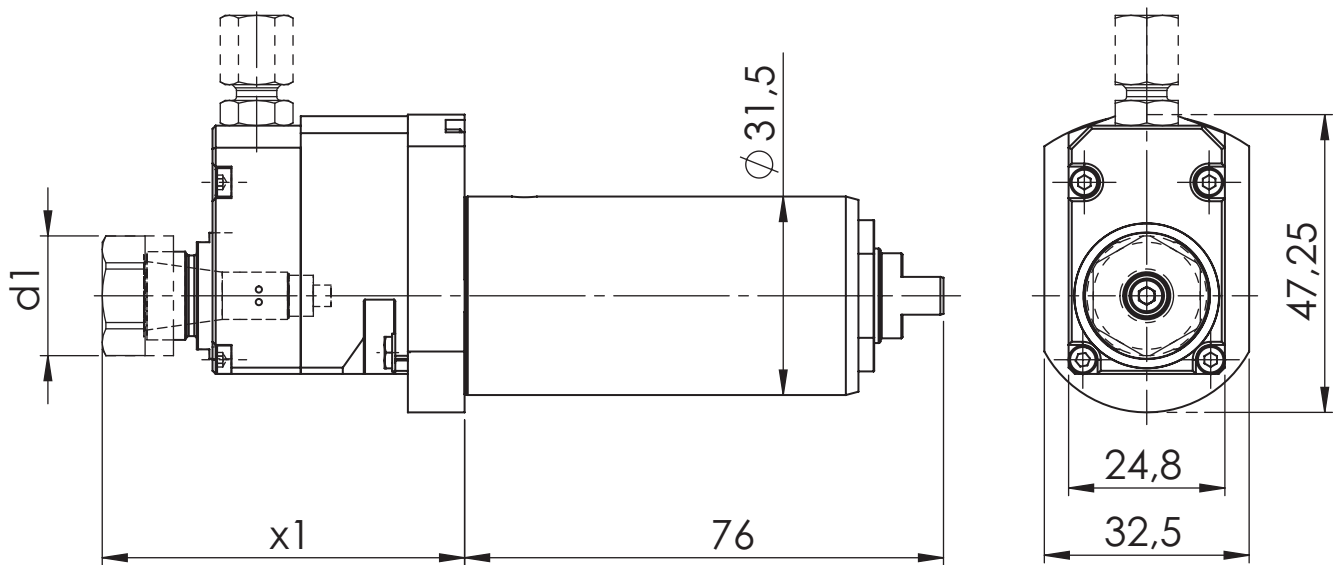

[mm]	[mm]	Spindle	[Nm]	[rpm]		Outside cooling	Internal cooling	[bar]	Order no.
d1	x1	Spindel	T max	n max	i	Aussenkühlung	Innenkühlung	p	Bestellnummer
19	51,2	ER11	2	24.000	1:4				MPU.M31.E11.BA0.SP42
19	57,5	ER11	2	24.000	1:4		x	80	MPU.M31.E11.BE0.SP42

Suitable Machines:

Passend für Maschine:

Sprint 3215 Sprint 42/10 linear
Sprint 3218 Speed 32/10 linear
Sprint 42 linear

DMG MORI - SPRINT

Radial Bohr- und Fräskopf
Radial drilling and milling head

WG 35

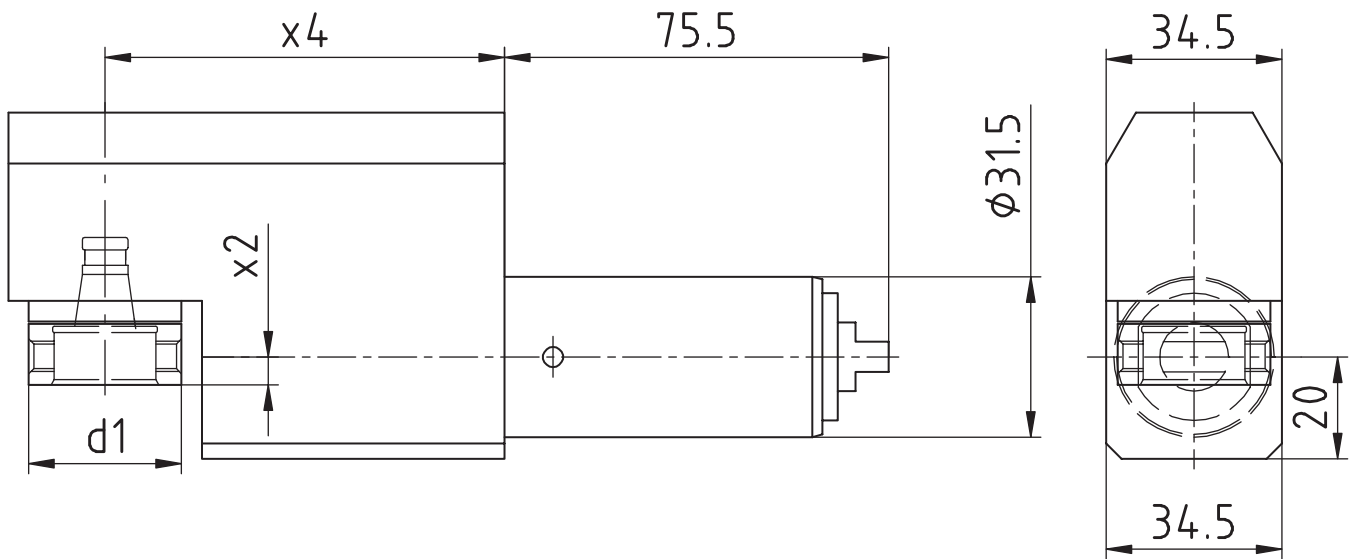
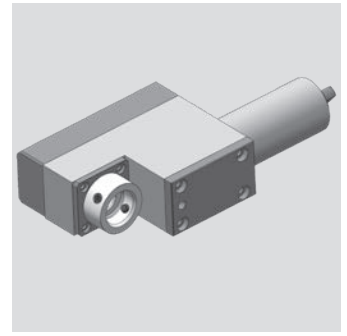

[mm]	[mm]	[mm]	Spindle	[Nm]	[rpm]		Outside cooling	Internal cooling	[bar]	Order no.
d1	x2	x4	Spindel	T max	n max	i	Aussenkühlung	Innenkühlung	p	Bestellnummer
30	5,5	78,5	WFB 20-12	3	19.500	1:3				MPU.M31.B20.ZA0.SP42
30	5,5	78,5	WFB 20-12	3	19.500	1:3		x	80	MPU.M31.B20.ZE0.SP42

Suitable Machines:

Passend für Maschine:

Sprint 3215 Sprint 42110 linear
Sprint 3218 Speed 32110 linear
Sprint 42 linear

Spare Parts

Ersatzteile

threaded taper pin	Quantity	Tightening torque [Nm]	Order no.
Kegelgewindestift	Anzahl	Anzugsmoment [Nm]	Bestellnummer
M6X0,75	2	4	WFS.M6X0,75.TORX15PLUS

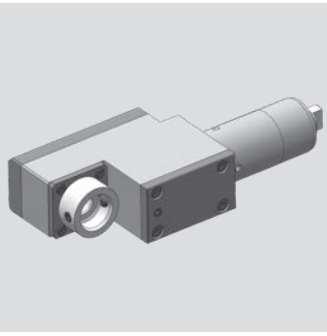

DMG MORI - SPRINT

Radial Bohr- und Fräskopf
Radial drilling and milling head

WG 35

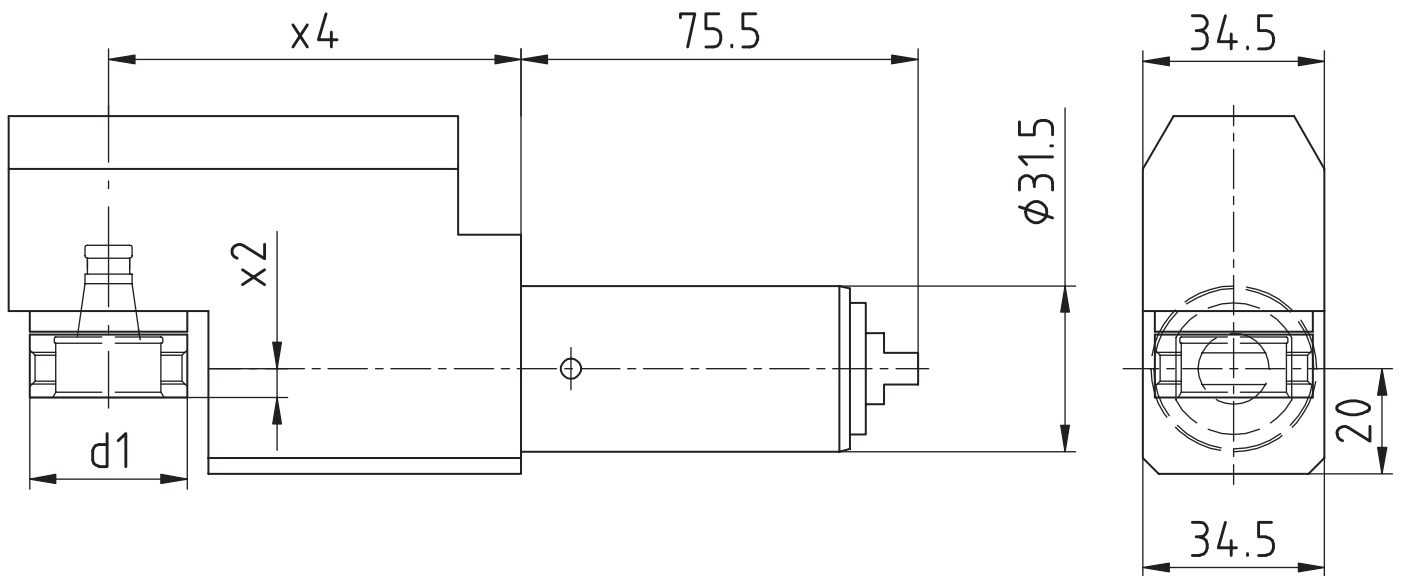

[mm]	[mm]	[mm]	Spindle	[Nm]	[rpm]		Outside cooling	Internal cooling	[bar]	Order no.
d1	x2	x4	Spindel	T max	n max	i	Aussenkühlung	Innenkühlung	p	Bestellnummer
30	5,5	78,5	WFB 20-12	3	19.500	1:3				MPU.M31.B20.ZA0.SP42RS

Suitable Machines:

Passend für Maschine:

Sprint 3215 Sprint 42|10 linear
Sprint 3218 Speed 32|10 linear
Sprint 42 linear

Spare Parts

Ersatzteile

threaded taper pin	Quantity	Tightening torque [Nm]	Order no.
Kegelgewindestift	Anzahl	Anzugsmoment [Nm]	Bestellnummer

M6X0,75	2	4	WFS.M6X0,75.TORX15PLUS
---------	---	---	------------------------

Hanwha

Axial Bohr- und Fräskopf
Axial drilling and milling head

WG 35

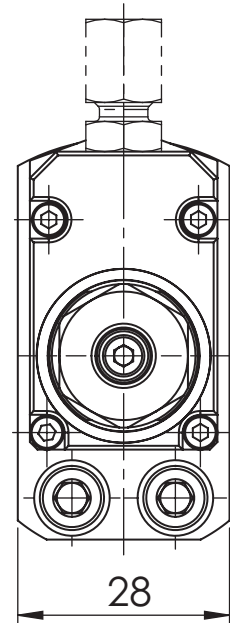
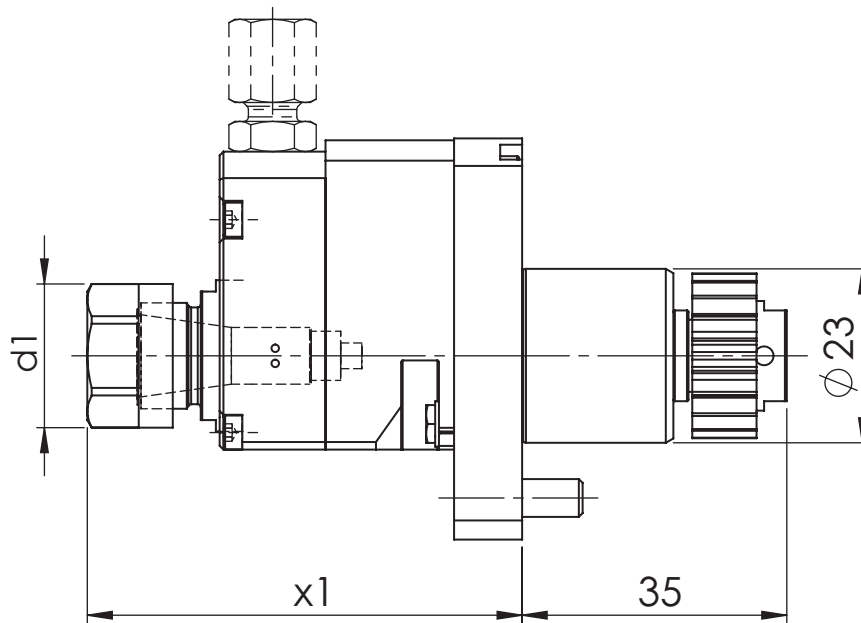
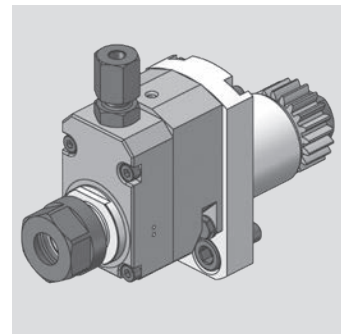

[mm]	[mm]	Spindle	[Nm]	[rpm]		Outside cooling	Internal cooling	[bar]	Order no.
d1	x1	Spindel	T max	n max	i	Aussenkühlung	Innenkühlung	p	Bestellnummer
19	51,2	ER11	2	32.000	1:4				MPU.Z23.E11.BA0.XD1216
19	57,5	ER11	2	32.000	1:4		x	80	MPU.Z23.E11.BE0.XD1216

Suitable Machines:
Passend für Maschine:

XD12 XD16 V
XD12 II XD16 II
XD16 H

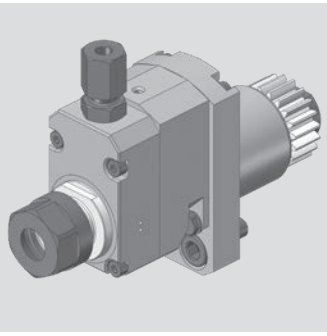

Hanwha

Axial Bohr- und Fräskopf
Axial drilling and milling head

WG 35

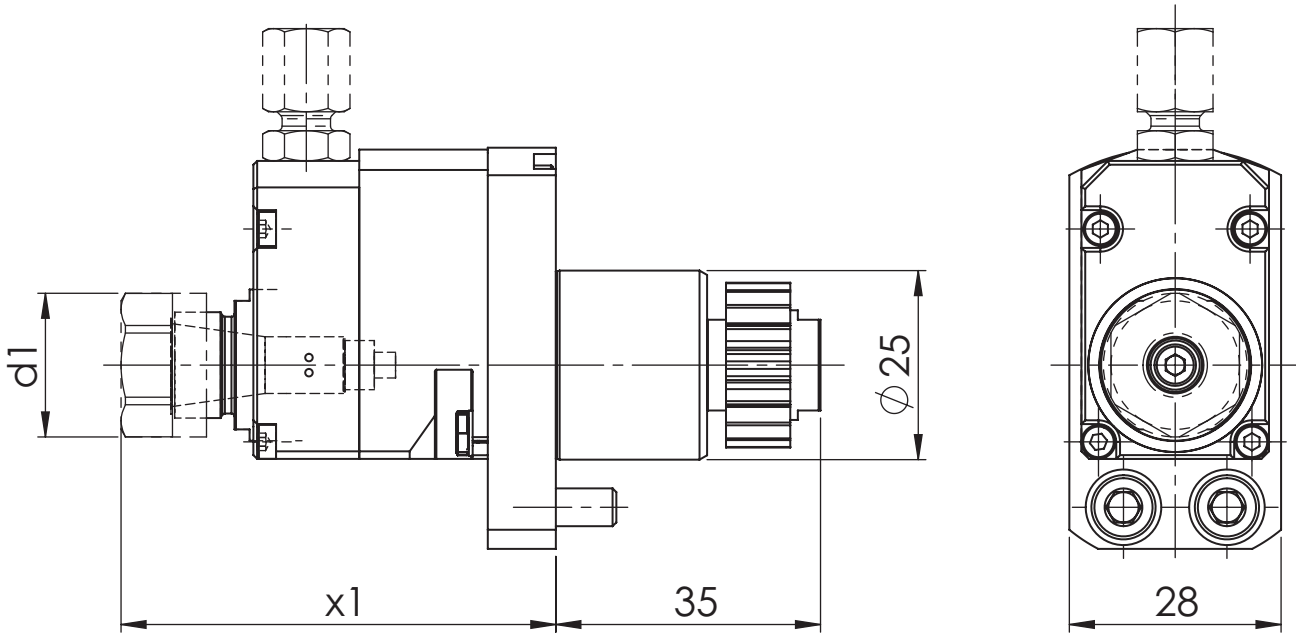

[mm]	[mm]	Spindle	[Nm]	[rpm]		Outside cooling	Internal cooling	[bar]	Order no.
d1	x1	Spindel	T max	n max	i	Aussenkühlung	Innenkühlung	p	Bestellnummer
19	51,2	ER11	2	32.000	1:4				MPU.Z25.E11.BA0.XD1216
19	57,5	ER11	2	32.000	1:4		x	80	MPU.Z25.E11.BE0.XD1216

Suitable Machines:

Passend für Maschine:

XD12 III H XD16 III J

XD12 III J

XD16 III H

Hanwha

Axial Bohr- und Fräskopf
Axial drilling and milling head

WG 35

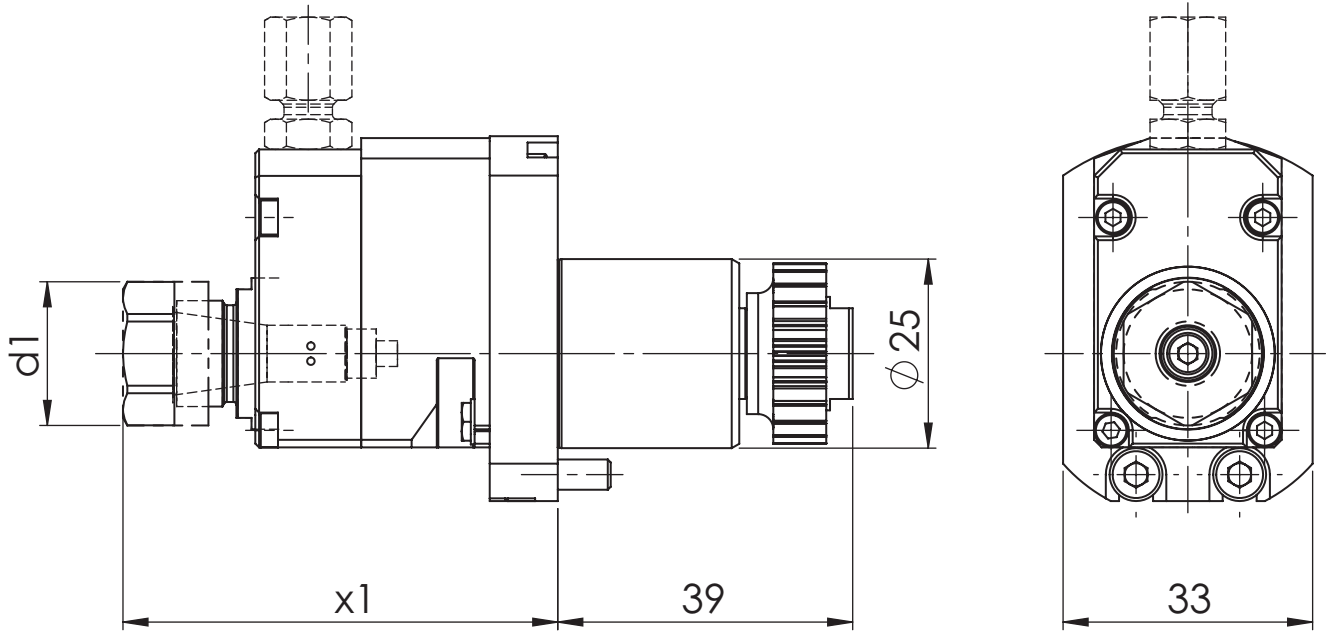
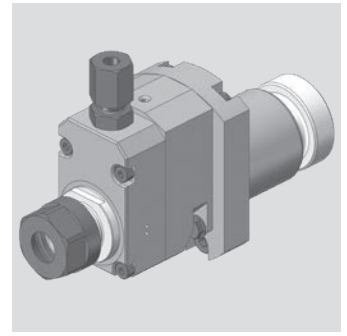

[mm]	[mm]	Spindle	[Nm]	[rpm]		Outside cooling	Internal cooling	[bar]	Order no.
d1	x1	Spindel	T max	n max	i	Aussenkühlung	Innenkühlung	p	Bestellnummer
19	51,2	ER11	2	32.000	1:4				MPU.Z25.E11.BA0.XD20V
19	57,5	ER11	2	32.000	1:4		x	80	MPU.Z25.E11.BE0.XD20V

Suitable Machines:
Passend für Maschine:

XD20 V

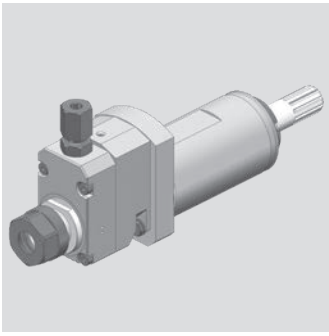

Hanwha

Axial Bohr- und Fräskopf
Axial drilling and milling head

WG 35

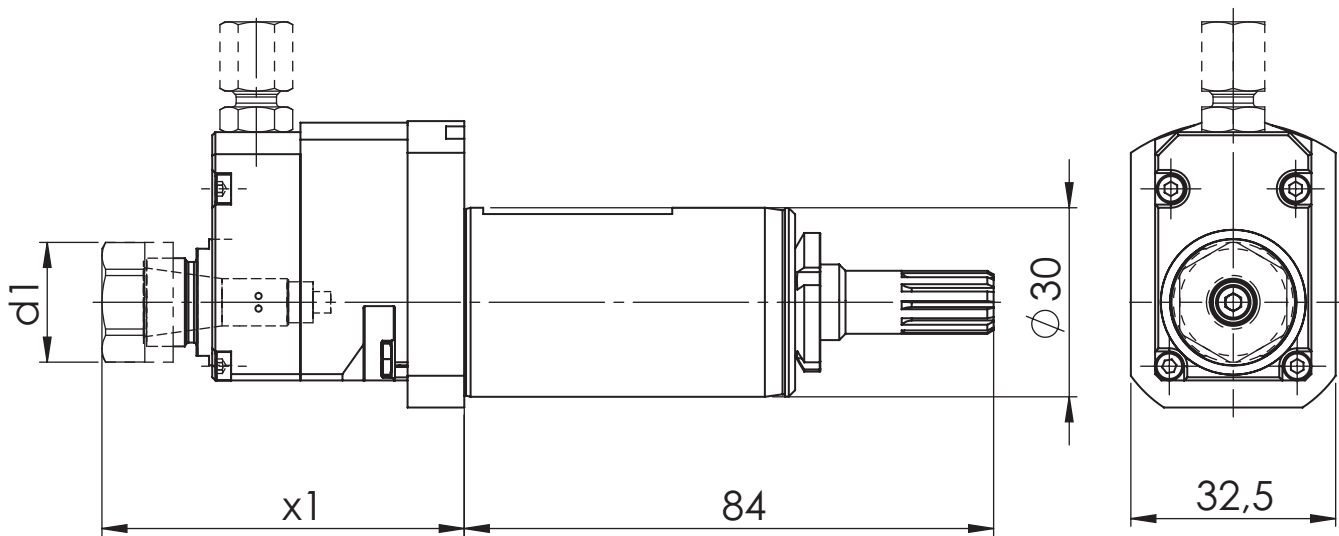

[mm]	[mm]	Spindle	[Nm]	[rpm]		Outside cooling	Internal cooling	[bar]	Order no.
d1	x1	Spindel	T max	n max	i	Aussenkühlung	Innenkühlung	p	Bestellnummer
19	51,2	ER11	2	32.000	1:4				MPU.Z30.E11.BA0.XD20.1
19	57,5	ER11	2	32.000	1:4		x	80	MPU.Z30.E11.BE0.XD20.1

Suitable Machines:

Passend für Maschine:

XD12	XD16 III H	XD20	STL38 H	STL35 H(Y3)
XD12 II	XD16 H	XD20 M	STL38 H(Y3)	
XD12 III H	XD16 V	XD26 H	STL42 H	
XD12 III J	XD16 II	XE12 J	STL42 NH	
XD16 III J	XD20 V	XE16 J	STL32 H(Y3)	

Hanwha

Axial Bohr- und Fräskopf
Axial drilling and milling head

WG 35

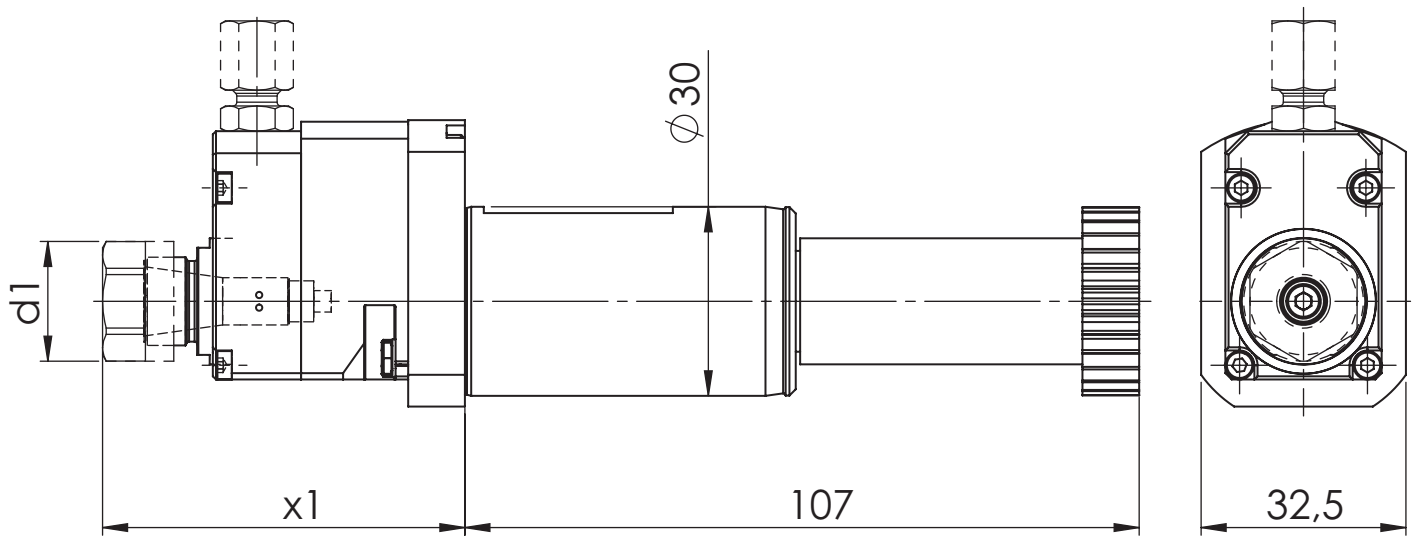
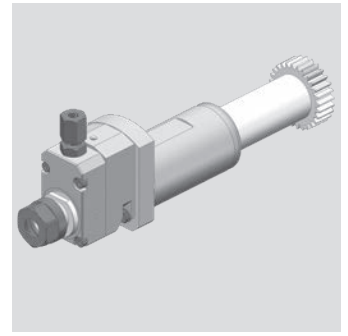

[mm]	[mm]	Spindle	[Nm]	[rpm]		Outside cooling	Internal cooling	[bar]	Order no.
d1	x1	Spindel	T max	n max	i	Aussenkühlung	Innenkühlung	p	Bestellnummer
19	51,2	ER11	2	32.000	1:4				MPU.Z30.E11.BA0.XD20.2
19	57,5	ER11	2	32.000	1:4		x	80	MPU.Z30.E11.BE0.XD20.2

Suitable Machines:

Passend für Maschine:

XD20 II H	XD26 II H	XE20 H	XE26 H	XE35 H
XD20 II N	XD26 II N	XE20 NH	XE26 NH	XE35 NH
XD20 II NH	XD26 II NH	XE20 J	XE26 J	XE35 J
XD20 II M	XD26 II M	XE20 Ne	XE26 Ne	XE35 Ne

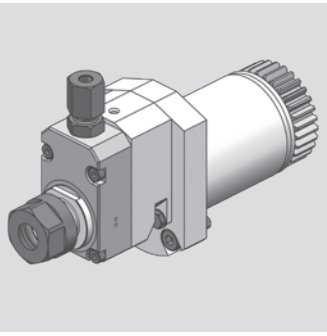

Hanwha

Axial Bohr- und Fräskopf
Axial drilling and milling head

WG 35

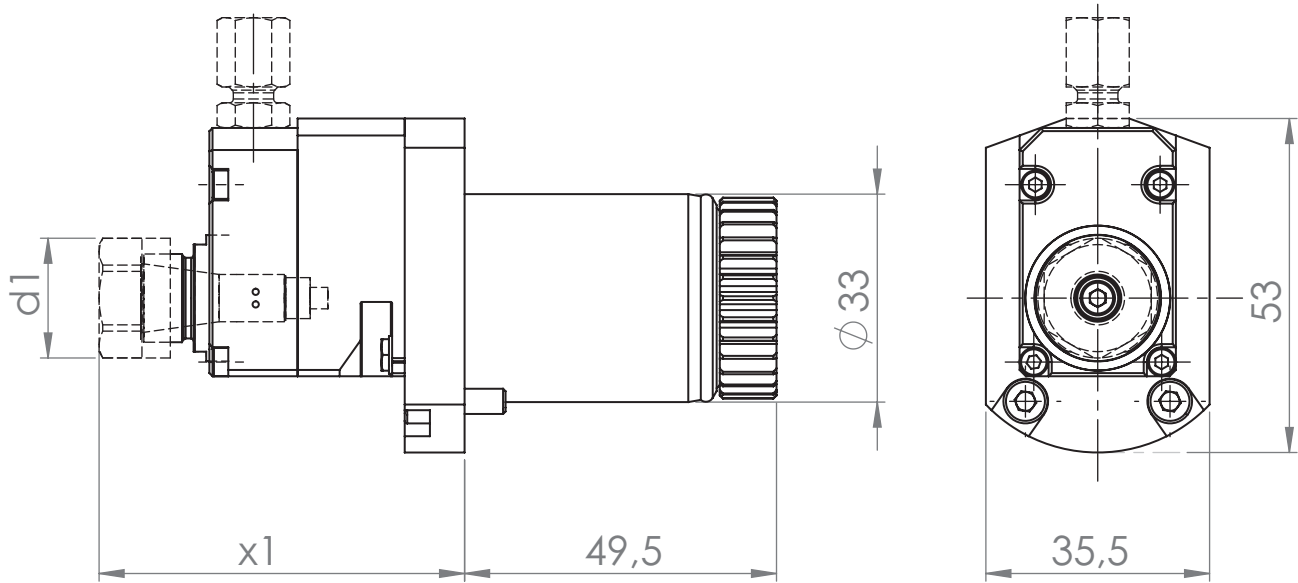

[mm]	[mm]	Spindle	[Nm]	[rpm]		Outside cooling	Internal cooling	[bar]	Order no.
d1	x1	Spindel	T max	n max	i	Aussenkühlung	Innenkühlung	p	Bestellnummer
19	51,7	ER11	2	32.000	1:4				MPU.Z33.E11.BA0.XD20.2
19	58	ER11	2	32.000	1:4		x	80	MPU.Z33.E11.BE0.XD20.2

Suitable Machines:

Passend für Maschine:

XD20 II H	XD26 II H	XE20 H	XE26 H
XD20 II N	XD26 II N	XE20 NH	XE26 NH
XD20 II NH	XD26 II NH	XE20 J	XE26 J
XD20 II M	XD26 II M	XE20 Ne	XE26 Ne

Hanwha

Axial Bohr- und Fräskopf
Axial drilling and milling head

WG 35

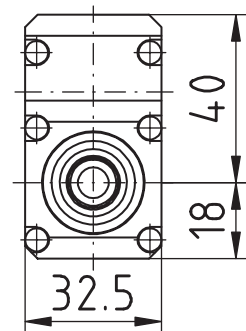
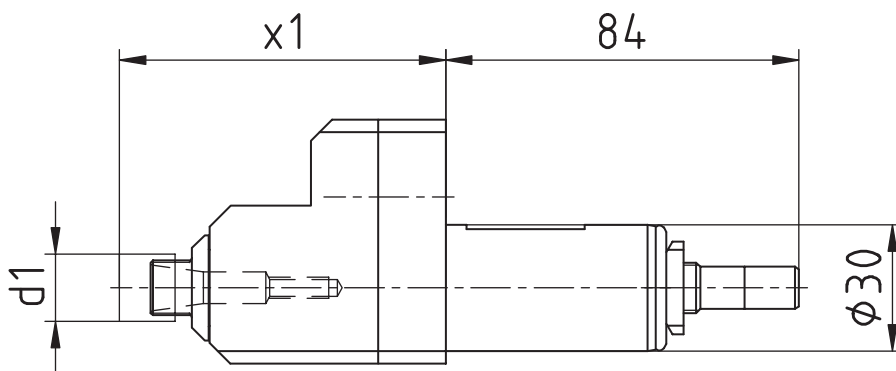
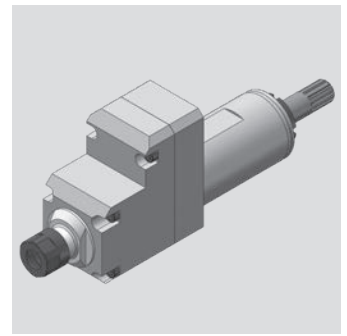

[mm]	[mm]	Spindle	[Nm]	[rpm]		Outside cooling	Internal cooling	[bar]	Order no.
d1	x1	Spindel	T max	n max	i	Aussenkühlung	Innenkühlung	p	Bestellnummer
16	77,6	ER11 MINI	3	15.000	1:3				MPU.Z30.E11.BA0.XD20

Suitable Machines:

Passend für Maschine:

XD12 III H	XD16 III H	XD20	STL38 H	STL35 H(Y3)
XD12 III J	XD16 H	XD20 M	STL38 H(Y3)	
XD12	XD16 V	XD26 H	STL42 H	
XD12 II	XD16 II	XE12 J	STL42 NH	
XD16 III J	XD20 V	XE16 J	STL32 H(Y3)	

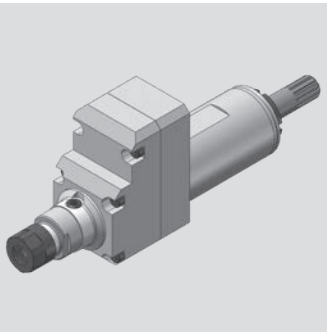

Hanwha

Axial Bohr- und Fräskopf
Axial drilling and milling head

WG 35

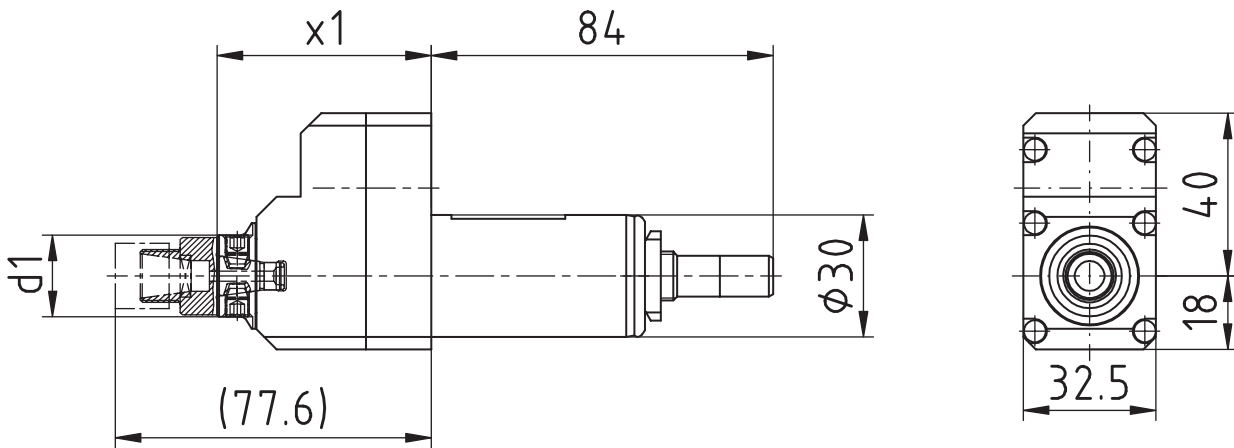

[mm]	[mm]	Spindle	[Nm]	[rpm]		Outside cooling	Internal cooling	[bar]	Order no.
d1	x1	Spindel	T max	n max	i	Aussenkühlung	Innenkühlung	p	Bestellnummer
20	52,6	WF-Micro	3	15.000	1:3				MPU.Z30.WFM.BA0.XD20

Suitable Machines:

Passend für Maschine:

XD12 III H	XD16 III H	XD20	STL38 H	STL35 H(Y3)
XD12 III J	XD16 H	XD20 M	STL38 H(Y3)	
XD12	XD16 V	XD26 H	STL42 H	
XD12 II	XD16 II	XE12 J	STL42 NH	
XD16 III J	XD20 V	XE16 J	STL32 H(Y3)	

Spare Parts

Ersatzteile

threaded taper pin	Quantity	Tightening torque [Nm]	Order no.
Kegelgewindestift	Anzahl	Anzugsmoment [Nm]	Bestellnummer
M6X0,75	2	4	WFS.M6X0,75.TORX15PLUS

Maier

Axial Bohr- und Fräskopf
Axial drilling and milling head

WG 35

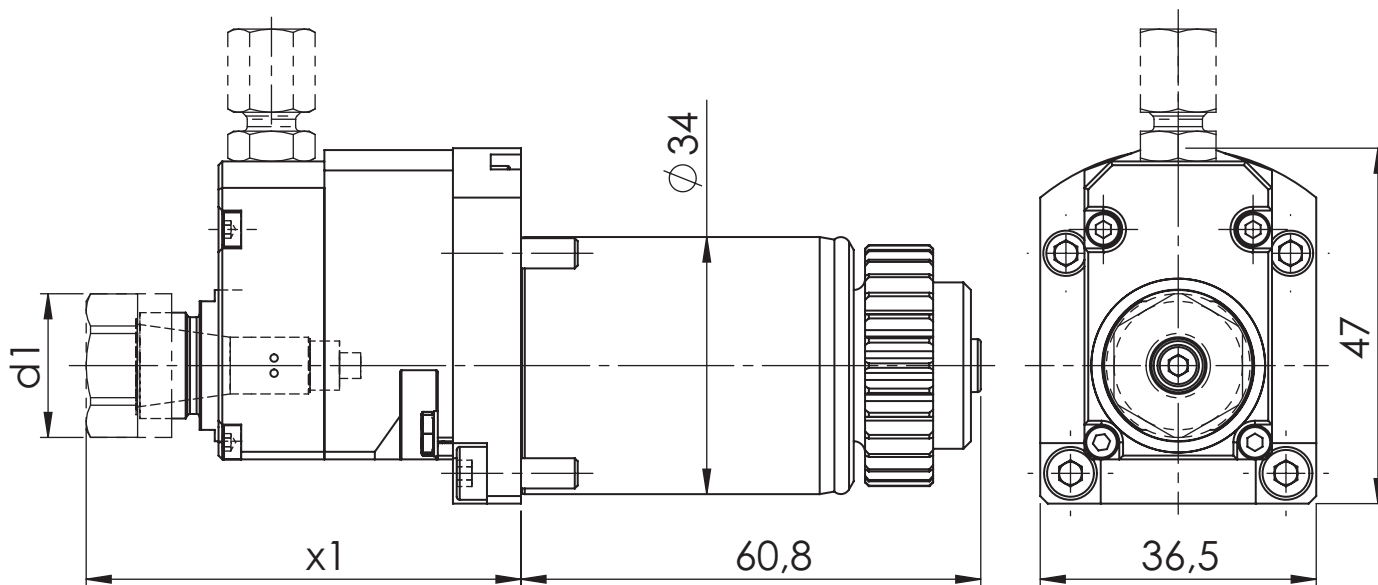
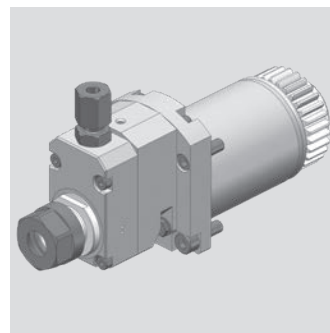

[mm]	[mm]	Spindle	[Nm]	[rpm]		Outside cooling	Internal cooling	[bar]	Order no.
d1	x1	Spindel	T max	n max	i	Aussenkühlung	Innenkühlung	p	Bestellnummer
19	51,2	ER11	2	32.000	1:4				MPU.Z34.E11.BA0.MAIS4
19	57,5	ER11	2	32.000	1:4		x	80	MPU.Z34.E11.BE0.MAIS4

Suitable Machines:

Passend für Maschine:

ML-PROLINE A/B
ML-PROLINE C/C5
ML-PROLINE D/DY

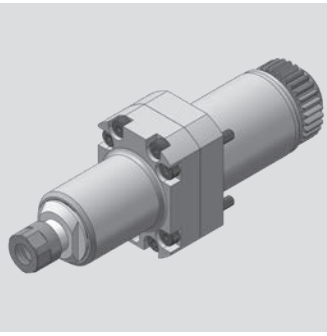

Maier

Axial Bohr- und Fräskopf
Axial drilling and milling head

WG 35

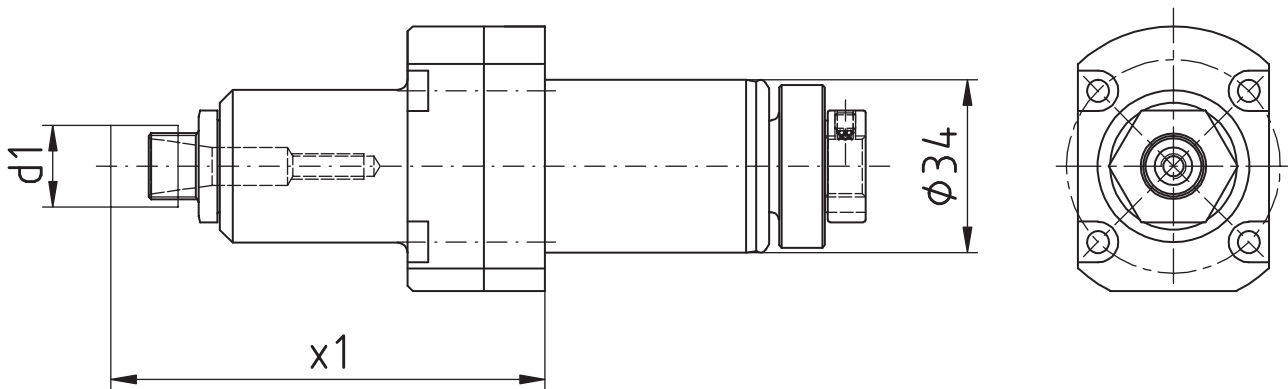

[mm]	[mm]	Spindle	[Nm]	[rpm]		Outside cooling	Internal cooling	[bar]	Order no.
d1	x1	Spindel	T max	n max	i	Aussenkühlung	Innenkühlung	p	Bestellnummer
16	85,4	ER11 MINI	3	24.000	1:2,4				MPU.Z34.E11.BA0.MAIS

Suitable Machines:

Passend für Maschine:

ML-PROLINE A/B
ML-PROLINE C/C5
ML-PROLINE D/DY

Maier

Axial Bohr- und Fräskopf
Axial drilling and milling head

WG 35

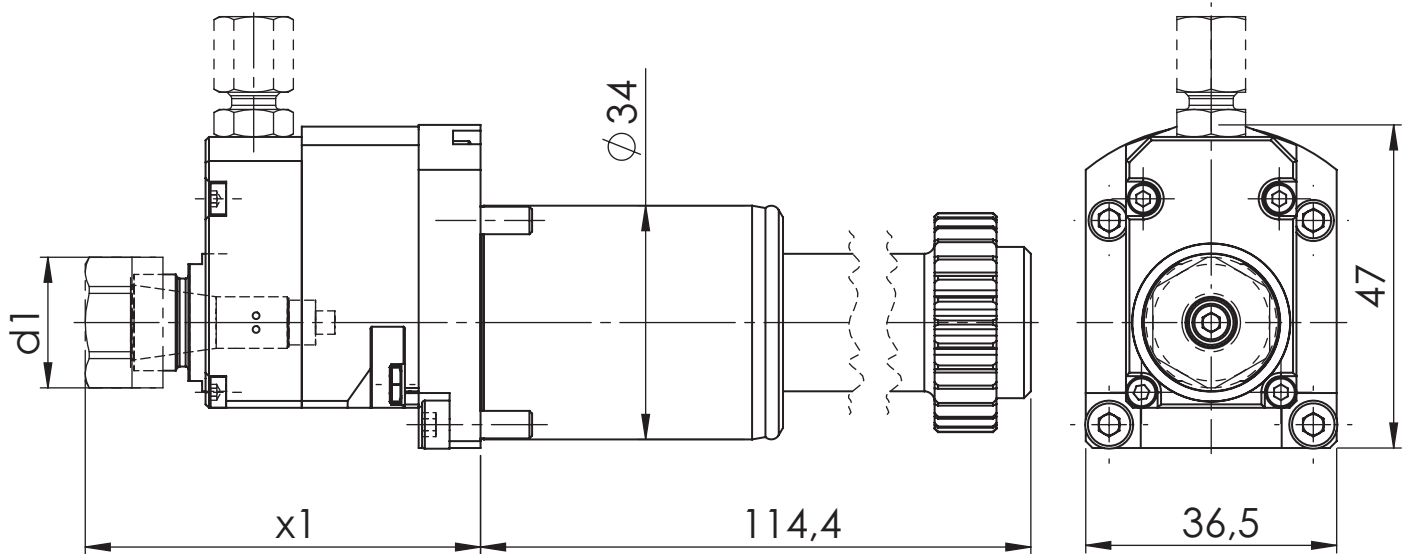
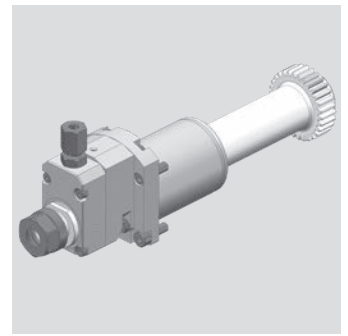

[mm]	[mm]	Spindle	[Nm]	[rpm]		Outside cooling	Internal cooling	[bar]	Order no.
d1	x1	Spindel	T max	n max	i	Aussenkühlung	Innenkühlung	p	Bestellnummer
19	51,2	ER11	2	32.000	1:4				MPU.Z34.E11.BA0.MAISL4
19	57,5	ER11	2	32.000	1:4		x	80	MPU.Z34.E11.BE0.MAISL4

Suitable Machines:
Passend für Maschine:

Maier C6
Maier-PROLINE linear

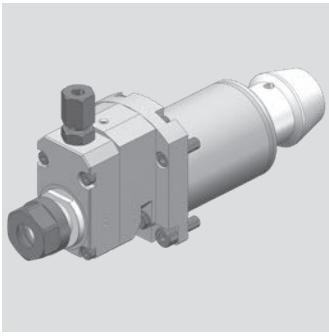

Maier

Axial Bohr- und Fräskopf
Axial drilling and milling head

WG 35

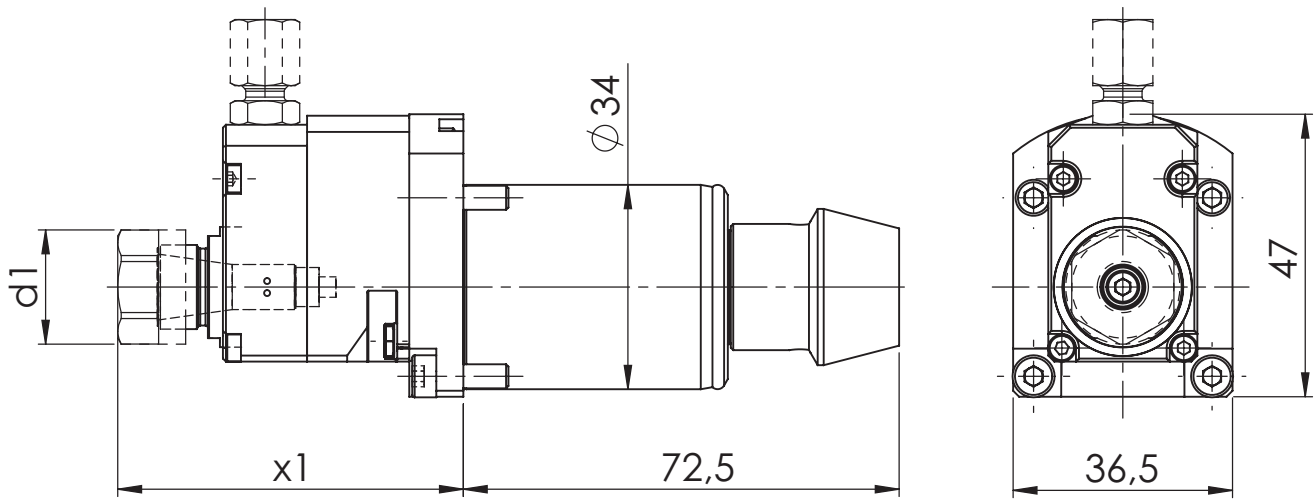

[mm]	[mm]	Spindle	[Nm]	[rpm]		Outside cooling	Internal cooling	[bar]	Order no.
d1	x1	Spindel	T max	n max	i	Aussenkühlung	Innenkühlung	p	Bestellnummer
19	51,2	ER11	2	32.000	1:4				MPU.Z34.E11.BA0.MAIK4
19	57,5	ER11	2	32.000	1:4		x	80	MPU.Z34.E11.BE0.MAIK4

Suitable Machines:

Passend für Maschine:

ML-PROLINE E

ML-PROLINE F2/F4

Maier

Axial Bohr- und Fräskopf
Axial drilling and milling head

WG 35

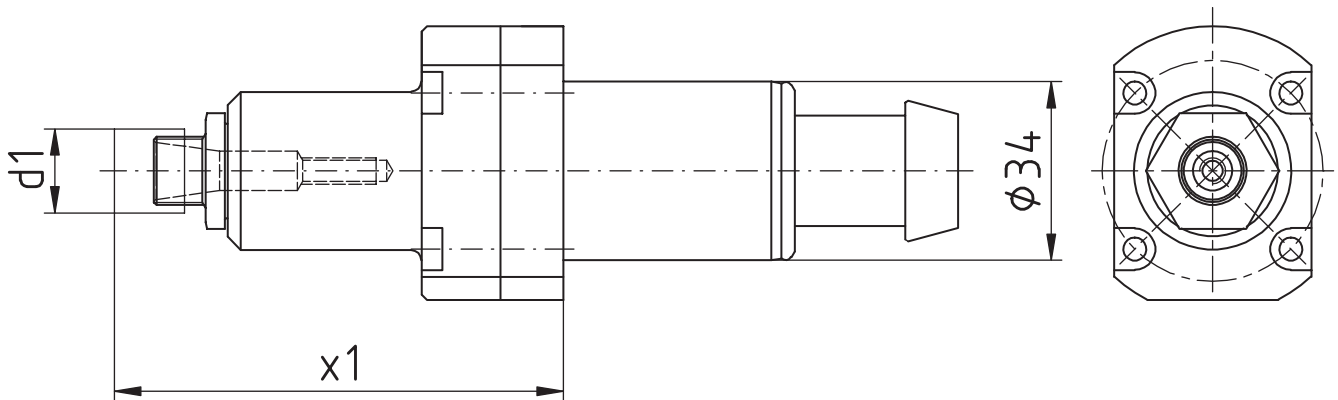
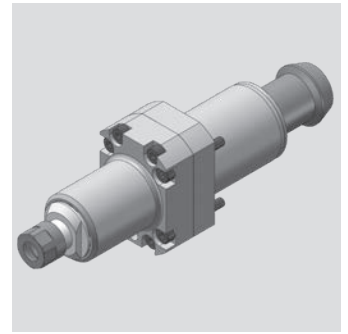

[mm]	[mm]	Spindle	[Nm]	[rpm]		Outside cooling	Internal cooling	[bar]	Order no.
d1	x1	Spindel	T max	n max	i	Aussenkühlung	Innenkühlung	p	Bestellnummer
16	85,4	ER11 MINI	3	24.000	1:2,4				MPU.Z34.E11.BA0.MAIK

Suitable Machines:
Passend für Maschine:

ML-PROLINE E
ML-PROLINE F2/F4

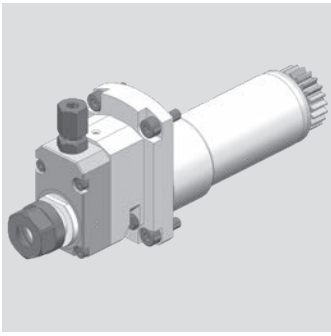

Nomura

Axial Bohr- und Fräskopf
Axial drilling and milling head

WG 35

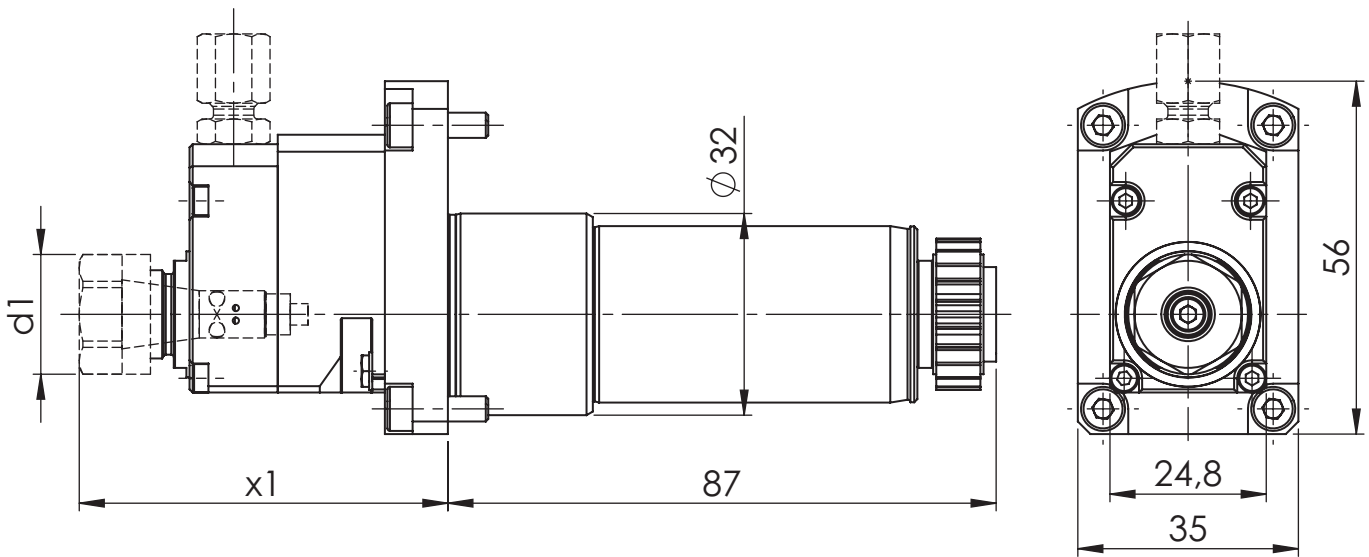

[mm]	[mm]	Spindle	[Nm]	[rpm]		Outside cooling	Internal cooling	[bar]	Order no.
d1	x1	Spindel	T max	n max	i	Aussenkühlung	Innenkühlung	p	Bestellnummer
19	58,5	ER11	2	32.000	1:4				MPU.Z32.E11.BA0.NO.1
19	58,5	ER11	2	32.000	1:4		x	80	MPU.Z32.E11.BE0.NO.1

Suitable Machines:

Passend für Maschine:

NN20J2	NN20JS
NN20J3	NN20U5
NN20J	NN10J

Star

Axial Bohr- und Fräskopf
Axial drilling and milling head

WG 35

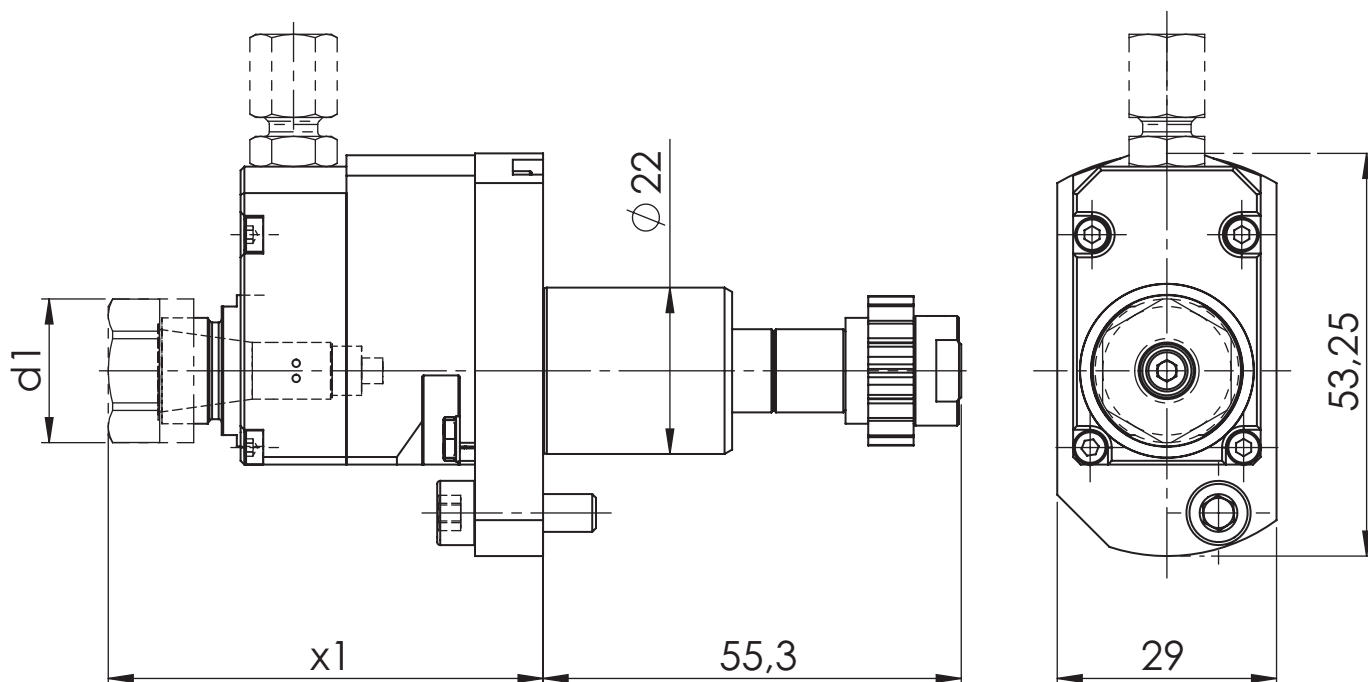
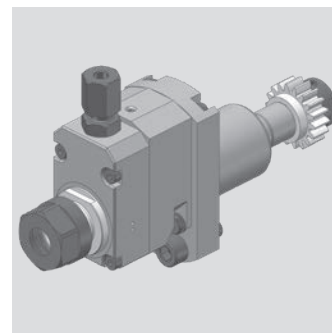

[mm]	[mm]	Spindle	[Nm]	[rpm]		Outside cooling	Internal cooling	[bar]	Order no.
d1	x1	Spindel	T max	n max	i	Aussenkühlung	Innenkühlung	p	Bestellnummer
19	51,2	ER11	2	32.000	1:4				MPU.Z22.E11.BA0.101-52
19	57,5	ER11	2	32.000	1:4		x	80	MPU.Z22.E11.BE0.101-52

Suitable Machines:
Passend für Maschine:

SW-12RII

Similar to OEM no.
Ähnlich OEM Nr.

101-52

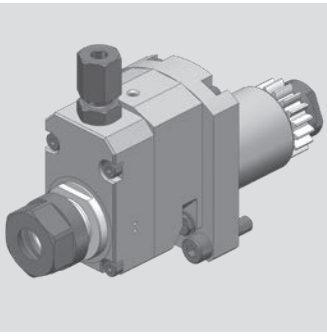

Star

Axial Bohr- und Fräskopf
Axial drilling and milling head

WG 35

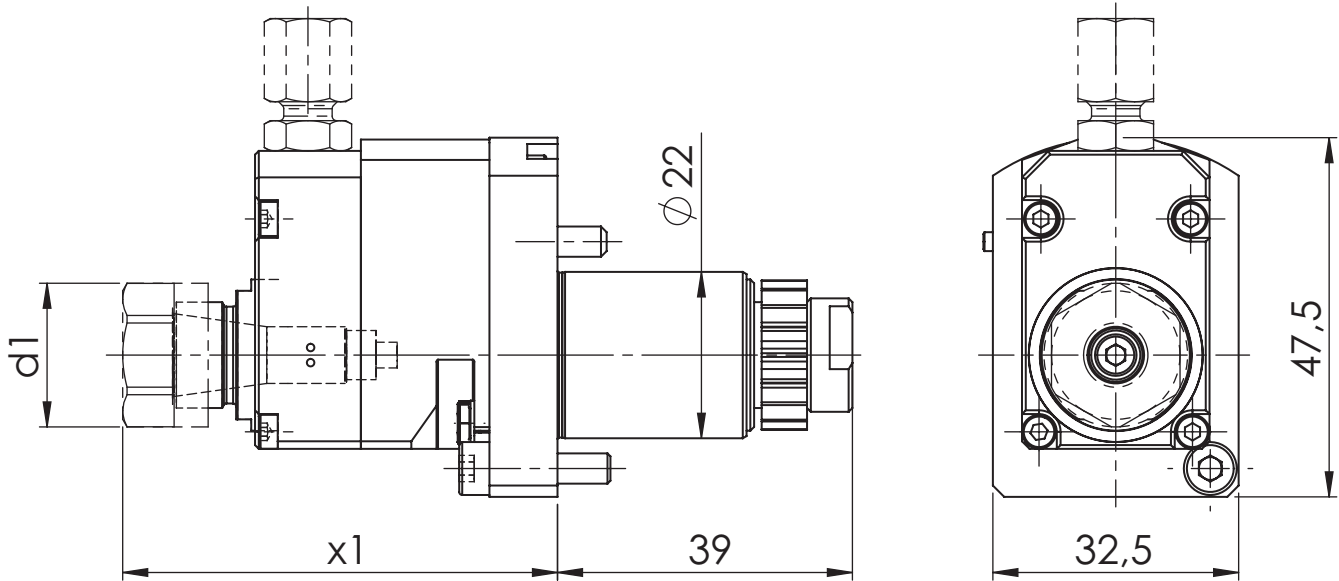

[mm]	[mm]	Spindle	[Nm]	[rpm]		Outside cooling	Internal cooling	[bar]	Order no.
d1	x1	Spindel	T max	n max	i	Aussenkühlung	Innenkühlung	p	Bestellnummer
19	51,2	ER11	2	32.000	1:4				MPU.Z22.E11.BA0.OR-61
19	57,5	ER11	2	32.000	1:4		x	80	MPU.Z22.E11.BE0.OR-61

Suitable Machines:

Passend für Maschine:

SW-12R11 SR-20RIV SV-20R
SW20 SR-32JII-A SR-38 (TypeA/B)
SB-12/20R SR-32JII-B

Similar to OEM no.

Ähnlich OEM Nr.

OR1-61

Star

Axial Bohr- und Fräskopf
Axial drilling and milling head

WG 35

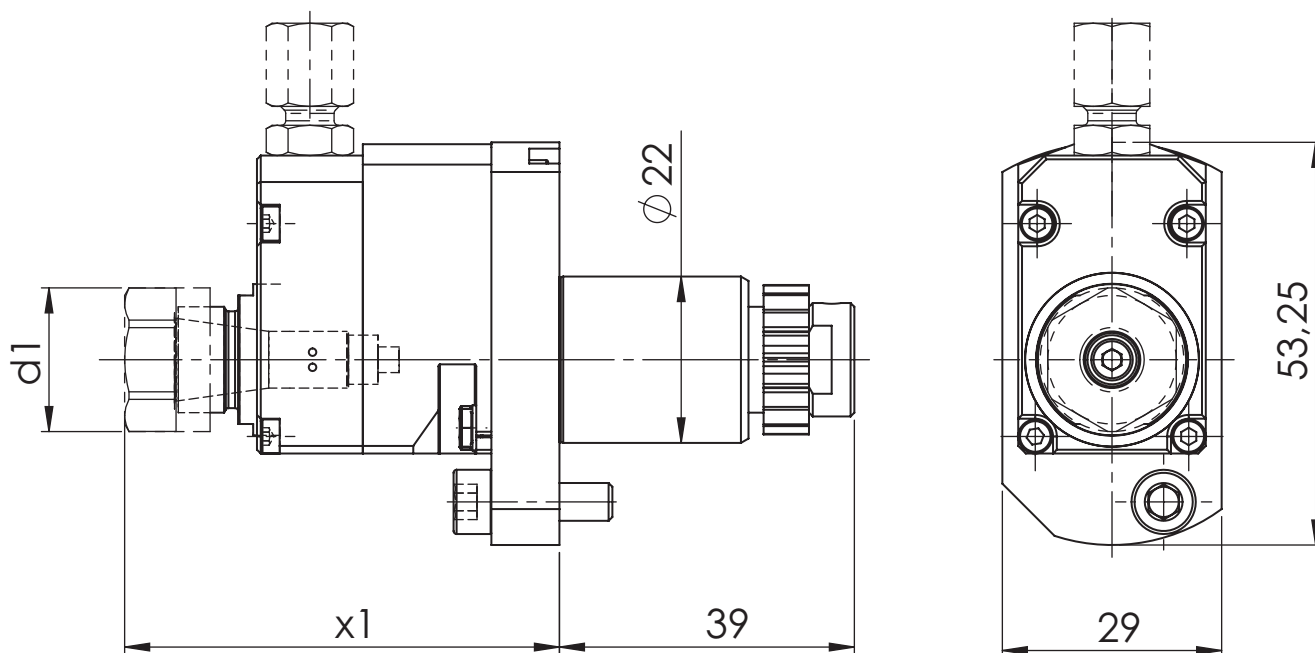
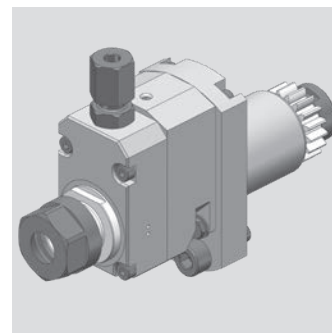

[mm]	[mm]	Spindle	[Nm]	[rpm]		Outside cooling	Internal cooling	[bar]	Order no.
d1	x1	Spindel	T max	n max	i	Aussenkühlung	Innenkühlung	p	Bestellnummer
19	51,2	ER11	2	32.000	1:4				MPU.Z22.E11.BA0.SR20
19	57,5	ER11	2	32.000	1:4		x	80	MPU.Z22.E11.BE0.SR20

Suitable Machines:

Passend für Maschine:

SW-12RII	SR-20J/JN/JII-A	SR-20RIV
ECAS-12/20	SR-20RIII	SR-32J/JN
SR-10J	SR-20RII	SR-32JII-A

Similar to OEM no.

Ähnlich OEM Nr.

101-76

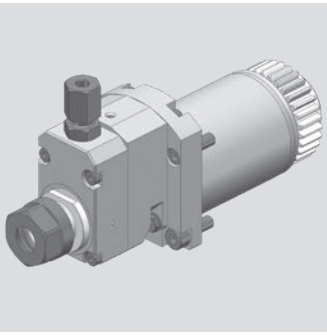

Star

Axial Bohr- und Fräskopf
Axial drilling and milling head

WG 35

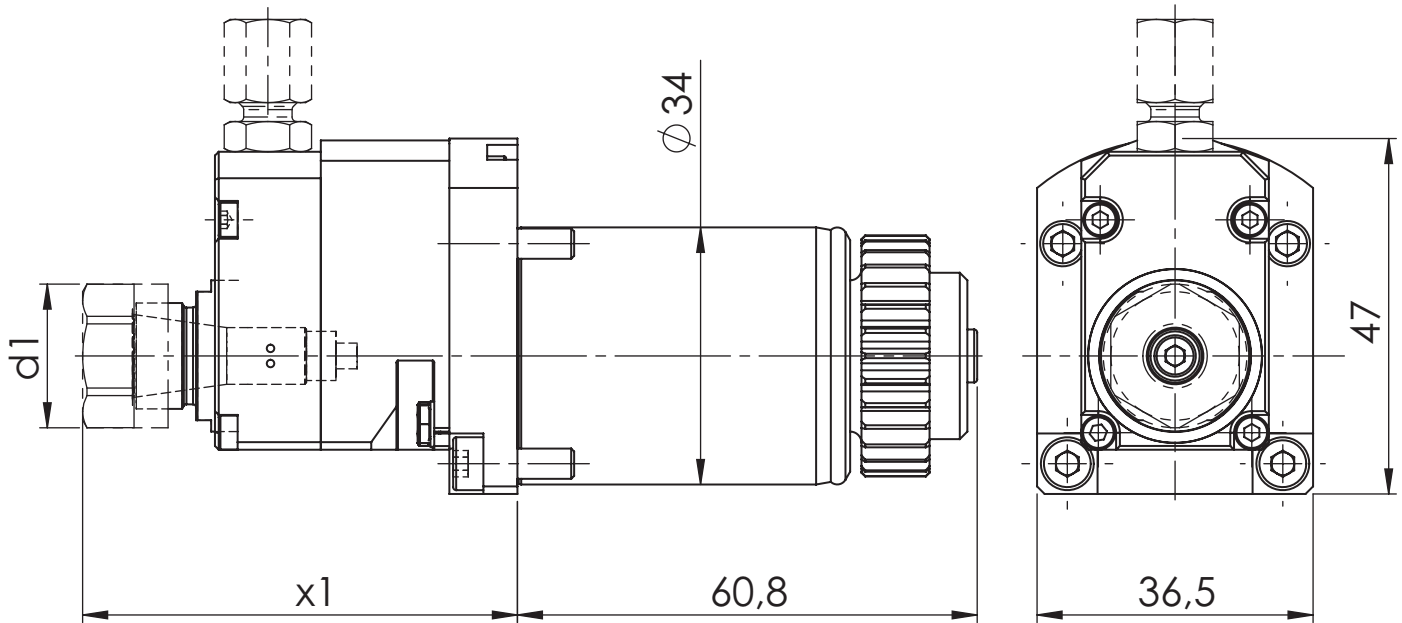

[mm]	[mm]	Spindle	[Nm]	[rpm]		Outside cooling	Internal cooling	[bar]	Order no.
d1	x1	Spindel	T max	n max	i	Aussenkühlung	Innenkühlung	p	Bestellnummer
19	51,2	ER11	2	32.000	1:4				MPU.Z34.E11.BA0.SR20I4
19	57,5	ER11	2	32.000	1:4		x	80	MPU.Z34.E11.BE0.SR20I4

Suitable Machines:

Passend für Maschine:

ECAS-12/20	SR-20RII	SR-32JII-B	SV-32JII
SB-12/20R	SR-20RIV	SV-12	SV-38R
SR-20J/JN/JII-A	SR-32J/JN	SV-20	SW-20
SR-20RIII	SR-32JII-A	SV-32	

Star

Axial Bohr- und Fräskopf
Axial drilling and milling head

WG 35

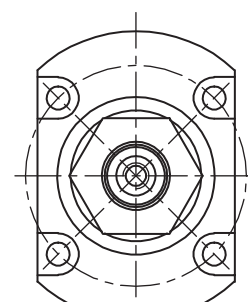
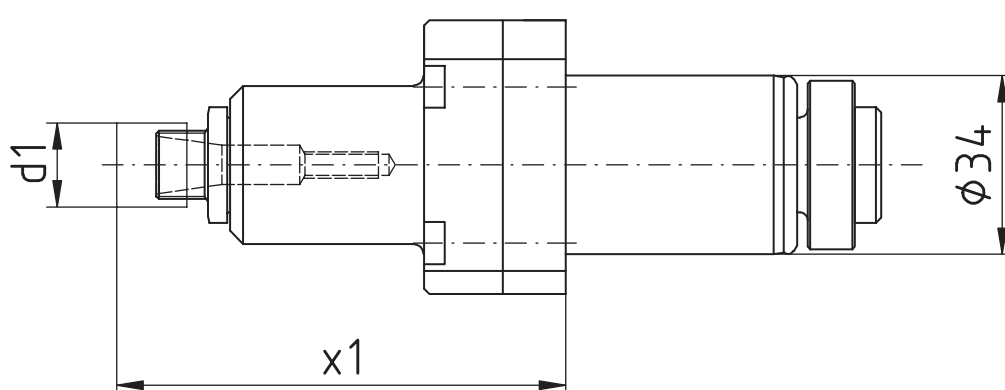
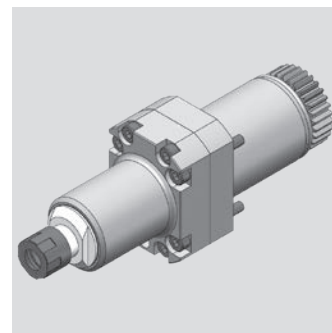

[mm]	[mm]	Spindle	[Nm]	[rpm]		Outside cooling	Internal cooling	[bar]	Order no.
d1	x1	Spindel	T max	n max	i	Aussenkühlung	Innenkühlung	p	Bestellnummer
16	85,4	ER11 MINI	3	19.200	1:2,4				MPU.Z34.E11.BA0.SR20

Suitable Machines:

Passend für Maschine:

ECAS-12/20	SR-20RII	SR-32JII-B	SV-32JII
SB-12/20R	SR-20RIV	SV-12	SV-38R
SR-20J/JN/JII-A	SR-32J/JN	SV-20	SW-20
SR-20RIII	SR-32JII-A	SV-32	

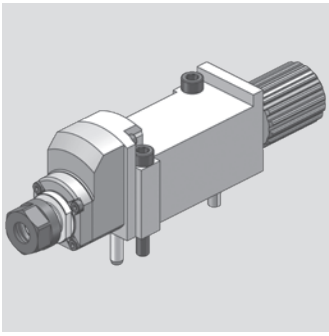

Tornos

Axial Bohr- und Fräskopf
Axial drilling and milling head

WG 35

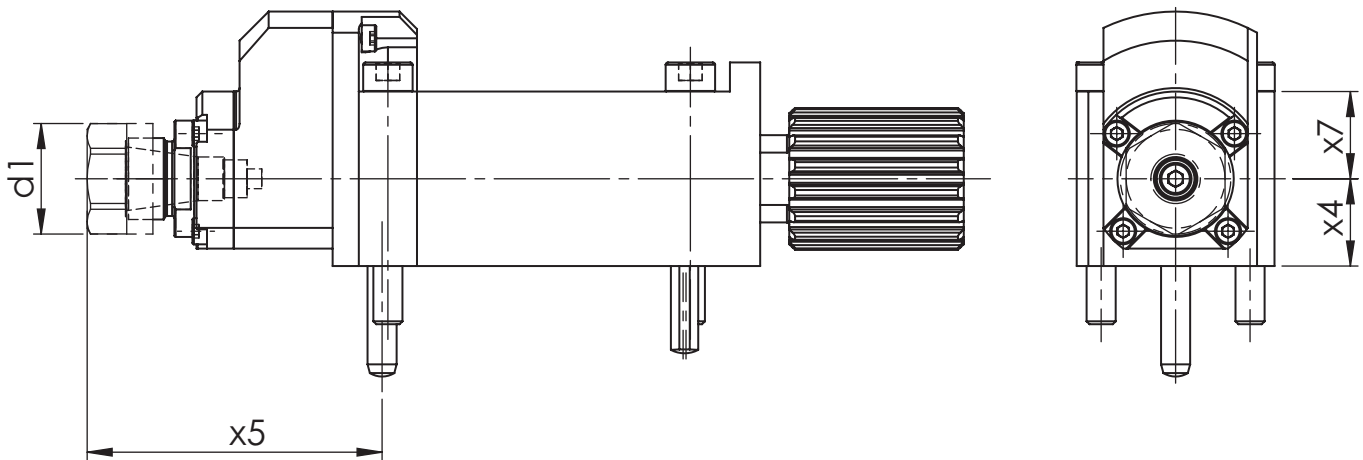

[mm]	[mm]	[mm]	[mm]	Spindle	[Nm]	[rpm]		Outside cooling	Internal cooling	[bar]	Order no.
d1	x4	x5	x7	Spindel	T max	n max	i	Aussenkühlung	Innenkühlung	p	Bestellnummer
19	15	50,7	15	ER11	2	32.000	1:4				MPU.TO.0115.DE10.4

Suitable Machines:

Passend für Maschine:

DECO 10
EvoDECO 10

Tornos

Axial Bohr- und Fräskopf
Axial drilling and milling head

WG 35

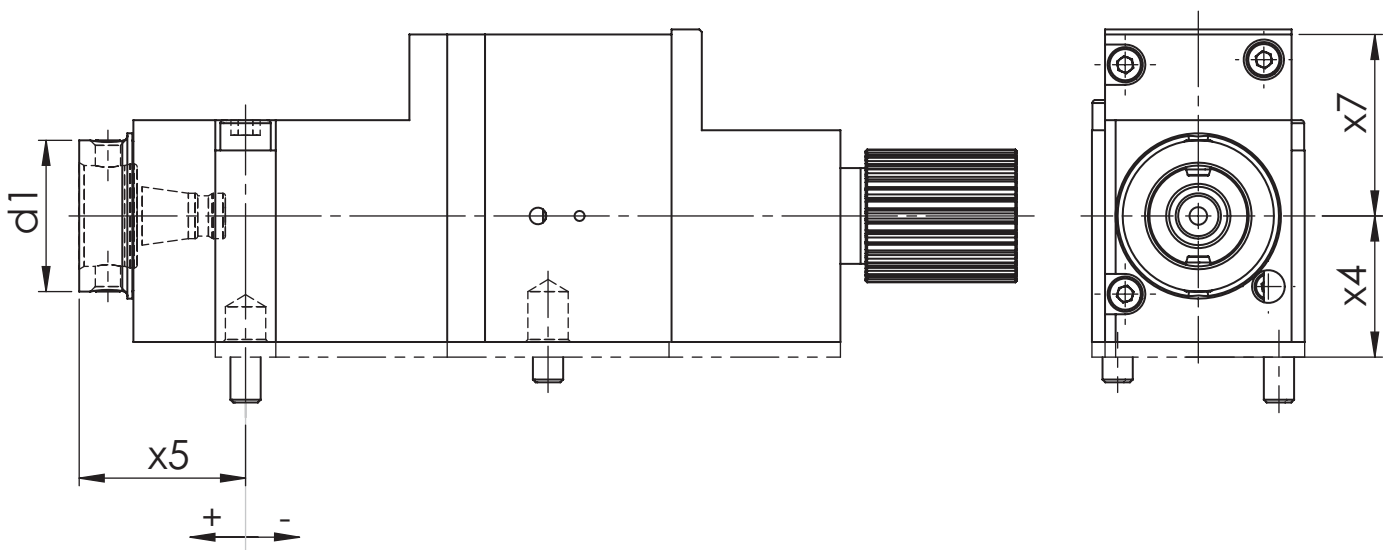
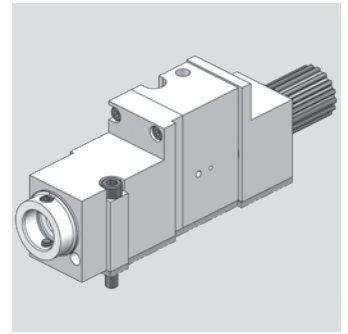

[mm]	[mm]	[mm]	[mm]	Spindle	[Nm]	[rpm]		Outside cooling	Internal cooling	[bar]	Order no.
d1	x4	x5	x7	Spindel	T max	n max	i	Aussenkühlung	Innenkühlung	p	Bestellnummer
30	28	17	36	WFB 20-12	3	24.000	1:3				MPU.TO.0130.DE13
30	28	-7	36	WFB 20-12	3	24.000	1:3		x	80	MPU.TO.0100.DE13H
30	28	17	36	WFB 20-12	3	24.000	1:3		x	80	MPU.TO.0110.DE13H
30	28	33	36	WFB 20-12	3	24.000	1:3		x	80	MPU.TO.0120.DE13H

Suitable Machines:

Passend für Maschine:

DECO 13	EvoDECO 16/10
DECO 16	EvoDECO 16/8

Spare Parts

Ersatzteile

threaded taper pin	Quantity	Tightening torque [Nm]	Order no.
Kegelgewindestift	Anzahl	Anzugsmoment [Nm]	Bestellnummer
M6X0,75	2	4	WFS.M6X0,75.TORX15PLUS

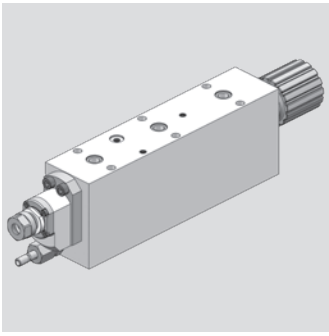

Tornos

Axial Bohr- und Fräskopf
Axial drilling and milling head

WG 35

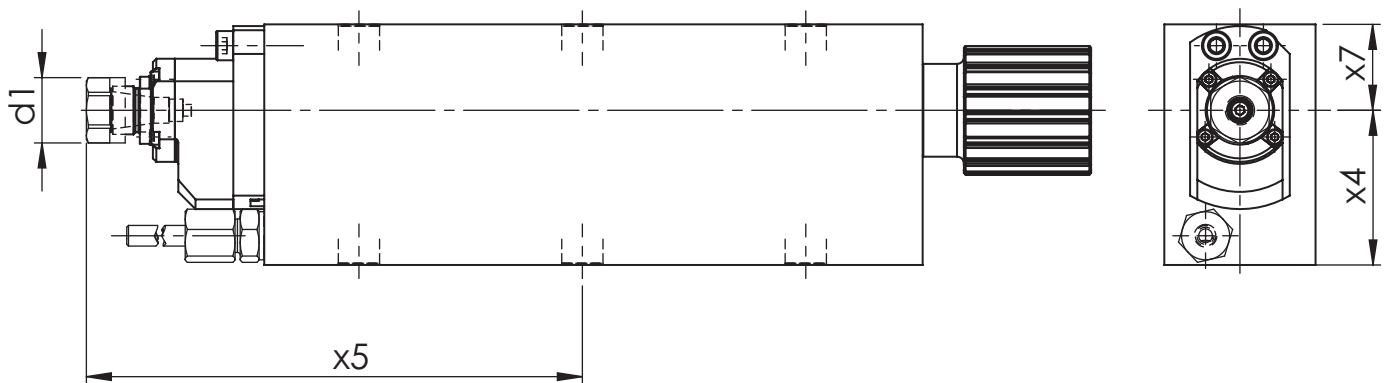

[mm]	[mm]	[mm]	[mm]	Spindle	[Nm]	[rpm]		Outside cooling	Internal cooling	[bar]	Order no.
d1	x4	x5	x7	Spindel	T max	n max	i	Aussenkühlung	Innenkühlung	p	Bestellnummer
19	45	110,3	25	ER11	2	32.000	1:4	x			MPU.TO.0110.DE20.I4
19	45	144,3	25	ER11	2	32.000	1:4	x			MPU.TO.0120.DE20.I4

Suitable Machines:

Passend für Maschine:

DECO 20/26 EvoDECO 32
DECO 26a
EvoDECO 20

Tornos

Axial Bohr- und Fräskopf
Axial drilling and milling head

WG 35

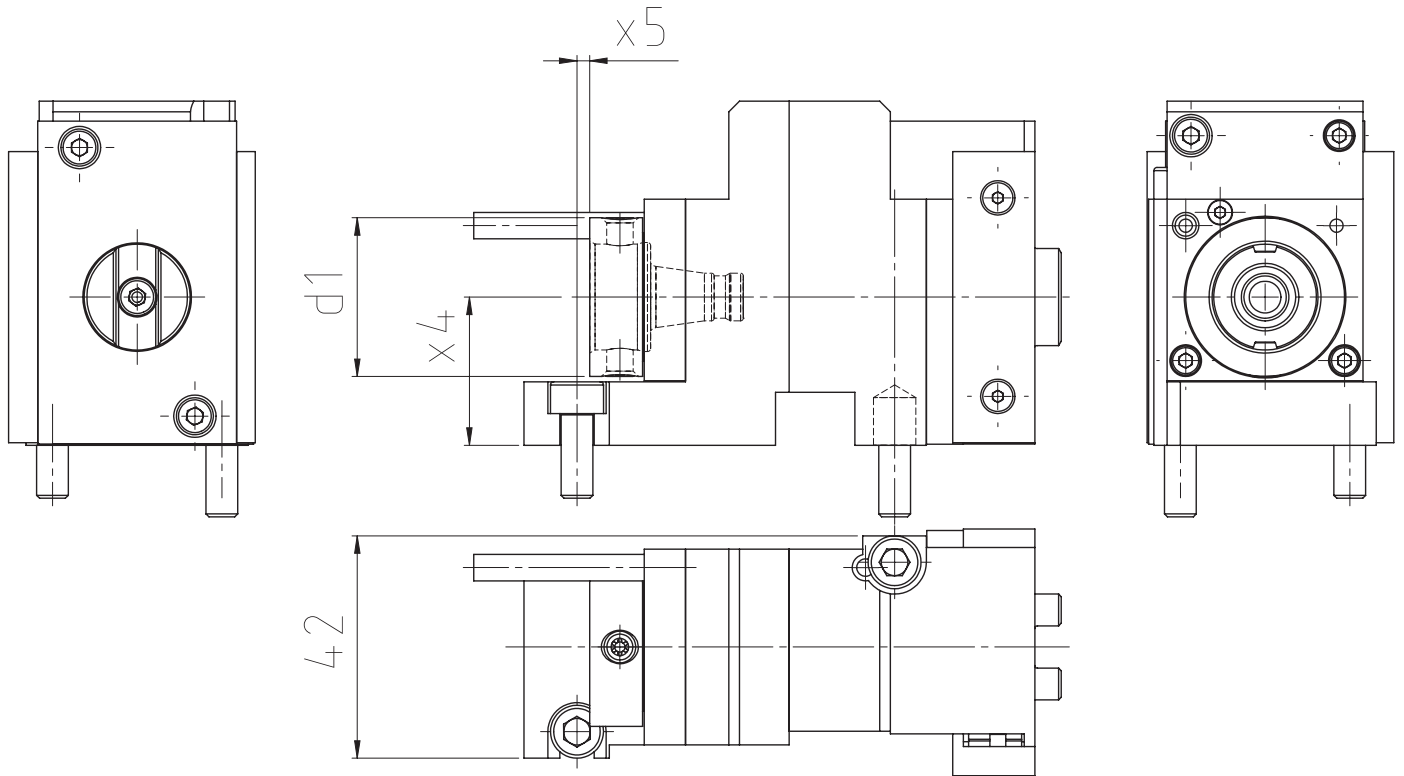
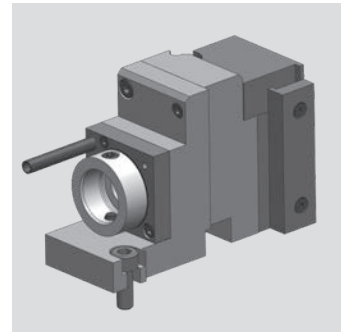

[mm]	[mm]	[mm]	Spindle	[Nm]	[rpm]		Outside cooling	Internal cooling	[bar]	Order no.
d1	x4	x5	Spindel	T max	n max	i	Aussenkühlung	Innenkühlung	p	Bestellnummer
30	28	2,4	WFB 20-12	3	18.000	1:3	x			MPU.TO.B20.S28.DGST

Suitable Machines:
Passend für Maschine:

DT 13	GT 26	ST 26
DT 26	GT 32	
GT 13	GT 32B	

Spare Parts
Ersatzteile

threaded taper pin	Quantity	Tightening torque [Nm]	Order no.
Kegelgewindestift	Anzahl	Anzugsmoment [Nm]	Bestellnummer
M6X0,75	2	4	WFS.M6X0,75.TORX15PLUS

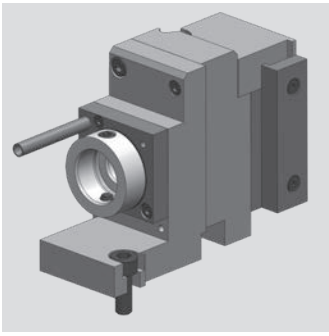

Tornos

Axial Bohr- und Fräskopf
Axial drilling and milling head

WG 35

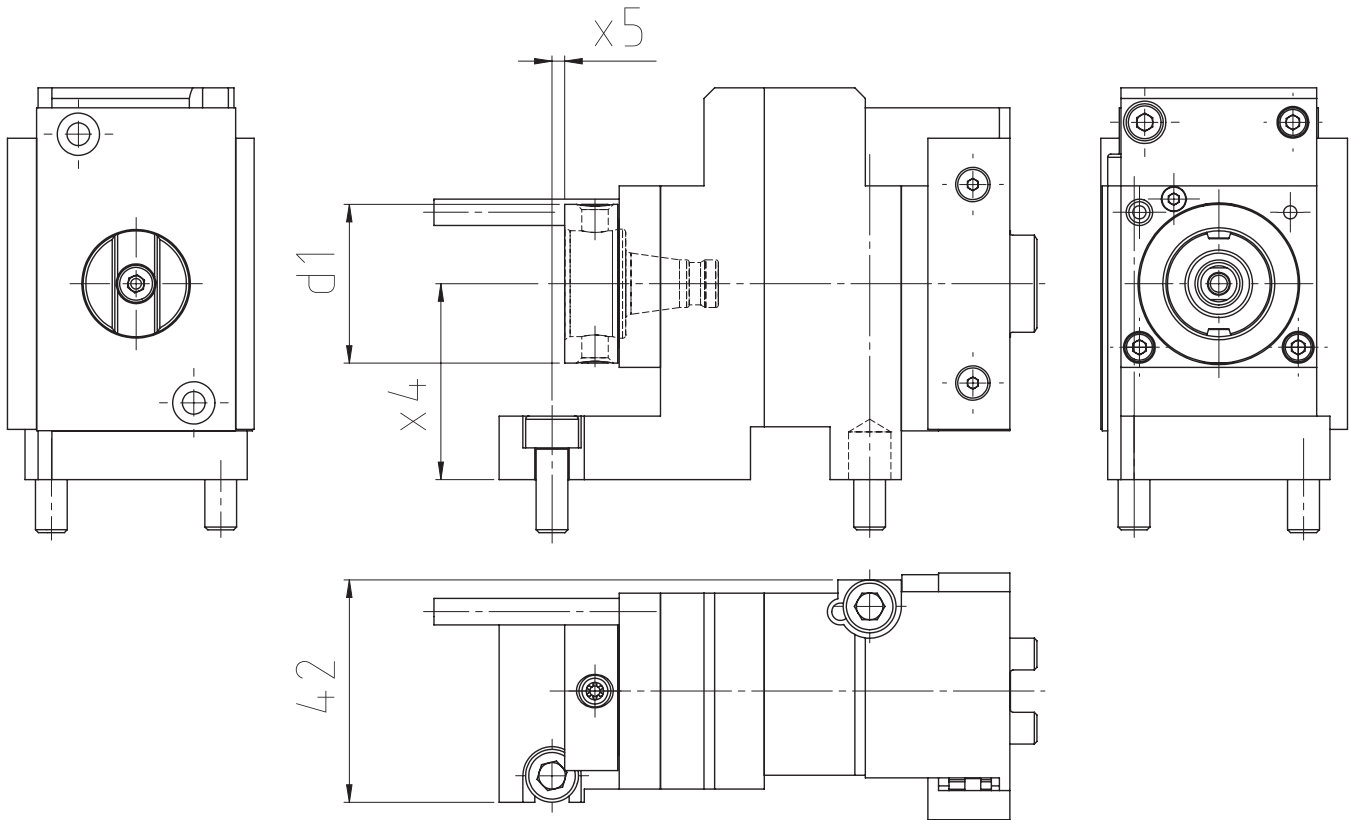

[mm]	[mm]	[mm]	Spindle	[Nm]	[rpm]		Outside cooling	Internal cooling	[bar]	Order no.
d1	x4	x5	Spindel	T max	n max	i	Aussenkühlung	Innenkühlung	p	Bestellnummer
30	37	2,4	WFB 20-12	3 Nm	18.000	1:3	x			MPU.TO.B20.S37.DGST

Suitable Machines:

Passend für Maschine:

DT 26	GT 32
GT 13	ST 26
GT 26	

Spare Parts

Ersatzteile

threaded taper pin	Quantity	Tightening torque [Nm]	Order no.
Kegelgewindestift	Anzahl	Anzugsmoment [Nm]	Bestellnummer
M6X0,75	2	4	WFS.M6X0,75.TORX15PLUS

Tsugami

Axial Bohr- und Fräskopf
Axial drilling and milling head

WG 35

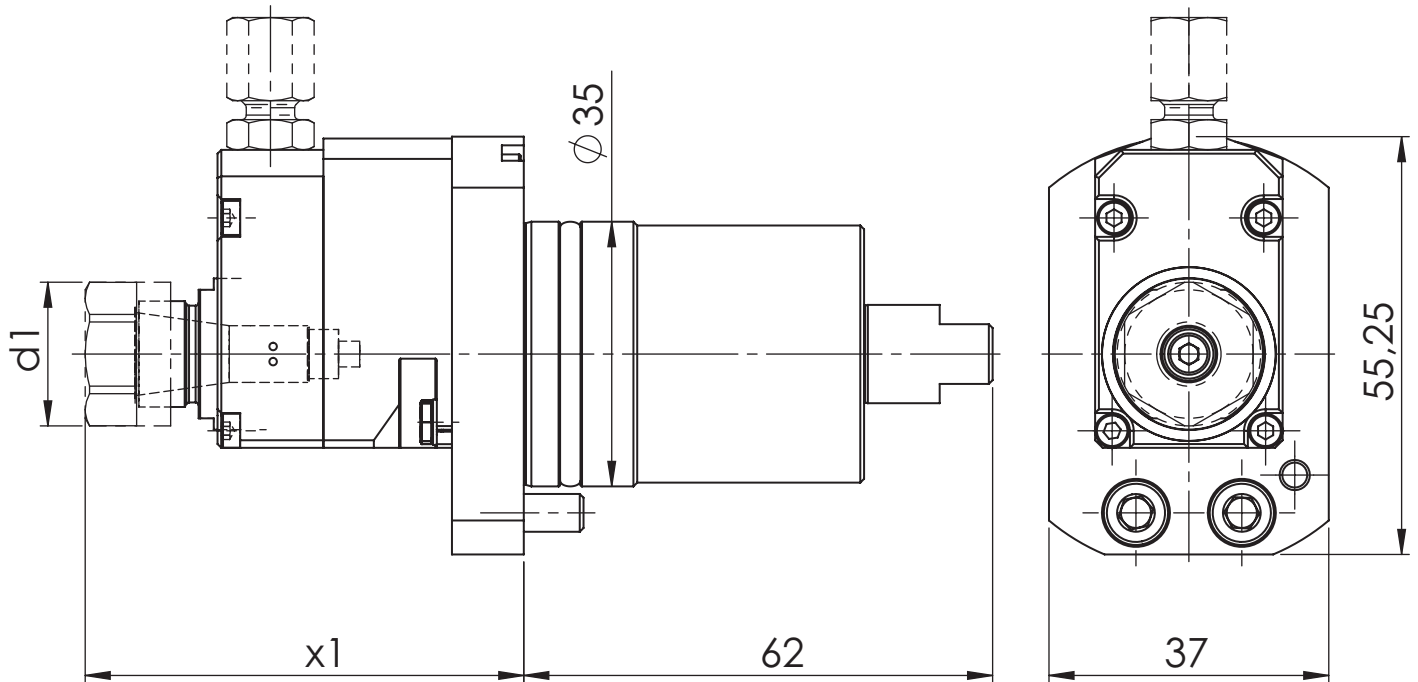
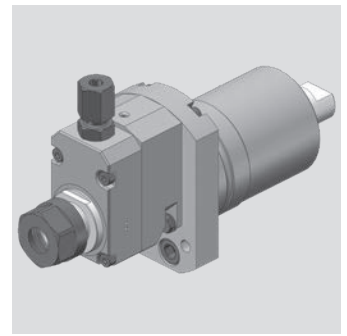

[mm]	[mm]	Spindle	[Nm]	[rpm]		Outside cooling	Internal cooling	[bar]	Order no.
d1	x1	Spindel	T max	n max	i	Aussenkühlung	Innenkühlung	p	Bestellnummer
19	51,7	ER11	2	32.000	1:4				MPU.Z35.E11.BA0.TSR.I4
19	58	ER11	2	32.000	1:4		x	80	MPU.Z35.E11.BE0.TSR.I4

Suitable Machines:

Passend für Maschine:

S205 E

S206 E

HS207

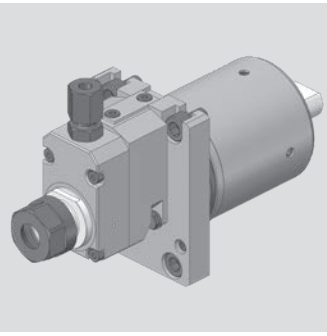

Tsugami

Axial Bohr- und Fräskopf
Axial drilling and milling head

WG 35

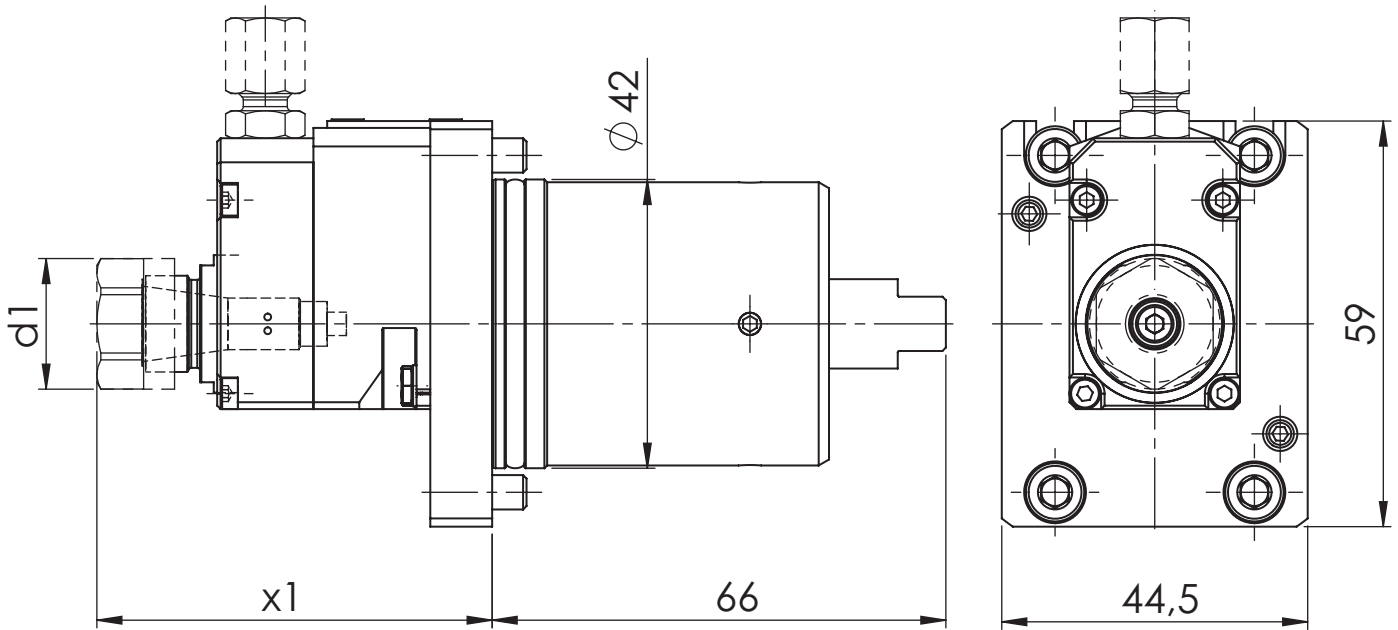

[mm]	[mm]	Spindle	[Nm]	[rpm]		Outside cooling	Internal cooling	[bar]	Order no.
d1	x1	Spindel	T max	n max	i	Aussenkühlung	Innenkühlung	p	Bestellnummer
19	51,2	ER11	2	32.000	1:4				MPU.Z42.E11.BA0.TSR.I4
19	57,5	ER11	2	32.000	1:4		x	80	MPU.Z42.E11.BE0.TSR.I4

Suitable Machines:

Passend für Maschine:

B0266	HS327	HS327 5AX	B0385 E
B0326E	B0325E	B0266 EII	B0266 EII
B0385	B0386 V	B0386	

Tsugami

Axial Bohr- und Fräskopf
Axial drilling and milling head

WG 35

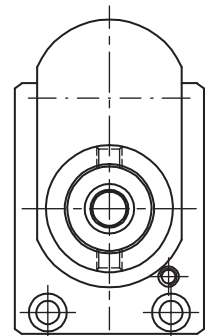
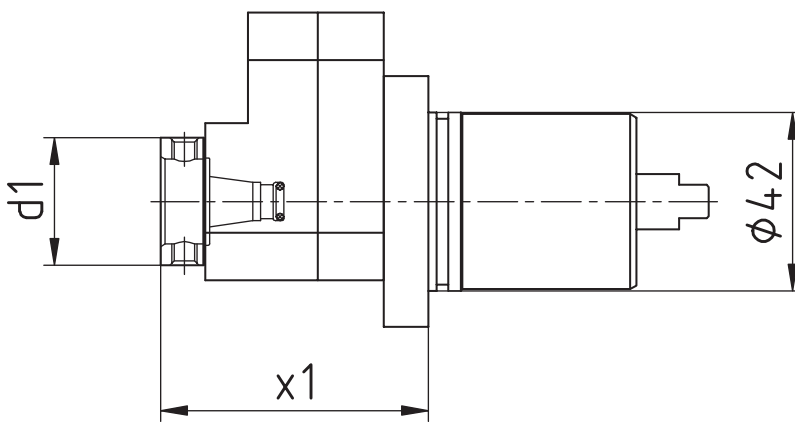
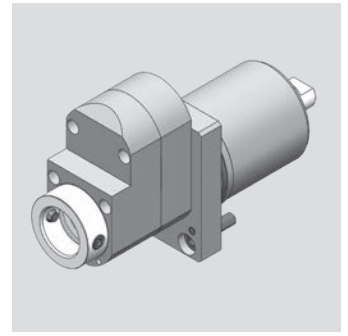

[mm]	[mm]	Spindle	[Nm]	[rpm]		Outside cooling	Internal cooling	[bar]	Order no.
d1	x1	Spindel	T max	n max	i	Aussenkühlung	Innenkühlung	p	Bestellnummer
30	63	WFB 20-12	3	24.000	1:3				MPU.Z42.B20.BA0.TS.R

Suitable Machines:
Passend für Maschine:

B0266	HS327	HS327 5AX	B0385 E
B0326E	B0325E	B0266 EII	B0266 EII
B0385	B0386 V	B0386	

Spare Parts
Ersatzteile

threaded taper pin	Quantity	Tightening torque [Nm]	Order no.
Kegelgewindestift	Anzahl	Anzugsmoment [Nm]	Bestellnummer
M6X0,75	2	4	WFS.M6X0,75.TORX15PLUS

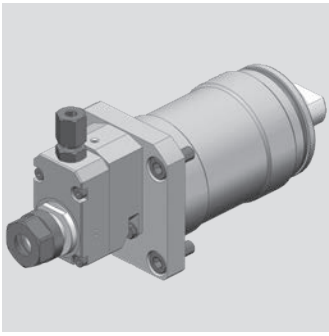

Tsugami

Axial Bohr- und Fräskopf
Axial drilling and milling head

WG 35

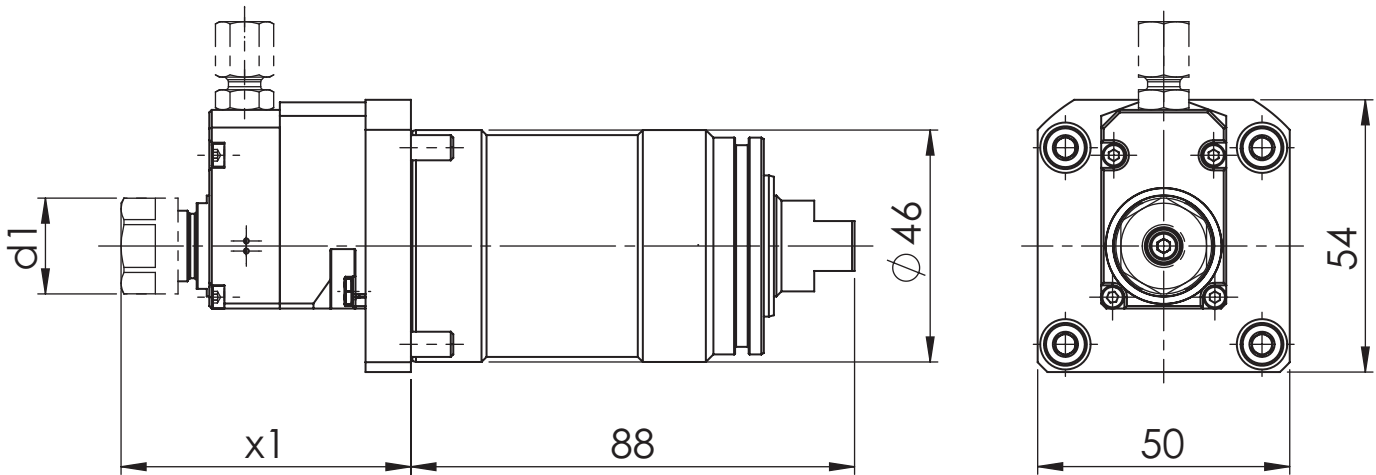

[mm]	[mm]	Spindle	[Nm]	[rpm]		Outside cooling	Internal cooling	[bar]	Order no.
d1	x1	Spindel	T max	n max	i	Aussenkühlung	Innenkühlung	p	Bestellnummer
19	51,2	ER11	2	32.000	1:4				MPU.Z46.E11.BA0.TS.I4
19	57,5	ER11	2	32.000	1:4		x	80	MPU.Z46.E11.BE0.TS.I4

Suitable Machines:

Passend für Maschine:

B0266	HS327	B0266 EII	B0266 EII
B0326E	B0325E	B0386	
B0385	B0386 V	B0385 E	

Tsugami

Axial Bohr- und Fräskopf
Axial drilling and milling head

WG 35

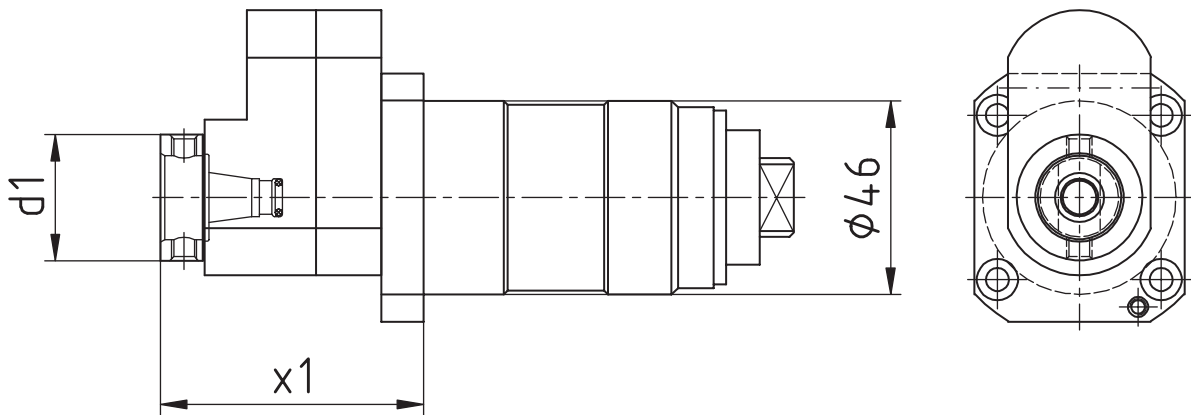
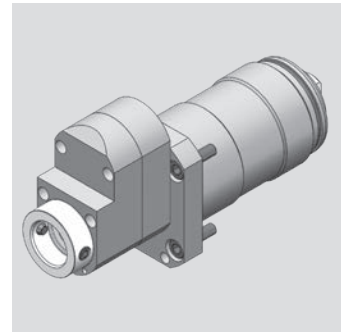

[mm]	[mm]	Spindle	[Nm]	[rpm]		Outside cooling	Internal cooling	[bar]	Order no.
d1	x1	Spindel	T max	n max	i	Aussenkühlung	Innenkühlung	p	Bestellnummer
30	62,5	WFB 20-12	3	24.000	1:3				MPU.Z46.B20.BA0.TS

Suitable Machines:

Passend für Maschine:

B0266	HS327	B0266 EII	B0266 EII
B0326E	B0325E	B0386	
B0385	B0386 V	B0385 E	

Spare Parts

Ersatzteile

threaded taper pin	Quantity	Tightening torque [Nm]	Order no.
Kegelgewindestift	Anzahl	Anzugsmoment [Nm]	Bestellnummer
M6X0,75	2	4	WFS.M6X0,75.TORX15PLUS

Modulare Aggregatetechnik

WFB Adapter



Werkzeugtechnik



**Katalog
WFB-02**



Werkzeugtechnik

Inhaltsverzeichnis für WFB-Adapter

Table of contents for WFB-adapter

Beschreibung / Description	Seite / Page
WFB - Aufsatz WFB top piece	10.2
Gebrauch und Wartung der WFB-Schnittstelle Handling and maintenance for WFB connection	10.3
Produkt-Vorteile der WFB-Schnittstelle	10.4 - 10.5
Product advantages of WFB connection	10.6 - 10.7
WFB - Produktübersicht (Auszug) WFB - Product overview	10.8 - 10.9
WFB - Grundaufnahmen / Voreinstelladapter WFB - Master shanks	10.10 - 10.11
WFB - Weldon für Zylinderschäfte DIN 1835 B WFB - Weldon for parallel shanks	10.12 - 10.15
WFB - WN für Zylinderschäfte DIN 1835 E WFB - Whistle Notch for parallel shanks	10.16 - 10.19
WFB - Schrumpffutter WFB - Shrink fit chucks	10.20 - 10.23
Bedienungsanleitung für zweigeteilte Schrumpffutter System WFB Operation instructions for two split shrink fit chucks system WFB	10.24
WFB - Sägeblattaufnahmen WFB - Tool holders for saw blade	10.25
WFB - Spannzangenfutter 8° Typ ER WFB - Collet chucks 8° type ER	10.26 - 10.27
WFB - Softsynchro® mit IKZ WFB - Softsynchro® with internal cooling system	10.28
WFB - Hydro-Dehnspannfutter WFB - Hydraulic expansion chuck	10.29
WFB-Drehhalter W-T mit IKZ WFB - Turning tool holder W-T with internal cooling system	10.30
WFB-Klemmhalter W-T HORN Mini mit IKZ WFB - Toolholder W-T HORN Mini with internal cooling system	10.31

Inhaltsverzeichnis für WFB-Adapter

Table of contents for WFB-adapter



Werkzeugtechnik

Beschreibung / Description	Seite / Page
WFB-Klemmhalter W-T HORN Supermini® mit IKZ WFB - Toolholder W-T HORN Supermini® with internal cooling system	10.32
WFB - HORN Fräserschaft mit IKZ WFB - HORN milling shank with internal cooling	10.33
WFB-Bohrstangenhalter WFB - Boring bar holder	10.34
WFB - Aufsteckfräserdorne mit IKZ WFB - Milling machine arbors with internal cooling system	10.35
WFB - Verschlussstopfen WFB - Closing plug	10.36
WFB - Reduzierungen / Verlängerungen WFB - Reductions / Extensions	10.37
WFB - Kontrolldorne WFB - Test arbors	10.38
WFB - Bohrstangen-Rohlinge WFB - Boring bar-blanks	10.39

WG = Warengruppe
Article group

WG 11 = _____

WG 35 = _____

WFB-Aufsatz
WFB top piece

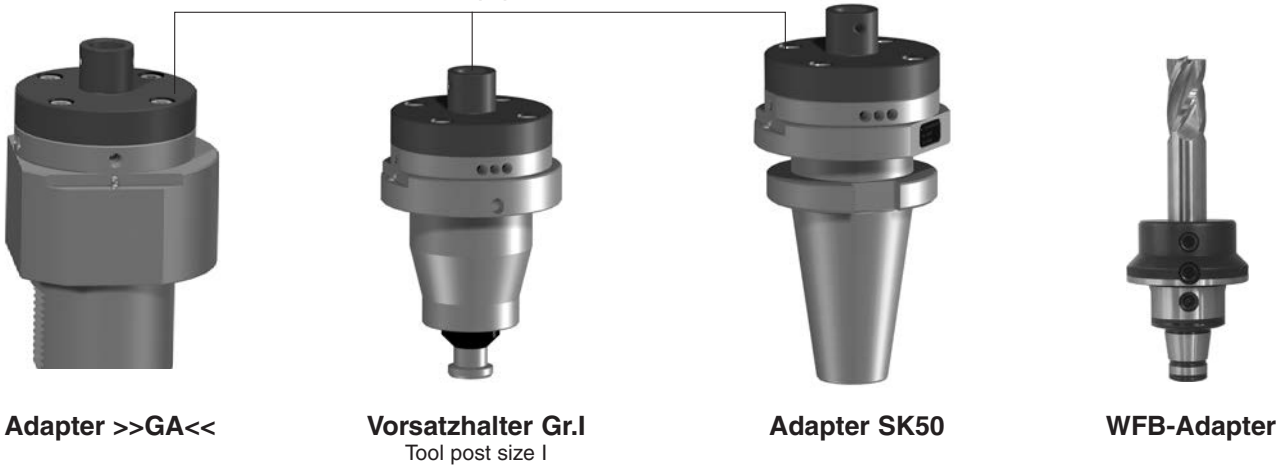

Der WFB-Adapter wird über 2 Kegelgewindestifte im WFB-Aufsatz fixiert und ist somit optimal positioniert.
The WFB-Adapter will be fixed in the WFB top piece via 2 threaded taper pins and is thus optimally positioned.

Durch die 100%-ige Einstellbarkeit der Adaptersysteme auf einem ZOLLER Einstell- und Messgerät reduziert sich die Maschinenrüstzeit nahezu gegen null. Teurer Maschinenstillstand kann somit vermieden werden.
Thanks to the excellent adjustability of the adapter systems on ZOLLER tool presetter and measuring machines setup times are reduced towards zero thus avoiding expensive machine downtimes.

- ✓ Hohe Wechselgenauigkeiten (<math><2\mu</math>) und absoluter Formschluss
High changing accuracy (<math><2\mu</math>) and absolute form fit
- ✓ Optimale Kraftübertragung und Steifigkeit durch kompakten Aufbau
Optimum power transmission and rigidity thanks to a compact assembly
- ✓ Flexible Anwendungsmöglichkeiten, wie z. B. Spannzangenfutter, Weldon, Schrumpffutter u. v. a. m.
Flexible application spectrum, e.g. collet chucks, weldon, shrink fit chucks and others
- ✓ Für angetriebene oder feststehende Werkzeuge geeignet
Suitable for driven or stationary tools
- ✓ Einsetzbar in Dreh- und Fräsmaschinen und Bearbeitungszentren
To be used in turning and milling machines and machining centres
- ✓ Einfacher und günstiger Spannmechanismus durch 2 Kegelgewindestifte
Simple and convenient clamping mechanism via 2 threaded taper pins
- ✓ Geringe Rüstzeiten
Reduced setup times
- ✓ Modular aufgebautes System, keine aufwändigen Sonderwerkzeughalter notwendig
Modular designed system, no complex tool holders required

WFB top piece	Adapter >>GA<<	Vorsatzhalter Gr.I / Tool post size I	Adapter SK50 / ISO 50
WFB-Aufsatz	Art.-Nr. / Item no.	Art.-Nr. / Item no.	Art.-Nr. / Item no.

WFB20-12	WFB.6120.Y50	WFB.6020.Y50	WFB.6320.Y50
WFB24-16	WFB.6121.Y50	WFB.6021.Y50	WFB.6321.Y50
WFB32-20	WFB.6122.Y50	WFB.6022.Y50	WFB.6322.Y50
WFB40-25	WFB.6123.Y50	WFB.6023.Y50	WFB.6323.Y50
WFB50-32	WFB.6124.Y50	WFB.6024.Y50	WFB.6324.Y50

*erhältlich bei Firma E. ZOLLER GmbH & Co. KG

Gebrauch und Wartung der WFB-Schnittstelle

Handling and maintenance for WFB connection

WG 35



Werkzeugtechnik

Hinweis zur Befestigung

Zunächst einen Kegelgewindestift anziehen, dabei 1-2 mal lösen und wieder anziehen. Dadurch wird eine optimale Positionierung der Bauteile erreicht. Der 2. Kegelgewindestift wird nun ebenfalls (wie oben angeführt) angezogen. Empfohlene Drehmomente entnehmen Sie der unteren Tabelle.

Advice for fixing

First tighten one threaded taper pin, in doing so 1 or 2 times unscrew and tighten again. Thereby you get an optimum positioning of the components. The second threaded taper pin you will tighten with the same method. Recommended locking torque see in the lower table.

Pflege und Wartung

Die Oberflächen der Planflächen, der Kegelbohrung und Kegelzapfen sind vor Gebrauch zu reinigen und mit einem Öl-Schmierfilm zu versehen. Um eine optimale Befestigung und Lösbarkeit der Kegelgewindestifte zu erreichen, wird empfohlen die Kegelgewindestifte mit z.B. Molykote 1000 oder einer ähnlichen Heiss-Schraubenpaste zu behandeln.

Support and maintenance

The surface of the face, the cone drill and cone pin must be cleaning and lubricate with oil before using. To reach an optimum fixing and resolvability of the threaded taper pins, are recommended to use for example Molykote 1000 or something similar.

Empfohlene Anzugsdrehmomente

Recommended locking torque

Größe	Kegelgewindestifte	Anzugs-Drehmoment
WFB 20-12	M6 x 0,75 / Torx 15 Plus	4 Nm
WFB 20-12	M6 x 1 / Torx T15	4 Nm
WFB 24-16	M8 x 1 / Torx T25	10 Nm
WFB 32-20	M10 x 1	20 Nm
WFB 40-25	M12 x 1	25 Nm
WFB 50-32	M14 x 1	30 Nm

Empfohlene Anzugsdrehmomente beim Einsatz von Kontrollidornen

Recommended locking torque when running test arbors

Größe	Kegelgewindestifte	Anzugs-Drehmoment
WFB 20-12	M6 x 0,75 / Torx 15 Plus	2 Nm
WFB 20-12	M6 x 1 / Torx T15	2 Nm
WFB 24-16	M8 x 1 / Torx T25	5 Nm
WFB 32-20	M10 x 1	10 Nm
WFB 40-25	M12 x 1	10 Nm
WFB 50-32	M14 x 1	15 Nm



Präzise

Die Kegel/Plananlage mit zylindrischer Abstützung gewährleistet höchste Genauigkeit (2 μ) und absoluten Form-schluß.

Flexibel

Spannzange, Weldon, Schrumpffutter, um nur die wichtigsten zu nennen, können alle in einen Grundhalter eingesetzt werden. Die Handhabung ist einfach und praxisgerecht.

Kompakt

Der extrem kompakte Aufbau gewährleistet eine optimale Kraftübertragung und Systemsteifigkeit. Daraus resultieren höhere Werkstückgenauigkeiten und verbesserte Produktivität.

Orientierte Schneidenlage

Auf Umschlag < 10 μ

Reinigung

Einfach, da überall leicht zugänglich.

Produkt-Vorteile der WFB-Schnittstelle

WG 35

W&F

Werkzeugtechnik



Plananlage

Wirtschaftlich

Sie benötigen weniger aufwändige, teure Sonderwerkzeughalter, die Werkzeugstandzeiten verlängern sich erheblich. Die Folge ist die deutliche Minimierung Ihrer Gesamtwerkzeugkosten. Mit dem WFB-System helfen wir Ihnen Ihre Drehmaschine künftig wirklich wirtschaftlich einzusetzen, und teure Nebenzeiten einzusparen. Das neue modulare WFB-System von W&F eröffnet Ihnen hinsichtlich der Präzision und der Flexibilität völlig neue Dimensionen in der Fertigungstechnik.

Spannmechanismus

Äußerst günstig durch 2 Kegelgewindestifte.

Schnell

Durch den Einsatz von Werkzeugen, die parallel zur Maschinenlaufzeit voreingestellt werden, reduziert sich die Maschinenrüstzeit nahezu auf Null. Teure Maschinenstillstandzeiten werden vermieden.

Universell

Sowohl für angetriebene als auch für feststehende Werkzeuge, sowie auf Fräsmaschinen und BAZ einsetzbar.

Schrumpfen

Nach vorne und nach innen möglich.

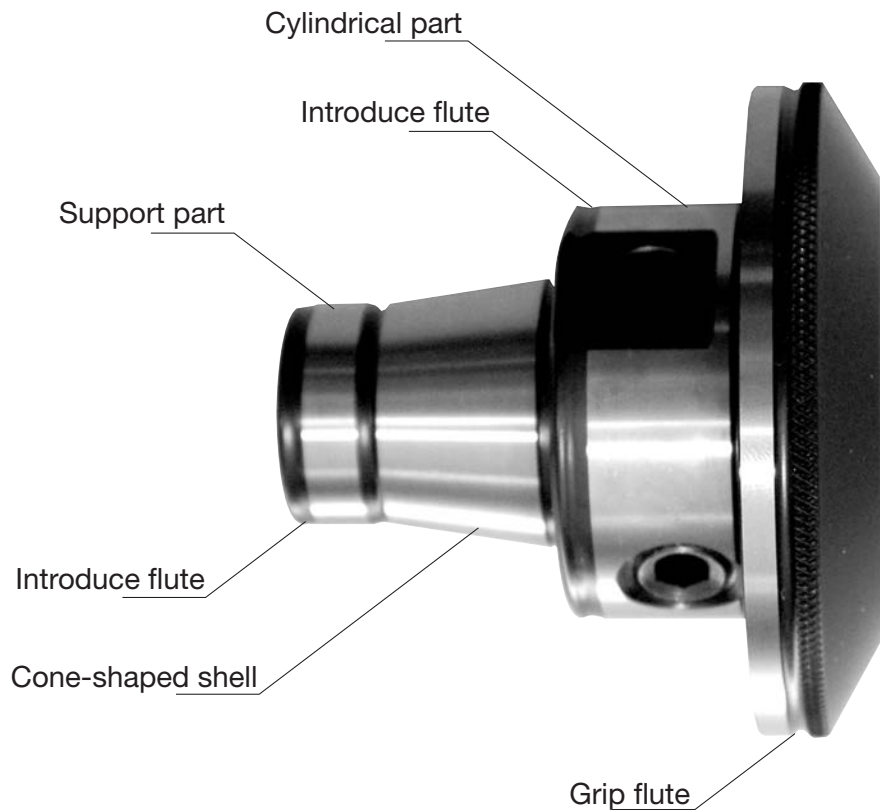

Precise

The taper/planned assets with cylindrical support guarantees highest precision (2μ) and completely form fit.

Flexibel

Collet, Weldon, schrink fit holder, etc., can be used in all master shanks. Easy and safe to handle. Collet, Weldon, schrink fit holder, etc., can be used in all master shanks. Easy and safe to handle.

Compact

The extrem compact construction guarantees an optimum load transmission and system rigidity. Out of it follow workpiece in higher precision and revised productivity.

Optimized position of cutting edge

Turnover $< 10 \mu$

Cleaning

Simple because of good accessible.

Product advantages of WFB connection

WG 35



Werkzeugtechnik



Planned assets

Economical

You need less expensive special tool holders and the tool life will be extended. So you get a minimization of complete costs of tools. With the WFB-system we help you to use your turning machine profitable in the future and to save expensive non-productive time. The new modular WFB-system from W&F enable you with precision and flexibility new dimensions in the production technology.

Gripping mechanism

Exceedingly favorable through 2 threaded taper pins.

Quick

Pre-setting of tools can be effected out of the machine. Setting-up time will be nearly zero. Expensive machine dead time will be avoided.

Universal

Applicable in driven and static tool holder, as well as on milling machine and machining center.

Shrinking

Forward and inward possible.

WFB - Aggregate

WFB - Aggregates

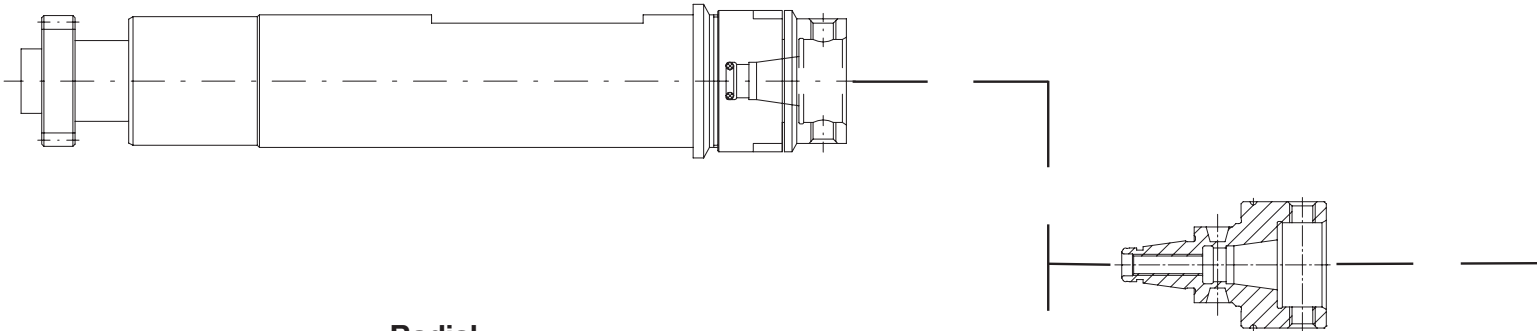
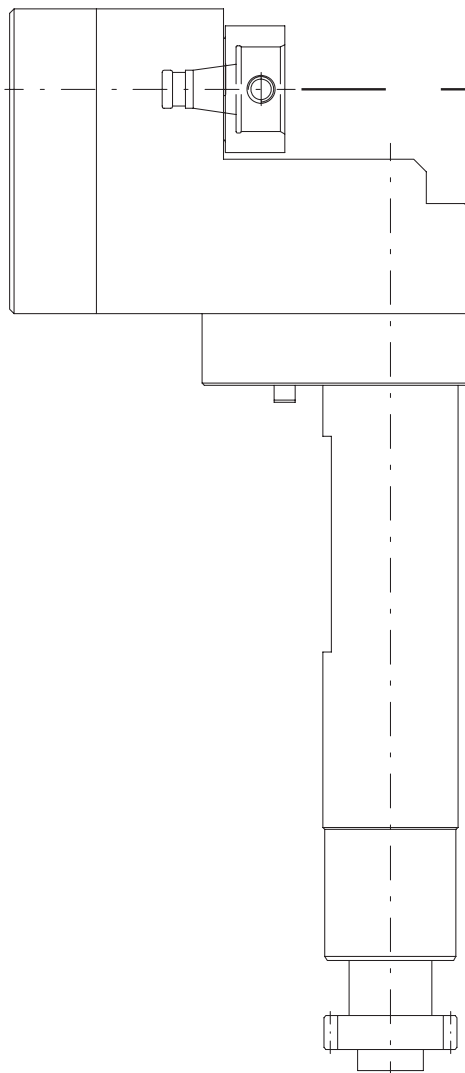
Axial**Radial****WFB - Verlängerungen**

WFB - Extensions

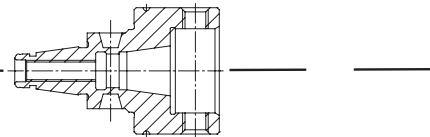

WFB - Produktübersicht (Auszug)

WFB - Product overview

WG 35



Werkzeugtechnik

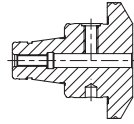

WFB - Weldon / Whistle Notch für Zylinderschäfte DIN 1835 B / E
WFB - Weldon / Whistle Notch for parallel shanks

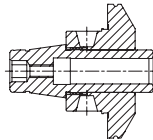

WFB - Schrumpffutter
WFB - Shrink fit chucks

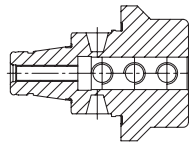

WFB - Bohrstangenhalter
WFB - Boring bar holder

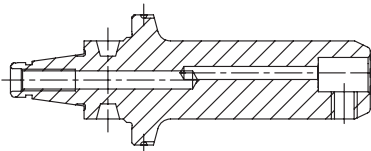

WFB - Klemmhalter W-T HORN Supermini® mit IKZ
WFB - Toolholder W-T HORN Supermini® with internal cooling system

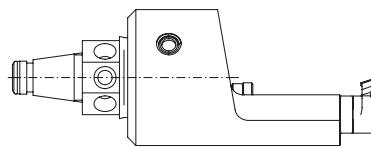

WFB - Klemmhalter W-T HORN Mini mit IKZ
WFB - Toolholder W-T HORN Mini with internal cooling system

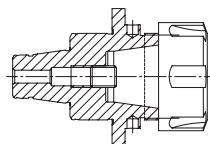

WFB - Spannzangenfutter 8° Typ ER
WFB - Collet chucks 8° type ER

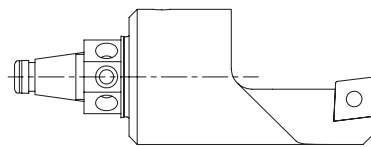

WFB - Drehhalter W-T mit IKZ
WFB - Turning tool holder W-T with internal cooling system

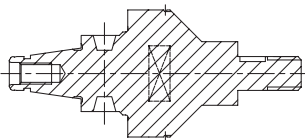

WFB - Sägeblattaufnahmen
WFB - Tool holders for saw blade

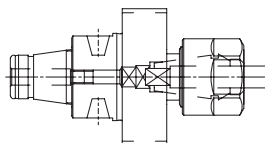

WFB - Softsynchro® mit IKZ
WFB - Softsynchro® with internal cooling system

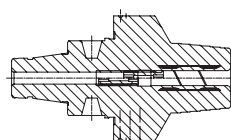

WFB - Hydro-Dehnspannfutter
WFB - Hydraulic expansion chuck

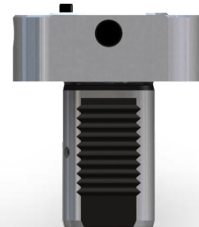
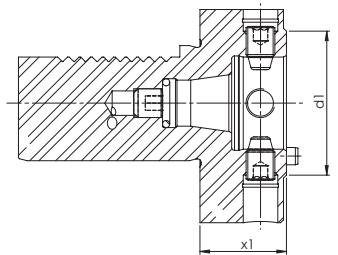
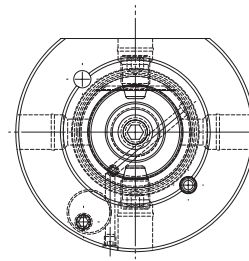
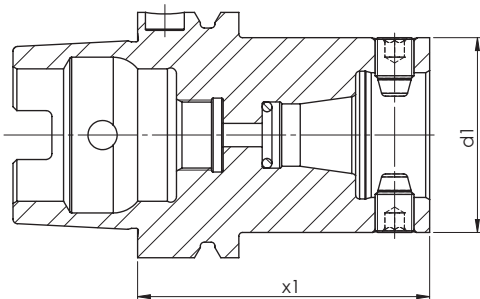

Size Größe	Type Typ	[mm] d1	[mm] x1	Order no. Bestellnummer
---------------	-------------	------------	------------	----------------------------

WFB20-12	HSK 63	30	55	WFB.020.H63
WFB24-16	HSK 63	40	65	WFB.024.H63
WFB32-20	HSK 40	50	40	WFB.032.H40
WFB32-20	HSK 63	50	75	WFB.032.H63
WFB32-20	HSK 100	50	75	WFB.032.H100
WFB 40-25	HSK 63	63	80	WFB.040.H63
WFB 40-25	HSK 100	63	90	WFB.040.H100
WFB 50-32	HSK 100	75	140	WFB.050.H100

Size Größe	Type Typ	[mm] d1	[mm] x1	Order no. Bestellnummer
---------------	-------------	------------	------------	----------------------------

WFB20-12	VDI 30	30	28	WFB.020.V30
WFB24-16	VDI 30	40	28	WFB.024.V30
WFB32-20	VDI 25	50	28	WFB.032.V25
WFB32-20	VDI 30	50	28	WFB.032.V30
WFB32-20	VDI 40	50	30	WFB.032.V40
WFB 40-25	VDI 40	63	30	WFB.040.V40
WFB 40-25	VDI 50	63	30	WFB.040.V50
WFB 50-32	VDI 50	75	35	WFB.050.V50

WFB - Grundaufnahmen / Voreinstelladapter

WFB - Master shanks

WG 35



Werkzeugtechnik

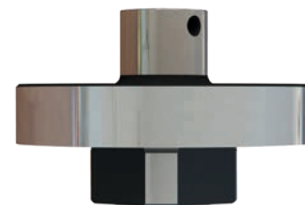
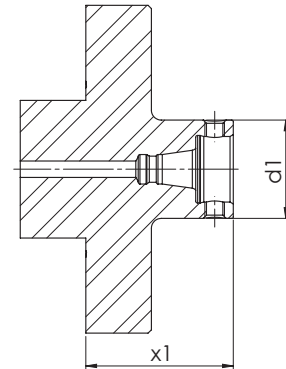
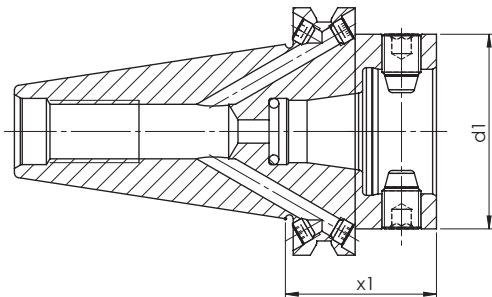

Size Größe	Type Typ	[mm] d1	[mm] x1	Order no. Bestellnummer
WFB20-12	SK 40	30	40	WFB.020.S40
WFB20-12	SK 50	30	40	WFB.020.S50
WFB24-16	SK 40	40	40	WFB.024.S40
WFB24-16	SK 50	40	40	WFB.024.S50
WFB32-20	SK 30	50	40	WFB.032.S30
WFB32-20	SK 40	50	40	WFB.032.S40
WFB32-20	SK 50	50	40	WFB.032.S50
WFB 40-25	SK 40	63	50	WFB.040.S40
WFB 40-25	SK 50	63	50	WFB.040.S50
WFB 50-32	SK 50	75	50	WFB.050.S50

Size Größe	Type Typ	[mm] d1	[mm] x1	Order no. Bestellnummer
WFB20-12	Z01	30	45	WFB.020.SHT.Z01
WFB24-16	Z01	40	45	WFB.024.SHT.Z01
WFB32-20	Z01	50	45	WFB.032.SHT.Z01
WFB 40-25	Z01	63	45	WFB.040.SHT.Z01
WFB 50-32	Z01	75	45	WFB.050.SHT.Z01

WFB - Weldon für Zylinderschäfte DIN 1835 B

WFB - Weldon for parallel shanks

WG 35

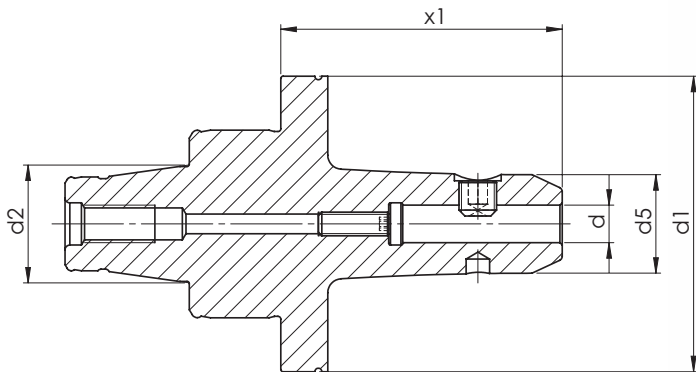
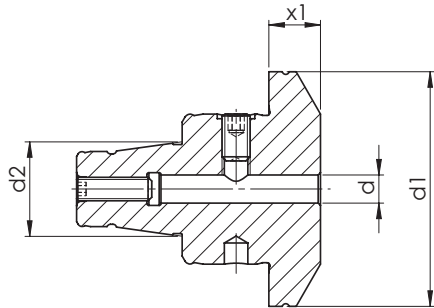

Verwendung: Zum Spannen von Werkzeugen mit Zylinderschaft DIN 1835 Form B.

Lieferumfang: Mit eingebauter Spanschraube

Application: For clamping tools with parallel shank DIN 1835 form B.

Scope of supply: Weldon end mill adaptor incl. locking screw

WFB - Weldon für Zylinderschäfte DIN 1835 B

WFB - Weldon for parallel shanks

WG 35



Werkzeugtechnik

Size Größe	[mm] d	[mm] d1	[mm] d2	[mm] d5	[mm] x1	Order no. Bestellnummer
WFB 20-12	3	29	12	12	25	WFB.203.025K
WFB 20-12	4	29	12	14	25	WFB.204.025K
WFB 20-12	6	29	12	17	16	WFB.206.016K
WFB 20-12	6	29	12	17	27	WFB.206.027K
WFB 20-12	6	30	12	17	27	WFB.206.027T
WFB 20-12	6	30	12	17	43	WFB.206.043.S
WFB 20-12	6	30	12	25	42,5	WFB.206.043T
WFB 20-12	8	29	12	21	16	WFB.208.016K
WFB 20-12	8	29	12	21	27	WFB.208.027K
WFB 20-12	8	30	12	21	27	WFB.208.027T
WFB 20-12	8	30	12	25	42,5	WFB.208.043T
WFB 20-12	10	29	12	24	37	WFB.210.037K
WFB 20-12	10	30	12	24	37	WFB.210.037T
WFB 20-12	10	30	12	25	42,5	WFB.210.043T
WFB 20-12	16	30	12	33	55	WFB.216.055
WFB 24-16	6	40	16	11	14	WFB.246.014T
WFB 24-16	6	40	16	17	27	WFB.246.027T
WFB 24-16	8	40	16	21	27	WFB.248.027T
WFB 24-16	10	40	16	17	15	WFB.241.015T
WFB 24-16	10	40	16	24	25	WFB.241.025T
WFB 24-16	12	40	16	27	30	WFB.241.230T
WFB 32-20	4	50	20	14	28	WFB.304.028
WFB 32-20	6	50	20	-	11	WFB.306.011
WFB 32-20	6	50	20	17	28	WFB.306.028T
WFB 32-20	6	50	20	17	40	WFB.306.040
WFB 32-20	6	50	20	17	60	WFB.306.060
WFB 32-20	8	50	20	-	11	WFB.308.011
WFB 32-20	8	50	20	21	28	WFB.308.028T
WFB 32-20	8	50	20	21	40	WFB.308.040
WFB 32-20	8	50	20	21	60	WFB.308.060
WFB 32-20	10	50	20	-	11	WFB.310.011
WFB 32-20	10	50	20	24	25	WFB.310.025T
WFB 32-20	10	50	20	24	35	WFB.310.035
WFB 32-20	10	50	20	24	60	WFB.310.060
WFB 32-20	12	50	20	27	14	WFB.312.014T
WFB 32-20	12	50	20	-	15	WFB.312.015
WFB 32-20	12	50	20	27	35	WFB.312.035



Werkzeugtechnik

WFB - Weldon für Zylinderschäfte DIN 1835 B

WFB - Weldon for parallel shanks

WG 35

Size Größe	[mm] d	[mm] d1	[mm] d2	[mm] d5	[mm] x1	Order no. Bestellnummer
WFB 32-20	12	50	20	27	60	WFB.312.060
WFB 32-20	14	50	20	50	31	WFB.314.031
WFB 32-20	14	50	20	29	60	WFB.314.060
WFB 32-20	16	50	20	50	44	WFB.316.044
WFB 32-20	16	50	20	35	60	WFB.316.060
WFB 32-20	18	50	20	50	44	WFB.318.044
WFB 32-20	18	50	20	35	60	WFB.318.060
WFB 32-20	20	50	20	50	47	WFB.320.047
WFB 32-20	20	50	20	39	60	WFB.320.060
WFB 32-20	25	50	20	47	60	WFB.325.060
WFB 40-25	4	63	25	14	45	WFB.404.045
WFB 40-25	6	63	25	-	13	WFB.406.013
WFB 40-25	6	63	25	17	60	WFB.406.060
WFB 40-25	8	63	25	-	13	WFB.408.013
WFB 40-25	8	63	25	21	60	WFB.408.060
WFB 40-25	10	63	25	-	12	WFB.410.012
WFB 40-25	10	63	25	24	60	WFB.410.060
WFB 40-25	12	63	25	-	14,5	WFB.412.014
WFB 40-25	12	63	25	27	60	WFB.412.060
WFB 40-25	14	63	25	-	14,5	WFB.414.014
WFB 40-25	14	63	25	29	60	WFB.414.060
WFB 40-25	16	63	25	-	34	WFB.416.034
WFB 40-25	16	63	25	33	60	WFB.416.060
WFB 40-25	18	63	25	-	34	WFB.418.034
WFB 40-25	18	63	25	35	60	WFB.418.060
WFB 40-25	20	63	25	-	36	WFB.420.036
WFB 40-25	20	63	25	39	60	WFB.420.060
WFB 40-25	25	63	25	47	60	WFB.425.060
WFB 50-32	3	75	32	12	35	WFB.503.035
WFB 50-32	6	75	32	-	13	WFB.506.013
WFB 50-32	6	75	32	17	35	WFB.506.035
WFB 50-32	6	75	32	17	60	WFB.506.060
WFB 50-32	8	75	32	-	13	WFB.508.013
WFB 50-32	8	75	32	21	35	WFB.508.035
WFB 50-32	8	75	32	21	60	WFB.508.060
WFB 50-32	10	75	32	-	13	WFB.510.013
WFB 50-32	10	75	32	24	35	WFB.510.035

WFB - Weldon für Zylinderschäfte DIN 1835 B

WFB - Weldon for parallel shanks

WG 35



Werkzeugtechnik

Size Größe	[mm] d	[mm] d1	[mm] d2	[mm] d5	[mm] x1	Order no. Bestellnummer
WFB 50-32	10	75	32	24	60	WFB.510.060
WFB 50-32	12	75	32	-	15	WFB.512.015
WFB 50-32	12	75	32	27	35	WFB.512.035
WFB 50-32	12	75	32	27	60	WFB.512.060
WFB 50-32	14	75	32	-	15	WFB.514.015
WFB 50-32	14	75	32	29	35	WFB.514.035
WFB 50-32	14	75	32	29	60	WFB.514.060
WFB 50-32	16	75	32	-	15	WFB.516.015
WFB 50-32	16	75	32	33	35	WFB.516.035
WFB 50-32	16	75	32	33	60	WFB.516.060
WFB 50-32	18	75	32	-	15	WFB.518.015
WFB 50-32	18	75	32	35	35	WFB.518.035
WFB 50-32	18	75	32	35	60	WFB.518.060
WFB 50-32	20	75	32	-	15	WFB.520.015
WFB 50-32	20	75	32	39	35	WFB.520.035
WFB 50-32	20	75	32	39	60	WFB.520.060
WFB 50-32	25	75	32	47	39	WFB.525.039
WFB 50-32	25	75	32	47	80	WFB.525.080
WFB 50-32	32	75	32	57	65	WFB.532.065



Werkzeugtechnik

WFB - WN für Zylinderschäfte DIN 1835 E

WFB - Whistle Notch for parallel shanks

WG 35

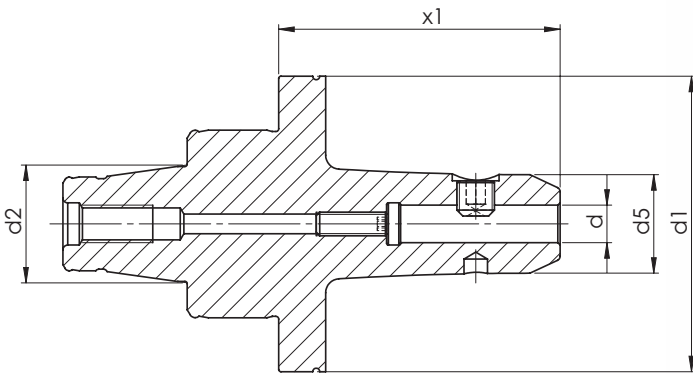
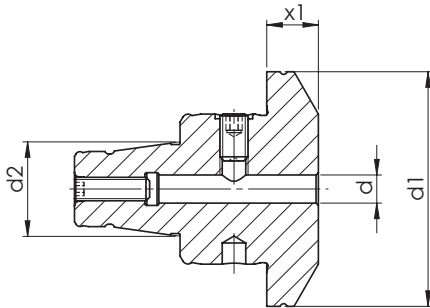

Verwendung: Zum Spannen von Werkzeugen mit Zylinderschaft DIN 1835 Form E

Lieferumfang: Mit eingebauter Spann- und Anschlagschraube

Application: For clamping tools with parallel shank DIN 1835 form E

Scope of supply: Weldon end mill adaptor incl. locking screw and adjusting screw

WFB - WN für Zylinderschäfte DIN 1835 E

WFB - Whistle Notch for parallel shanks

WG 35



Werkzeugtechnik

Size Größe	[mm] d	[mm] d1	[mm] d2	[mm] d5	[mm] x1	Order no. Bestellnummer
WFB20-12	6	30	12	17	27	WFB.206.127T
WFB20-12	6	29	12	17	27	WFB.206.127K
WFB20-12	6	30	12	25	42,5	WFB.206.143T
WFB20-12	8	29	12	21	27	WFB.208.127K
WFB20-12	8	30	12	21	27	WFB.208.127T
WFB20-12	8	30	12	25	42,5	WFB.208.143T
WFB20-12	8	29	12	25	42,5	WFB.208.143K
WFB20-12	10	29	12	24	37	WFB.210.137K
WFB20-12	10	30	12	24	37	WFB.210.137T
WFB20-12	10	30	12	25	42,5	WFB.210.143T
WFB24-16	6	40	16	11	14	WFB.246.114T
WFB24-16	6	40	16	17	27	WFB.246.127T
WFB24-16	8	40	16	21	27	WFB.248.127T
WFB24-16	10	40	16	17	15	WFB.241.115T
WFB24-16	10	40	16	24	25	WFB.241.125T
WFB24-16	12	40	16	27	30	WFB.241.330T
WFB32-20	4	50	20	14	28	WFB.304.128
WFB32-20	6	50	20	-	11	WFB.306.111
WFB32-20	6	50	20	17	28	WFB.306.128T
WFB32-20	6	50	20	17	40	WFB.306.140
WFB32-20	6	50	20	17	60	WFB.306.160
WFB32-20	8	50	20	-	11	WFB.308.111
WFB32-20	8	50	20	21	40	WFB.308.140
WFB32-20	8	50	20	21	60	WFB.308.160
WFB32-20	8	50	20	21	28	WFB.308.128T
WFB32-20	10	50	20	-	11	WFB.310.111
WFB32-20	10	50	20	24	25	WFB.310.125T
WFB32-20	10	50	20	24	35	WFB.310.135
WFB32-20	10	50	20	24	60	WFB.310.160
WFB32-20	12	50	20	27	14	WFB.312.114T
WFB32-20	12	50	20	-	15	WFB.312.115
WFB32-20	12	50	20	27	35	WFB.312.135
WFB32-20	12	50	20	27	60	WFB.312.160
WFB32-20	14	50	20	50	31	WFB.314.131
WFB32-20	14	50	20	29	60	WFB.314.160
WFB32-20	16	50	20	50	44	WFB.316.144
WFB32-20	16	50	20	35	60	WFB.316.160.WN



Werkzeugtechnik

WFB - WN für Zylinderschäfte DIN 1835 E

WFB - Whistle Notch for parallel shanks

WG 35

Size Größe	[mm] d	[mm] d1	[mm] d2	[mm] d5	[mm] x1	Order no. Bestellnummer
WFB32-20	18	50	20	50	44	WFB.318.144
WFB32-20	18	50	20	35	60	WFB.318.160
WFB32-20	20	50	20	50	47	WFB.320.147
WFB32-20	20	50	20	39	60	WFB.320.160
WFB32-20	25	50	20	47	60	WFB.325.160
WFB 40-25	6	63	25	-	13	WFB.406.113
WFB 40-25	6	63	25	17	60	WFB.406.160
WFB 40-25	8	63	25	-	13	WFB.408.113
WFB 40-25	8	63	25	21	60	WFB.408.160
WFB 40-25	10	63	25	-	12	WFB.410.112
WFB 40-25	10	63	25	24	60	WFB.410.160
WFB 40-25	12	63	25	-	14,5	WFB.412.114
WFB 40-25	12	63	25	27	60	WFB.412.160
WFB 40-25	14	63	25	-	14,5	WFB.414.114
WFB 40-25	14	63	25	29	60	WFB.414.160
WFB 40-25	16	63	25	-	34	WFB.416.134
WFB 40-25	16	63	25	33	60	WFB.416.160
WFB 40-25	18	63	25	-	34	WFB.418.134
WFB 40-25	18	63	25	35	60	WFB.418.160
WFB 40-25	20	63	25	-	36	WFB.420.136
WFB 40-25	20	63	25	39	60	WFB.420.160
WFB 40-25	25	63	25	47	60	WFB.425.160
WFB 50-32	6	75	32	-	13	WFB.506.113
WFB 50-33	6	75	32	17	35	WFB.506.135
WFB 50-32	6	75	32	17	60	WFB.506.160
WFB 50-32	8	75	32	-	13	WFB.508.113
WFB 50-33	8	75	32	21	35	WFB.508.135
WFB 50-32	8	75	32	21	60	WFB.508.160
WFB 50-32	10	75	32	-	13	WFB.510.113
WFB 50-33	10	75	32	24	35	WFB.510.135
WFB 50-32	10	75	32	24	60	WFB.510.160
WFB 50-32	12	75	32	-	15	WFB.512.115
WFB 50-33	12	75	32	27	35	WFB.512.035
WFB 50-32	12	75	32	27	60	WFB.512.160
WFB 50-32	14	75	32	-	15	WFB.514.115
WFB 50-32	14	75	32	29	35	WFB.514.135
WFB 50-32	14	75	32	29	60	WFB.514.160

WFB - WN für Zylinderschäfte DIN 1835 E

WFB - Whistle Notch for parallel shanks

WG 35



Werkzeugtechnik

Size Größe	[mm] d	[mm] d1	[mm] d2	[mm] d5	[mm] x1	Order no. Bestellnummer
WFB 50-32	16	75	32	-	15	WFB.516.115
WFB 50-32	16	75	32	33	35	WFB.516.135
WFB 50-32	16	75	32	33	60	WFB.516.160
WFB 50-32	18	75	32	-	15	WFB.518.115
WFB 50-32	18	75	32	35	35	WFB.518.135
WFB 50-32	18	75	32	35	60	WFB.518.160
WFB 50-32	20	75	32	-	15	WFB.520.115
WFB 50-32	20	75	32	39	35	WFB.520.135
WFB 50-32	20	75	32	39	60	WFB.520.160
WFB 50-32	25	75	32	47	39	WFB.525.139
WFB 50-32	25	75	32	47	80	WFB.525.180
WFB 50-32	32	75	32	57	65	WFB.532.165

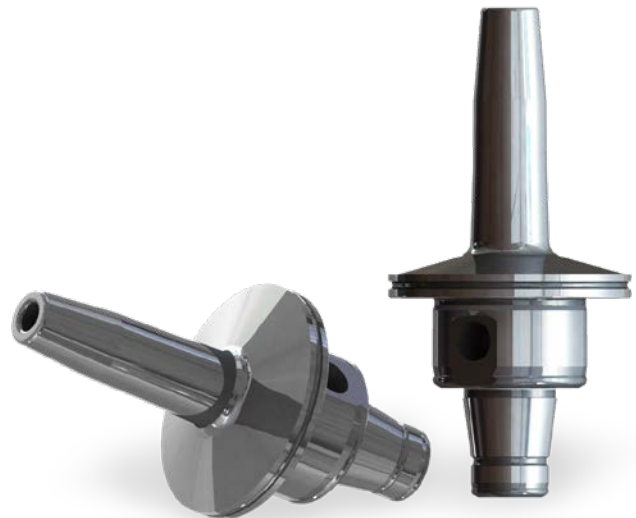
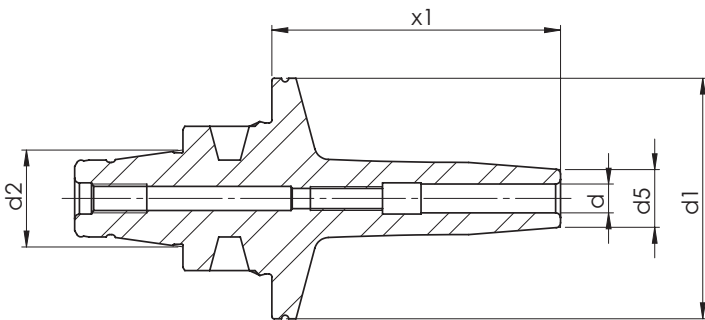
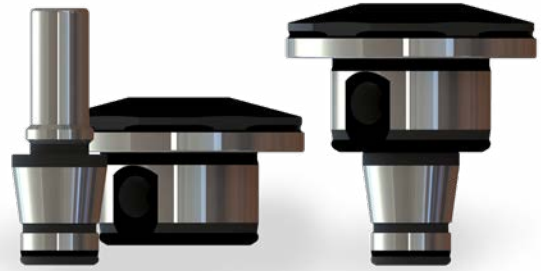
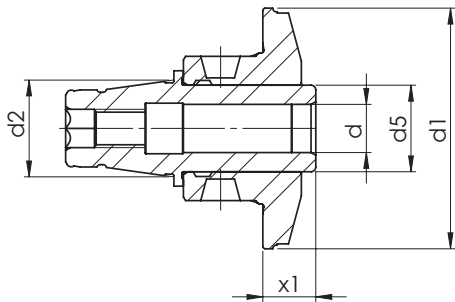

WFB - Schrumpffutter

WFB - Shrink fit chucks

WG 35



Werkzeugtechnik

Size Größe	[mm] d	[mm] d1	[mm] d2	[mm] d5	[mm] x1	Order no. Bestellnummer
WFB20-12	3	30	12	10	37	WFB.203.037.SFR
WFB20-12	3	30	12	10	51	WFB.203.051.SFR
WFB20-12	3	30	12	9	17	WFB.S20.003.017.SF*
WFB20-12	3	29	12	9	17	WFB.S20.003.017.SFK*
WFB20-12	4	30	12	13	35	WFB.204.035.SFR
WFB20-12	4	30	12	12	50	WFB.204.050.SFR
WFB20-12	4	30	12	9	17	WFB.S20.004.017.SF*
WFB20-12	4	29	12	9	17	WFB.S20.004.017.SFK*
WFB20-12	6	30	12	13	32	WFB.206.032.SFR
WFB20-12	6	30	12	15	47	WFB.206.047.SFR
WFB20-12	6	30	12	14	17	WFB.S20.006.017.SF*
WFB20-12	6	30	12	14	27	WFB.S20.006.027.SF*
WFB20-12	6	29	12	14	27	WFB.S20.006.027.SFK*
WFB20-12	8	30	12	15	30	WFB.208.030.SFR
WFB20-12	8	30	12	17	45	WFB.208.045.SFR
WFB20-12	8	30	12	14	20	WFB.S20.008.020.SF*
WFB20-12	8	30	12	14	27	WFB.S20.008.027.SF*
WFB20-12	8	29	12	14	27	WFB.S20.008.027.SFK*
WFB20-12	10	30	12	16	27	WFB.S20.010.027.SF*
WFB20-12	12	30	12	18	35	WFB.2H0.D12.SFR
WFB24-16	3	40	16	13	34	WFB.243.034.SFR
WFB24-16	4	40	16	13	34	WFB.244.034.SFR
WFB24-16	6	40	16	13	30	WFB.246.030.SFR
WFB24-16	8	40	16	14	30	WFB.248.030.SFR
WFB24-16	10	40	16	17	30	WFB.241.030.SFR
WFB32-20	3	50	20	13	37	WFB.303.037.SFR
WFB32-20	3	50	20	10	60	WFB.303.060.SFR
WFB32-20	3	50	20	20	11	WFB.S32.003.011.SF*
WFB32-20	3	50	20	13	37	WFB.S32.003.037.SF*
WFB32-20	4	50	20	13	35	WFB.304.035.SFR
WFB32-20	4	50	20	12	60	WFB.304.060.SFR
WFB32-20	4	50	20	20	11	WFB.S32.004.011.SF*
WFB32-20	5	50	20	13	60	WFB.305.060.SFR
WFB32-20	5	50	20	20	11	WFB.S32.005.011.SF*
WFB32-20	6	50	20	13	32	WFB.306.032.SFR
WFB32-20	6	50	20	15	60	WFB.306.060.SFR
WFB32-20	6	50	20	20	11	WFB.S32.006.011.SF*

* = Zweigeteilte Ausführung / Two split construction



Werkzeugtechnik

WFB - Schrumpffutter

WFB - Shrink fit chucks

WG 35

Size Größe	[mm] d	[mm] d1	[mm] d2	[mm] d5	[mm] x1	Order no. Bestellnummer
WFB32-20	6	50	20	13	32	WFB.S32.006.032.SF*
WFB32-20	8	50	20	15	30	WFB.308.030.SFR
WFB32-20	8	50	20	17	60	WFB.308.060.SFR
WFB32-20	8	50	20	20	11	WFB.S32.008.011.SF*
WFB32-20	8	50	20	15	30	WFB.S32.008.030.SF*
WFB32-20	10	50	20	22	60	WFB.310.060.SFR
WFB32-20	10	50	20	18	11	WFB.S32.010.011.SF*
WFB32-20	10	50	20	18	25	WFB.S32.010.025.SF*
WFB32-20	12	50	20	26	60	WFB.312.030.SFR
WFB32-20	12	50	20	25	60	WFB.312.060.SFR
WFB32-20	12	50	20	18	11	WFB.S32.012.011.SF*
WFB32-20	12	50	20	18	11	WFB.S32.012.011.SF.*
WFB32-20	12	50	20	18	30	WFB.S32.012.030.SF*
WFB32-20	14	50	20	30	60	WFB.314.060.SFR
WFB32-20	14	50	20	27	25	WFB.S32.014.025.SF*
WFB32-20	16	50	20	30	60	WFB.316.060.SFR
WFB32-20	16	50	20	27	25	WFB.S32.016.025.SF*
WFB32-20	16	50	20	27	32	WFB.S32.016.032.SF*
WFB 40-25	3	63	25	10	60	WFB.403.060.SFR
WFB 40-25	4	63	25	12	60	WFB.404.060.SFR
WFB 40-25	6	63	25	15	60	WFB.406.060.SFR
WFB 40-25	8	63	25	17	60	WFB.408.060.SFR
WFB 40-25	10	63	25	22	60	WFB.410.060.SFR
WFB 40-25	12	63	25	25	60	WFB.412.060.SFR
WFB 40-25	14	63	25	27	60	WFB.414.060.SFR
WFB 40-25	16	63	25	30	60	WFB.416.060.SFR
WFB 40-25	18	63	25	32	60	WFB.418.060.SFR
WFB 40-25	20	63	25	32	60	WFB.420.060.SFR
WFB 50-32	3	75	32	10	35	WFB.503.035.SFR
WFB 50-32	6	75	32	15	40	WFB.506.040.SFR
WFB 50-32	6	75	32	15	60	WFB.506.060.SFR
WFB 50-32	8	75	32	17	40	WFB.508.040.SFR
WFB 50-32	8	75	32	17	60	WFB.508.060.SFR
WFB 50-32	10	75	32	22	40	WFB.510.040.SFR
WFB 50-32	10	75	32	22	60	WFB.510.060.SFR
WFB 50-32	12	75	32	25	40	WFB.512.040.SFR
WFB 50-32	12	75	32	25	60	WFB.512.060.SFR

* = Zweigeteilte Ausführung / Two split construction

WFB - Schrumpffutter

WFB - Shrink fit chucks

WG 35



Werkzeugtechnik

Size Größe	[mm] d	[mm] d1	[mm] d2	[mm] d5	[mm] x1	Order no. Bestellnummer
WFB 50-32	14	75	32	30	60	WFB.514.060.SFR
WFB 50-32	16	75	32	30	60	WFB.516.060.SFR
WFB 50-32	18	75	32	32	60	WFB.518.060.SFR
WFB 50-32	20	75	32	32	60	WFB.520.060.SFR
WFB 50-32	25	75	32	42	60	WFB.525.060.SFR
WFB 40-25	6	63	25	40	15	WFB.S40.006.015.SF*
WFB 40-25	8	63	25	40	15	WFB.S40.008.015.SF*
WFB 40-25	10	63	25	20	16	WFB.S40.010.016.SF*
WFB 40-25	12	63	25	20	21	WFB.S40.012.021.SF*
WFB 40-25	14	63	25	21	21	WFB.S40.014.021.SF*
WFB 40-25	16	63	25	40	15	WFB.S40.016.015.SF*
WFB 40-25	16	63	25	29	33	WFB.S40.016.033.SF*
WFB 40-25	18	63	25	40	15	WFB.S40.018.015.SF*
WFB 40-25	18	63	25	29	33	WFB.S40.018.033.SF*
WFB 40-25	20	63	25	31	33	WFB.S40.020.033.SF*

* = Zweigeteilte Ausführung / Two split construction

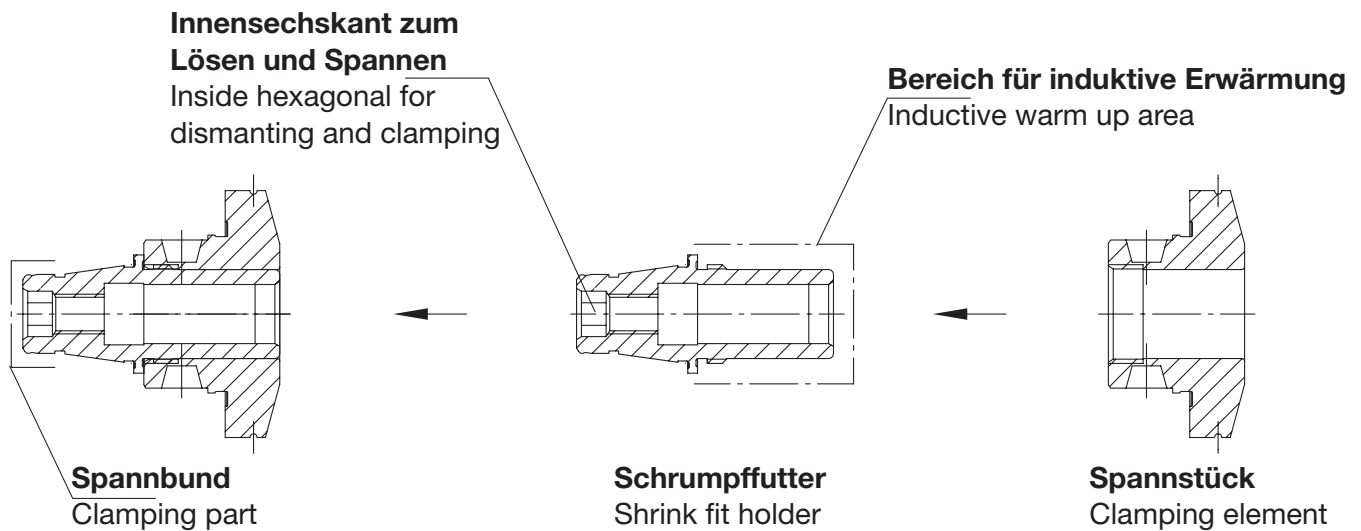

Funktionsweise:

Mode of operation:

1. WFB Schrumpfadapter demontieren. Zum Lösen und Spannen darf nur der im Schrumpffutter eingebrachte Sechskant genutzt werden.

WFB shrink fit chucks disassemble. Please use the inside hexagonal for dismantling and clamping.

2. Schrumpfadapter am Spannbund in Grundaufnahme (Spannzangenfutter) aufnehmen.

Put the shrink adapter with clamping sight in the collet chuck from the machine.

3. Induktiv erwärmen und Schneidwerkzeug einschrumpfen.

Inductive heat up and shrinking cutting tools.

4. Schrumpffutter abkühlen lassen.

Let cool down the shrink adapter.

5. Spannstück und Schrumpffutter zusammen montieren.

Clamping element and shrink fit holder must be mounting together.

Wichtiger Hinweis:

Important information:

WFB Schrumpffutter in kurzer Ausführung bestehen aus dem eigentlichen Schrumpffutter und dem Spannstück. Beide Teile werden in zusammengebauten Zustand ausgeliefert und sind mit der gleichen Kennung beschriftet. Achtung! Nur Teile mit gleicher Kennung dürfen als Adapter montiert werden.

WFB shrink fit holder in short construction consists of shrink fit holder and clamping element. Both element will be delivered in assembled condition and they are marked with the same identification. Attention! Only parts with the same identification may be assembled as adapter.

WFB - Sägeblattaufnahmen

WFB - Tool holders for saw blade

WG 35



Werkzeugtechnik

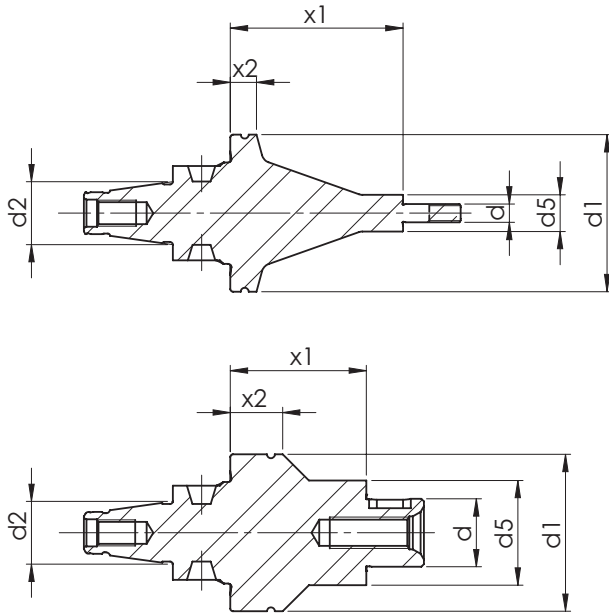

Lieferumfang:

Bei Ø 3,5 mm inkl. 1 St. M3,5x0,6-Mutter,
je 1 St. Fräsdornring 3,5x6,5x1 - 3,5x6,5x2 mm.

Bei Ø 5 mm inkl. 1 St. M5-Mutter,
1 St. Fräsdornring 5x9x1 mm, 2 St. Fräsdornringe 5x9x2 mm.

Bei Ø 8 mm inkl. 1 St. M8x1-Mutter, 1 St. Passfeder 2x2x6 mm,
je 1 St. Fräsdornring 8x14x1 - 8x14x3 - 8x14x4 mm.

Bei Ø 10 mm inkl. 1 St. M10x1-Mutter, 1 St. Passfeder 3x3x7 mm,
je 1 St. Fräsdornring 10x16x0,5 - 10x16x1 - 10x16x3 - 10x16x5 mm.

Bei Ø 13 mm inkl. 1 St. Fräseranzugsschraube, 1 St. Passfeder 4x4x8 mm,
je 1 St. Fräsdornring 13x21x0,5 - 13x22x1 - 13x22x3 - 13x22x5 mm.

Bei Ø 16 mm inkl. 1 St. Fräseranzugsschraube, 1 St. Passfeder 4x4x10 mm,
je 1 St. Fräsdornring 16x25x1 - 16x27x2 - 16x27x3 - 16x27x10 mm.

Bei Ø 22 mm inkl. 1 St. Fräseranzugsschraube, 1 St. Passfeder 6x6x14 mm,
je 1 St. Fräsdornring 22x33x1 - 22x34x2 - 22x34x6 - 22x34x10 mm.

Size Größe	[mm] d	[mm] d1	[mm] d2	[mm] d5	[mm] x1	[mm] x2	Order no. Bestellnummer
WFB20-12	3,5	30	12	7	33	5	WFB.035A.2033
WFB20-12	5	30	12	10	33	5	WFB.05A.2033
WFB20-12	8	30	12	15	26	10	WFB.08A.2026
WFB20-12	10	30	12	17	26	10	WFB.10A.2026
WFB20-12	13	30	12	20	26	10	WFB.13A.2026
WFB20-12	16	30	12	24	26	10	WFB.16A.2026
WFB20-12	22	30	20	34	26	10	WFB.22A.2026

WFB - Spannzangenfutter 8° Typ ER

WFB - Collet chucks 8° type ER

WG 35

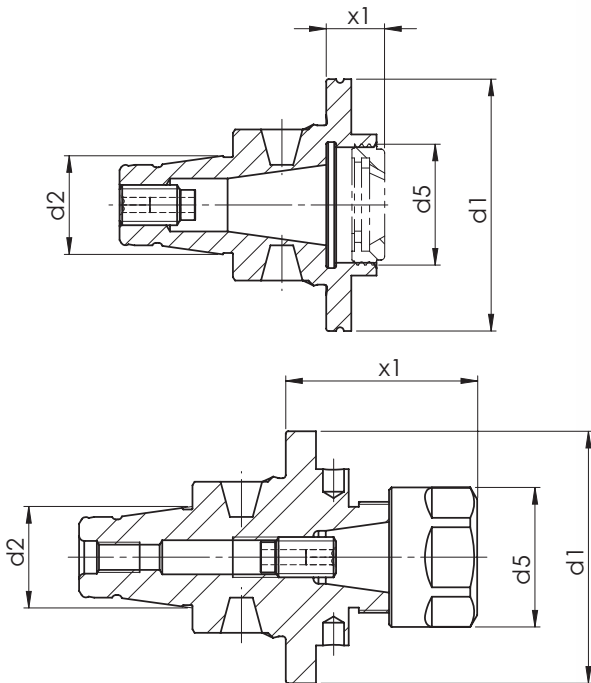

Verwendung: Zur Aufnahme von Werkzeugen mit Zylinderschaft in Spannzangen DIN 6499.

Lieferumfang: Fräterspannfutter mit Spannmutter und Anschlagschraube.

Spannzangen: Siehe Seite 11.1

Application: To hold tools with parallel shank in collets DIN 6499

Scope of supply: Collet chucks with collet nut and adjusting screw.

Size Größe	[mm] d	[mm] d1	[mm] d2	[mm] d5	[mm] x1	Order no. Bestellnummer
WFB20-12	ER8 M	30	12	12	25	WFB.208.025MINI
WFB20-12	ER8 M	30	12	12	57	WFB.208.057MINI
WFB20-12	ER11	30	12	16	25	WFB.211.025MINI
WFB20-12	ER11 A	29	12	18	10	WFB.211.A10K
WFB20-12	ER11 A	30	12	18	10	WFB.211.A10T
WFB20-12	ER11	29	12	19	25	WFB.211.025K
WFB20-12	ER11	30	12	19	25	WFB.211.025T
WFB20-12	ER11	30	12	19	45	WFB.211.045T
WFB20-12	ER16 M	30	12	22	28	WFB.216.028MINI
WFB20-12	ER16	29	12	28	28	WFB.216.028K
WFB20-12	ER16	30	12	28	28	WFB.216.028T
WFB20-12	ER16	30	12	28	43	WFB.216.043T
WFB20-12	ER20 M	30	12	28	36	WFB.220.036MINI
WFB20-12	ER20 M	30	12	28	41	WFB.220.041MINI

A* = Innenliegende Spannmutter / Internal collet nut

M* = Mini Spannmutter / Mini-collet nut

WFB - Spannzangenfutter 8° Typ ER

WFB - Collet chucks 8° type ER

WG 35



Werkzeugtechnik

Size Größe	[mm] d	[mm] d1	[mm] d2	[mm] d5	[mm] x1	Order no. Bestellnummer
WFB20-12	ER20 M	30	12	28	46	WFB.220.046MINI
WFB20-12	ER20 M	30	12	28	56	WFB.220.056MINI
WFB20-12	ER20	29	12	34	36	WFB.220.036K
WFB20-12	ER25 M	30	12	35	43	WFB.225.043MINI
WFB20-12	ER25	30	12	42	43	WFB.225.043
WFB24-16	ER11 M	40	16	16	42	WFB.211.042MINI
WFB24-16	ER11	40	16	19	6	WFB.211.006
WFB24-16	ER11	40	16	19	21	WFB.211.021
WFB24-16	ER16 A	40	16	24	16	WFB.216.A16
WFB24-16	ER16	40	16	28	30	WFB.216.030
WFB24-16	ER20 A	40	16	28	30	WFB.220.A30
WFB32-20	ER11 M	50	20	16	67	WFB.311.067MINI
WFB32-20	ER11	50	20	19	24	WFB.311.025T
WFB32-20	ER16 A	50	20	24	10	WFB.316.A10T
WFB32-20	ER16 A	50	20	24	16	WFB.316.A16
WFB32-20	ER16	50	20	28	36	WFB.316.038
WFB32-20	ER16	50	20	28	160	WFB.316.160
WFB32-20	ER20 A	50	20	28	16	WFB.320.A16
WFB32-20	ER25 A	50	20	32	36	WFB.325.A36
WFB32-20	ER25	50	20	42	28	WFB.325.028
WFB32-20	ER25	50	20	42	40	WFB.325.040
WFB32-20	ER32	50	20	50	42	WFB.332.042
WFB 40-25	ER16	63	25	28	35	WFB.416.035
WFB 40-25	ER16	63	25	28	50	WFB.416.050
WFB 40-25	ER25	63	25	42	40	WFB.425.040
WFB 40-25	ER25	63	25	32	27	WFB.425.A27
WFB 40-25	ER32	63	25	50	44	WFB.432.044
WFB 40-25	ER32	63	25	40	43	WFB.432.A43
WFB 40-25	ER40	63	25	63	44	WFB.440.044
WFB 50-32	ER11	75	32	19	37	WFB.511.037
WFB 50-32	ER11	75	32	16	67	WFB.511.067MINI
WFB 50-32	ER16	75	32	28	37	WFB.516.037
WFB 50-32	ER16	75	32	24	10	WFB.516.A10
WFB 50-32	ER32	75	32	50	37	WFB.532.037
WFB 50-32	ER32	75	32	40	43	WFB.532.A43
WFB 50-32	ER40	75	32	63	52	WFB.540.052
WFB 50-32	ER40	75	32	50	50	WFB.540.A50

A* = Innenliegende Spannmutter / Internal collet nut

M* = Mini Spannmutter / Mini-collet nut

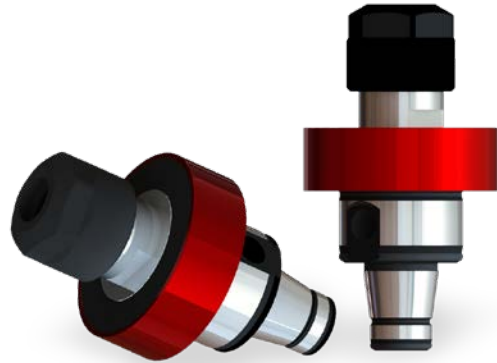
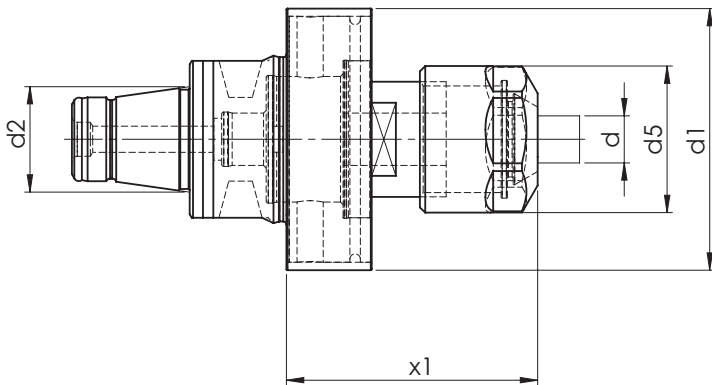

Gewindebohrer DIN374 / DIN376	Gewindebohrer DIN371	Schaft Ø D (mm)	Einstecktiefe E (mm)	Zangen- type
M6	M4	4,5	29	ER-GB
M8	M4,5 - M6	6	31	ER-GB
M10	M7	7	31	ER-GB
-	M8	8	36	ER-GB
M12	-	9	48	ER
-	M10	10	43	ER

Technische Details

Technical specifications

Spannbereich: Ø 4,5 - 10,0 mm für Gewindebohrer M4 - M12.
Range of clamping: Ø 4,5 - 10,0 mm for screw tap M4 - M12.

Längenausgleich auf Druck/Zug: 0,5 mm.
Length compensation on pressure and tension.

Kühlmitteldruck: max. 70 Bar.
Coolant pressure: max. 70 bar.

Kühlmittelzufuhr durch das Zentrum.
Coolant supply through the middle.

Size Größe	Type Typ	[mm] d1	[mm] d2	[mm] d5	[mm] x1	Order no. Bestellnummer
WFB20-12	ER11	30	12	16	32,5	WFB.G20.M8
WFB24-16	ER11	40	16	16	30,5	WFB.G24.M8
WFB32-20	ER16	50	20	28	48	WFB.G32.M12
WFB32-20	ER32	50	20	34	48	WFB.G32.M20
WFB 40-25	ER16	63	25	28	48	WFB.G40.M12
WFB 40-25	ER32	63	25	34	48	WFB.G40.M20
WFB 50-32	ER16	75	32	28	48	WFB.G50.M12

WFB - Hydro-Dehnspannfutter

WFB - Hydraulic expansion chuck

WG 35



Werkzeugtechnik

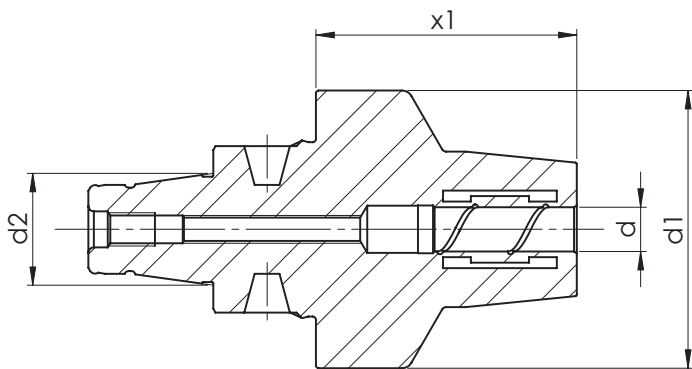

Size Größe	[mm] d	[mm] d1	[mm] d2	[mm] x1	Order no. Bestellnummer
WFB20-12	6	30	12	39	WFB.206.039HDST
WFB20-12	8	30	12	39	WFB.208.039HDST
WFB20-12	10	30	12	39	WFB.210.039HDST
WFB32-20	6	50	20	24	WFB.306.024HDST
WFB32-20	8	50	20	24	WFB.308.024HDST
WFB32-20	10	50	20	29	WFB.310.029HDST
WFB32-20	12	50	20	34	WFB.312.034HDST
WFB32-20	14	50	20	34	WFB.314.034HDST
WFB32-20	16	50	20	42	WFB.316.042HDST
WFB 40-25	10	63	25	10	WFB.410.015HDST

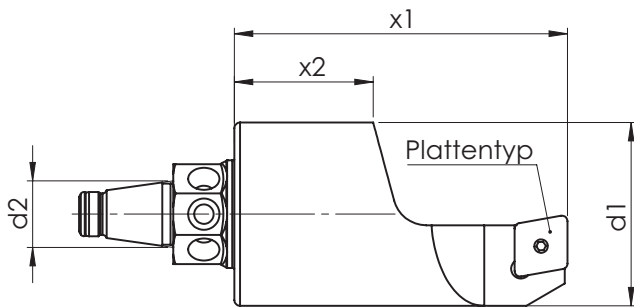

Type	Form
Typ	Form
C09	
D11	
V11	

Size	Type	[mm]	[mm]	[mm]	[mm]	Order no.
Größe	Typ	d1	d2	x1	x2	Bestellnummer
WFB20-12	C09	33	12	60	25	WFB.2DH.C09/L
WFB20-12	C09	33	12	60	25	WFB.2DH.C09/R
WFB20-12	D11	33	12	60	25	WFB.2DH.D11/L
WFB20-12	D11	33	12	60	25	WFB.2DH.D11/R
WFB20-12	V11	33	12	60	25	WFB.2DH.V11/L
WFB20-12	V11	33	12	35	10	WFB.2DH.V11.R.X=35
WFB20-12	V11	33	12	60	25	WFB.2DH.V11/R
WFB32-20	C09	50	20	80	25	WFB.3DH.C09/R
WFB32-20	D11	50	20	80	25	WFB.3DH.D11/R
WFB32-20	V11	50	20	80	25	WFB.3DH.V11/R

Lieferung erfolgt ohne Schneidwerkzeuge

Delivery without cutting tools

WFB-Klemmhalter W-T HORN Mini mit IKZ

WFB - Toolholder W-T HORN Mini with internal cooling system

WG 35

WF
&

Werkzeugtechnik

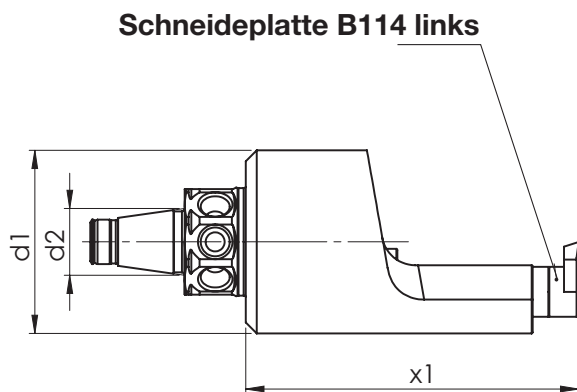

Size Größe	Type Typ	[mm] d1	[mm] d2	[mm] x1	Order no. Bestellnummer
WFB20-12	114	33	12	60	WFB.2HO.114
WFB32-20	114	50	20	80	WFB.3HO.114

Lieferung erfolgt ohne Schneidwerkzeuge
Delivery without cutting tools



Werkzeugtechnik

WFB-Klemmhalter W-T HORN Supermini[®] mit IKZ

WFB - Toolholder W-T HORN Supermini[®] with internal cooling system

WG 35

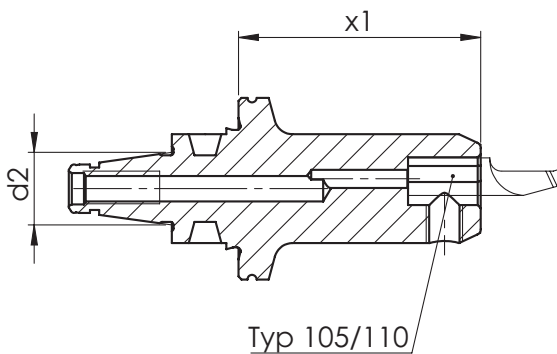

Size Größe	Type Typ	[mm] d1	[mm] d2	[mm] x1	Order no. Bestellnummer
WFB20-12	105	18	12	40	WFB.2HO.105
WFB20-12	105	18	12	55	WFB.2HO.105.055
WFB20-12	110	20	12	40	WFB.2HO.110
WFB32-20	105	50	20	40	WFB.3HO.105
WFB32-20	105	50	20	55	WFB.3HO.105.055
WFB32-20	110	50	20	40	WFB.3HO.110

Lieferung erfolgt ohne Schneidwerkzeuge

Delivery without cutting tools

WFB - HORN Fräuserschaft mit IKZ

WFB - HORN milling shank with internal cooling

WG 35

WF
&

Werkzeugtechnik

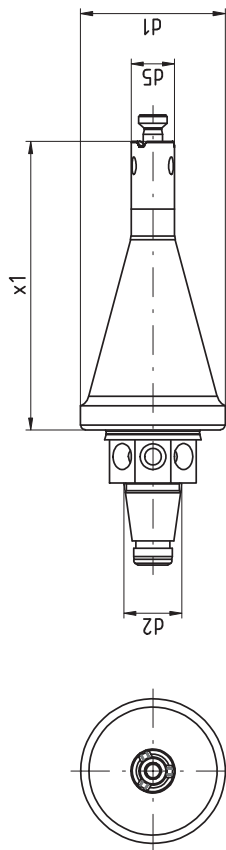

Size Größe	Type Typ	[mm] d1	[mm] d2	[mm] d5	[mm] x1	Order no. Bestellnummer
WFB20-12	311/611	30	12	9	60	WFB.2HO.M311.060
WFB20-12	313/613	30	12	13,3	60	WFB.2HO.M313.060

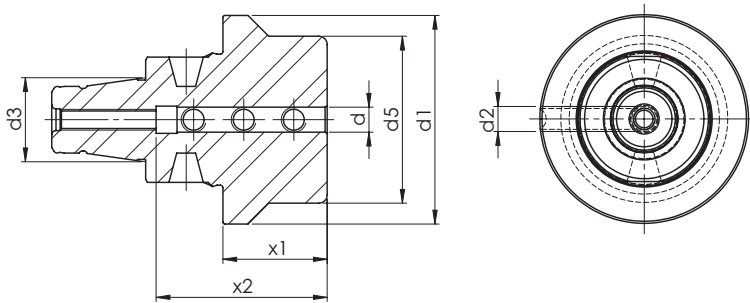

Size Größe	[mm] d	[mm] d1	[mm] d2	[mm] d3	[mm] d5	[mm] x1	[mm] x2	Order no. Bestellnummer
WFB20-12	3	30	M3	12	18	40	15	WFB.2E0.003
WFB20-12	4	30	M4	12	18	40	15	WFB.2E0.004
WFB20-12	5	30	M5	12	18	40	41	WFB.2E0.005
WFB20-12	6	30	M6	12	18	40	41	WFB.2E0.006
WFB20-12	8	30	M6	12	22	40	41	WFB.2E0.008
WFB20-12	10	30	M6	12	22	40	41	WFB.2E0.010
WFB20-12	12	30	M8	12	30	40	35	WFB.2E0.012
WFB20-12	16	30	M8	12	30	40	35	WFB.2E0.016
WFB20-12	20	30	M8	12	33	40	35	WFB.2E0.020
WFB20-12	1/4"	30	M6	12	18	40	30	WFB.2E0.1/4
WFB20-12	1/8"	30	M3	12	18	40	25	WFB.2E0.1/8
WFB20-12	3/16"	30	M4	12	18	40	25	WFB.2E0.3/16
WFB20-12	3/4"	30	M8	12	33	40	35	WFB.2E0.019
WFB32-20	6	50	M6	20	40	25	41	WFB.3E2.006
WFB32-20	8	50	M6	20	40	25	41	WFB.3E2.008
WFB32-20	10	50	M6	20	40	25	41	WFB.3E2.010
WFB32-20	12	50	M8x1	20	40	25	41	WFB.3E2.012
WFB32-20	16	50	M8x1	20	40	25	41	WFB.3E2.016
WFB32-20	20	50	M8x1	20	50	40	41	WFB.3E2.020
WFB32-20	25	50	M8x1	20	50	55	51	WFB.3E2.025
WFB 40-25	6	63	M6	25	40	25	41	WFB.4E2.006
WFB 40-25	8	63	M6	25	40	25	41	WFB.4E2.008
WFB 40-25	10	63	M6	25	40	25	41	WFB.4E2.010
WFB 40-25	12	63	M8x1	25	40	25	41	WFB.4E2.012
WFB 40-25	16	63	M8x1	25	40	25	41	WFB.4E2.016
WFB 40-25	20	63	M8x1	25	40	25	41	WFB.4E2.020
WFB 40-25	25	63	M8x1	25	50	46	51	WFB.4E2.025
WFB 40-25	32	63	M8x1	25	60	65	61	WFB.4E2.032

WFB - Aufsteckfräserdorne mit IKZ

WFB - Milling machine arbors with internal cooling system

WG 35



Werkzeugtechnik

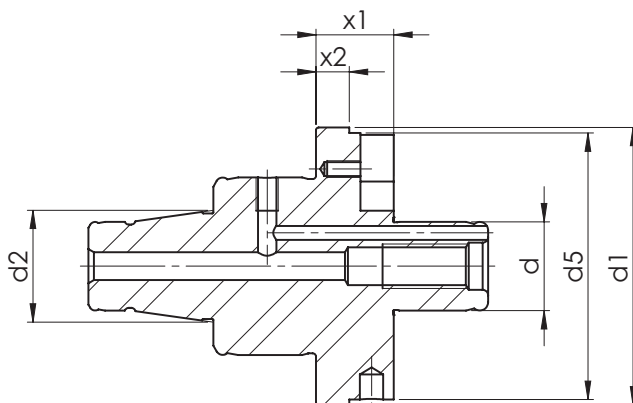

Verwendung: Zur Aufnahme von Fräsern mit Quernut

Lieferumfang: Mit eingebauten Mitnehmersteinen und Fräseranzugschraube

Application: For cutters with key drive

Scope of supply: With driver and cruciform screw

Size Größe	[mm] d	[mm] d1	[mm] d2	[mm] d5	[mm] x1	mm x2	Order no. Bestellnummer
WFB24-16	16	40	16	30	14	5	WFB.16A.2414
WFB32-20	13	50	20	20	14	6	WFB.13A.3214
WFB32-20	16	50	20	40	14	6	WFB.16A.3214
WFB32-20	22	50	20	48	9	6	WFB.22A.3209T
WFB32-20	22	50	20	48	14	6	WFB.22A.3214
WFB32-20	27	50	20	55	14	6	WFB.27A.3214
WFB 40-25	16	63	25	40	14	6	WFB.16A.4014
WFB 40-25	16	63	25	40	36	6	WFB.16A.4036
WFB 40-25	22	63	25	48	14	6	WFB.22A.4014
WFB 40-25	27	63	25	55	20	6	WFB.27A.4020
WFB 50-32	16	75	32	40	14	6	WFB.16A.5014
WFB 50-32	22	75	32	48	14	6	WFB.22A.5014
WFB 50-32	27	75	32	55	14	6	WFB.27A.5014
WFB 50-32	32	75	32	58	15	6	WFB.32A.5015
WFB 50-32	40	75	32	70	15	6	WFB.40A.5015

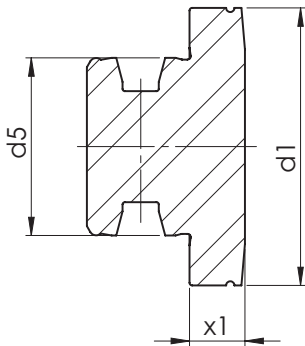

Size Größe	[mm] d1	[mm] d2	[mm] x1	Order no. Bestellnummer
WFB20-12	29	20	10	WFB.212.000K
WFB20-12	30	20	10	WFB.212.000
WFB24-16	40	24	10	WFB.241.200
WFB32-20	50	32	10	WFB.320.000
WFB 40-25	63	40	10	WFB.425.000
WFB 50-32	75	50	10	WFB.532.000

WFB - Reduzierungen / Verlängerungen

WFB - Reductions / Extensions

WG 35

WF
&

Werkzeugtechnik

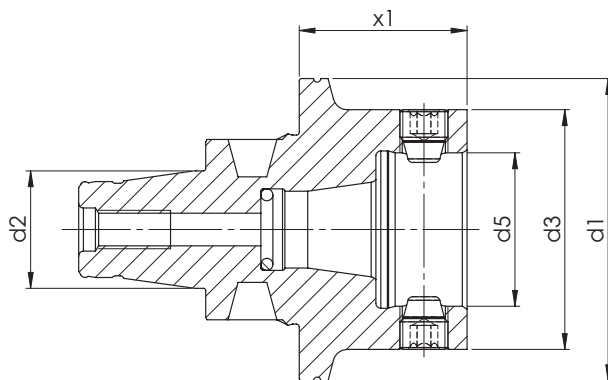

Size Größe	[mm] d1	[mm] d2	[mm] d3	[mm] d5	[mm] x1	Order no. Bestellnummer
WFB20-12	30	12	30	20	20	WFB.V20.020
WFB20-12	30	12	30	20	33,5	WFB.V20.033,5
WFB24-16	40	16	30	20	10	WFB.R24.B20
WFB32-20	50	20	30	20	15	WFB.R32.B20
WFB32-20	50	20	40	24	15	WFB.R32.B24
WFB40-25	63	25	50	32	35	WFB.R40.B32
WFB50-32	75	32	50	32	20	WFB.R50.B32

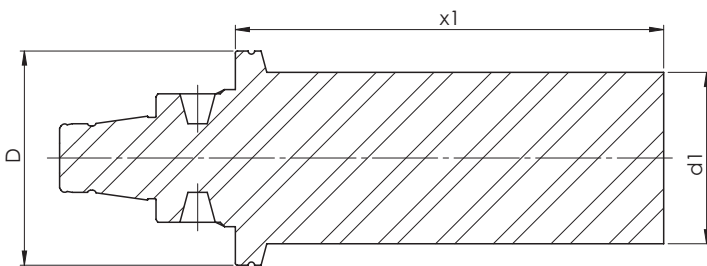

Verwendung: Zur Abnahme von Werkzeugmaschinen gemäß ISO-Empfehlung R230 oder zur Überprüfung der Werkzeugspindel

Application: For machine tools according to ISO recommendations R230 or for testing the tool spindle

Size Größe	[mm] D	[mm] d1	[mm] x1	Order no. Bestellnummer
WFB20-12	30	16	60	WFB.KD1.060
WFB20-12	29	16	60	WFB.KD1.060K
WFB24-16	40	20	80	WFB.KD2.080
WFB32-20	50	40	100	WFB.KD3.100
WFB 40-25	63	40	120	WFB.KD4.120
WFB 50-32	75	40	160	WFB.KD5.160

WFB - Bohrstangen-Rohlinge

WFB - Boring bar-blanks

WG 35



Werkzeugtechnik

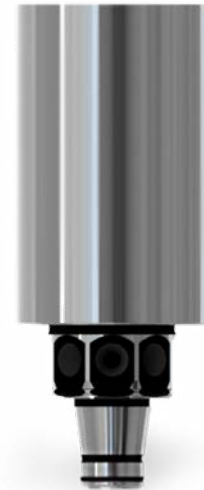
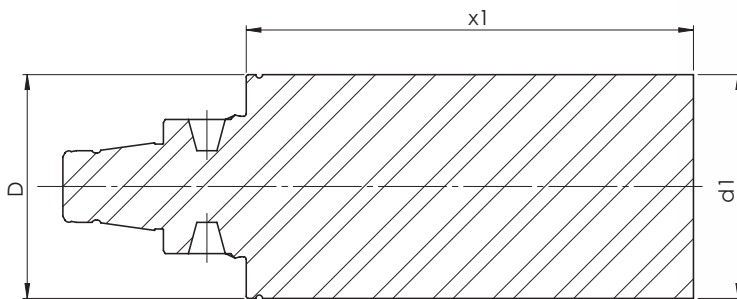

Size Größe	[mm] d	[mm] d1	[mm] x1	Order no. Bestellnummer
WFB20-12	30	33	60	WFB.R20.X6S*
WFB20-12	30	22	60	WFB.R22.060
WFB24-16	40	45	80	WFB.R24.045.080.SX
WFB32-20	50	22	60	WFB.R32.022.060.SX
WFB32-20	50	50	80	WFB.R32.X8S
WFB32-20	50	50	100	WFB.R32.050.100.SX

* Material: 31CrMoV9

Spannzangen-Sätze mit Holzsockel System ER / ESX

Collets System ER / ESX in wooden board

WG 35

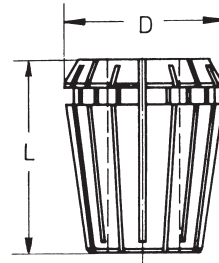

	D	L
426 E	17	27
428 E	21	31,5
430 E	26	34
470 E	33	40
472 E	41	46

ER 40 (3-26) 472 E

23 Spannzangen
4-26 mm Ø, 1 mm gestuft

Art. Nr. 12.326.OHS

Art. Nr. 12.326.OHS.EP

zusätzlich (wie Abbildung)
gegen Mehrpreis
1 Spannzange mit 3 mm Ø

Art. Nr. 12.326.030

Art. Nr. 12.326.030EP

ER 32 (2-20) 470 E

18 Spannzangen
3-20 mm Ø, 1 mm gestuft

Art. Nr. 12.220.OHS

Art. Nr. 12.220.OHS.EP

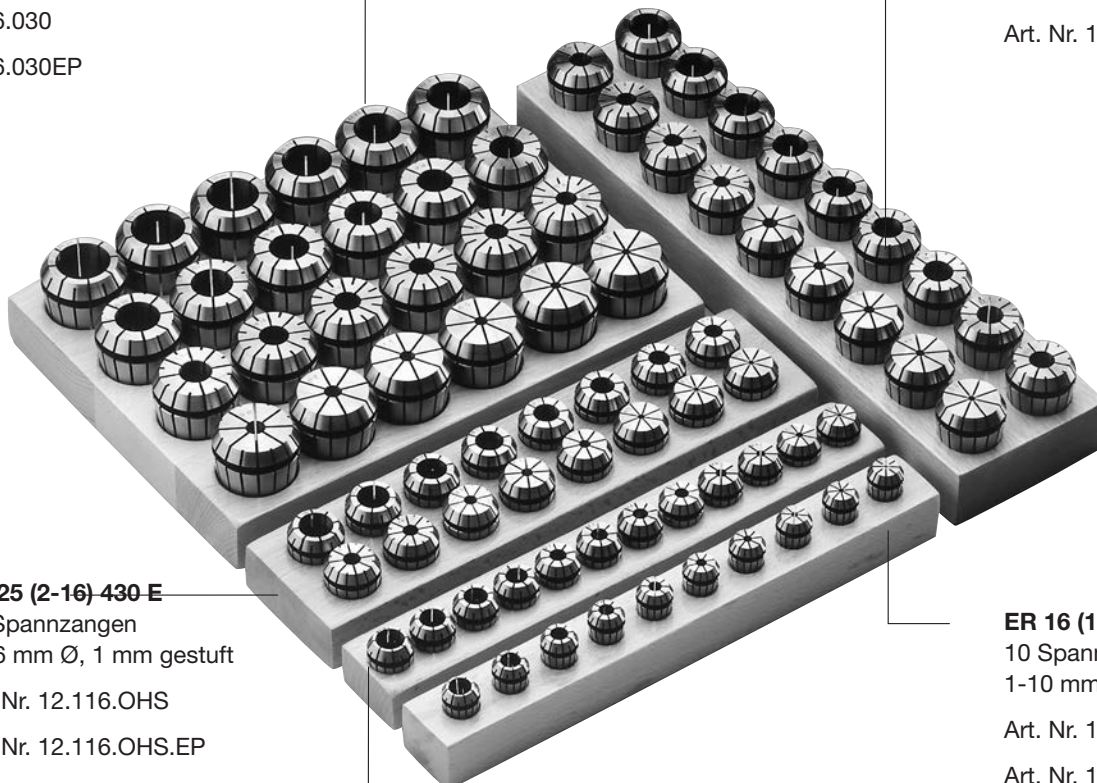

ER 25 (2-16) 430 E

15 Spannzangen
2-16 mm Ø, 1 mm gestuft

Art. Nr. 12.116.OHS

Art. Nr. 12.116.OHS.EP

zusätzlich (wie Abbildung)
gegen Mehrpreis
1 Spannzange mit 1 mm Ø

Art. Nr. 12.116.010

Art. Nr. 12.116.010EP

ER 20 (2-13) 428 E

12 Spannzangen
2-13 mm Ø, 1 mm gestuft

Art. Nr. 12.113.OHS

Art. Nr. 12.113.OHS.EP

ER 16 (1-10) 426 E

10 Spannzangen
1-10 mm Ø, 1 mm gestuft

Art. Nr. 12.110.OHS

Art. Nr. 12.110.OHS.EP

EP: Extra Präzision - Rundlauf <math><5\mu</math>

EP: extra precision - runout <math><5\mu</math>

Spannzangen System ER / ESX ER11 / ER16 / ER20

Collets System ER / ESX

WG 11



Werkzeugtechnik

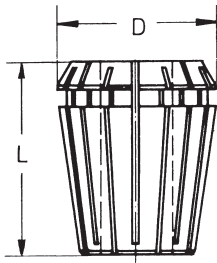

	D	L
424 E	11,5	18
426 E	17	27
428 E	21	31,5

Ø	Order no. Bestellnummer
ER 11 (1 – 8) 424 E	
1,0	12.107.010
1,5	12.107.015
2,0	12.107.020
2,5	12.107.025
3,0	12.107.030
3,5	12.107.035
4,0	12.107.040
4,5	12.107.045
5,0	12.107.050
5,5	12.107.055
6,0	12.107.060
6,5	12.107.065
7,0	12.107.070
8,0	12.107.080*

Ø	Order no. Bestellnummer
ER 16 (1 – 12) 426 E	
1,0	12.110.010
1,5	12.110.015
2,0	12.110.020
2,5	12.110.025
3,0	12.110.030
3,5	12.110.035
4,0	12.110.040
4,5	12.110.045
5,0	12.110.050
5,5	12.110.055
6,0	12.110.060
6,5	12.110.065
7,0	12.110.070
7,5	12.110.075
8,0	12.110.080
8,5	12.110.085
9,0	12.110.090
9,5	12.110.095
10,0	12.110.100
10,5	12.110.105*
11,0	12.110.110*
11,5	12.110.115*
12,0	12.110.120*

Ø	Order no. Bestellnummer
ER 20 (1,0 – 15) 428 E	
1,0	12.113.010*
2,0	12.113.020
3,0	12.113.030
4,0	12.113.040
5,0	12.113.050
6,0	12.113.060
7,0	12.113.070
8,0	12.113.080
9,0	12.113.090
10,0	12.113.100
11,0	12.113.110
12,0	12.113.120
13,0	12.113.130
13,5	12.113.135*
14,0	12.113.140*
14,5	12.113.145*
15,0	12.113.150*

*Sondergröße
Special size



Werkzeugtechnik

Spannzangen System ER / ESX ER25 / ER32 / ER40

Collets System ER / ESX

WG 11

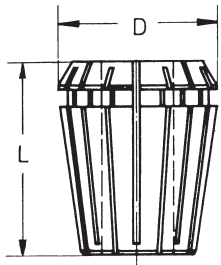

	D	L
430 E	26	34
470 E	33	40
472 E	41	46

Ø	Order no. Bestellnummer
ER 25 (1 – 20) 430 E	
1,0	12.116.010*
2,0	12.116.020
3,0	12.116.030
4,0	12.116.040
5,0	12.116.050
6,0	12.116.060
7,0	12.116.070
8,0	12.116.080
9,0	12.116.090
10,0	12.116.100
11,0	12.116.110
12,0	12.116.120
13,0	12.116.130
14,0	12.116.140
15,0	12.116.150
16,0	12.116.160
16,5	12.116.165*
17,0	12.116.170*
17,5	12.116.175*
18,0	12.116.180*
18,5	12.116.185*
19,0	12.116.190*
19,5	12.116.195*
20,0	12.116.200*

Ø	Order no. Bestellnummer
ER 32 (2 – 22) 470 E	
2,0	12.220.020*
3,0	12.220.030
4,0	12.220.040
5,0	12.220.050
6,0	12.220.060
7,0	12.220.070
8,0	12.220.080
9,0	12.220.090
10,0	12.220.100
11,0	12.220.110
12,0	12.220.120
13,0	12.220.130
14,0	12.220.140
15,0	12.220.150
16,0	12.220.160
17,0	12.220.170
18,0	12.220.180
19,0	12.220.190
20,0	12.220.200
21,0	12.220.210*
22,0	12.220.220*

Ø	Order no. Bestellnummer
ER 40 (3 – 30) 472 E	
3,0	12.326.030*
4,0	12.326.040
5,0	12.326.050
6,0	12.326.060
7,0	12.326.070
8,0	12.326.080
9,0	12.326.090
10,0	12.326.100
11,0	12.326.110
12,0	12.326.120
13,0	12.326.130
14,0	12.326.140
15,0	12.326.150
16,0	12.326.160
17,0	12.326.170
18,0	12.326.180
19,0	12.326.190
20,0	12.326.200
21,0	12.326.210
22,0	12.326.220
23,0	12.326.230
24,0	12.326.240
25,0	12.326.250
26,0	12.326.260
27,0	12.326.270*
28,0	12.326.280*
29,0	12.326.290*
30,0	12.326.300*

*Sondergröße
Special size

Spannzangen System ER / ESX ER11 / ER16 / ER20

Collets System ER / ESX

WG 11



Werkzeugtechnik

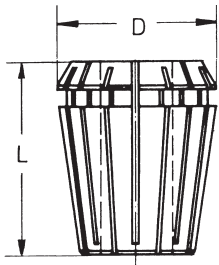

	D	L
424 E	11,5	18
426 E	17	27
428 E	21	31,5

Ø	Order no. Bestellnummer
ER 11 (1 – 8) 424 E	
1,0	12.107.010.EP
1,5	12.107.015.EP
2,0	12.107.020.EP
2,5	12.107.025.EP
3,0	12.107.030.EP
3,5	12.107.035.EP
4,0	12.107.040.EP
4,5	12.107.045.EP
5,0	12.107.050.EP
5,5	12.107.055.EP
6,0	12.107.060.EP
6,5	12.107.065.EP
7,0	12.107.070.EP
8,0	12.107.080.EP*

Ø	Order no. Bestellnummer
ER 16 (1 – 12) 426 E	
1,0	12.110.010.EP
1,5	12.110.015.EP
2,0	12.110.020.EP
2,5	12.110.025.EP
3,0	12.110.030.EP
3,5	12.110.035.EP
4,0	12.110.040.EP
4,5	12.110.045.EP
5,0	12.110.050.EP
5,5	12.110.055.EP
6,0	12.110.060.EP
6,5	12.110.065.EP
7,0	12.110.070.EP
7,5	12.110.075.EP
8,0	12.110.080.EP
8,5	12.110.085.EP
9,0	12.110.090.EP
9,5	12.110.095.EP
10,0	12.110.100.EP
10,5	12.110.105.EP*
11,0	12.110.110.EP*
11,5	12.110.115.EP*
12,0	12.110.120.EP*

Ø	Order no. Bestellnummer
ER 20 (1,0 – 15) 428 E	
1,0	12.113.010.EP*
2,0	12.113.020.EP
3,0	12.113.030.EP
4,0	12.113.040.EP
5,0	12.113.050.EP
6,0	12.113.060.EP
7,0	12.113.070.EP
8,0	12.113.080.EP
9,0	12.113.090.EP
10,0	12.113.100.EP
11,0	12.113.110.EP
12,0	12.113.120.EP
13,0	12.113.130.EP
13,5	12.113.135.EP*
14,0	12.113.140.EP*
14,5	12.113.145.EP*
15,0	12.113.150.EP*

***Sondergröße**

Special size

EP: Extra Präzision - Rundlauf <5µ

EP: extra precision - runout <5µ



Werkzeugtechnik

Spannzangen System ER / ESX ER25 / ER32 / ER40

Collets System ER / ESX

WG 11

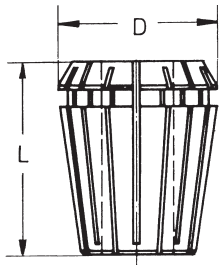

	D	L
430 E	26	34
470 E	33	40
472 E	41	46

Ø	Order no. Bestellnummer
ER 25 (1 – 20) 430 E	
1,0	12.116.010.EP*
2,0	12.116.020.EP
3,0	12.116.030.EP
4,0	12.116.040.EP
5,0	12.116.050.EP
6,0	12.116.060.EP
7,0	12.116.070.EP
8,0	12.116.080.EP
9,0	12.116.090.EP
10,0	12.116.100.EP
11,0	12.116.110.EP
12,0	12.116.120.EP
13,0	12.116.130.EP
14,0	12.116.140.EP
15,0	12.116.150.EP
16,0	12.116.160.EP
16,5	12.116.165.EP*
17,0	12.116.170.EP*
17,5	12.116.175.EP*
18,0	12.116.180.EP*
18,5	12.116.185.EP*
19,0	12.116.190.EP*
19,5	12.116.195.EP*
20,0	12.116.200.EP*

Ø	Order no. Bestellnummer
ER 32 (2 – 22) 470 E	
2,0	12.220.020.EP*
3,0	12.220.030.EP
4,0	12.220.040.EP
5,0	12.220.050.EP
6,0	12.220.060.EP
7,0	12.220.070.EP
8,0	12.220.080.EP
9,0	12.220.090.EP
10,0	12.220.100.EP
11,0	12.220.110.EP
12,0	12.220.120.EP
13,0	12.220.130.EP
14,0	12.220.140.EP
15,0	12.220.150.EP
16,0	12.220.160.EP
17,0	12.220.170.EP
18,0	12.220.180.EP
19,0	12.220.190.EP
20,0	12.220.200.EP
21,0	12.220.210.EP*
22,0	12.220.220.EP*

Ø	Order no. Bestellnummer
ER 40 (3 – 30) 472 E	
3,0	12.326.030.EP*
4,0	12.326.040.EP
5,0	12.326.050.EP
6,0	12.326.060.EP
7,0	12.326.070.EP
8,0	12.326.080.EP
9,0	12.326.090.EP
10,0	12.326.100.EP
11,0	12.326.110.EP
12,0	12.326.120.EP
13,0	12.326.130.EP
14,0	12.326.140.EP
15,0	12.326.150.EP
16,0	12.326.160.EP
17,0	12.326.170.EP
18,0	12.326.180.EP
19,0	12.326.190.EP
20,0	12.326.200.EP
21,0	12.326.210.EP
22,0	12.326.220.EP
23,0	12.326.230.EP
24,0	12.326.240.EP
25,0	12.326.250.EP
26,0	12.326.260.EP
27,0	12.326.270.EP*
28,0	12.326.280.EP*
29,0	12.326.290.EP*
30,0	12.326.300.EP*

*Sondergröße
Special size

EP: Extra Präzision - Rundlauf <5µ
EP: extra precision - runout <5µ

WFB - Ersatzteile / Zubehör

WFB - Spare parts / Accessories

WG 11

WF

Werkzeugtechnik



WFB - Kegelnwindstifte
Threaded taper pins

For Size Für Größe	Order no. Bestellnummer
WFB20-12	WFS.M6x0,75.TORX 15 Plus
WFB20-12	WFS.M6x1.TORX
WFB24-16	WFS.M8x1.TORX
WFB32-20	WFS.M10x1x11
WFB40-25	WFS.M12X1
WFB50-32	WFS.M14x1



Drehmoment-Schraubendreher auf Anfrage lieferbar!
Torque screwdriver on request available!

For Size Für Größe	Order no. Bestellnummer
WFB20-12	WFB.020.T15.PLUS



Drehmomentset
Torque set

For Size Für Größe	Order no. Bestellnummer
WFB20-12/24-16	WF.88103001000



Werkzeugtechnik

Allgemeine Verkaufs- und Lieferbedingungen

General sales terms and delivery conditions

1. Angebot, Vertragsabschluss und Vertragsinhalt

Allen Vertragsabschlüssen, betreffend Lieferung und Leistungen von uns, liegen die nachfolgenden Bedingungen zugrunde. Sie werden vom Besteller mit Auftragserteilung, spätestens mit der Annahme der ersten Lieferung/Leistung anerkannt und gelten für die gesamte Dauer der Geschäftsbeziehung. Abweichende Einkaufsbedingungen des Bestellers gelten nur mit unserer schriftlichen Zustimmung.

Der Vertrag kommt erst mit unserer schriftlichen Bestätigung und entsprechend deren Inhalt und durch Lieferung/Leistung zustande. Erfolgt ohne eine Bestätigung unverzüglich Lieferung/Leistung, so gilt die Rechnung gleichzeitig als Auftragsbestätigung.

2. Bestellwert

Bei einem Bestellwert unter € 100,- kommen keine Rabatte in Anrechnung. Der Mindestbestellwert beträgt € 60,- netto.

3. Preis und Zahlung

Die Preise gelten mangels besonderer Vereinbarung ab Werk einschl. Verladung im Werk, jedoch ausschließlicher Verpackung. Zu den Preisen kommt die Mehrwertsteuer in der jeweiligen gesetzlichen Höhe hinzu.

Mangels besonderer Vereinbarung ist die Zahlung ohne jeden Abzug frei Zahlstelle des Lieferanten innerhalb von 30 Tagen nach Rechnungsdatum (auch bei Teillieferung) zu leisten.

Die Zurückhaltung von Zahlungen oder die Aufrechnung wegen etwaiger vom Lieferer bestrittener Gegenansprüche des Bestellers sind nicht statthaft.

4. Eigentumsvorbehalt

Die gelieferten Waren bleiben unser Eigentum (Vorbehaltsware) bis zur Erfüllung sämtlicher uns gegen den Besteller aus der Geschäftsverbindung zustehenden Ansprüche.

Die Verarbeitung der Vorbehaltsware ist dem Besteller im Rahmen des regelmäßigen Geschäftsbetriebs gestattet. Die Verarbeitung der Ware erfolgt für uns. Wir erwerben in allen Fällen das Eigentum an den neu hergestellten Sachen; eine Verpflichtung entsteht für uns hieraus nicht. Der Besteller hat die in unserem (Mit-)Eigentum stehenden Waren für uns unentgeltlich zu verwahren. Bei Verarbeitung mit Waren an denen wir kein Eigentum besitzen erwerben wir Miteigentum an den neu hergestellten Sachen nach dem Verhältnis des Rechnungswertes der Vorbehaltsware zu den anderen verarbeiteten Gegenständen. Sollte unser Eigentum dennoch untergehen und der Besteller (Mit-)Eigentümer werden, so überträgt er bereits jetzt sein Eigentum nach dem vorab bezeichneten Wertverhältnis als Sicherheit auf uns.

Der Besteller ist zu Weiterveräußerung der Vorbehaltsware im Rahmen seines regelmäßigen Geschäftsbetriebs nur unter der Bedingung berechtigt, dass er sich seinerseits das Eigentum bis zur vollständigen Zahlung des Kunden vorbehält. Die Veräußerungsermächtigung erlischt automatisch bei einem fruchtlosen Zwangsvollstreckungsversuch beim Besteller, sowie bei Stellung eines Antrags auf Eröffnung des Insolvenzverfahrens über das Vermögen des Bestellers. Andere Verfügungen über die Vorbehaltsware, insbesondere Verpfändung und Sicherungsübereignung sind unzulässig.

Der Besteller tritt bereits jetzt alle aus der Weiterveräußerung der Vorbehaltsware in verarbeitetem und unverarbeitetem Zustand entstehenden Forderungen mit allen Nebenrechten – einschließlich etwaiger Saldoforderungen – sicherungshalber an uns ab, ohne dass es noch späterer besonderer Erklärungen bedarf. Veräußert der Besteller verarbeitete, verbundene oder vermischte Vorbehaltsware, ohne dass eine Einzelpreisvereinbarung für die Vorbehaltsware besteht, so tritt der Besteller uns mit Vorrang vor der übrigen Forderung denjenigen Teil der Gesamtpreisforderung ab, der dem von uns in Rechnung gestellten Preis der Vorbehaltsware entspricht.

Der Besteller ist verpflichtet uns unverzüglich über Zwangsvollstreckungsmaßnahmen Dritter in die Vorbehaltsware und in deren sonstige Sicherheiten unter Übergabe der für den Widerspruch notwendigen Unterlagen zu unterrichten.

Der Besteller ist vorbehaltlich des jederzeit möglichen Widerrufs berechtigt, die an uns abgetretenen Forderungen im regelmäßigen Geschäftsbetrieb einzuziehen. Von dieser Ermächtigung nicht erfasst ist die Abtretung der aus der Weiterveräußerung der Waren resultierenden Forderungen an ein Factoring-Institut im Rahmen eines sog. „echten“ Factorings unter Übernahme des Delkredererisikos. Vorsorglich tritt der Besteller seine Rechte gegen das Factoring-Institut auf Auszahlung des Factoring Erlöses an uns ab und verpflichtet sich, dem Factoring-Institut unverzüglich nach Rechnungsstellung durch uns diese Abtretung anzuzeigen. Wir werden von unserer Einziehungsbefugnis keinen Gebrauch machen, solange der Besteller seinen Zahlungsverpflichtungen vereinbarungsgemäß nachkommt.

Der Besteller verpflichtet sich bei Zugriffen Dritter auf die Vorbehaltsware, wie z.B. Pfändungen, uns sofort zu unterrichten um uns die Durchsetzung unserer Eigentumsrechte zu ermöglichen und auf unser daran bestehendes Eigentum hinzuweisen.

5. Lieferzeit

Angegebene Lieferzeiten sind, sofern nicht individuell vereinbart, unverbindlich.

6. Mängelrüge

Erkennbare Mängel sind unverzüglich nach Empfang der Lieferung/Leistung, versteckte Mängel unverzüglich nach Entdeckung schriftlich zu rügen. Mängelrüge ist verspätet, wenn sie nicht spätestens 8 Tage nach Empfang der Lieferung/Leistung bzw. bei versteckten Mängeln nach Entdeckung des Mangels bei uns eingegangen ist. Wenn eine Mängelrüge begründet geltend gemacht wird, dürfen Zahlungen nur im Umfang zurückgehalten werden, die in einem angemessenen Verhältnis zu dem aufgetretenen Mangel stehen.

7. Gewährleistung und Haftung

Wir haften für rechtzeitig gerügte Mängel, zu denen auch das Fehlen zugesicherter Eigenschaften gehört, wie folgt:

– Alle diejenigen Teile sind unentgeltlich nach billigem Ermessen nach Wahl des Lieferanten nachzubessern oder neu zu liefern, die sich innerhalb von 6 Monaten (bei Mehrschichtenbetrieb innerhalb von 3 Monaten) seit Lieferung infolge eines vor dem Gefahrenübergang liegenden Umstandes – insbesondere wegen fehlender Bauart, schlechter Werkstoffe oder mangelhafter Ausführung – als nicht unerheblich beeinträchtigt herausstellen. Mehrere Nachbesserungsversuche sind zulässig. Ersetzte Teile werden unser Eigentum.

Für Mängel des vom Besteller angelieferten Materials haften wir nicht. Für wesentliche Fremderzeugnisse beschränkt sich unsere Haftung auf die Abtretung der Haftungsansprüche, die uns gegen den Lieferer des Fremderzeugnisses zustehen.

Bei Fertigung nach Zeichnung des Bestellers haften wir nur für zeichnungsgemäße Ausführung.

– Es wird keine Gewähr übernommen für Schäden, die aus nachfolgenden Gründen entstanden sind:

Ungeeignete und unsachgemäße Verwendung, fehlerhafter Montage bzw. Inbetriebsetzung durch den Besteller oder Dritte, natürliche Abnutzung, fehlerhafte oder nachlässige Behandlung, ungeeignete Betriebsmittel, chemische, elektrochemische oder elektrische Einflüsse, sofern sie nicht auf unser Verschulden zurückzuführen sind. Unsere Gewährleistungspflicht entfällt, wenn von Seiten des Bestellers oder Dritter ohne unsere Zustimmung Instandsetzungen, Beschädigungen oder Änderungen vorgenommen werden, die mit dem geltend gemachten Mangel in Zusammenhang stehen.

8. Rücknahme von Waren

Waren werden nur nach besonderer Vereinbarung zurück genommen – vorbehaltlich folgender Bedingungen:

Die Ware muss in fabriktuem Zustand und aus der laufenden Produktion sein. Eine Lieferschein- oder Rechnungskopie muss der Rücksendung beiliegen.

Für Rücksendungen, die der Besteller zu vertreten hat, wird eine Bearbeitungsgebühr von 15%, mindestens jedoch € 30,- in Abzug gebracht.

Sonderaufnahmen oder speziell auf Kundenwunsch beschriftete Artikel sind vom Umtausch bzw. Rückgabe ausgeschlossen.

9. Haftung für Nebenpflichten, sonstige Haftung

Unsere anwendungstechnische Beratung in Wort und Schrift sowie Vorschläge, Berechnungen, Projektierungen usw. sollen dem Besteller lediglich die bestmögliche Verwendung unserer Produkte erläutern. Sie befreit den Besteller nicht von seiner Verpflichtung, sich durch eigene Prüfung von der Eignung unserer Produkte für den von ihm beabsichtigten Zweck zu überzeugen.

10. Schutzrecht, Werkzeug

An allen unseren Angeboten und Lieferungen beigefügten Abbildungen, Skizzen, Zeichnungen, Lehren, Muster usw. behalten wir uns Eigentums- und Urheberrechte vor. Sie dürfen Dritten ohne unsere ausdrückliche Genehmigung nicht zugänglich gemacht werden. Vervielfältigungen und Nachahmungen sind verboten.

Der Besteller übernimmt für die von ihm beizubringenden Unterlagen, Pläne, Muster oder dergleichen die alleinige Verantwortung. Der Besteller hat dafür einzustehen, dass von ihm vorgelegte Ausführungszeichnungen in Schutzrechte Dritter nicht eingreifen.

11. Erfüllungsort

Erfüllungsort ist 72663 Großbettlingen.

12. Gerichtsstand

Gerichtsstand ist der Sitz des Lieferanten.

13. Änderungsvorbehalt und Teilnichtigkeit

Wir erklären dem Besteller ausdrücklich unsere Bereitschaft, im Wege des freien gegenseitigen Aushandelns die Vertragsklauseln inhaltlich auszugestalten. Sollte eine Bestimmung unserer Verkaufs- und Lieferbedingungen aus irgend einem Grunde nichtig sein, bleibt die Geltung der übrigen Bestimmungen hiervon unberührt. Anstelle einer unwirksamen Regelung gilt das gesetzlich Zulässige.

Stand: April 2007

Modulare Aggregatetechnik

Citizen



Katalog CI-02

Modulare Aggregatetechnik

DMG MORI



Katalog GS-02

Modulare Aggregatetechnik

Hanwha



Katalog HA-02

Modulare Aggregatetechnik

Maier



Katalog MA-02

Modulare Aggregatetechnik

Star



Katalog ST-02

Modulare Aggregatetechnik

TORNOS



Katalog TO-03

Modulare Aggregatetechnik

Gesamtkatalog



Katalog GS-01

Modulare Aggregatetechnik

Doosan



Katalog DO-01

Modulare Aggregatetechnik

Mazak



Katalog MZ-01

Modulare Aggregatetechnik

Mori Seiki



Katalog MS-01

Modulare Aggregatetechnik

Okuma



Katalog OK-01

Modulare Aggregatetechnik

WFB-Adapter



Katalog WFB-02

Modulare Aggregatetechnik

Haas



Katalog HA-01

Modulare Aggregatetechnik

WFE/SHT



Katalog WF-02

Modulare Drehhalter

WF-MICRO

WF-Micro
think future



Katalog MI-02

W&F
Werkzeugtechnik GmbH
 Kantstraße 4
 72663 Großbettlingen

T +49 (0) 7022/4058-0
 F +49 (0) 7022/4058-58
 info@wf-werkzeugtechnik.de
 wf-werkzeugtechnik.de