

**Innendrehhalter HORN Typ 105**  
Internal turning holder HORN type 105

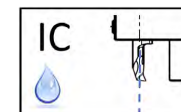

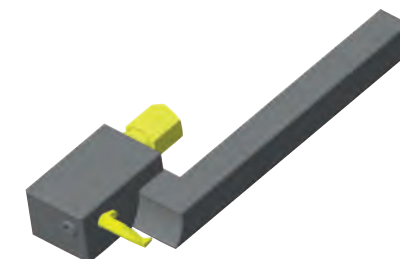

**Anwendungsbereich Innenbearbeitung**  
Range of application internal turning tools

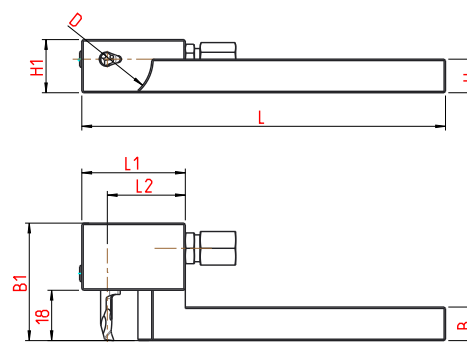

1

Bestell Nummer Order Number	Bezeichnung Description	L	B	H	L1	L2	D	H1	B1	für Wendeplatte for insert
01-1323	962.08.01.R.IK	130	8	8	37	27	30	15	42	HORN Typ 105
01-1324	962.08.02.L.IK	130	8	8	37	27	30	15	42	
01-1325	962.10.01.R.IK	130	10	10	37	27	30	17	42	
01-1326	962.10.02.L.IK	130	10	10	37	27	30	17	42	
01-1327	962.12.01.R.IK	130	12	12	37	27	30	19	42	
01-1328	962.12.02.L.IK	130	12	12	37	27	30	19	42	
01-1329	962.16.01.R.IK	130	16	16	37	27	34	23	42	
01-1330	962.16.02.L.IK	130	16	16	37	27	34	23	42	
01-1331	962.20.01.R.IK	130	20	20	37	27	34	27	42	
01-1332	962.20.02.L.IK	130	20	20	37	27	34	27	42	

Abmessungen in mm  
Dimensions in mm

Ersatzteile / Spare parts	
	
004.00.19	001.01.36

Weitere Größen auf Anfrage  
other sizes on request

**Innendrehhalter HORN Typ 105**  
Internal turning holder HORN type 105

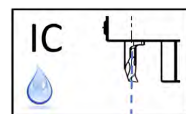

**Anwendungsbereich Innenbearbeitung**  
Range of application interal turning tools

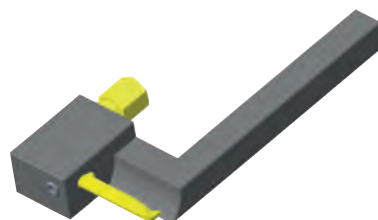
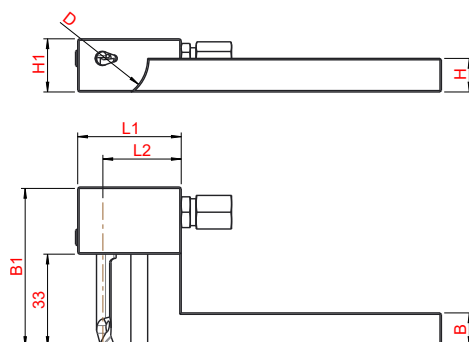

Bestell Nummer Order Number	Bezeichnung Description	L	B	H	L1	L2	D	H1	B1	für.Wendeplatte for insert
01-1333	962.10.03.R.IK	130	10	10	37	27	30	17	57	HORN Typ 105
01-1334	962.10.04.L.IK	130	10	10	37	27	30	17	57	
01-1335	962.12.03.R.IK	130	12	12	37	27	30	19	57	
01-1336	962.12.04.L.IK	130	12	12	37	27	30	19	57	
01-1337	962.16.03.R.IK	130	16	16	37	27	34	23	57	
01-1338	962.16.04.L.IK	130	16	16	37	27	34	23	57	

Abmessungen in mm  
Dimensions in mm

Ersatzteile / Spare parts	
004.00.19	001.01.36

Weitere Größen auf Anfrage  
other sizes on request

**Innendrehhalter HORN Typ 105**  
Internal turning holder HORN type 105

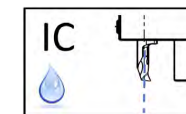

**Anwendungsbereich Innenbearbeitung**  
Range of application interal turning tools

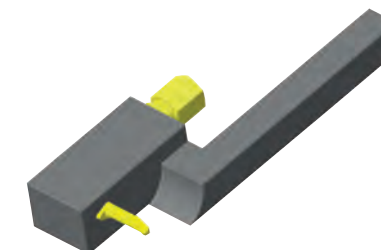
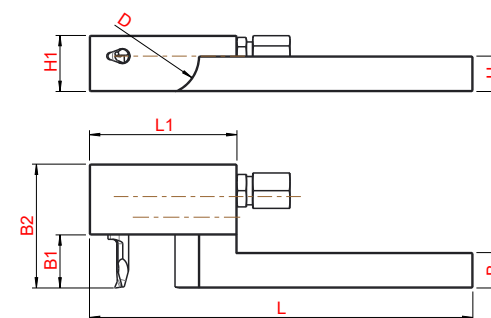

Bestell Nummer Order Number	Bezeichnung Description	L	B	H	L1	B1	D	H1	B2	für Wendeplatte for insert
01-1345	963.12.01.R IK	130	12	12	50	18	46	19	42	HORN Typ 105
01-1346	963.12.02.L IK	130	12	12	50	18	46	19	42	
01-1347	963.16.01.R IK	130	16	16	55	18	52	23	42	
01-1348	963.16.02.L IK	130	16	16	55	18	52	23	42	

Abmessungen in mm  
Dimensions in mm

Ersatzteile / Spare parts	
004.00.19	001.01.36

Weitere Größen auf Anfrage  
other sizes on request

**Wendeplattenhalter HORN Typ 312**  
Turret plate holder HORN type 312

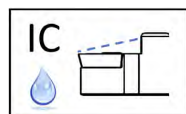

Anwendungsbereich Kopierdrehen, Abstechen  
Range of application copy turning, plunging

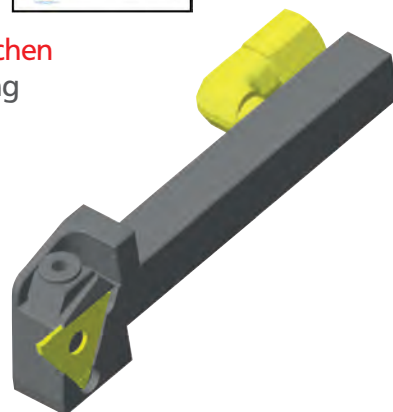
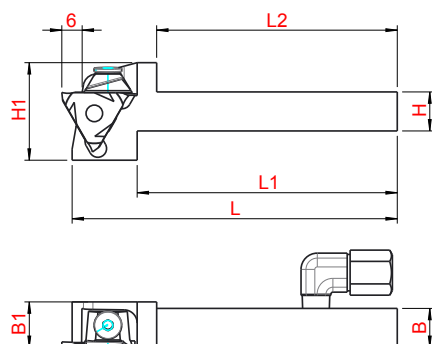

Bestell Nummer Order Number	Bezeichnung Description	L	L1	L2	B	B1	H	H1	für Wendeplatte for insert
01-0566	912.R.1012.01.IK	100	80	74	12	14	10	30	HORN Typ 312 0,5 - 1,9
01-0567	912.L.1012.01.IK	100	80	74	12	14	10	30	
01-0480	912.R.1212.01.IK	100	80	74	12	14	12	30	
01-0460	912.L.1212.01.IK	100	80	74	12	14	12	30	
01-0440	912.R.1616.01.IK	100	80	74	16	16	16	34	
01-0568	912.L.1616.01.IK	100	80	74	16	16	16	34	
01-0469	912.R.1012.02.IK	100	80	74	12	14	10	30	HORN Typ 312 1,9 - 2,9
01-0569	912.L.1012.02.IK	100	80	74	12	14	10	30	
01-0446	912.R.1212.02.IK	100	80	74	12	14	12	30	
01-0529	912.L.1212.02.IK	100	80	74	12	14	12	30	
01-0428	912.R.1616.02.IK	100	80	74	16	16	16	34	
01-0570	912.L.1616.02.IK	100	80	74	16	16	16	34	

Abmessungen in mm  
Dimensions in mm

Ersatzteile / Spare parts	
004.00.22	4117.R
	4156.L

Weitere Größen auf Anfrage  
other sizes on request

**Wendeplattenhalter HORN Typ S 274**  
Turret plate holder HORN type S 274

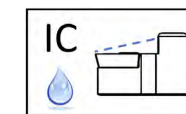

Anwendungsbereich Kopierdrehen, Abstechen  
Range of application copy turning, plunging

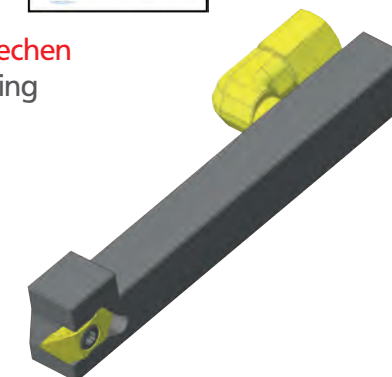
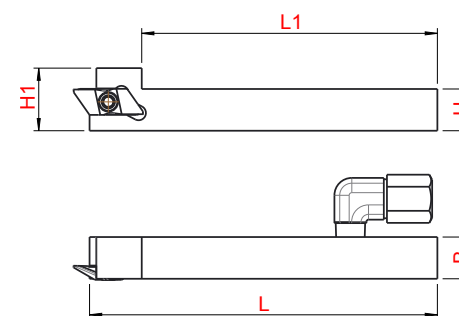

Bestell Nummer Order Number	Bezeichnung Description	L	L1	B	H	B1	für Wendeplatte for insert
01-0522	974.R.1012.04.IK	100	85	10	12	16	HORN Typ S 274
01-0532	974.L.1012.04.IK	100	85	10	12	16	
01-0413	974.R.1212.04.IK	100	85	12	12	18	
01-0414	974.L.1212.04.IK	100	85	12	12	18	
01-0430	974.R.1616.04.IK	100	85	16	16	22	
01-0512	974.L.1616.04.IK	100	85	16	16	22	
01-0438	974.R.2020.04.IK	100	85	20	20	26	
01-0500	974.L.2020.04.IK	100	85	20	20	26	

Abmessungen in mm  
Dimensions in mm

Ersatzteile / Spare parts	
004.00.22	001.01.39

Weitere Größen auf Anfrage  
other sizes on request

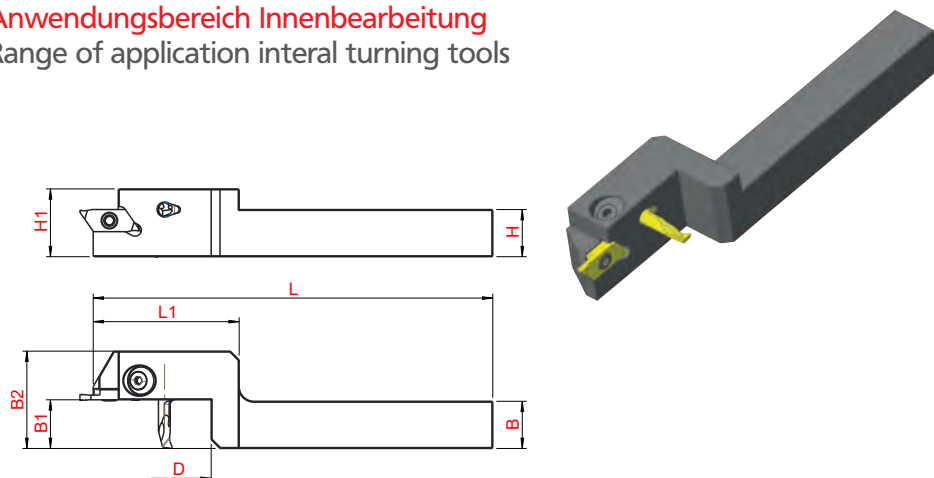

**Außen- / Innendrehhalter Typ HORN Typ 105 und S 274**  
External- / Internal turning holder type HORN type 105 and S 274

**Anwendungsbereich Innenbearbeitung**  
Range of application internal turning tools



Bestell Nummer Order Number	Bezeichnung Description	L	B	H	H1	B1	B2	L1	D	für Wendeplatte for insert
14-0987	AIH.974.R.1212.K04	130	12	12	19	16,5	33	50	30	Horn Typ 105 und S 274
14-0986	AIH.974.R.1616.K04	130	16	16	23	16,5	33	50	30	
14-0367	AIH.974.R.2020.K04	130	20	20	27	16,5	33	55	32	

Abmessungen in mm  
Dimensions in mm

Ersatzteile / Spare parts	
	
4.123	001.01.39

Weitere Größen auf Anfrage  
other sizes on request

**Wendeplattenhalter HORN Typ S 100**  
Turret plate holder HORN type S 100

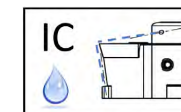

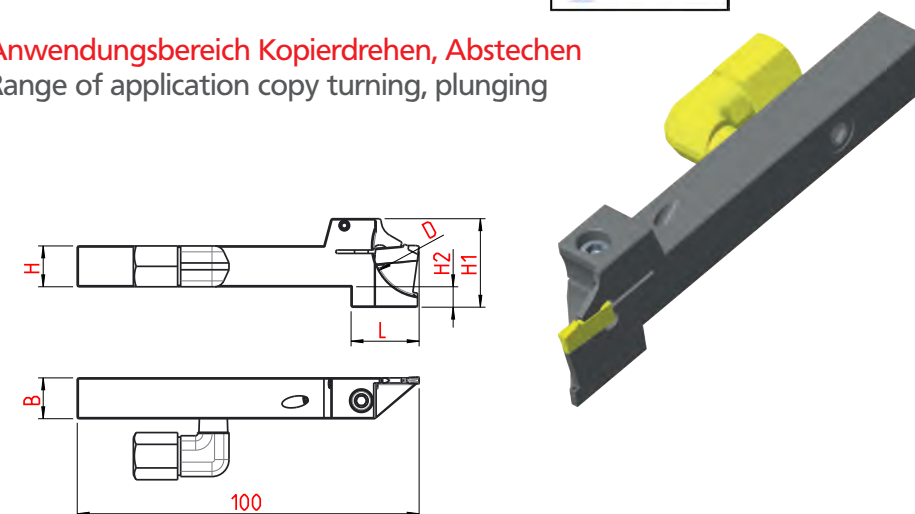

**Anwendungsbereich Kopierdrehen, Abstechen**  
Range of application copy turning, plunging



Bestell Nummer Order Number	Bezeichnung Description	H	B	H1	H2	L	D <sub>max</sub>	für Wendeplatte for insert
01-1341	910.R.1012.01.2IK	10	12	24	6	20	20	HORN Typ S 100 Größe 01
01-1342	910.L.1012.01.2IK	10	12	24	6	20	20	
01-1339	910.R.1212.01.2IK	12	12	26	6	20	26	
01-1340	910.L.1212.01.2IK	12	12	26	6	20	26	
01-1343	910.R.1616.01.2IK	16	16	34	10	25	42	
01-1344	910.L.1616.01.2IK	16	16	34	10	25	42	

Abmessungen in mm  
Dimensions in mm

für Stechbreite 2,0 - 2,2 mm  
width of groove 2,0 - 2,2 mm

Ersatzteile / Spare parts	
	
004.00.22	001.01.64

Weitere Größen auf Anfrage  
other sizes on request

**Wendepplattenhalter HORN Typ S 100**  
Turret plate holder HORN type S 100

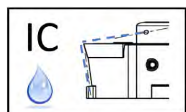

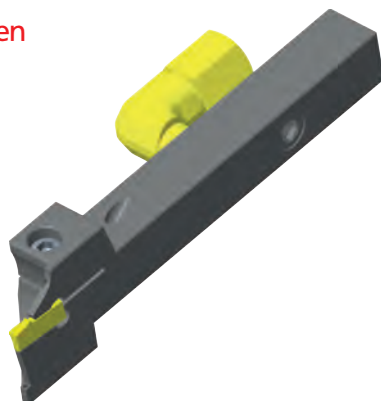
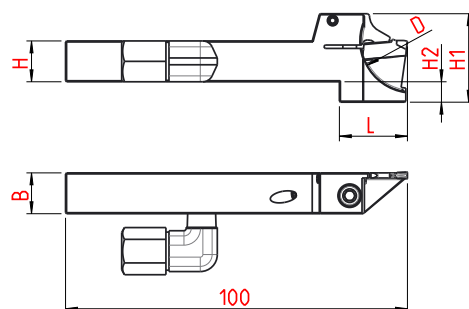

**Anwendungsbereich Kopierdrehen, Abstechen**  
Range of application copy turning, plunging



Bestell Nummer Order Number	Bezeichnung Description	H	B	H1	H2	L	D <sub>max</sub>	für Wendepplatte for insert
01-1354	910.R.1012.02.2IK	10	12	24	6	20	20	HORN Typ S 100 Größe 02
01-1356	910.L.1012.02.2IK	10	12	24	6	20	20	
01-1352	910.R.1212.02.2IK	12	12	26	6	20	26	
01-1353	910.L.1212.02.2IK	12	12	26	6	20	26	
01-1355	910.R.1616.02.2IK	16	16	34	10	25	42	
01-1357	910.L.1616.02.2IK	16	16	34	10	25	42	

Abmessungen in mm  
Dimensions in mm

für Stechbreite 2,5 mm  
width of groove 2,5 mm

Ersatzteile / Spare parts	
	
004.00.22	001.01.64

Weitere Größen auf Anfrage  
other sizes on request

**Wendepplattenhalter HORN Typ S 100**  
Turret plate holder HORN type S 100



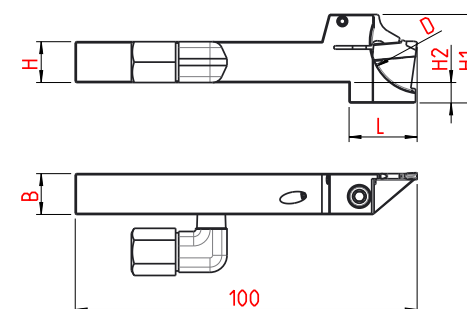

**Anwendungsbereich Kopierdrehen, Abstechen**  
Range of application copy turning, plunging



Bestell Nummer Order Number	Bezeichnung Description	H	B	H1	H2	L	D <sub>max</sub>	für Wendepplatte for insert
01-1358	910.R.1212.03.2IK	12	12	26	6	20	26	HORN Typ S 100 Größe 03
01-1359	910.L.1212.03.2IK	12	12	26	6	20	26	
01-1362	910.R.1616.03.2IK	16	16	34	10	25	42	
01-1363	910.L.1616.03.2IK	16	16	34	10	25	42	

Abmessungen in mm  
Dimensions in mm

für Stechbreite 3,0 mm  
width of groove 3,0 mm

Ersatzteile / Spare parts	
	
004.00.22	001.01.64

Weitere Größen auf Anfrage  
other sizes on request