

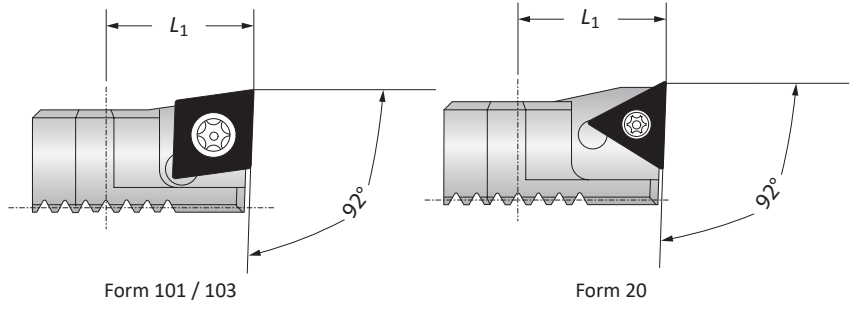

Insert Holders for Abrasive Materials

Diameter Range: 65.00 mm - 205.00 mm

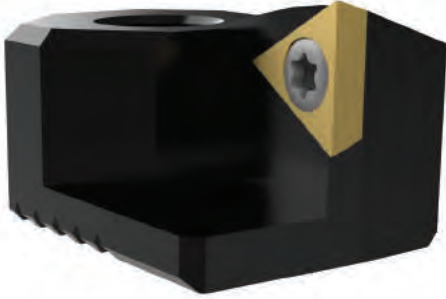

	Insert Holder				
	L_1	Weight	Insert Form	Part No.	
	65.00 - 205.00	18.00	0.03 (kg)	20	211061
	65.00 - 205.00	18.00	0.03 (kg)	101	211063
	65.00 - 205.00	18.00	0.03 (kg)	103	211065

NOTE: Insert holders used for abrasive materials to protect boring head against chip wash

NOTE: When machining grey cast iron, we recommend using insert holders for abrasive materials with CBN inserts for optimised chip removal.

Key on B10-B: 1

B10-M: 12-13

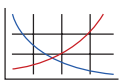

B10-H

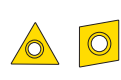

B10: VI-VII



 = Metric (mm)
Inserts sold separately