

Werkzeugaufnahmen PSC

Tool holders PSC

Seite
Page

Fräsaufnahmen für Einschraubfräser
Modular screw on holder

102

Fräsdorne
Arbors for shell cutters

103

Weldonfutter
Side lock adapter

104

Spannzangenfutter
Collet chucks

105

CNC-Bohrfutter
CNC-drill chucks

106

Andere Ausführungen und Längen auf Anfrage lieferbar.
Specials on request.

Fräsaufnahme PSC-63 für Einschraubfräser

shank PSC-63 for threaded type cutter

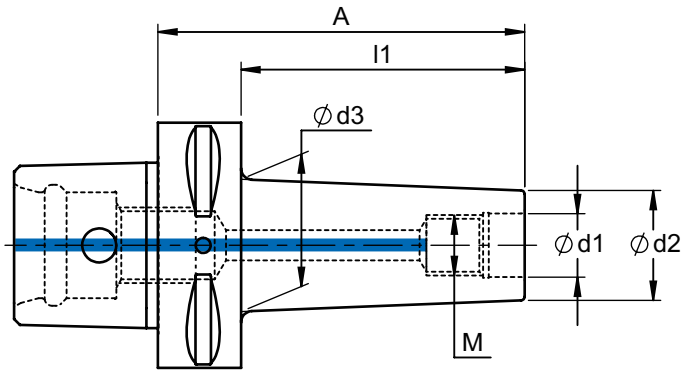

Bestell-Nr. order number	M	d1	d2	d3	A	l1	
920-PSC631050	M10	10,5	18	25	72	50	G2,5/15.000
920-PSC631050zy	M10	10,5	18	18	72	50	
920-PSC631075	M10	10,5	18	30	97	75	
920-PSC631075zy	M10	10,5	18	18	97	75	
920-PSC6310100	M10	10,5	18	35	122	100	
920-PSC631250	M12	12,5	21	30	72	50	
920-PSC631250zy	M12	12,5	23	23	72	50	
920-PSC631275	M12	12,5	21	35	97	75	
920-PSC631275zy	M12	12,5	23	23	97	75	
920-PSC6312100	M12	12,5	21	38	122	100	
920-PSC631650	M16	17	29	34	72	50	
920-PSC631650zy	M16	17	29	29	72	50	
920-PSC631675	M16	17	29	35	97	75	
920-PSC631675zy	M16	17	29	29	97	75	
920-PSC6316100	M16	17	29	40	122	100	

Fräsdorne PSC-63

arbors PSC-63 for shell cutter

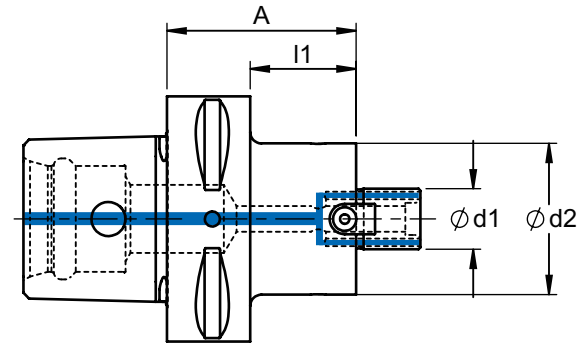



Bestell-Nr. order number	d1	d2	l1	A						
922-PSC6316A50	16	40	28	50	959-16	-	957-M8	-	G6,3/8.000	
922-PSC6316A100	16	40	78	100	959-16	-	957-M8	-		
922-PSC6322A50	22	50	28	50	959-22	-	957-M10	-		
922-PSC6322A100	22	50	78	100	959-22	-	957-M10	-		
922-PSC6327A50	27	60	28	50	959-27	-	957-M12	-		
922-PSC6327A100	27	60	78	100	959-27	-	957-M12	-		
922-PSC6332A60	32	63	38	60	959-32	957-32	-	958-32		

Weldonfutter PSC-63

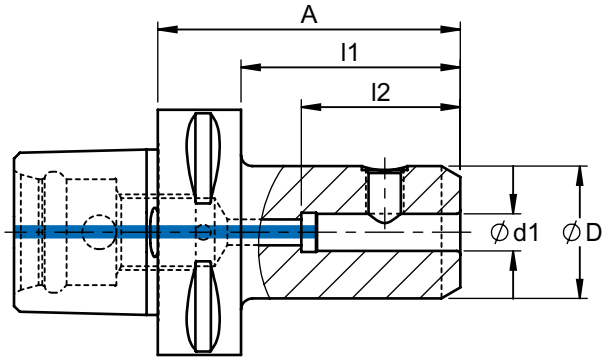
weldon chuck HSK-F63





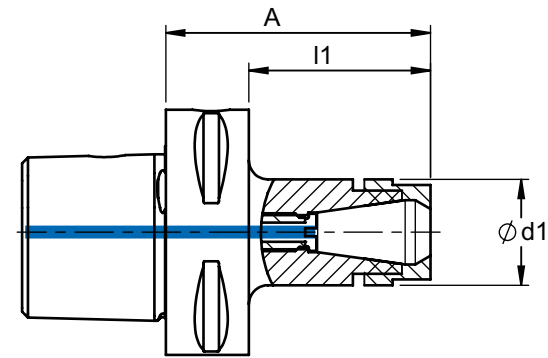

Bestell-Nr. order number	d1	D	l1	A		
903-PSC6306A75	6	25	53	75	949-M6	G6,3/8.000
903-PSC6306A120	6	25	98	120	949-M6	
903-PSC6308A80	8	28	58	80	949-M8	
903-PSC6308A120	8	28	98	120	949-M8	
903-PSC6310A80	10	35	58	80	949-M10	
903-PSC6310A120	10	35	98	120	949-M10	
903-PSC6312A80	12	42	58	80	949-M12	
903-PSC6312A120	12	42	98	120	949-M12	
903-PSC6314A80	14	44	58	80	949-M12	
903-PSC6316A80	16	48	58	80	949-M14	
903-PSC6316A120	16	48	98	120	949-M14	
903-PSC6318A80	18	50	58	80	949-M14	
903-PSC6320A85	20	52	63	85	949-M16	
903-PSC6320A120	20	52	98	120	949-M16	
903-PSC6325A90	25	65	68	90	949-M18x2	
903-PSC6332A90	32	72	68	90	949-M20x2	
903-PSC6340A100	40	80	78	100	949-M20x2	

ER-Spannzangenfutter PSC-63

collet chucks for collets ER PSC-63



Bestell-Nr. order number	d1	l1	A					
910-PSC63A70	28	48	70	953-UM16	-	954-013ER16	G6,3/8.000	
910-PSC63A100	28	78	100	953-UM16	948-M10	954-013ER16		
912-PSC63A70	42	48	70	953-UM25	-	954-013ER25		
912-PSC63A110	42	88	110	953-UM25	948-M12	954-013ER25		
913-PSC63A70	50	48	70	953-UM32	-	954-013ER32		
913-PSC63A110	50	88	110	953-UM32	948-M16	954-013ER32		
914-PSC63A80	63	58	80	953-UM40	-	954-013ER40		

CNC- Bohrfutter PSC40 - 80 für Rechts- und Linkslauf

CNC- drill chucks PSC40 - 80 for clockwise and anti clockwise rotation

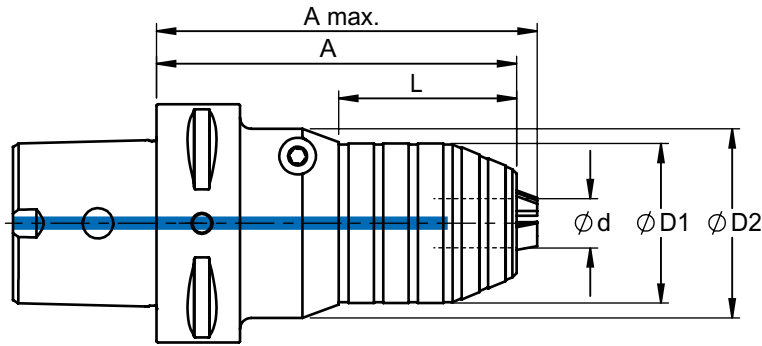

Bestell-Nr. order number	PSC	d	D1	D2	L	A	A max.		
407-PSC4008A80	40	0,5 - 8	34,5	45,0	40,0	80,0	82,5	G6,3/8.000	
407-PSC5008A80	50	0,5 - 8	34,5	45,0	40,0	80,0	82,5		
407-PSC5013A90	50	1 - 13	42,0	50,0	47,0	90,0	99,0		
407-PSC5016A90	50	2,5 - 16	49,0	50,0	50,0	90,0	101,0		
407-PSC6308A85	63	0,5 - 8	34,5	45,0	40,0	85,0	87,5		
407-PSC6313A95	63	1 - 13	42,0	50,0	47,0	95,0	104,0		
407-PSC6316A95	63	2,5 - 16	49,0	50,0	50,0	95,0	106,0		
407-PSC8013A100	80	1 - 13	42,0	50,0	47,0	100,0	109,0		
407-PSC8016A100	80	2,5 - 16	49,0	50,0	50,0	100,0	111,0		

Werkzeugaufnahmen SK

Tool holders SK

Seite
Page

Fräsaufnahmen für Einschraubfräser
Modular screw on holder

109 - 117

Fräsdorne
Arbors for shell cutters

118 - 121

Fräserhülsen / Zwischenhülsen
Morse taper adaptors

122 - 123

Weldonfutter
Side lock adapter

125

Spannzangenfutter
Collet chucks

126 - 127

CNC-Bohrfutter
CNC-drill chucks

129

Plananlagen für Einschraub- und Aufsteckfräser
Arbors with face contact for modular screw in cutter and shell cutters

130 - 131

Rohlinge
Blanks

132

Andere Ausführungen und Längen auf Anfrage lieferbar.
Specials on request.