

M620



**Corps de fraise avec
plaquette interchangeable**

Diamètre de coupe 21,7 mm

**Corpo fresa a inserti
intercambiabili**

Diametro 21,7 mm

Corps de fraise

Corpo fresa

M620



B

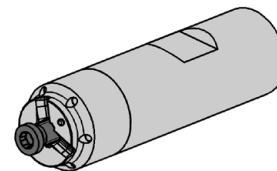
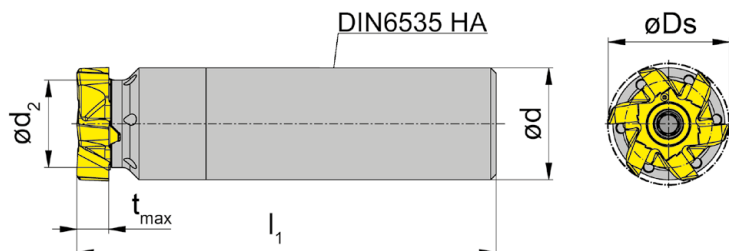
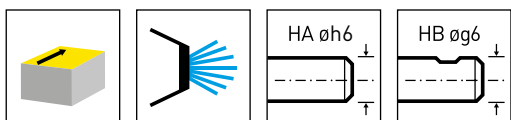

N° de commande Codice prodotto	Ds	d	l ₁	d ₂	Forme Forma	HWS
M620.0020.D.00A	21,7	20	75	15,6	A	620156R
M620.0020.D.00B	21,7	20	75	15,6	B	620156R
M620.0020.D.04A	21,7	20	130	15,6	A	620156R
M620.0020.D.04B	21,7	20	130	15,6	B	620156R

tmax voir plaquettes
tmax vd. inserti

Pièces Détachées

Ricambi

Corps de fraise Corpo fresa	Vis de serrage Vite di serraggio	Tournevis TORX PLUS® Cacciavite TORX PLUS®
M620...	5.14T20P	T20PQ

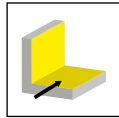
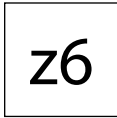
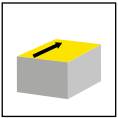

B

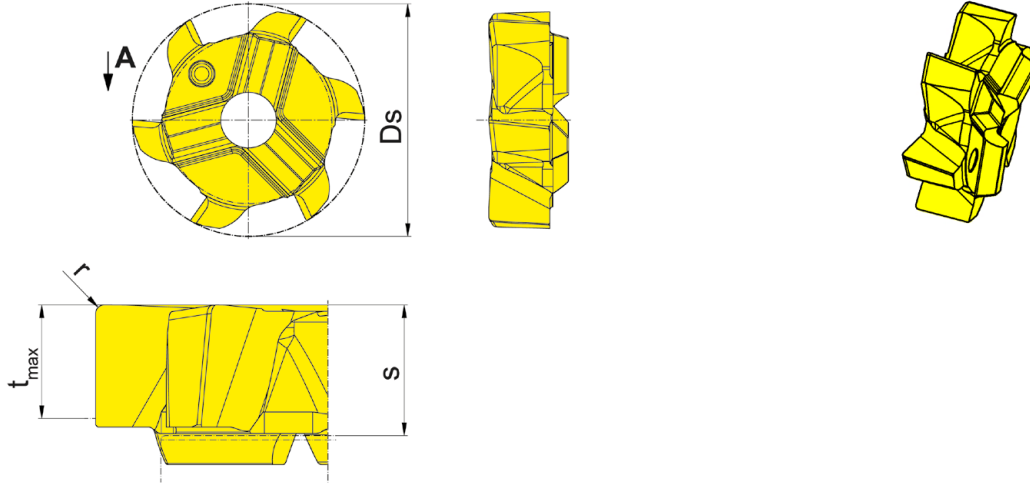

Nuance
Leghe

▲ en stock
a stock

Δ 4 semaines
4 settimane

N° de commande Codice prodotto	Ds	Z	r	t _{max}	s	HIS	AS45
620.PL53.64	21,7	6	0,4	5,3	6,1	620156R	▲
							P ●
							M ●
							K ●
							N ○
							S ●
							H -

B

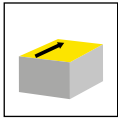

z6

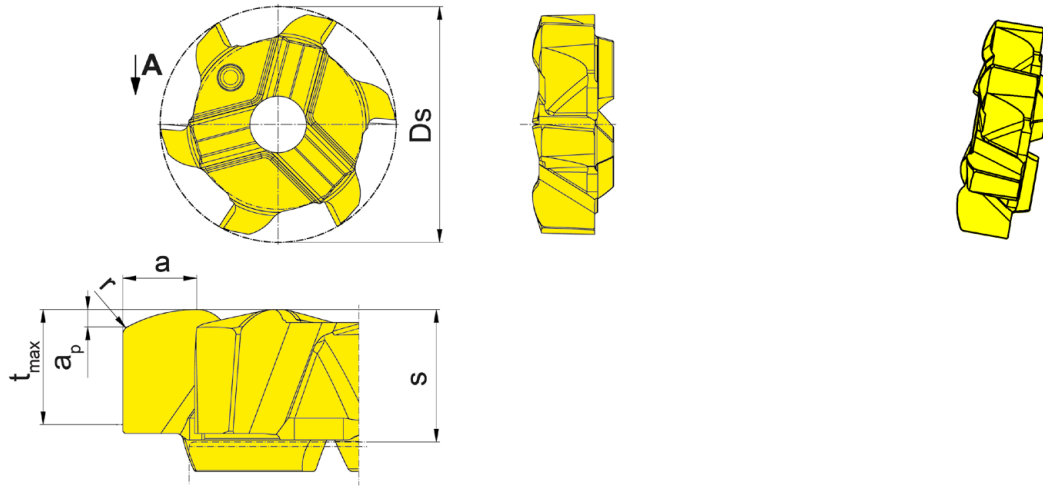

Nuance
Leghe

▲ en stock
a stock

Δ 4 semaines
4 settimane

N° de commande Codice prodotto	D _s	a	Z	r	t _{max}	a _p	s	HIS	AS45
620.HV08.04	21,7	4,4	6	0,4	5,3	0,8	6,1	620156R	▲
									P ●
									M ●
									K ●
									N ○
									S ●
									H -

Fraisage grande avance
Fresatura ad alta velocità

Angle de plongée Angolo di rampa	Le rayon théorique r _{th} = le rayon de programmation Raggio teorico = raggio per la programmazione	Différence Max (mm) sovrametallo max. (mm)
1°	1,15 mm	0,43 mm