

M101



E

Fraise de gorges

de Diamètre de coupe 63 mm
Largeur de gorge 1,2 - 4,6 mm

Frese per gole

da Diametro 63 mm
Larghezza della gola
1,2 - 4,6 mm

Fraise de gorges
Frese per gole
M101

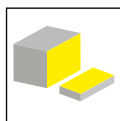

Page/Pag.
235

Fraise disque
Frese a disco
M101

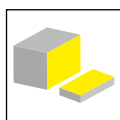

Page/Pag.
236-237

Fraise à moyeu
Fresa a manicotto
M101

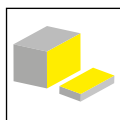

Page/Pag.
238-239

Plaquette
Inserto
S101

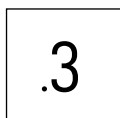

Page/Pag.
240, 243

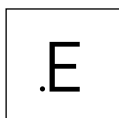

Page/Pag.
241-242

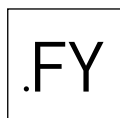

Page/Pag.
244

Informations techniques
Informazioni tecniche

Page/Pag.
245

E

Fraise de gorges

Frese per gole

M101

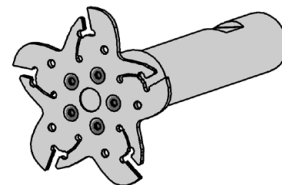
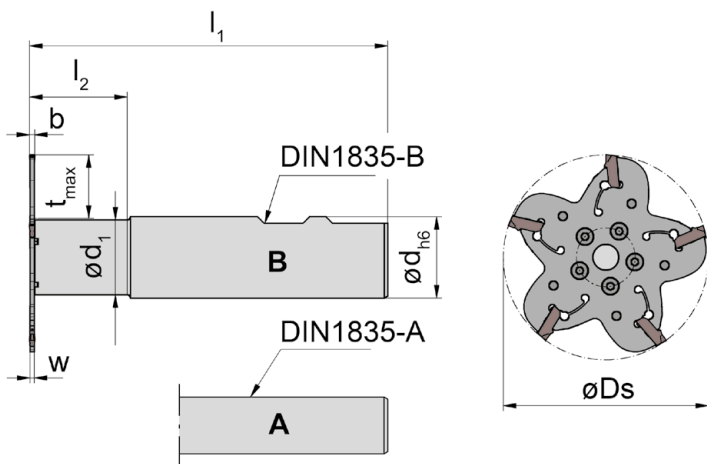
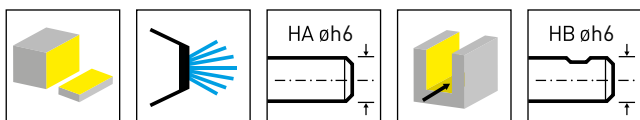

E

Illustration de coupe à droite représentée
Figura = taglio destro

N° de commande Codice prodotto	Z	Ds	d	l ₁	l ₂	d ₁	b	t _{max}	Forme Forma	Largueur de gorge Larghezza della gola	n _{max}	HWS
M101.063.D16.23.2.12A	5	63	16	110	30	23	0,95	19,5	A	1,2-1,2	7500	10112
M101.063.D16.23.2.14A	5	63	16	110	30	23	1,15	19,5	A	1,4-1,4	7500	10114
M101.063.D16.23.2.16A	5	63	16	110	30	23	1,3	19,5	A	1,6-1,8	7500	10116
M101.063.D16.23.2.20A	5	63	16	110,35	30,4	23	1,6	19,5	A	2,0-2,3	7500	10120
M101.063.D20.23.2.12B	5	63	20	110	30	23	0,95	19,5	B	1,2-1,2	7500	10112
M101.063.D20.23.2.14B	5	63	20	110	30	23	1,15	19,5	B	1,4-1,4	7500	10114
M101.063.D20.23.2.16B	5	63	20	110	30	23	1,3	19,5	B	1,6-1,8	7500	10116
M101.063.D20.23.2.20B	5	63	20	110,35	30,4	23	1,6	19,5	B	2,0-2,3	7500	10120
M101.063.D25.23.2.12B	5	63	25	110	30	23	0,95	19,5	B	1,2-1,2	7500	10112
M101.063.D25.23.2.16B	5	63	25	110	30	23	1,3	19,5	B	1,6-1,8	7500	10116
M101.063.D25.23.2.20B	5	63	25	110	30	23	1,6	19,5	B	2,0-2,3	7500	10120

La clé P101.01 n'est pas fournie avec le fraise - à cder séparément!
La chiave P101.01 non viene fornita con fresa - bisogna ordinarla separatamente!

Pièces Détachées

Ricambi

Fraise de gorges Frese per gole	Queue Attacco	Lame Lama	Tournevis TORX PLUS® Cacciavite TORX PLUS®	Vis de serrage Vite di serraggio
M101.063.D16.23.2.12A	020.D16.23.2.12 A	M101.0063.28.23.12	T8PL	
M101.063.D16.23.2.14A	020.D16.23.2.12 A	M101.0063.28.23.14	T8PL	
M101.063.D16.23.2.16A	020.D16.23.2.16A	M101.0063.28.23.16	T8PL	
M101.063.D16.23.2.20A	020.D16.23.2.16A	M101.0063.28.23.20	T8PL	
M101.063.D20.23.2.12B	020.D20.23.2.12B	M101.0063.28.23.12	T8PL	
M101.063.D20.23.2.14B	020.D20.23.2.12B	M101.0063.28.23.14	T8PL	
M101.063.D20.23.2.16B	020.D20.23.2.16B	M101.0063.28.23.16	T8PL	
M101.063.D20.23.2.20B	020.D20.23.2.16B	M101.0063.28.23.20	T8PL	
M101.063.D25.23.2.12B	020.D25.23.2.12B	M101.0063.28.23.12	T8PL	030.3543.T8P
M101.063.D25.23.2.16B	020.D25.23.2.16B	M101.0063.28.23.16	T8PL	030.3543.T8P
M101.063.D25.23.2.20B	020.D25.23.2.20B	M101.0063.28.23.20	T8PL	030.3543.T8P

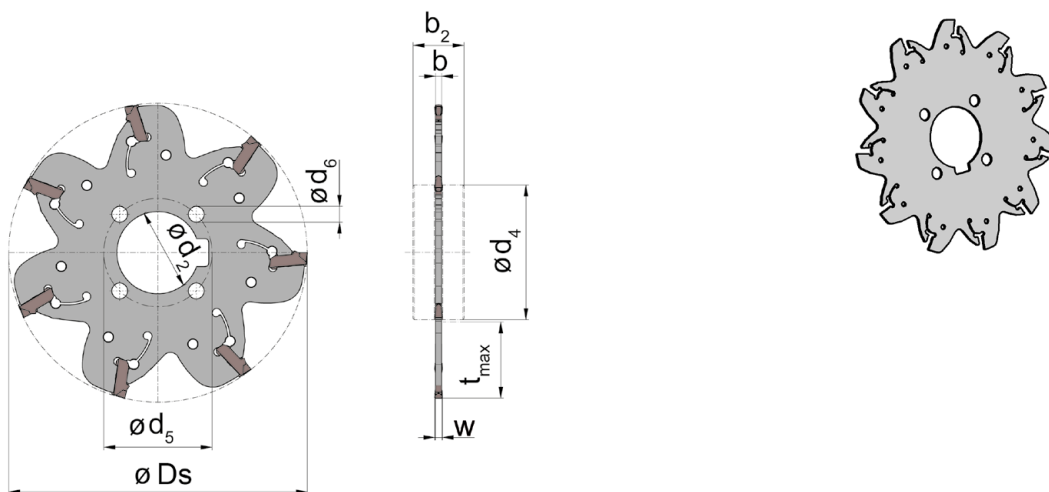
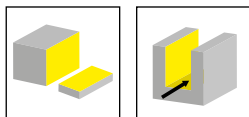

Illustration de coupe à droite représentée
Figura = taglio destro

N° de commande Codice prodotto	Z	Ds	t _{max}	b	d ₂	b ₂	d ₄	d ₆	d ₅	Largueur de gorge Larghezza della gola	n _{max}	HWS
M101.0080.22.12	7	80	20	0,95	22	13	36	4,25	29	1,2-1,2	6000	10112
M101.0080.22.14	7	80	20	1,15	22	13,1	36	4,25	29	1,4-1,4	6000	10114
M101.0080.22.16	7	80	20	1,3	22	13,3	36	4,25	29	1,6-1,8	6000	10116
M101.0100.22.16	9	100	30	1,3	22	13,3	36	4,25	29	1,6-1,8	5000	10116
M101.0125.32.16	11	125	33	1,3	32	21,3	55	6,25	45	1,6-1,8	4000	10116
M101.0080.22.20	7	80	20	1,6	22	13,6	36	4,25	29	2,0-2,3	6000	10120
M101.0100.22.20	9	100	30	1,6	22	13,6	36	4,25	29	2,0-2,3	5000	10120
M101.0125.32.20	11	125	33	1,6	32	21,6	55	6,25	45	2,0-2,3	4000	10120

La clé **P101.01** et les **bagues d'entraînement** ne sont pas fournies avec le fraise. À commander séparément.
La chiave P101.01 e gli anelli per il bloccaggio non sono compresi - ordinare separatamente!

Pièces Détachées

Ricambi

Fraise disque Frese a disco	Bagues d'entraînement Anelli per il bloccaggio
M101....	020.22.06.36
M101.0125.32...	020.32.10.55

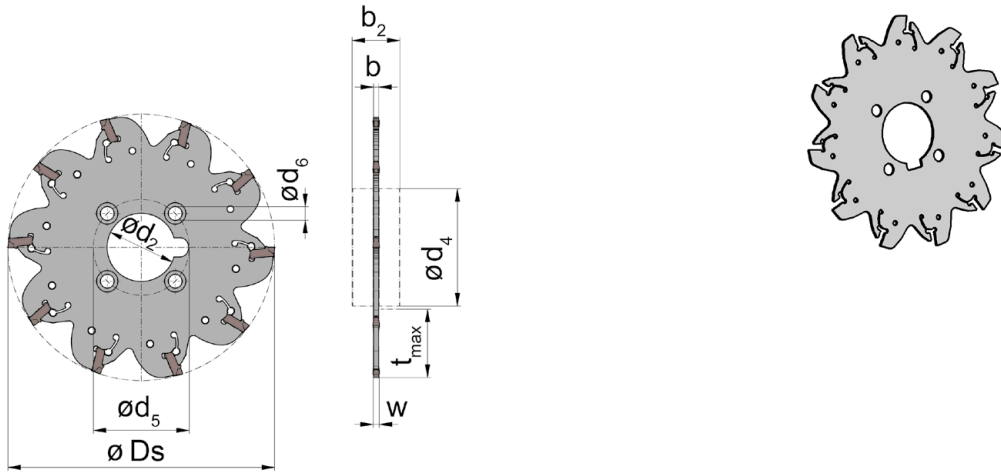
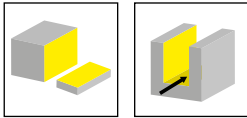

Illustration de coupe à droite représentée
Figura = taglio destro

N° de commande Codice prodotto	Z	Ds	t _{max}	b	d ₂	b ₂	d ₄	d ₆	d ₅	Largueur de gorge Larghezza della gola	n _{max}	HWS
M101.0080.22.30	6	80	20	2,4	22	14,4	36	4,25	29	2,8-3,4	6000	10130
M101.0100.22.30	8	100	26	2,4	22	22,4	46	5,25	32	2,8-3,4	5000	10130
M101.0125.32.30	10	125	34	2,4	32	22,4	55	6,25	45	2,8-3,4	4000	10130
M101.0160.40.30	12	160	39	2,4	40	26,4	80	11,25	63	2,8-3,4	3000	10130
M101.0080.22.40	6	80	20	3,2	22	15,2	36	4,25	29	3,8-4,6	6000	10140
M101.0100.22.40	8	100	26	3,2	22	23,2	46	5,25	32	3,8-4,6	5000	10140
M101.0125.32.40	10	125	34	3,2	32	23,2	55	6,25	45	3,8-4,6	4000	10140
M101.0160.40.40	12	160	39	3,2	40	27,2	80	11,25	63	3,8-4,6	3000	10140
M101.0200.40.40	16	200	59	3,2	40	27,2	80	11,25	63	3,8-4,6	2500	10140

La clé **P101.02** et les **bagues d'entraînement** ne sont pas fournies avec le fraise. À commander séparément.
La chiave P101.02 e gli anelli per il bloccaggio non sono compresi - ordinare separatamente!

Pièces Détachées

Ricambi

Fraise disque Frese a disco	Bagues d'entraînement Anelli per il bloccaggio
M101....	020.22.06.36
M101.0125.32...	020.32.10.55

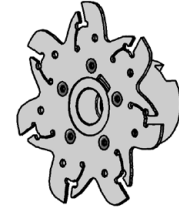
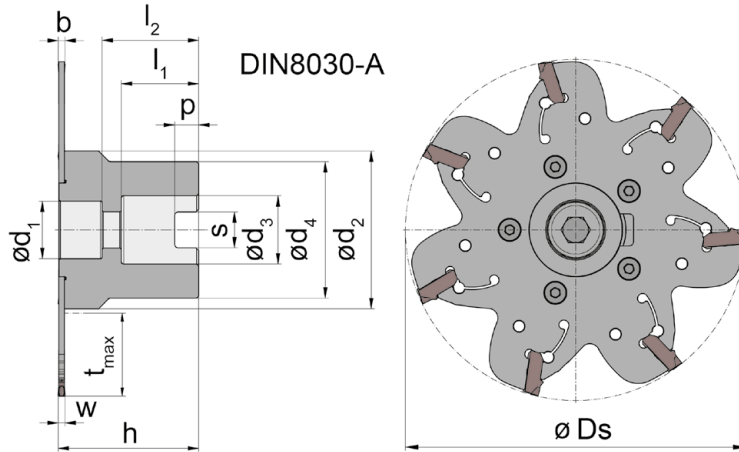
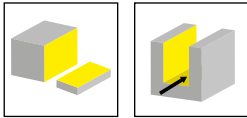

Illustration de coupe à droite représentée
Figura = taglio destro

N° de commande Codice prodotto	Z	Ds	t _{max}	h	b	d ₁	d ₄	l ₁	l ₂	s	P	d ₂	d ₃	n _{max}	Largueur de gorge Larghezza della gola	HWS
M101.0080.A16.12	7	80	20	33	0,95	13,5	32	18	22,7	8,4	5,6	37	16	6000	1,2-1,2	10112
M101.0080.A16.14	7	80	20	33,2	1,15	13,5	32	18	22,7	8,4	5,6	37	16	6000	1,4-1,4	10114
M101.0080.A16.16	7	80	20	33	1,3	13,5	32	18	22,7	8,4	5,6	37	16	6000	1,6-1,8	10116
M101.0100.A22.16	9	100	28	37	1,3	18,5	40,5	20	24,7	10,4	6,3	40,5	22	5000	1,6-1,8	10116
M101.0125.A32.16	11	125	34	50	1,3	28,5	45	25	36,7	14,4	8	55	32	4000	1,6-1,8	10116
M101.0080.A16.20	7	80	20	33	1,6	13,5	32	18	22,7	8,4	5,6	37	16	6000	2,0-2,3	10120
M101.0100.A22.20	9	100	28	37	1,6	18,5	40,5	20	24,7	10,4	6,3	40,5	22	5000	2,0-2,3	10120
M101.0125.A32.20	11	125	34	50	1,6	28,5	45	25	36,7	14,4	8	55	32	4000	2,0-2,3	10120

La clé **P101.01** n'est pas fournie avec le fraise - à cder séparément!
La chiave P101.01 non viene fornita con fresa - bisogna ordinarla separatamente!

Pièces Détachées

Ricambi

Fraise à moyeu Fresa a manicotto	Vis de serrage Vite di serraggio	Lame Lama	Tournevis TORX PLUS® Cacciavite TORX PLUS®
M101.0080.A16.12	030.3543.T8P	M101.0080.28.12	T8PL
M101.0080.A16.14	030.3543.T8P	M101.0080.28.14	T8PL
M101.0080.A16.16	030.3543.T8P	M101.0080.28.16	T8PL
M101.0100.A22.16	030.3543.T8P	M101.0100.28.16	T8PL
M101.0125.A32.16	030.3543.T8P	M101.0125.28.16	T8PL
M101.0080.A16.20	030.3543.T8P	M101.0080.28.20	T8PL
M101.0100.A22.20	030.3543.T8P	M101.0100.28.20	T8PL
M101.0125.A32.20	030.3543.T8P	M101.0125.28.20	T8PL

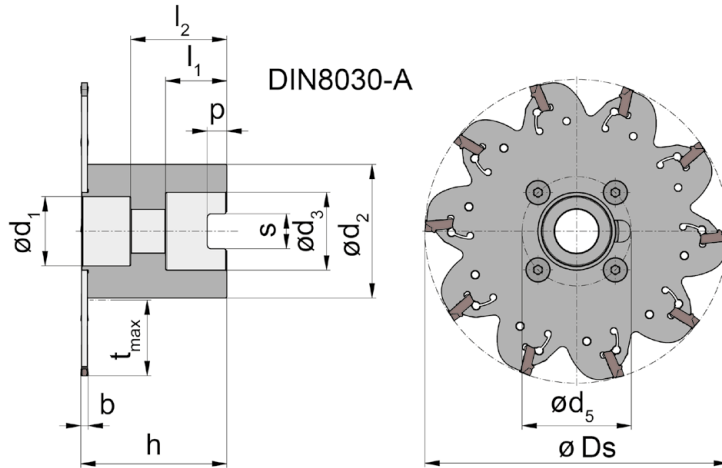
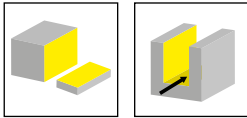

Illustration de coupe à droite représentée
Figura = taglio destro

N° de commande Codice prodotto	Z	Ds	t _{max}	h	b	d ₁	l ₁	l ₂	s	P	d ₂	d ₃	n _{max}	Largeur de gorge Larghezza della gola	HWS
M101.0080.A22.30	6	80	19	37	2,4	18,5	20	24,7	10,4	6,3	22	22	5000	2,8-3,4	10130
M101.0100.A22.30	8	100	29	37	2,4	18,5	20	24,7	10,4	6,3	40	22	5000	2,8-3,4	10130
M101.0125.A32.30	10	125	34	50	2,4	28,5	25	36,7	14,4	8	55	32	4000	2,8-3,4	10130
M101.0160.A40.30	12	160	39	50	2,4	34,5	28	35	16,4	9	80	40	3000	2,8-3,4	10130
M101.0080.A22.40	6	80	19	37,9	3,2	18,5	20	24,7	10,4	6,3	22	22	5000	3,8-4,6	10140
M101.0100.A22.40	8	100	29	37,9	3,2	18,5	20	24,7	10,4	6,3	40	22	5000	3,8-4,6	10140
M101.0125.A32.40	10	125	34	50,9	3,2	28,5	25	36,7	14,4	8	55	32	4000	3,8-4,6	10140
M101.0160.A40.40	12	160	39	50,9	3,2	34,5	28	35	16,4	9	80	40	3000	3,8-4,6	10140
M101.0200.A40.40	16	200	59	50,9	3,2	34,5	28	35	16,4	9	80	40	2500	3,8-4,6	10140

La clé P101.02 n'est pas fournie avec le fraise - à cder séparément!
La chiave P101.02 non viene fornita con fresa - bisogna ordinarla separatamente!

Pièces Détachées

Ricambi

Fraise à moyeu Fresa a manicotto	Vis de serrage Vite di serraggio	Lame Lama	Tournevis TORX PLUS® Cacciavite TORX PLUS®
M101.0080.A22.30	030.3543.T8P	M101.0080.28.30	T15PQ
M101.0100.A22...	030.3543.T8P		T15PQ
M101.0125.A32...	030.3543.T8P		T20PQ
M101....	030.3543.T8P		
M101.0080.A22.40		M101.0080.28.40	T15PQ

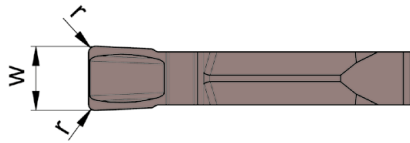
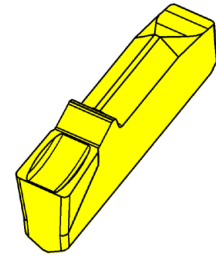
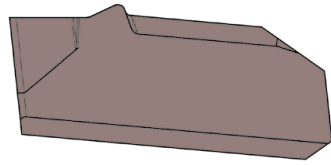
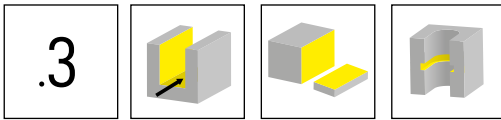

E

Nuance
Leghe

▲ en stock
a stock

Δ 4 semaines
4 settimane

N° de commande Codice prodotto	w	r	HIS	Nuance	
				AS45	IG35
S101.0120.315	1,2	0,15	10112	▲	▲
S101.0140.315	1,4	0,15	10114	▲	▲
S101.0160.315	1,6	0,15	10116	▲	▲
S101.0200.320	2	0,2	10120	▲	▲
S101.0250.320	2,5	0,2	10120	Δ	Δ
				P	-
				M	•
				K	-
				N	o
				S	•
				H	-

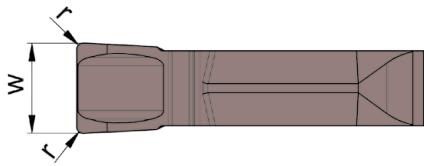
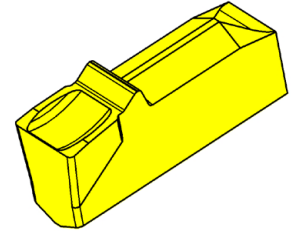
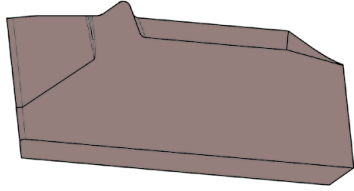
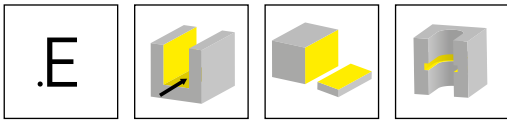

Nuance
Leghe

▲ en stock
a stock

Δ 4 semaines
4 settimane

N° de commande Codice prodotto	w	r	HIS	AS45
S101.0300.E32	3	0,2	10130	▲
S101.0400.E33	4	0,3	10140	▲
				P ●
				M ●
				K ●
				N ○
				S ●
				H -



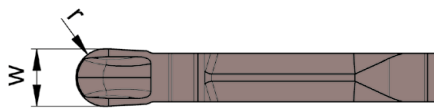
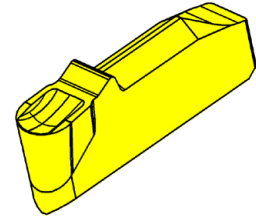
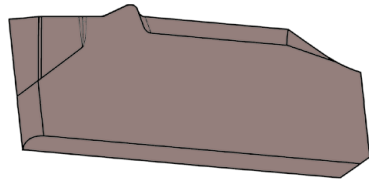
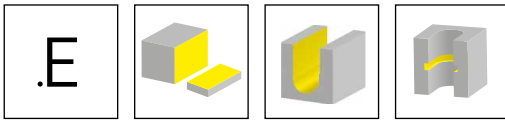

E

Nuance
Leghe

▲ en stock
a stock

Δ 4 semaines
4 settimane

N° de commande Codice prodotto	w	r	HIS	AS45
S101.0160.E3.R08	1,6	0,8	10116	▲
S101.0200.E3.R10	2	1	10120	▲
S101.0300.E3.R15	3	1,5	10130	▲
				P ●
				M ●
				K ●
				N o
				S ●
				H -

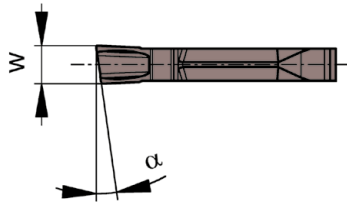
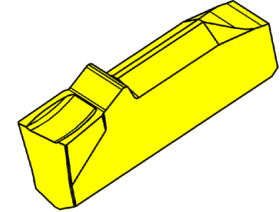
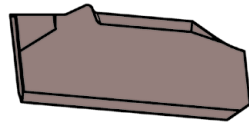
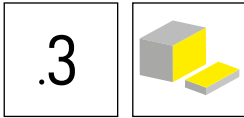

R = version à droite représentée
R = versione destra come in figura

L = version à gauche
L = versione sinistra a specchio

▲ en stock
a stock

Nuance
Leghe
Δ 4 semaines
4 settimane

N° de commande Codice prodotto	w	α	HIS	Nuance / Leghe		
				AS45	EG55	IG35
RS101.0812.30	1,2	8°	10112		▲	▲
RS101.0816.30	1,6	8°	10116	▲		▲
RS101.0820.30	2	8°	10120	▲		▲
RS101.0825.30	2,5	8°	10120	▲		▲
LS101.0812.30	1,2	8°	10112		▲	▲
LS101.0816.30	1,6	8°	10116	▲		▲
LS101.0820.30	2	8°	10120	▲		▲
LS101.0825.30	2,5	8°	10120	▲		▲
P	●	●	-			
M	●	○	●			
K	●	○	-			
N	○	-	-			
S	●	-	●			
H	-	-	-			



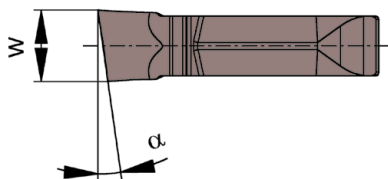
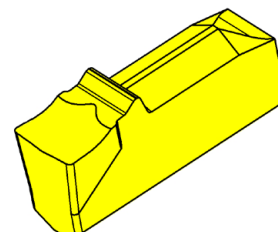
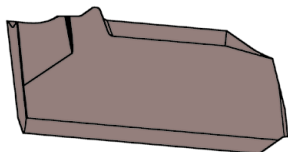
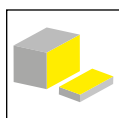
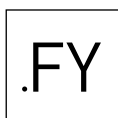

E

R = version à droite représentée
R = versione destra come in figura

L = version à gauche
L = versione sinistra a specchio

▲ en stock
a stock

Nuance
Leghe
Δ 4 semaines
4 settimane

N° de commande Codice prodotto	w	α	HIS	AS45	IG35
RS101.0830.FY0	3	8°	10130	▲	▲
LS101.0830.FY0	3	8°	10130	▲	▲
				P ● -	
				M ● ●	
				K ● -	
				N ○ -	
				S ● ●	
				H - -	

Position de la clé de clampage P101.01

Posizionamento della chiave di serraggio P101.01

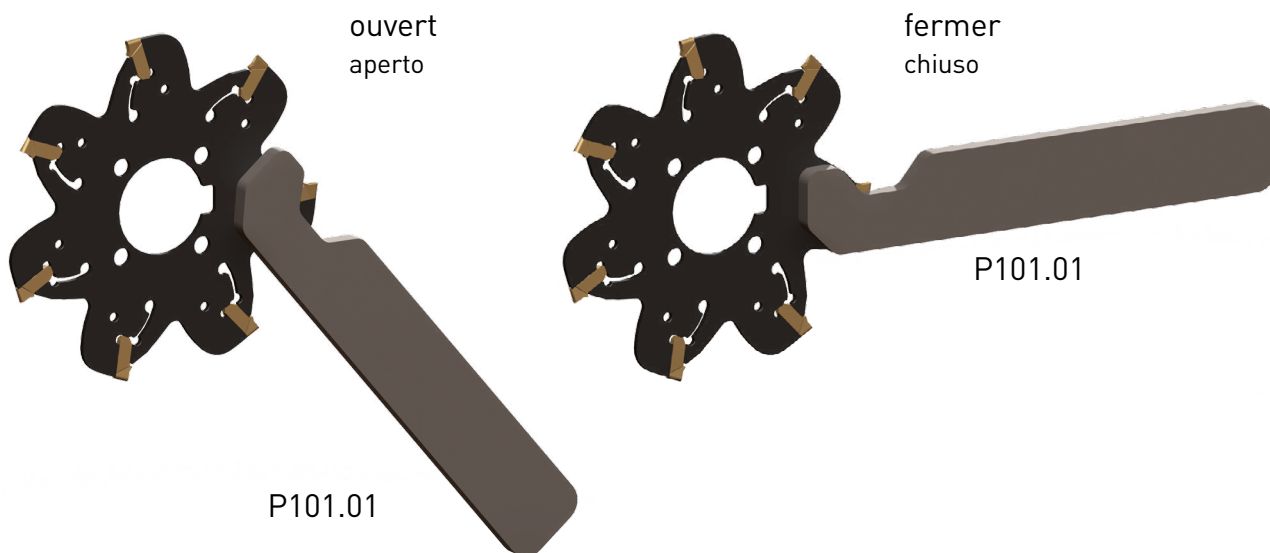

Si possible, ne fraiser qu'en opposition pour éviter le coincement des copeaux.
Après le changement de plaquettes, réduisez la vitesse d'avance de 50 % jusqu'à ce qu'une profondeur de coupe initiale de 0,5 à 1 mm soit atteinte.

Utilizzare solo la fresatura convenzionale per evitare l'intasamento dei trucioli.
Dopo ogni cambio inserti, ridurre l'avanzamento del 50% fino al raggiungimento della profondità di taglio iniziale di 0,5 - 1 mm.

Merci de faire attention à la rotation maximum de la fraise.
Fare attenzione al massimo numero di giri!

Ø Fraises disques Ø Frese a disco	max. Vitesse de rotation n_{max} max. Numero di giri n_{max}
Ø 63 mm	7.500 min ⁻¹
Ø 80 mm	6.000 min ⁻¹
Ø 100 mm	5.000 min ⁻¹
Ø 125 mm	4.000 min ⁻¹
Ø 160 mm	3.000 min ⁻¹
Ø 200 mm	2.500 min ⁻¹