

100/101



Lame et plaquettes

Profondeur de gorge 1,2 - 16 mm
Profondeur de gorge jusqu'à 55 mm

Lama e inserto

Profondità della gola 1,2 - 16 mm
Profondità della gola fino a 55 mm

Géométries et avances
Geometrie e avanzamenti

Page/Pag.
25-26

Porte outils
Portainsero
H100/H101

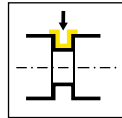

Page/Pag.
27-48, 74

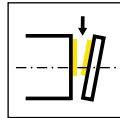

Page/Pag.
49-63

Plaquette
Inserto
S100/S101

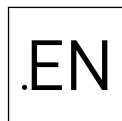

Page/Pag.
64, 67

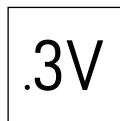

Page/Pag.
65, 71

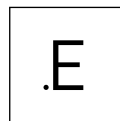

Page/Pag.
66

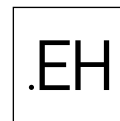

Page/Pag.
68

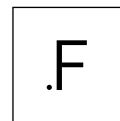

Page/Pag.
69

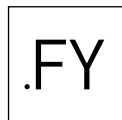

Page/Pag.
70

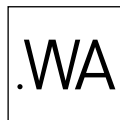

Page/Pag.
72

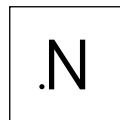

Page/Pag.
73

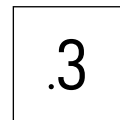

Page/Pag.
75

Géométries et avances

Geometrie e avanzamenti



A

Géométrie Geometria	Matière Materiale	Avance f [mm/trs] Avanzamento f [mm/giro]	Usinage Lavorazione						
	<table border="1"> <tr> <td>P</td> <td>M</td> <td>K</td> </tr> <tr> <td>N</td> <td>S</td> <td>H</td> </tr> </table>	P	M	K	N	S	H	<p>↓ 0,15-0,25</p> <p>↔ 0,15-0,40</p>	
P	M	K							
N	S	H							
	<table border="1"> <tr> <td>P</td> <td>M</td> <td>K</td> </tr> <tr> <td>N</td> <td>S</td> <td>H</td> </tr> </table>	P	M	K	N	S	H	<p>↓ 0,05-0,20</p>	
P	M	K							
N	S	H							
	<table border="1"> <tr> <td>P</td> <td>M</td> <td>K</td> </tr> <tr> <td>N</td> <td>S</td> <td>H</td> </tr> </table>	P	M	K	N	S	H	<p>↓ 0,08-0,30</p>	
P	M	K							
N	S	H							
	<table border="1"> <tr> <td>P</td> <td>M</td> <td>K</td> </tr> <tr> <td>N</td> <td>S</td> <td>H</td> </tr> </table>	P	M	K	N	S	H	<p>↓ 0,10-0,45</p>	
P	M	K							
N	S	H							
	<table border="1"> <tr> <td>P</td> <td>M</td> <td>K</td> </tr> <tr> <td>N</td> <td>S</td> <td>H</td> </tr> </table>	P	M	K	N	S	H	<p>↓ 0,03-0,15</p>	
P	M	K							
N	S	H							

Géométrie Geometria	Matière Materiale	Avance f [mm/trs] Avanzamento f [mm/giro]	Usinage Lavorazione						
	<table border="1"> <tr> <td>P</td> <td>M</td> <td>K</td> </tr> <tr> <td>N</td> <td>S</td> <td>H</td> </tr> </table>	P	M	K	N	S	H	<p>↓ 0,03-0,15</p>	
P	M	K							
N	S	H							
	<table border="1"> <tr> <td>P</td> <td>M</td> <td>K</td> </tr> <tr> <td>N</td> <td>S</td> <td>H</td> </tr> </table>	P	M	K	N	S	H	<p>↓ 0,05-0,25</p> <p>↔ 0,05-0,25</p>	
P	M	K							
N	S	H							
	<table border="1"> <tr> <td>P</td> <td>M</td> <td>K</td> </tr> <tr> <td>N</td> <td>S</td> <td>H</td> </tr> </table>	P	M	K	N	S	H	<p>↓ 0,07-0,25</p>	
P	M	K							
N	S	H							

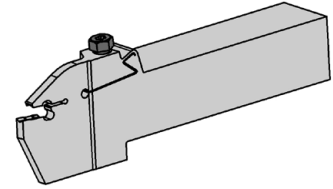
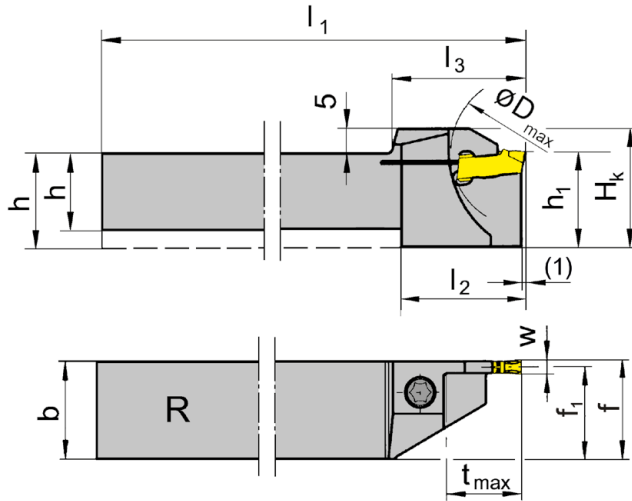
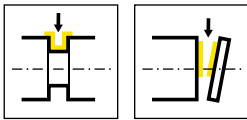

R = version à droite représentée
R = versione destra come in figura

L = version à gauche
L = versione sinistra a specchio

N° de commande Codice prodotto	h	b	l ₁	l ₂	l ₃	h ₁	f ₁	f	t _{max}	D _{max}	H _k	HWS
RH100.1010.01	10	10	125	19	21	13	9,25	f ₁ +w/2	10,5	21	18	100018
RH100.1010.11	10	10	125	21	23	16	9,25	f ₁ +w/2	13	42	21	100018
RH100.1212.01	12	12	125	21	23	16	11,25	f ₁ +w/2	13	26	21	100018
RH100.1212.11	12	12	125	21	26	16	11,25	f ₁ +w/2	16	42	21	100018
RH100.1616.11	16	16	125	24	26	20	15,25	f ₁ +w/2	16	42	25	100018
RH100.1616.21	16	16	125	30	33,5	20	15,25	f ₁ +w/2	21	42	25	100018
RH100.2020.11	20	20	125	-	26	20	19,25	f ₁ +w/2	16	42	25	100018
RH100.2020.21	20	20	125	-	33,5	20	19,25	f ₁ +w/2	21	42	25	100018
RH100.2525.21	25	25	150	-	33,5	25	24,3	f ₁ +w/2	21	42	30	100018
LH100.1010.01	10	10	125	19	21	13	9,25	f ₁ +w/2	10,5	21	18	100018
LH100.1010.11	10	10	125	21	23	16	9,25	f ₁ +w/2	13	42	21	100018
LH100.1212.01	12	12	125	21	23	16	11,25	f ₁ +w/2	13	26	21	100018
LH100.1212.11	12	12	125	21	26	16	11,25	f ₁ +w/2	16	42	21	100018
LH100.1616.11	16	16	125	24	26	20	15,25	f ₁ +w/2	16	42	25	100018
LH100.1616.21	16	16	125	30	33,5	20	15,25	f ₁ +w/2	21	42	25	100018
LH100.2020.11	20	20	125	-	33,5	20	19,25	f ₁ +w/2	16	42	25	100018
LH100.2020.21	20	20	125	-	33,5	20	19,25	f ₁ +w/2	21	42	25	100018
LH100.2525.21	25	25	150	-	33,5	25	24,3	f ₁ +w/2	21	42	30	100018

w voir plaquettes
w vd. inserti

Pièces Détachées

Ricambi

Porte outils Portainsero	Vis de serrage Vite di serraggio	Tournevis TORX PLUS® Cacciavite TORX PLUS®
R/LH100...	4.15T15P	T15PQ

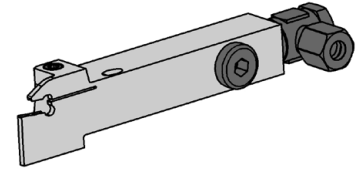
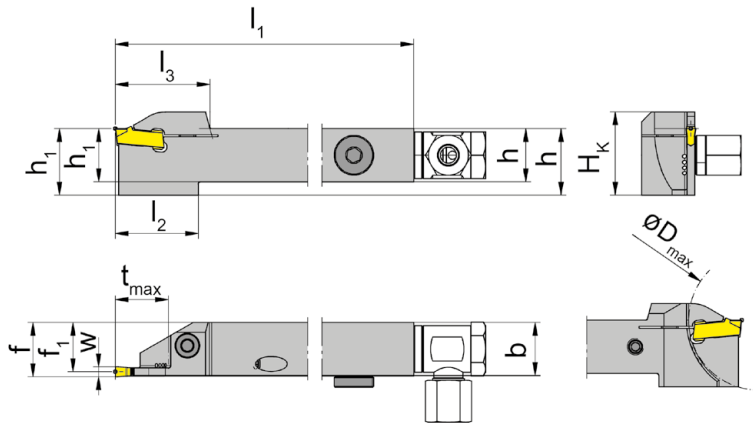
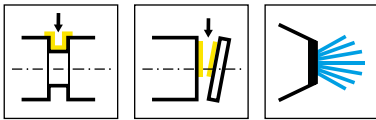

R = version à droite représentée
R = versione destra come in figura

L = version à gauche
L = versione sinistra a specchio

N° de commande Codice prodotto	h	b	l ₁	l ₂	l ₃	h ₁	f ₁	f	t _{max}	D _{max}	H _k	HWS
RH100.1212.01.IK	12	12	125	21	23	12	11,25	f ₁ +w/2	13	26	21	100018
RH100.1212.11.IK	12	12	125	21	26	12	11,25	f ₁ +w/2	16	42	21	100018
RH100.1616.11.IK	16	16	125	24	26	16	15,25	f ₁ +w/2	16	42	25	100018
RH100.1616.21.IK	16	16	125	30	33,5	16	15,25	f ₁ +w/2	21	42	25	100018
RH100.2020.11.IK	20	20	125	-	33,5	20	19,25	f ₁ +w/2	16	42	25	100018
RH100.2020.21.IK	20	20	125	-	33,5	20	19,25	f ₁ +w/2	21	42	25	100018
RH100.2525.21.IK	25	25	150	-	33,5	25	24,3	f ₁ +w/2	21	42	30	100018
LH100.1212.01.IK	12	12	125	21	23	12	11,25	f ₁ +w/2	13	26	21	100018
LH100.1212.11.IK	12	12	125	21	26	12	11,25	f ₁ +w/2	16	42	21	100018
LH100.1616.11.IK	16	16	125	24	26	16	15,25	f ₁ +w/2	16	42	25	100018
LH100.1616.21.IK	16	16	125	30	33,5	16	15,25	f ₁ +w/2	21	42	25	100018
LH100.2020.11.IK	20	20	125	-	33,5	20	19,25	f ₁ +w/2	16	42	25	100018
LH100.2020.21.IK	20	20	125	-	33,5	20	19,25	f ₁ +w/2	21	42	25	100018
LH100.2525.21.IK	25	25	150	-	33,5	25	24,3	f ₁ +w/2	21	42	30	100018

w voir plaquettes
w vd. inserti

Pièces Détachées

Ricambi

Porte outils Portainsero	Vis de serrage Vite di serraggio	Arrosage Lubrificazione	Tournevis TORX PLUS® Cacciavite TORX PLUS®	Vis Vite
R/LH100.1212...	4.15T15P	004.00.22	T15PQ	
R/LH100...	4.15T15P	004.00.16	T15PQ	004.00.26
R/LH100.2020.21.IK	4.15T15P	004.00.16	T20PQ	004.00.26

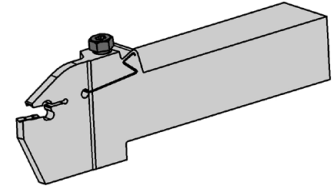
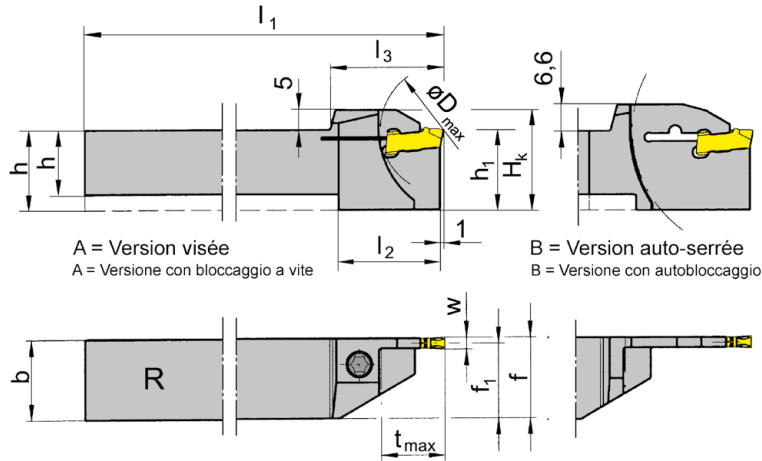
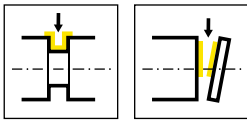

R = version à droite représentée
R = versione destra come in figura

L = version à gauche
L = versione sinistra a specchio

N° de commande Codice prodotto	h	b	l ₁	l ₂	l ₃	h ₁	f ₁	f	t _{max}	D _{max}	H _K	Forme Forma	HWS
RH100.1212.02	12	12	125	21	23	16	11,05	f ₁ +w/2	13	25	21	A	100028
RH100.1616.02	16	16	125	19	21	20	15,05	f ₁ +w/2	10,5	42	25	A	100028
RH100.1212.12	12	12	125	24	26	16	11,05	f ₁ +w/2	16	42	25	A	100028
RH100.1616.12	16	16	125	24	26	20	15,05	f ₁ +w/2	16	42	25	A	100028
RH100.2020.12	20	20	125	-	26	20	19,05	f ₁ +w/2	16	42	25	A	100028
RH100.1616.22	16	16	125	30	33,5	20	15,05	f ₁ +w/2	21	42	25	A	100028
RH100.2020.22	20	20	125	-	33,5	20	19,05	f ₁ +w/2	21	42	25	A	100028
RH100.2525.22	25	25	150	-	33,5	25	24,05	f ₁ +w/2	21	42	30	A	100028
RH100.2020.32	20	20	125	35	38,5	25	19,05	f ₁ +w/2	32,5	65	31,6	B	100028
LH100.1212.02	12	12	125	21	23	16	11,05	f ₁ +w/2	13	25	21	A	100028
LH100.1616.02	16	16	125	19	21	20	15,05	f ₁ +w/2	10,5	42	25	A	100028
LH100.1212.12	12	12	125	24	26	16	11,05	f ₁ +w/2	16	42	25	A	100028
LH100.1616.12	16	16	125	24	26	20	15,05	f ₁ +w/2	16	42	25	A	100028
LH100.2020.12	20	20	125	-	26	20	19,05	f ₁ +w/2	16	42	25	A	100028
LH100.1616.22	16	16	125	30	33,5	20	15,05	f ₁ +w/2	21	42	25	A	100028
LH100.2020.22	20	20	125	-	33,5	20	19,05	f ₁ +w/2	21	42	25	A	100028
LH100.2525.22	25	25	150	-	33,5	25	24,05	f ₁ +w/2	21	42	30	A	100028
LH100.2020.32	20	20	125	35	38,5	25	19,05	f ₁ +w/2	32,5	65	31,6	B	100028

w voir plaquettes
w vd. inserti

La clé P39L n'est pas fournie avec la lame R/LH100.2020.32 - à cder séparément!
La chiave P39L non viene fornita con la lama R/LH100.2020.32 - bisogna ordinarla separatamente!

Pièces Détachées

Ricambi

Porte outils Portainsero	Vis de serrage Vite di serraggio	Tournevis TORX PLUS® Cacciavite TORX PLUS®
R/LH100...	4.15T15P	T15PQ

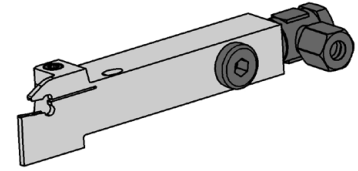
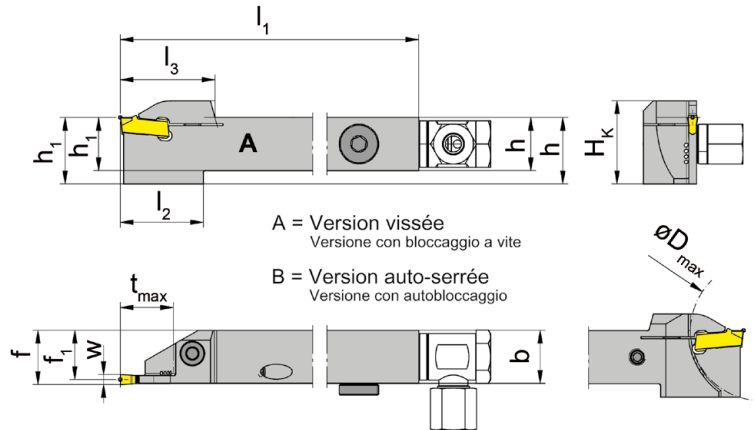
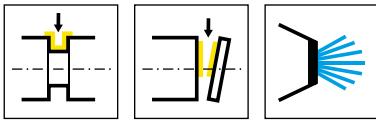

R = version à droite représentée
R = versione destra come in figura

L = version à gauche
L = versione sinistra a specchio

N° de commande Codice prodotto	h	b	l ₁	l ₂	l ₃	h ₁	f ₁	f	t _{max}	D _{max}	H _k	Forme Forma	HWS
RH100.1212.02.IK	12	12	125	21	23	16	11,05	f ₁ +w/2	13	25	21	A	100028
RH100.1616.02.IK	16	16	125	19	21	20	15,05	f ₁ +w/2	10,5	42	25	A	100028
RH100.1212.12.IK	12	12	125	24	26	16	11,05	f ₁ +w/2	16	42	25	A	100028
RH100.1616.12.IK	16	16	125	24	28,5	20	15,05	f ₁ +w/2	16	42	25	A	100028
RH100.2020.12.IK	20	20	125	-	26	20	19,05	f ₁ +w/2	16	42	25	A	100028
RH100.1616.22.IK	16	16	125	30	33,5	20	15,05	f ₁ +w/2	21	42	25	A	100028
RH100.2020.22.IK	20	20	125	-	33,5	20	19,05	f ₁ +w/2	21	42	25	A	100028
RH100.2525.22.IK	25	25	150	-	33,5	25	24,05	f ₁ +w/2	21	42	30	A	100028
LH100.1212.02.IK	12	12	125	21	23	16	11,05	f ₁ +w/2	13	25	21	A	100028
LH100.1616.02.IK	16	16	125	19	21	20	15,05	f ₁ +w/2	10,5	42	25	A	100028
LH100.1616.12.IK	16	16	125	24	28,5	20	15,05	f ₁ +w/2	16	42	25	A	100028
LH100.2020.12.IK	20	20	125	-	26	20	19,05	f ₁ +w/2	16	42	25	A	100028
LH100.1616.22.IK	16	16	125	30	33,5	20	15,05	f ₁ +w/2	21	42	25	A	100028
LH100.2020.22.IK	20	20	125	-	33,5	20	19,05	f ₁ +w/2	21	42	25	A	100028
LH100.2525.22.IK	25	25	150	-	33,5	25	24,05	f ₁ +w/2	21	42	30	A	100028

w voir plaquettes
w vd. inserti

Pièces Détachées

Ricambi

Porte outils Portainserito	Vis de serrage Vite di serraggio	Arrosage Lubrificazione	Tournevis TORX PLUS® Cacciavite TORX PLUS®	Vis Vite
RH100.1212.12.IK	4.15T15P	004.00.22	T15PQ	
R/LH100...	4.15T15P	004.00.16	T15PQ	004.00.26
R/LH100.2020.22.IK	5.17T20P		T20PQ	

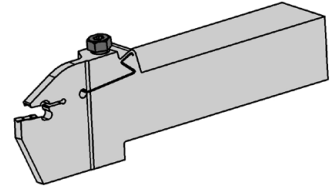
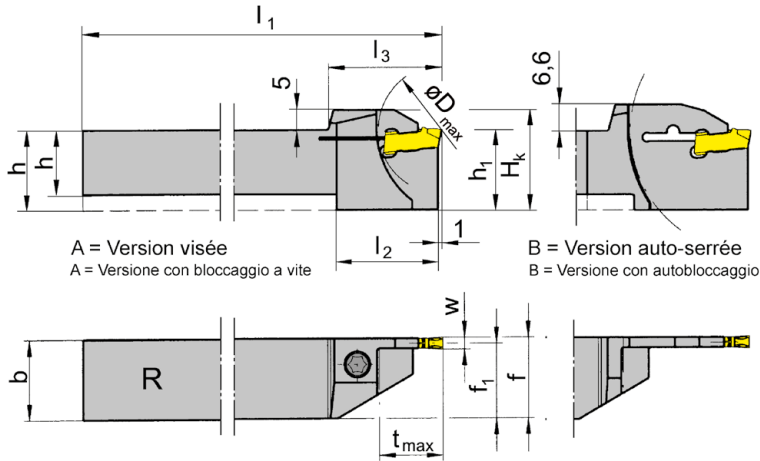
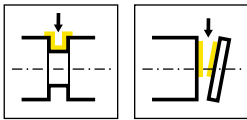

R = version à droite représentée
R = versione destra come in figura

L = version à gauche
L = versione sinistra a specchio

N° de commande Codice prodotto	h	b	l ₁	l ₂	l ₃	h ₁	f ₁	f	t _{max}	D _{max}	H _K	Forme Forma	HWS
RH100.1212.03	12	12	125	21	23	16	10,85	f ₁ +w/2	13	26	25	A	100028
RH100.1616.03	16	16	125	19,5	23	20	14,85	f ₁ +w/2	10,5	42	25	A	100038
RH100.1616.13	16	16	125	25	28,5	20	14,85	f ₁ +w/2	16	42	25	A	100038
RH100.1616.23	16	16	125	30	33,5	20	14,85	f ₁ +w/2	21	42	25	A	100038
RH100.2020.13	20	20	125	-	28,5	20	18,85	f ₁ +w/2	16	42	25	A	100038
RH100.2020.23	20	20	125	-	33,5	20	18,85	f ₁ +w/2	21	42	25	-	100038
RH100.2020.33	20	20	125	35	38,5	25	18,85	f ₁ +w/2	32,5	65	31,6	B	100038
RH100.2525.13	25	25	150	-	28,5	25	23,85	f ₁ +w/2	16	42	30	A	100038
RH100.2525.23	25	25	150	-	33,5	25	23,85	f ₁ +w/2	21	42	30	A	100038
RH100.2525.33	25	25	150	-	38,5	25	23,85	f ₁ +w/2	32,5	65	31,6	B	100038
LH100.1212.03	12	12	125	21	23	16	10,85	f ₁ +w/2	13	26	25	A	100028
LH100.1616.03	16	16	125	19,5	23	20	14,85	f ₁ +w/2	10,5	42	25	A	100038
LH100.1616.13	16	16	125	25	28,5	20	14,85	f ₁ +w/2	16	42	25	A	100038
LH100.1616.23	16	16	125	30	33,5	20	14,85	f ₁ +w/2	21	42	25	A	100038
LH100.2020.13	20	20	125	-	28,5	20	18,85	f ₁ +w/2	16	42	25	A	100038
LH100.2020.23	20	20	125	-	33,5	20	18,85	f ₁ +w/2	21	42	25	A	100038
LH100.2020.33	20	20	125	35	38,5	25	18,85	f ₁ +w/2	32,5	65	31,6	B	100038
LH100.2525.13	25	25	150	-	28,5	25	23,85	f ₁ +w/2	16	42	30	A	100038
LH100.2525.23	25	25	150	-	33,5	25	23,85	f ₁ +w/2	21	42	30	A	100038
LH100.2525.33	25	25	150	-	38,5	25	23,85	f ₁ +w/2	32,5	65	31,6	B	100038

w voir plaquettes
w vd. inserti

La clé P39L n'est pas fournie avec la lame R/LH100...33 - à cder séparément!
La chiave P39L non viene fornita con la lama R/LH100...33 - bisogna ordinarla separatamente!

Pièces Détachées

Ricambi

Porte outils Portainsero	Vis de serrage Vite di serraggio	Tournevis TORX PLUS® Cacciavite TORX PLUS®
R/LH100...	5.17T20P	T20PQ

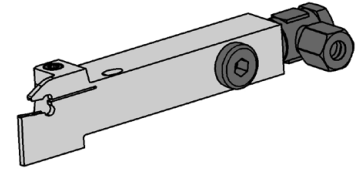
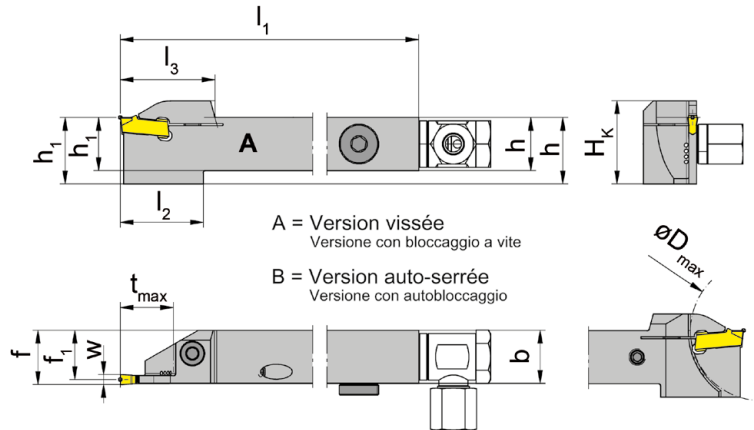
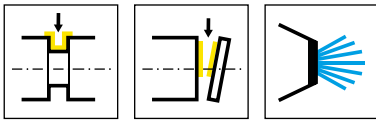

R = version à droite représentée
R = versione destra come in figura

L = version à gauche
L = versione sinistra a specchio

N° de commande Codice prodotto	h	b	l ₁	l ₂	l ₃	h ₁	f ₁	f	t _{max}	D _{max}	H _k	Forme Forma	HWS
RH100.1212.03.IK	12	12	125	21	23	16	10,85	f ₁ +w/2	13	26	25	A	100038
RH100.1616.03.IK	16	16	125	19,5	23	20	14,85	f ₁ +w/2	10,5	42	25	A	100038
RH100.1616.13.IK	16	16	125	25	28,5	20	14,85	f ₁ +w/2	16	42	25	A	100038
RH100.2020.13.IK	20	20	125	-	28,5	20	18,85	f ₁ +w/2	16	42	25	A	100038
RH100.1616.23.IK	16	16	125	30	33,5	20	14,85	f ₁ +w/2	21	42	25	A	100038
RH100.2020.23.IK	20	20	125	-	33,5	20	18,85	f ₁ +w/2	21	42	25	A	100038
RH100.2525.23.IK	25	25	150	-	33,5	25	23,85	f ₁ +w/2	21	42	30	A	100038
RH100.2020.33.IK	20	20	125	35	38,5	25	18,85	f ₁ +w/2	32,5	65	31,6	B	100038
RH100.2525.33.IK	25	25	150	-	38,5	25	23,85	f ₁ +w/2	32,5	65	31,6	B	100038
LH100.1212.03.IK	12	12	125	21	23	16	10,85	f ₁ +w/2	13	26	25	A	100038
LH100.1616.03.IK	16	16	125	19,5	23	20	14,85	f ₁ +w/2	10,5	42	25	A	100038
LH100.1616.13.IK	16	16	125	25	28,5	20	14,85	f ₁ +w/2	16	42	25	A	100038
LH100.2020.13.IK	20	20	125	-	28,5	20	18,85	f ₁ +w/2	16	42	25	A	100038
LH100.1616.23.IK	16	16	125	30	33,5	20	14,85	f ₁ +w/2	21	42	25	A	100038
LH100.2020.23.IK	20	20	125	-	33,5	20	18,85	f ₁ +w/2	21	42	25	A	100038
LH100.2525.23.IK	25	25	150	-	33,5	25	23,85	f ₁ +w/2	21	42	30	A	100038
LH100.2020.33.IK	20	20	125	35	38,5	25	18,85	f ₁ +w/2	32,5	65	31,6	B	100038
LH100.2525.33.IK	25	25	150	-	38,5	25	23,85	f ₁ +w/2	32,5	65	31,6	B	100038

w voir plaquettes
w vd. inserti

La clé **P39L** n'est pas fournie avec la lame R/LH100...33 - à cder séparément!
La chiave P39L non viene fornita con la lama R/LH100...33 - bisogna ordinarla separatamente!

Pièces Détachées

Ricambi

Porte outils Portainsero	Vis de serrage Vite di serraggio	Tournevis TORX PLUS® Cacciavite TORX PLUS®
R/LH100...	5.17T20P	T20PQ

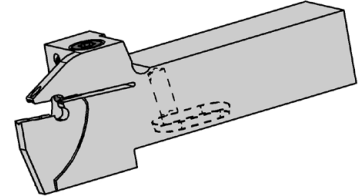
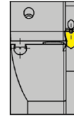
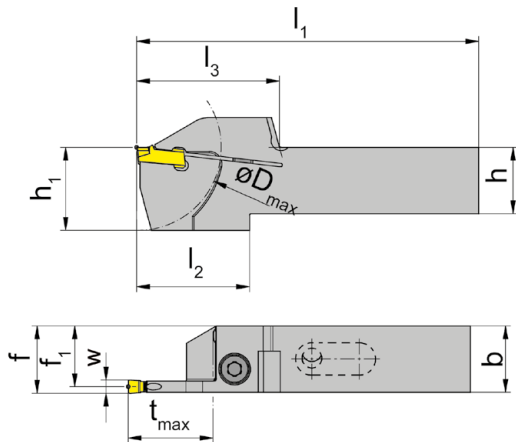
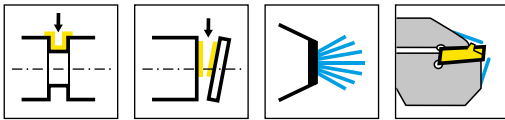

R = version à droite représentée
R = versione destra come in figura

L = version à gauche
L = versione sinistra a specchio

N° de commande Codice prodotto	h	b	l ₁	l ₂	l ₃	h ₁	f ₁	f	t _{max}	D _{max}	HWS
RH100.1616.2.23.IK	16	16	89	35	39	25	14,65	f ₁ +w/2	21,5	42	100038
RH100.2020.2.23.IK	20	20	102	33	39	25	18,65	f ₁ +w/2	21,5	42	100038
RH100.2020.2.73.IK	20	20	106	37	43	25	18,65	f ₁ +w/2	25,5	50	100038
RH100.2525.2.73.IK	25	25	121	37	43	30	23,65	f ₁ +w/2	25,5	50	100038
RH100.2020.34.4.73.IK	20	20	115	48	53	30	18,65	f ₁ +w/2	34	68	100038
RH100.2525.34.4.73.IK	25	25	132	48	53	35	23,65	f ₁ +w/2	34	68	100038
LH100.1616.2.23.IK	16	16	89	35	39	25	14,65	f ₁ +w/2	21,5	42	100038
LH100.2020.2.23.IK	20	20	102	33	39	25	18,65	f ₁ +w/2	21,5	42	100038
LH100.2020.2.73.IK	20	20	106	37	43	25	18,65	f ₁ +w/2	25,5	50	100038
LH100.2525.2.73.IK	25	25	121	37	43	30	23,65	f ₁ +w/2	25,5	50	100038
LH100.2020.34.4.73.IK	20	20	115	48	53	30	18,65	f ₁ +w/2	34	68	100038
LH100.2525.34.4.73.IK	25	25	132	48	53	35	23,65	f ₁ +w/2	34	68	100038

w voir plaquettes
w vd. inserti

Pièces Détachées

Ricambi

Porte outils Portainsero	Vis de serrage Vite di serraggio	Tournevis TORX PLUS® Cacciavite TORX PLUS®
R/LH100...	6.23T25P	T25PQ

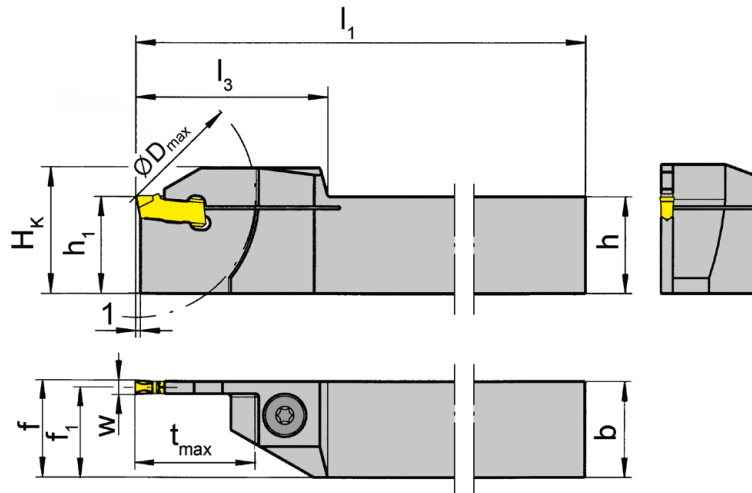
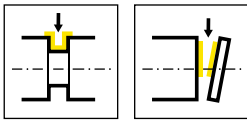

L = version à gauche représentée
L = versione sinistra come in figura

R = version à droite
R = versione destra a specchio

N° de commande Codice prodotto	h	b	l ₁	l ₃	h ₁	f ₁	f	t _{max}	D _{max}	H _K	HWS
RH100.2020.73	20	20	125	40	20	18,85	f ₁ +w/2	25	50	26	100038
RH100.2525.73	25	25	150	40	25	23,85	f ₁ +w/2	25	50	31	100038
RH100.2020.74	20	20	125	40	20	18,85	f ₁ +w/2	25	50	26	100048
LH100.2020.73	20	20	125	40	20	18,85	f ₁ +w/2	25	50	26	100038
LH100.2525.73	25	25	150	40	25	23,85	f ₁ +w/2	25	50	31	100038
LH100.2020.74	20	20	125	40	20	18,85	f ₁ +w/2	25	50	26	100048

w voir plaquettes
w vd. inserti

Pièces Détachées

Ricambi

Porte outils Portainserito	Vis de serrage Vite di serraggio	Tournevis TORX PLUS® Cacciavite TORX PLUS®
R/LH100...	6.23T25P	T25PQ

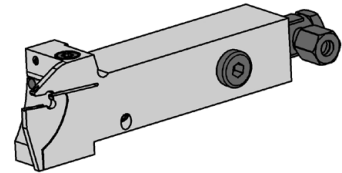
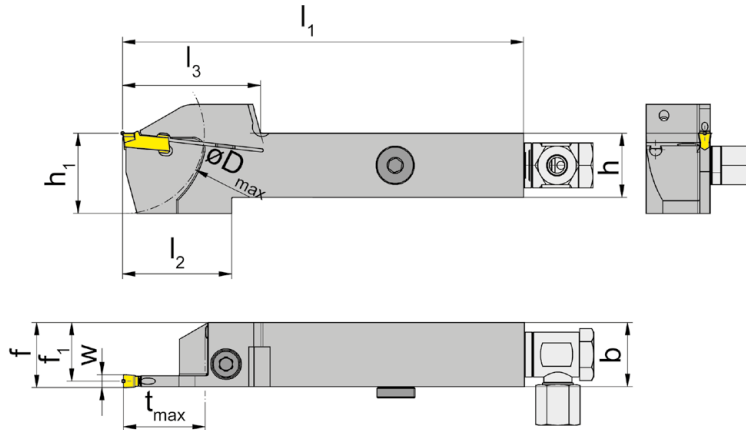
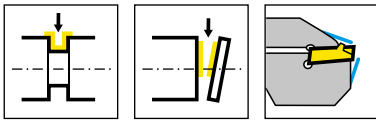

R = version à droite représentée
R = versione destra come in figura

L = version à gauche
L = versione sinistra a specchio

N° de commande Codice prodotto	h	b	l ₁	l ₂	l ₃	h ₁	f ₁	f	t _{max}	D _{max}	HWS
RH100.1616.0.23.IK	16	20	125	35	39	25	14,65	f ₁ +w/2	21,5	42	100038
RH100.1616.0.24.IK	16	20	125	35	39	25	14,3	f ₁ +w/2	21,5	42	100048
RH100.2020.0.23.IK	20	20	125	33	39	25	18,65	f ₁ +w/2	21,5	42	100038
RH100.2020.0.24.IK	20	20	125	33	39	25	18,3	f ₁ +w/2	21,5	42	100048
RH100.2525.0.23.IK	25	25	150	33	39	30	23,65	f ₁ +w/2	21,5	42	100038
RH100.2525.0.24.IK	25	25	150	33	39	30	23,3	f ₁ +w/2	21,5	42	100048
LH100.1616.0.23.IK	16	16	125	35	39	25	14,65	f ₁ +w/2	21,5	42	100038
LH100.1616.0.24.IK	16	16	125	35	39	25	14,3	f ₁ +w/2	21,5	42	100048
LH100.2020.0.23.IK	20	20	125	33	39	25	18,65	f ₁ +w/2	21,5	42	100038
LH100.2020.0.24.IK	20	20	125	33	39	25	18,3	f ₁ +w/2	21,5	42	100048
LH100.2525.0.23.IK	25	25	150	33	39	30	23,65	f ₁ +w/2	21,5	42	100038
LH100.2525.0.24.IK	25	25	150	33	39	30	23,3	f ₁ +w/2	21,5	42	100048

w voir plaquettes
w vd. inserti

Pièces Détachées

Ricambi

Porte outils Portainsero	Arrosage Lubrificazione	Vis de serrage Vite di serraggio	Tournevis TORX PLUS® Cacciavite TORX PLUS®	Vis Vite
R/LH100...	004.00.16	6.23T25P	T25PQ	004.00.26

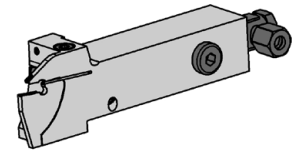
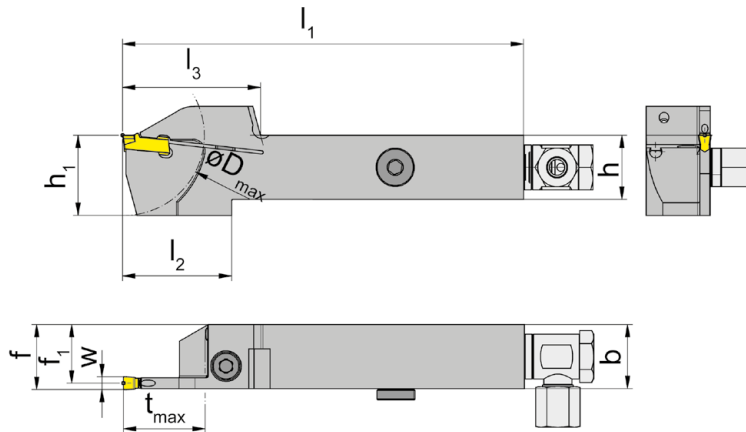
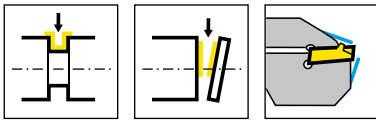

R = version à droite représentée
R = versione destra come in figura

L = version à gauche
L = versione sinistra a specchio

N° de commande Codice prodotto	h	b	l ₁	l ₂	l ₃	h ₁	f ₁	f	t _{max}	D _{max}	HWS
RH100.2020.0.73.IK	20	20	125	37	43	25	18,65	f ₁ +w/2	25,5	50	100038
RH100.2525.0.73.IK	25	25	150	37	43	30	23,65	f ₁ +w/2	25,5	50	100038
RH100.2525.0.74.IK	25	25	150	37	43	30	23,3	f ₁ +w/2	25,5	50	100048
LH100.2020.0.73.IK	20	20	125	37	43	25	18,65	f ₁ +w/2	25,5	50	100038
LH100.2525.0.73.IK	25	25	150	37	43	30	23,65	f ₁ +w/2	25,5	50	100038
LH100.2525.0.74.IK	25	25	150	37	43	30	23,3	f ₁ +w/2	25,5	50	100048
LH100.2020.0.74.IK	20	20	125	37	43	25	18,3	f ₁ +w/2	25,5	50	100048

w voir plaquettes
w vd. inserti

Pièces Détachées

Ricambi

Porte outils Portainsero	Arrosage Lubrificazione	Vis de serrage Vite di serraggio	Tournevis TORX PLUS® Cacciavite TORX PLUS®	Vis Vite
R/LH100....	004.00.16	6.23T25P	T25PQ	004.00.26

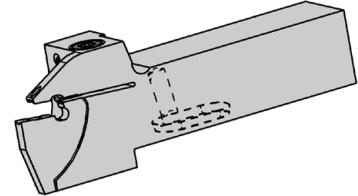
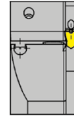
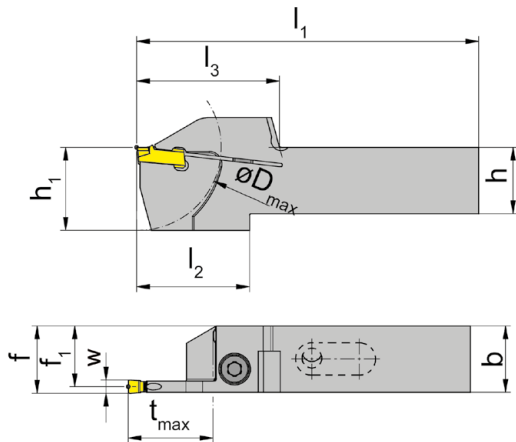
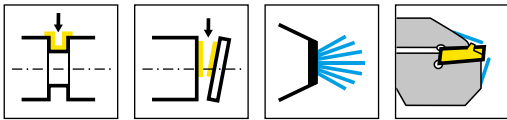

R = version à droite représentée
R = versione destra come in figura

L = version à gauche
L = versione sinistra a specchio

N° de commande Codice prodotto	h	b	l ₁	l ₂	l ₃	h ₁	f ₁	f	t _{max}	D _{max}	HWS
RH100.1616.2.24.IK	16	16	89	35	39	25	14,3	f ₁ +w/2	21,5	42	100048
RH100.2020.2.24.IK	20	20	102	33	39	25	18,3	f ₁ +w/2	21,5	42	100048
RH100.2020.2.74.IK	20	20	106	37	43	25	18,3	f ₁ +w/2	25,5	50	100048
LH100.1616.2.24.IK	16	16	89	35	39	25	14,3	f ₁ +w/2	21,5	42	100048
LH100.2020.2.24.IK	20	20	102	33	39	25	18,3	f ₁ +w/2	21,5	42	100048
LH100.2020.2.74.IK	20	20	106	37	43	25	18,3	f ₁ +w/2	25,5	50	100048

w voir plaquettes
w vd. inserti

Pièces Détachées

Ricambi

Porte outils Portainsero	Vis de serrage Vite di serraggio	Tournevis TORX PLUS® Cacciavite TORX PLUS®
R/LH100...	6.23T25P	T25PQ

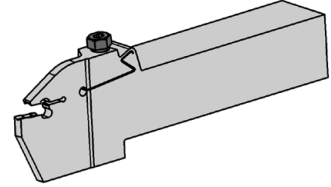
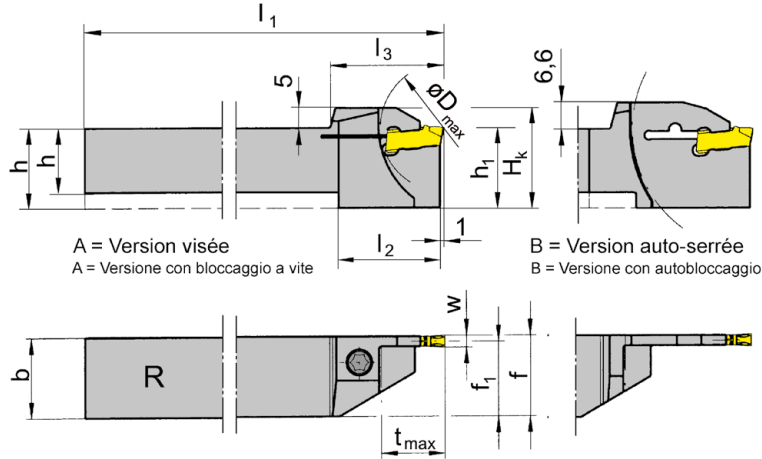
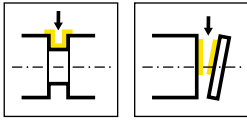

R = version à droite représentée
R = versione destra come in figura

L = version à gauche
L = versione sinistra a specchio

N° de commande Codice prodotto	h	b	l ₁	l ₂	l ₃	h ₁	f ₁	f	t _{max}	D _{max}	H _K	Forme Forma	HWS
RH100.1616.04	16	16	125	19,5	23	20	14,45	f ₁ +w/2	10,5	42	25	A	100048
RH100.1616.14	16	16	125	25	28,5	20	14,45	f ₁ +w/2	16	42	25	A	100048
RH100.2020.14	20	20	125	-	28,5	20	18,45	f ₁ +w/2	16	42	25	A	100048
RH100.2525.14	25	25	150	-	28,5	25	23,45	f ₁ +w/2	16	42	30	A	100048
RH100.2020.34	20	20	125	35	38,5	25	18,45	f ₁ +w/2	32,5	65	31,6	B	100048
RH100.2525.34	25	25	150	40	46,5	32	23,45	f ₁ +w/2	40,5	81	38,6	B	100048
LH100.1616.04	16	16	125	19,5	23	20	14,45	f ₁ +w/2	10,5	42	25	A	100048
LH100.1616.14	16	16	125	25	28,5	20	14,45	f ₁ +w/2	16	42	25	A	100048
LH100.2020.14	20	20	125	-	28,5	20	18,45	f ₁ +w/2	16	42	25	A	100048
LH100.2525.14	25	25	150	-	28,5	25	23,45	f ₁ +w/2	16	42	30	A	100048
LH100.1616.24	16	16	125	30	33,5	20	14,45	f ₁ +w/2	21	42	25	A	100048
LH100.2020.34	20	20	125	35	38,5	25	18,45	f ₁ +w/2	32,5	65	31,6	B	100048
LH100.2525.34	25	25	150	40	46,5	32	23,45	f ₁ +w/2	40,5	81	31,6	B	100048

w voir plaquettes
w vd. inserti

La clé **P39L** n'est pas fournie avec la lame R/LH100...34 - à cder séparément!
La chiave **P39L** non viene fornita con la lama R/LH100...34 - bisogna ordinarla separatamente!

Pièces Détachées

Ricambi

Porte outils Portainsero	Vis de serrage Vite di serraggio	Tournevis TORX PLUS® Cacciavite TORX PLUS®
R/LH100....	5.17T20P	T20PQ

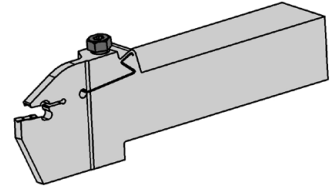
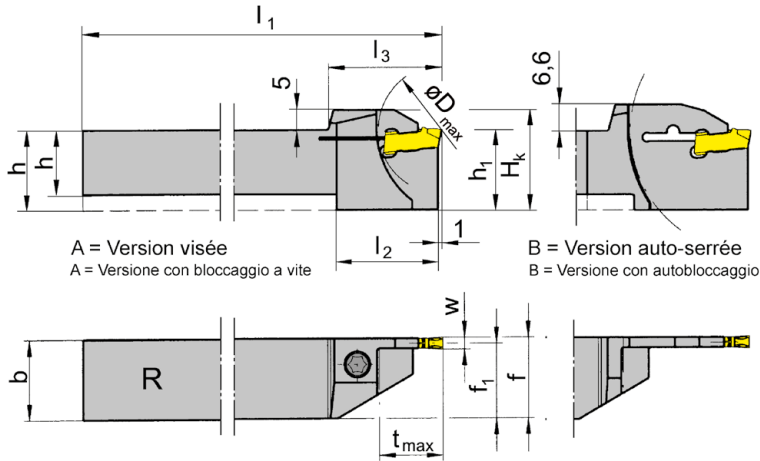
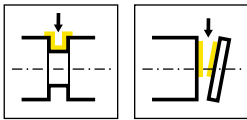

R = version à droite représentée
R = versione destra come in figura

L = version à gauche
L = versione sinistra a specchio

N° de commande Codice prodotto	h	b	l ₁	l ₂	l ₃	h ₁	f ₁	f	t _{max}	D _{max}	H _K	Forme Forma	HWS
RH100.2020.15	20	20	125	-	28,5	20	18,05	f ₁ +w/2	16	42	25	A	100058
RH100.2525.15	25	25	150	-	28,5	25	23,05	f ₁ +w/2	16	42	30	A	100058
RH100.2020.35	20	20	125	35	38,5	20	18,05	f ₁ +w/2	32,5	65	31,6	B	100058
RH100.2525.35	25	25	150	40	46,5	32	23,05	f ₁ +w/2	40,5	81	38,6	B	100058
LH100.2020.15	20	20	125	-	28,5	20	18,05	f ₁ +w/2	16	42	25	A	100058
LH100.2525.15	25	25	150	-	28,5	25	23,05	f ₁ +w/2	16	42	30	A	100058
LH100.2020.35	20	20	125	35	38,5	25	18,05	f ₁ +w/2	32,5	65	31,6	B	100058
LH100.2525.35	25	25	150	40	46,5	32	23,05	f ₁ +w/2	40,5	81	38,6	B	100058

w voir plaquettes
w vd. inserti

La clé P39L n'est pas fournie avec la lame R/LH100...35 - à cder séparément!
La chiave P39L non viene fornita con la lama R/LH100...35 - bisogna ordinarla separatamente!

Pièces Détachées

Ricambi

Porte outils Portainsero	Vis de serrage Vite di serraggio	Tournevis TORX PLUS® Cacciavite TORX PLUS®
R/LH100....	5.17T20P	T20PQ

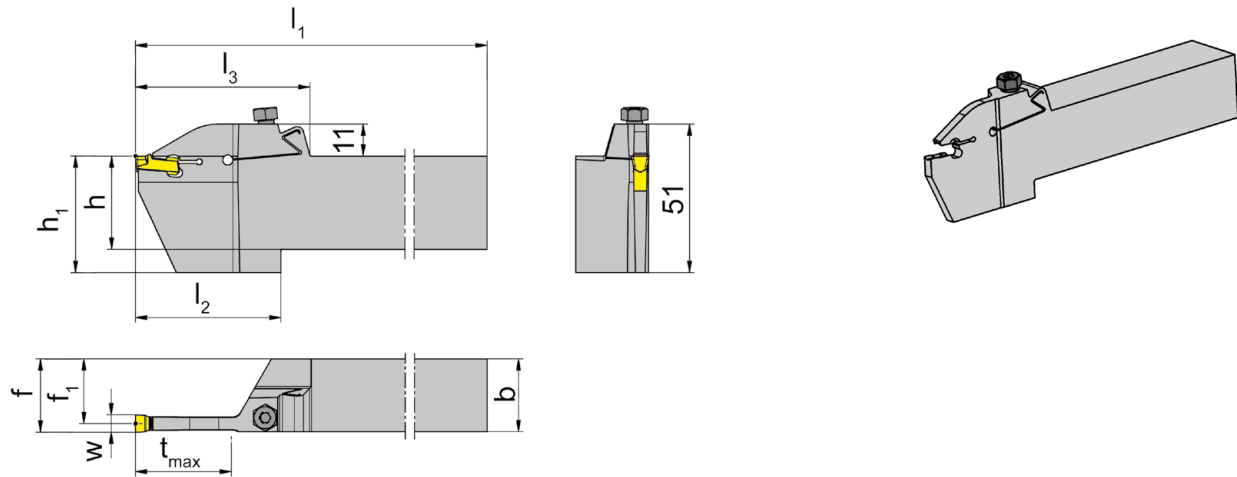
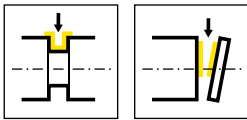

R = version à droite représentée
R = versione destra come in figura

L = version à gauche
L = versione sinistra a specchio

N° de commande Codice prodotto	h	b	l_1	l_2	l_3	h_1	f_1	f	t_{max}	HWS
RH100.2020.3.04	20	20	150	50	60	32	18,2	$f_1+w/2$	33	100048
RH100.2020.3.05	20	20	150	50	60	32	17,7	$f_1+w/2$	33	100058
RH100.2525.3.05	25	25	150	50	60	32	22,7	$f_1+w/2$	33	100058
RH100.2525.3.06	25	25	150	50	60	40	22,2	$f_1+w/2$	33	100068
RH100.3225.3.06	32	25	170	50	60	40	22,2	$f_1+w/2$	33	100068
RH100.3225.3.08	32	25	170	50	60	40	21,2	$f_1+w/2$	33	100088
RH100.3225.3.8	32	25	170	50	60	40	21,2	$f_1+w/2$	35	100088
RH100.3225.4.08	32	25	170	55	65	40	21,2	$f_1+w/2$	41	100088
RH100.3225.4.10	32	25	170	55	65	40	20,3	$f_1+w/2$	41	100108
RH100.3225.4.12	32	25	170	55	65	40	19,3	$f_1+w/2$	41	100128
LH100.2020.3.04	20	20	150	50	60	32	18,2	$f_1+w/2$	33	100048
LH100.2020.3.05	20	20	150	50	60	32	17,7	$f_1+w/2$	33	100058
LH100.2525.3.05	25	25	150	50	60	32	22,7	$f_1+w/2$	33	100058
LH100.2525.3.06	25	25	150	50	60	40	22,2	$f_1+w/2$	33	100068
LH100.3225.3.06	32	25	170	50	60	40	22,2	$f_1+w/2$	33	100068
LH100.3225.3.08	32	25	170	50	60	40	21,2	$f_1+w/2$	33	100088
LH100.3225.3.8	32	25	170	50	60	40	21,2	$f_1+w/2$	35	100088
LH100.3225.4.08	32	25	170	55	65	40	21,2	$f_1+w/2$	41	100088
LH100.3225.4.10	32	25	170	55	65	40	20,3	$f_1+w/2$	41	100108
LH100.3225.4.12	32	25	170	55	65	40	19,3	$f_1+w/2$	41	100128

w voir plaquettes
w vd. inserti

Pièces Détachées

Ricambi

Porte outils Portainsero	Vis de serrage Vite di serraggio	Tournevis TORX PLUS® Cacciavite TORX PLUS®
R/LH100...	030.6075.T20P	T20PQ

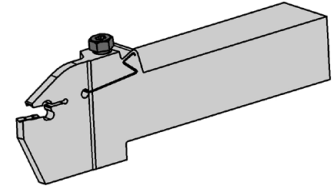
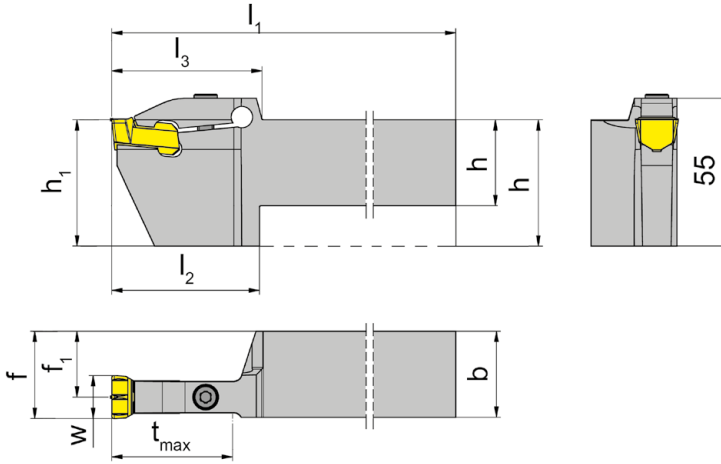
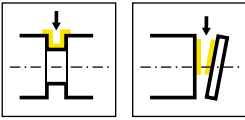

R = version à droite représentée
R = versione destra come in figura

L = version à gauche
L = versione sinistra a specchio

N° de commande Codice prodotto	h	b	l ₁	l ₂	h ₁	f ₁	f	t _{max}	l ₃	HWS
RH100.3232.5.16	32	32	170	55	47	24,5	f ₁ +w/2	45	56	100068
LH100.3232.5.16	32	32	170	55	47	24,5	f ₁ +w/2	45	56	100068

w voir plaquettes
w vd. inserti

Pièces Détachées

Ricambi

Porte outils Portainsero	Vis de serrage Vite di serraggio	Tournevis TORX PLUS® Cacciavite TORX PLUS®
R/LH100.3232.5.16	030.0625.T25P	T25PQ

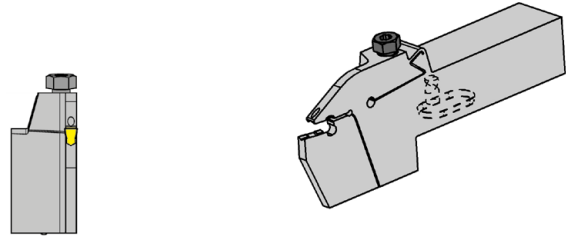
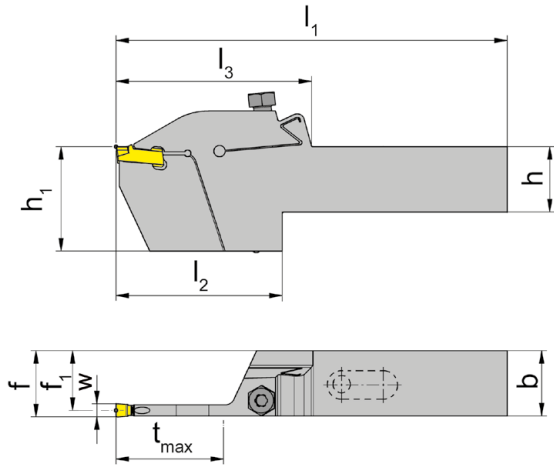
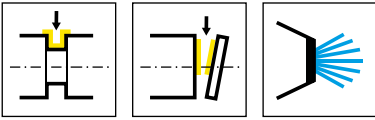

R = version à droite représentée
R = versione destra come in figura

L = version à gauche
L = versione sinistra a specchio

N° de commande Codice prodotto	h	b	l ₁	l ₂	l ₃	h ₁	f ₁	f	t _{max}	HWS
RH100.2020.3.2.04.IK	20	20	120	51	60	32	18,3	f ₁ +w/2	33	100048
RH100.2525.3.2.04.IK	25	25	134	50	60	32	23,3	f ₁ +w/2	33	100048
LH100.2020.3.2.04.IK	20	20	120	51	60	32	18,3	f ₁ +w/2	33	100048
LH100.2525.3.2.04.IK	25	25	134	50	60	32	23,3	f ₁ +w/2	33	100048

w voir plaquettes
w vd. inserti

Pièces Détachées

Ricambi

Porte outils Portainsero	Vis de serrage Vite di serraggio	Tournevis TORX PLUS® Cacciavite TORX PLUS®
R/LH100...	030.6075.T20P	T20PQ

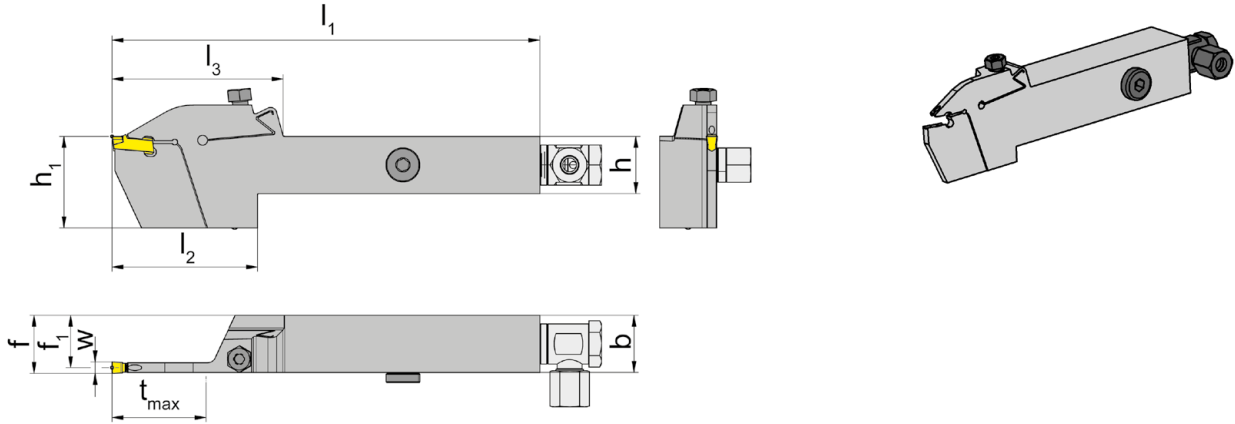
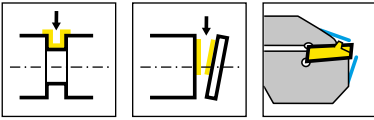

R = version à droite représentée
R = versione destra come in figura

L = version à gauche
L = versione sinistra a specchio

N° de commande Codice prodotto	h	b	l_1	l_2	l_3	h_1	f_1	f	t_{max}	HWS
RH100.2020.3.0.04.IK	20	20	150	51	60	32	18,3	$f_1+w/2$	33	100048
RH100.2525.3.0.04.IK	25	25	150	50	60	32	23,3	$f_1+w/2$	33	100048
LH100.2020.3.0.04.IK	20	20	150	51	60	32	18,3	$f_1+w/2$	33	100048
LH100.2525.3.0.04.IK	25	25	150	50	60	32	23,3	$f_1+w/2$	33	100048

w voir plaquettes
w vd. inserti

Pièces Détachées

Ricambi

Porte outils Portainsero	Arrosage Lubrificazione	Vis de serrage Vite di serraggio	Tournevis TORX PLUS® Cacciavite TORX PLUS®	Vis Vite
R/LH100...	004.00.16	030.6075.T20P	T20PQ	004.00.26

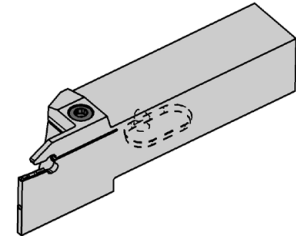
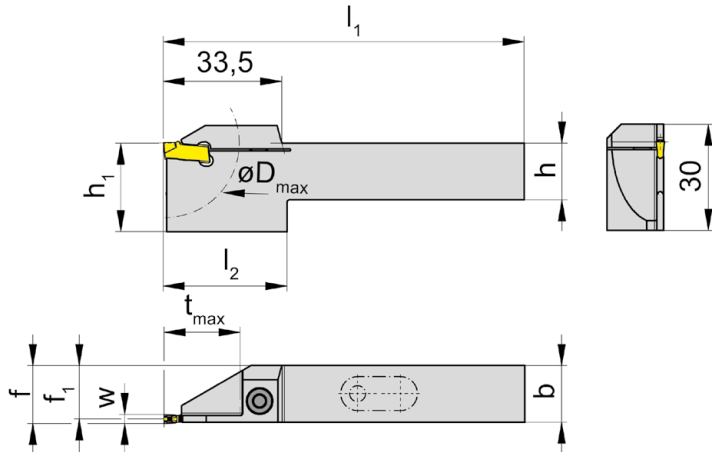
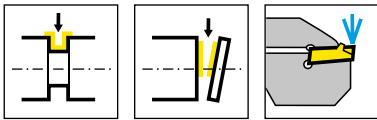

R = version à droite représentée
R = versione destra come in figura

L = version à gauche
L = versione sinistra a specchio

N° de commande Codice prodotto	h	b	l ₁	l ₂	h ₁	f ₁	f	t _{max}	D _{max}	HWS
RH100.2020.3.22.IK	20	20	102	35	25	19,05	f ₁ +w/2	21,5	42	100029
LH100.1616.3.22.IK	16	16	89	35	25	15,05	f ₁ +w/2	21,5	42	100029
LH100.2020.3.22.IK	20	20	102	35	25	19,05	f ₁ +w/2	21,5	42	100029

w voir plaquettes
w vd. inserti

Pièces Détachées

Ricambi

Porte outils Portainsero	Vis de serrage Vite di serraggio	Tournevis TORX PLUS® Cacciavite TORX PLUS®
R/LH100...	5.17T20P	T20PQ

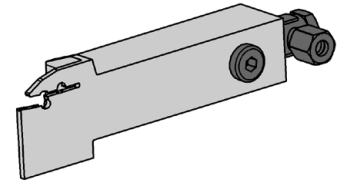
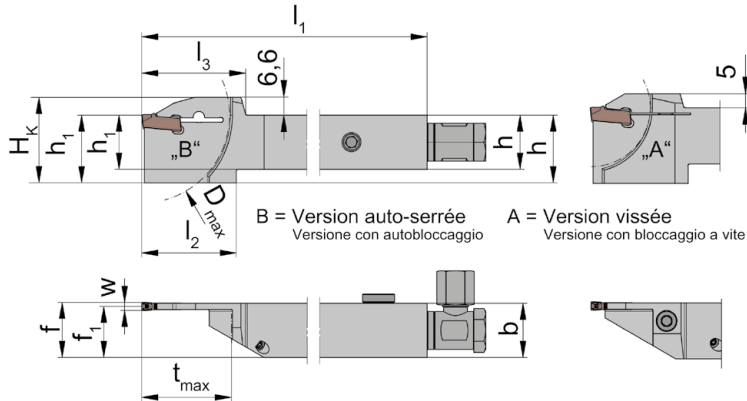
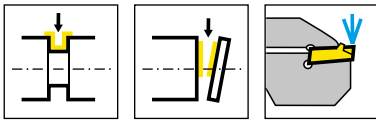

L = version à gauche représentée
L = versione sinistra come in figura

R = version à droite
R = versione destra a specchio

N° de commande Codice prodotto	h	b	l ₁	l ₂	l ₃	h ₁	f ₁	f	t _{max}	D _{max}	H _K	Forme Forma	HWS
RH100.1616.1.23.IK	16	16	125	35	33,5	27	14,85	f ₁ +w/2	21,5	42	32	A	100039
RH100.2020.1.13.IK	20	20	125	30	28,5	27	18,85	f ₁ +w/2	16	42	32	A	100039
RH100.2020.1.23.IK	20	20	125	35	33,5	27	18,85	f ₁ +w/2	21,5	42	32	A	100039
RH100.2020.1.33.IK	20	20	125	35	38,5	27	18,85	f ₁ +w/2	33	65	33,6	B	100039
RH100.2020.1.34.IK	20	20	125	35	38,5	27	18,45	f ₁ +w/2	33	65	33,6	B	100039
RH100.2525.1.33.IK	25	25	150	35	38,5	32	23,85	f ₁ +w/2	33	65	38,6	B	100039
RH100.2525.1.34.IK	25	25	150	40	46,5	32	23,45	f ₁ +w/2	41	81	38,6	B	100039
LH100.1616.1.23.IK	16	16	125	35	33,5	27	14,85	f ₁ +w/2	21,5	42	32	A	100039
LH100.2020.1.13.IK	20	20	125	30	28,5	27	18,85	f ₁ +w/2	16	42	32	A	100039
LH100.2020.1.23.IK	20	20	125	35	33,5	27	18,85	f ₁ +w/2	21,5	42	32	A	100039
LH100.2020.1.33.IK	20	20	125	35	38,5	27	18,85	f ₁ +w/2	33	65	33,6	B	100039
LH100.2525.1.33.IK	25	25	150	35	38,5	32	23,85	f ₁ +w/2	33	65	38,6	B	100039
LH100.2525.1.34.IK	25	25	150	40	46,5	32	23,45	f ₁ +w/2	41	81	38,6	B	100039

w voir plaquettes
w vd. inserti

La clé P39L n'est pas fournie avec la lame H100...33/...34 - à cder séparément!
La chiave P39L non viene fornita con la lama H100...33/...34 - bisogna ordinarla separatamente!

Pièces Détachées

Ricambi

Porte outils Portainsero	Vis de serrage Vite di serraggio	Arrosage Lubrificazione	Tournevis TORX PLUS® Cacciavite TORX PLUS®	Vis Vite	Clé Chiave
R/LH100...	5.17T20P	004.00.16	T20PQ	004.00.26	
R/LH...33.IK/...34.IK		004.00.16		004.00.26	P39L

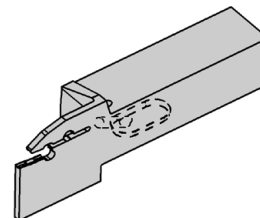
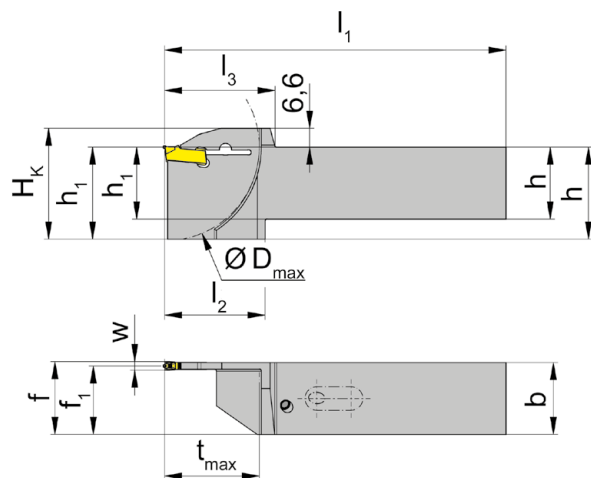
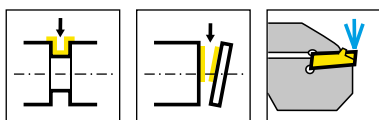

L = version à gauche représentée

R = version à droite

L = versione sinistra come in figura

R = versione destra a specchio

N° de commande Codice prodotto	h	b	l ₁	l ₂	l ₃	h ₁	f ₁	f	t _{max}	D _{max}	H _K	HWS
RH100.2020.3.33.IK	20	20	104	35	38,5	27	18,85	f ₁ +w/2	33	65	33,6	100039
RH100.2525.3.33.IK	25	25	119	35	38,5	32	23,85	f ₁ +w/2	33	65	38,6	100039
LH100.2020.3.33.IK	20	20	104	35	38,5	27	18,85	f ₁ +w/2	33	65	33,6	100039
LH100.2525.3.33.IK	25	25	119	35	38,5	32	23,85	f ₁ +w/2	33	65	38,6	100039

w voir plaquettes

w vd. inserti

La clé **P39L** n'est pas fournie avec la lame R/LH100...33 - à cder séparément!

La chiave **P39L** non viene fornita con la lama R/LH100...33 - bisogna ordinarla separatamente!

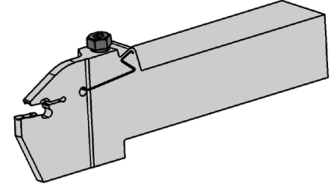
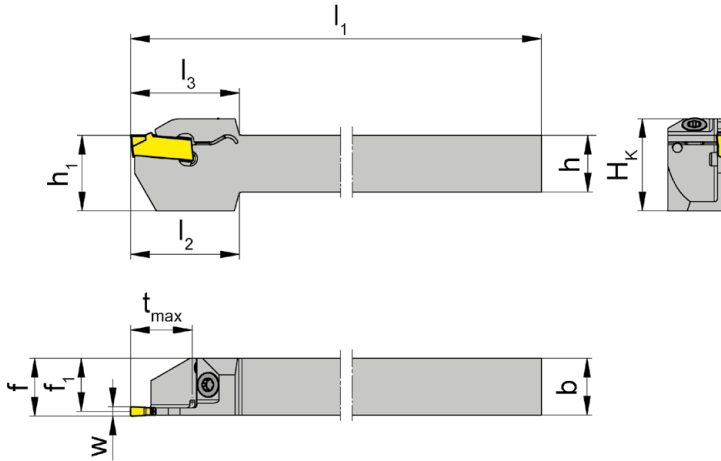
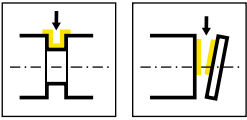

R = version à droite représentée
R = versione destra come in figura

L = version à gauche
L = versione sinistra a specchio

N° de commande Codice prodotto	h	b	l ₁	l ₂	l ₃	h ₁	f ₁	f	t _{max}	D _{max}	H _k	HWS
RH100.1212.24.61	12	12	125	23	23	16	11,25	f ₁ +w/2	13	26	19,5	100018
RH100.1212.32.63	12	12	125	27	24	16	10,85	f ₁ +w/2	17	34	19,5	100038
RH100.1616.24.61	16	16	125	23	-	16	15,25	f ₁ +w/2	13	26	19,5	100018
RH100.1616.32.63	16	16	125	27	-	16	14,85	f ₁ +w/2	17	34	19,5	100038
LH100.1212.24.61	12	12	125	23	23	16	11,25	f ₁ +w/2	13	26	19,5	100018
LH100.1212.32.63	12	12	125	24	27	16	10,85	f ₁ +w/2	17	34	19,5	100038
LH100.1616.24.61	16	16	125	-	23	16	15,25	f ₁ +w/2	13	26	19,5	100018
LH100.1616.32.63	16	16	125	-	27	16	14,85	f ₁ +w/2	17	34	19,5	100038

w voir plaquettes
w vd. inserti

Pièces Détachées

Ricambi

Porte outils Portainsero	Vis de serrage Vite di serraggio	Tournevis TORX PLUS® Cacciavite TORX PLUS®
R/LH100...	3.5.12T10EP	T10PL

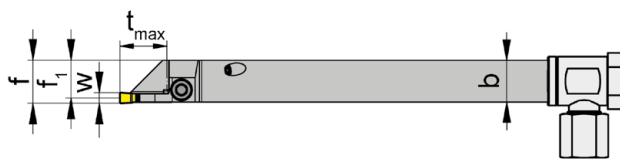
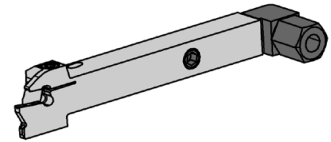
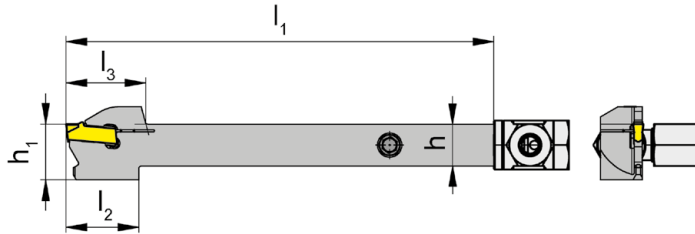
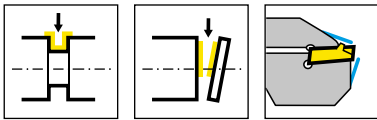

R = version à droite représentée
R = versione destra come in figura

L = version à gauche
L = versione sinistra a specchio

N° de commande Codice prodotto	h	b	l_1	l_2	l_3	h_1	f_1	f	t_{max}	D_{max}	HWS
RH100.1212.5.23.IK	12	12	125	21	23	16	10,85	$f_1+w/2$	13,5	26	100038
LH100.1212.5.23.IK	12	12	125	21	23	16	10,85	$f_1+w/2$	13,5	26	100038

w voir plaquettes
w vd. inserti

Pièces Détachées

Ricambi

Porte outils Portainsero	Vis de serrage Vite di serraggio	Arrosage Lubrificazione	Tournevis TORX PLUS® Cacciavite TORX PLUS®
R/LH100.1212.5.23.IK	4.15T15P	004.00.61	T15PQ

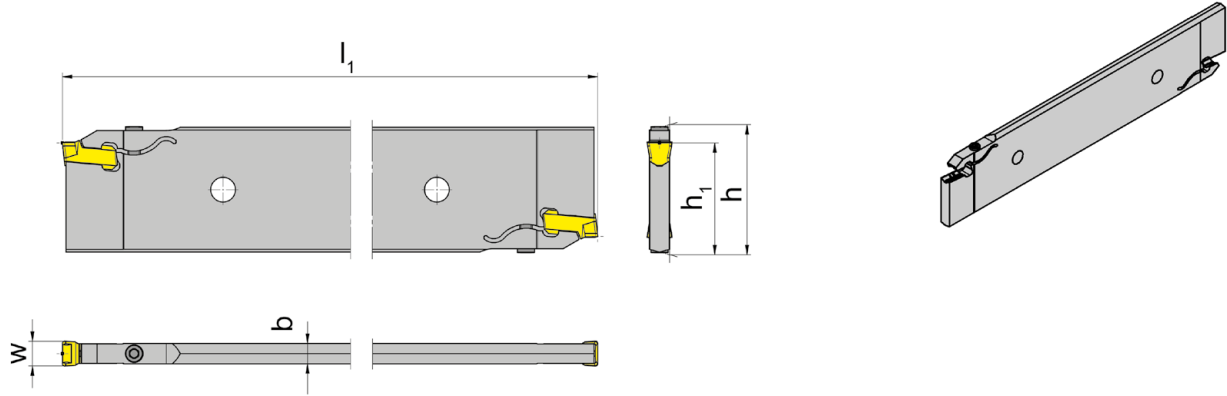
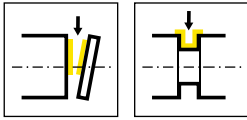

N° de commande Codice prodotto	h	b	l ₁	h ₁	HWS
H100.5208.26.08	52,6	7,4	260	45	100088
H100.5210.26.10	52,6	8,2	260	45	100108
H100.5212.26.12	52,6	10,4	260	45	100128

w voir plaquettes
w vd. inserti

Pièces Détachées

Ricambi

Porte outils Portainsero	Vis de serrage Vite di serraggio	Tournevis TORX PLUS® Cacciavite TORX PLUS®
H100...	5.13T20P	T20PQ

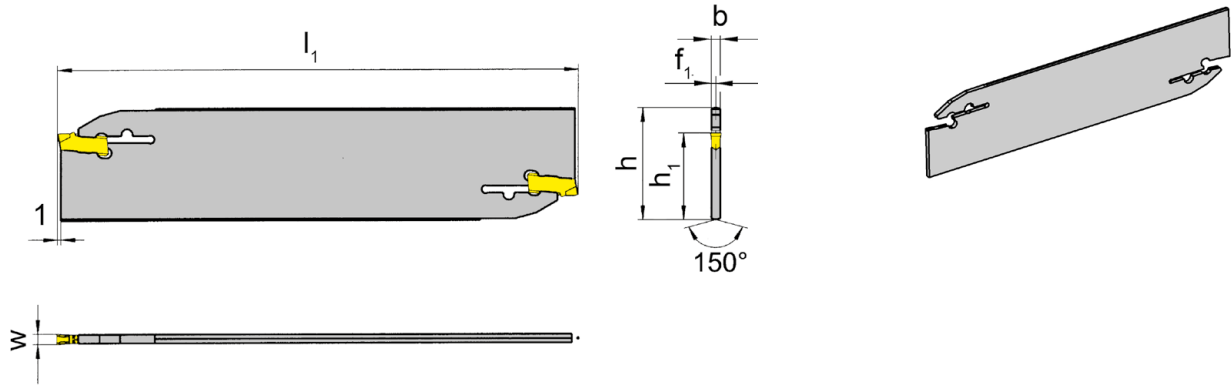
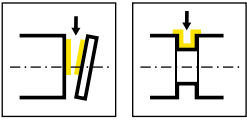

N° de commande Codice prodotto	h	b	l_1	h_1	f_1	t_{max}	HWS
H100.2601.01	26	1,5	110	21,4	0,75	25	100018
H100.2602.02	26	1,9	110	21,4	0,95	37,5	100028
H100.2603.03	26	2,3	110	21,4	1,15	37,5	100038
H100.2604.04	26	3,1	110	21,8	1,65	40	100048
H100.3201.01	32	1,5	150	24,8	0,75	25	100018
H100.3202.02	32	1,9	150	24,8	0,95	50	100028
H100.3203.03	32	2,3	150	24,8	1,15	50	100038
H100.3204.04	32	3,1	160	24,8	1,65	55	100048
H100.3205.05	32	3,9	160	24,8	2	55	100058

w voir plaquettes
w vd. inserti

La clé P39L n'est pas fournie avec le porte outils - à cder séparément!
La chiave P39L non viene fornita con la portainsero - bisogna ordinarla separatamente!

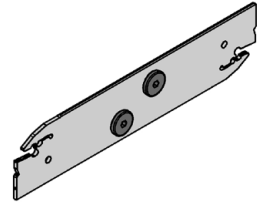
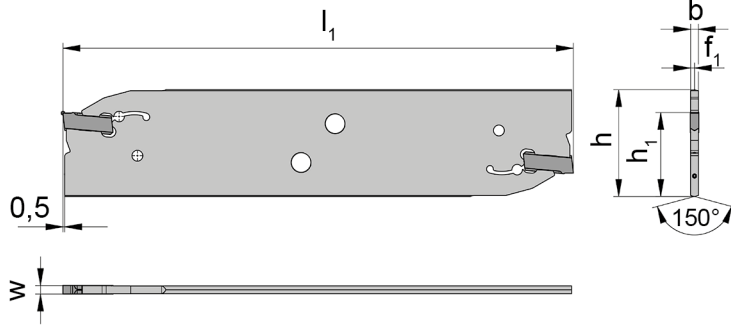
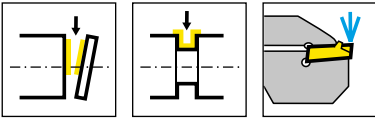

N° de commande Codice prodotto	h	b	l ₁	h ₁	f ₁	t _{max}	HWS
H100.2602.8.02.IK	26	1,9	110	21,4	0,95	35	100029 • 100028
H100.2603.8.03.IK	26	2,3	110	21,4	1,15	35	100039 • 100038
H100.2604.8.04.IK	26	3,1	110	21,4	1,55	35	100049 • 100048
H100.3202.8.02.IK	32	1,9	150	24,8	0,95	55	100029 • 100028
H100.3203.8.03.IK	32	2,3	150	24,8	1,15	60	100039 • 100038
H100.3204.8.04.IK	32	3,1	150	24,8	1,55	60	100049 • 100048

La clé P101.02 n'est pas fournie avec le fraise - à cder séparément!
La chiave P101.02 non viene fornita con fresa - bisogna ordinarla separatamente!

Pièces Détachées

Ricambi

Porte outils Portainsero	Bouchon de réfrigérant Tappo del refrigerante
H100...	020.IK01.5732

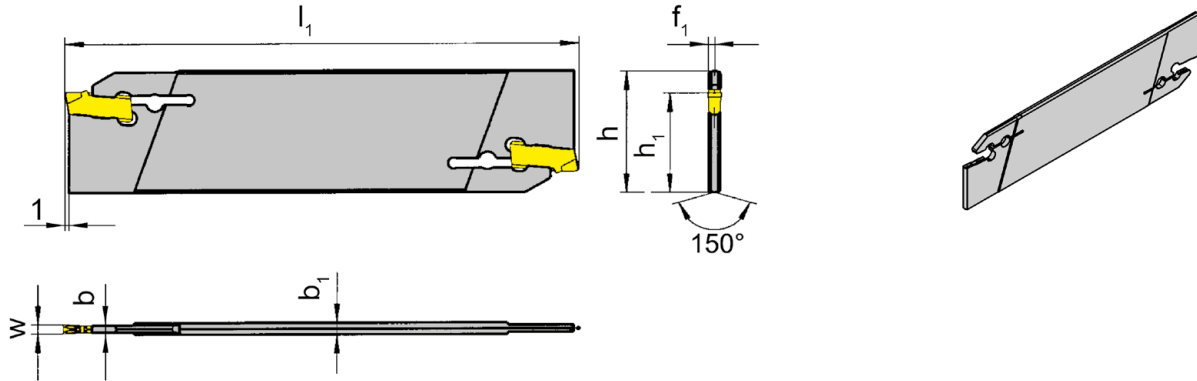
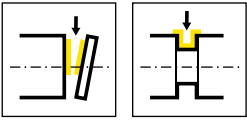

N° de commande Codice prodotto	h	b	l_1	h_1	f_1	t_{max}	b_1	HWS
H100.2603.01	26	1,5	110	21,4	1,15	21	2,3	100018
H100.2603.02	26	1,9	110	21,4	1,15	21	2,3	100028
H100.3203.01	32	1,5	150	24,8	1,15	25	2,3	100018
H100.3203.02	32	1,9	150	24,8	1,15	25	2,3	100028

La clé P39L n'est pas fournie avec le porte outils - à cder séparément!
 La chiave P39L non viene fornita con la portainserto - bisogna ordinarla separatamente!

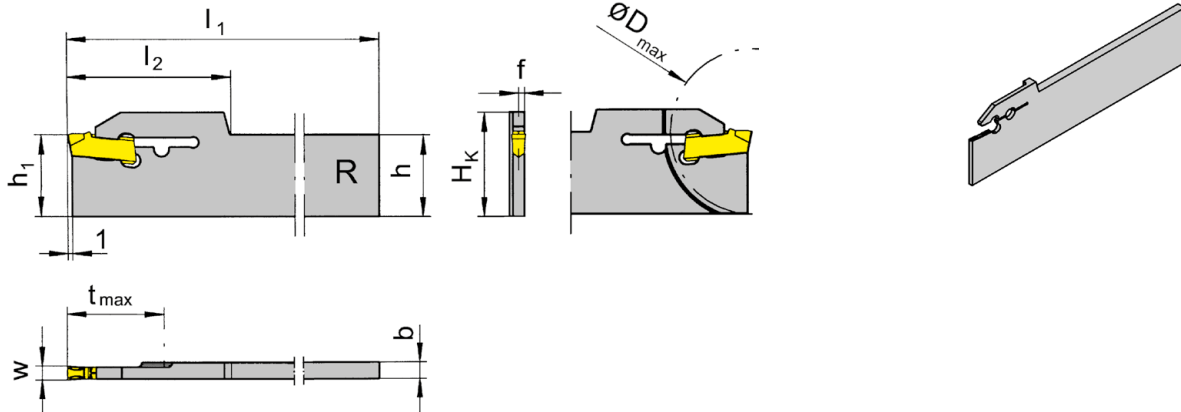
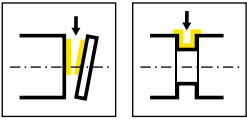

R = version à droite

R = versione destra

N° de commande Codice prodotto	H _K	b	l ₁	h ₁	f	l ₂	t _{max}	D _{max}	h	HWS
RH100.1703.21	22,1	3,2	110	17,4	0,75	32	17,5	35	17,4	100018
RH100.2203.21	26,9	3,2	150	22,2	0,75	32	32	50	22,1	100018
RH100.1703.33	22,1	3,2	110	17,4	1,15	34,5	30	60	17,4	100038
RH100.2203.33	26,9	3,2	150	22,2	1,15	34,5	38	76	22,1	100038

w voir plaquettes

w vd. inserti

La clé **P39L** n'est pas fournie avec la lame R/LH100...33 - à cder séparément!

La chiave **P39L** non viene fornita con la lama R/LH100...33 - bisogna ordinarla separatamente!

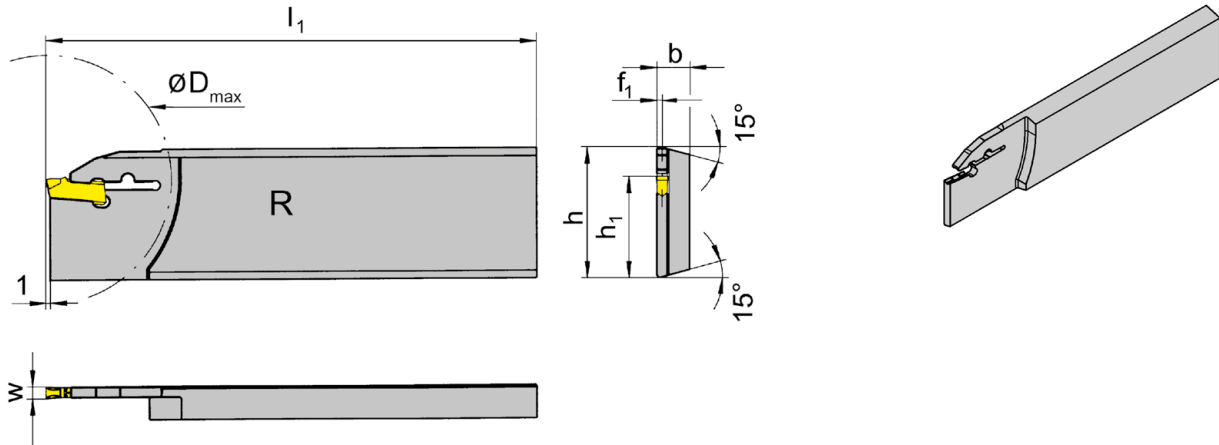
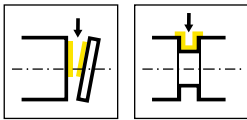

R = version à droite représentée
R = versione destra come in figura

L = version à gauche
L = versione sinistra a specchio

N° de commande Codice prodotto	h	b	l ₁	h ₁	f ₁	t _{max}	D _{max}	HWS
RH100.2608.31	26	7,9	110	21,4	0,75	21	42	100018
RH100.2608.32	26	7,9	110	21,4	0,95	25	50	100028
RH100.2608.33	26	7,9	110	21,4	1,15	25	50	100038
RH100.3208.31	32	7,9	112	24,8	0,75	25	50	100018
RH100.3208.32	32	7,9	112	24,8	0,95	34	68	100028
RH100.3208.33	32	7,9	112	24,8	1,15	34	68	100038
RH100.3208.34	32	7,9	112	24,8	1,55	34	68	100048
LH100.2608.31	26	7,9	110	21,4	0,75	21	42	100018
LH100.2608.32	26	7,9	110	21,4	0,95	25	50	100028
LH100.2608.33	26	7,9	110	21,4	1,15	25	50	100038
LH100.2608.34	26	7,9	110	21,4	1,55	25	50	100048
LH100.3208.31	32	7,9	112	24,8	0,75	25	50	100018
LH100.3208.32	32	7,9	112	24,8	0,95	34	68	100028
LH100.3208.33	32	7,9	112	24,8	1,15	34	68	100038
LH100.3208.34	32	7,9	112	24,8	1,55	34	68	100048

w voir plaquettes
w vd. inserti

La clé P39L n'est pas fournie avec le porte outils - à clé séparément!
La chiave P39L non viene fornita con la portainserto - bisogna ordinarla separatamente!

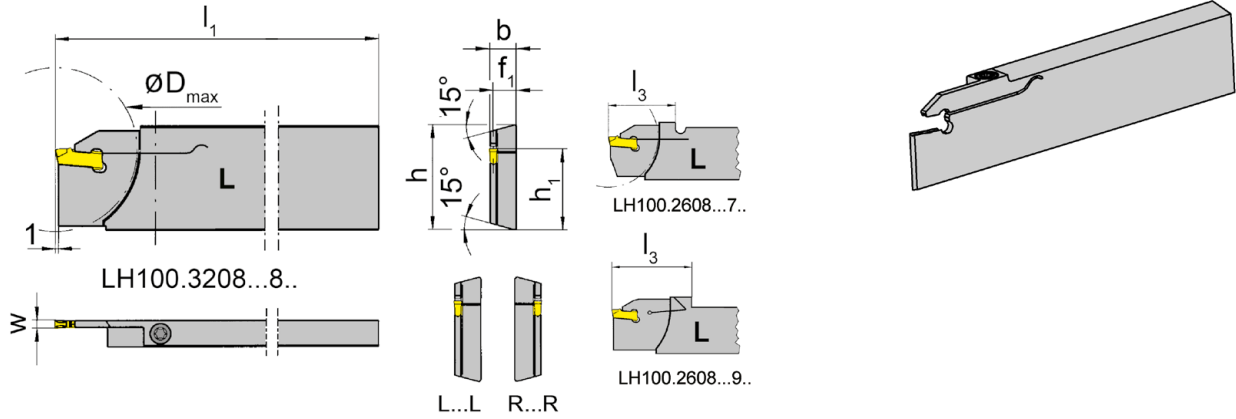
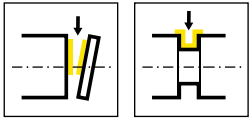

L = version à gauche représentée
L = versione sinistra come in figura

R = version à droite
R = versione destra a specchio

N° de commande Codice prodotto	h	b	l ₁	h ₁	f ₁	l ₃	t _{max}	D _{max}	HWS
RH100.2608.71R	26	7,9	110	21,4	7,15	33,8	25	50	100018
RH100.3208.71R	32	7,9	112	24,8	7,15	33,8	25	50	100018
RH100.2608.72R	26	7,9	110	21,4	6,95	33,8	25	50	100028
RH100.3208.72R	32	7,9	112	24,8	6,95	33,8	25	50	100028
RH100.2608.93R	26	8	115	21,4	6,85	40	25	50	100038
RH100.3208.93R	32	8	115	24,8	6,85	42	32,5	65	100038
LH100.2608.71L	26	7,9	110	21,4	7,15	33,8	25	50	100018
LH100.3208.71L	32	7,9	112	24,8	7,15	33,8	25	50	100018
LH100.2608.72L	26	7,9	110	21,4	6,95	33,8	25	50	100028
LH100.3208.72L	32	7,9	112	24,8	6,95	33,8	25	50	100028
LH100.2608.93L	26	8	115	21,4	6,85	40	25	50	100038
LH100.3208.93L	32	8	115	24,8	6,85	42	32,5	65	100038

w voir plaquettes
w vd. inserti

Pièces Détachées
Ricambi

Porte outils Portainsero	Vis de serrage Vite di serraggio	Tournevis TORX PLUS® Cacciavite TORX PLUS®
R/LH100...	4.15T15P	T15PQ
R/LH100...93R/L	030.0413.T15P	T15PQ

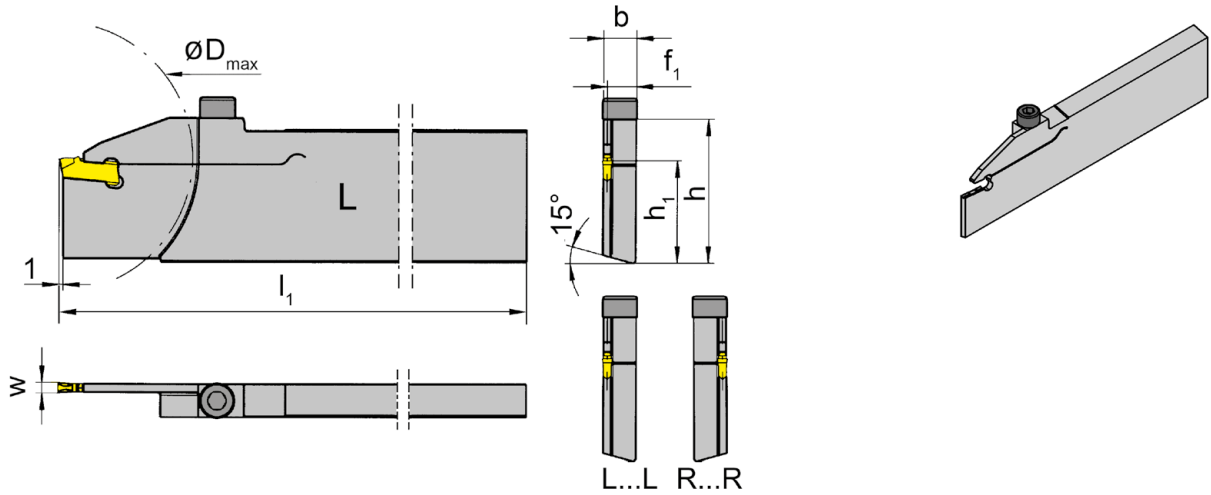
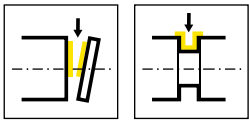

L = version à gauche représentée
L = versione sinistra come in figura

R = version à droite
R = versione destra a specchio

N° de commande Codice prodotto	h	b	l ₁	h ₁	f ₁	t _{max}	D _{max}	HWS
RH100.3280.73R	32	7,9	130	24,8	6,75	32,5	65	100038
RH100.3280.74R	32	7,9	130	24,8	6,35	32,5	65	100048
LH100.3280.73L	32	7,9	130	24,8	6,75	32,5	65	100038
LH100.3280.74L	32	7,9	130	24,8	6,35	32,5	65	100048

w voir plaquettes
w vd. inserti

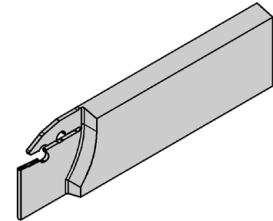
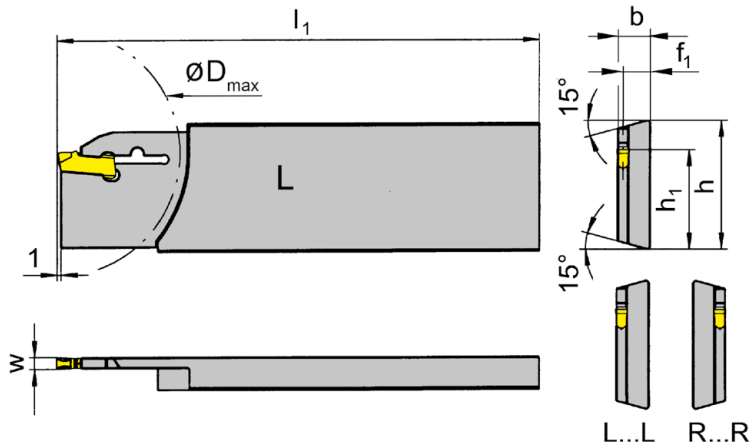
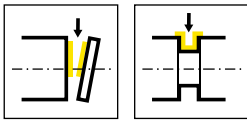

L = version à gauche représentée
L = versione sinistra come in figura

R = version à droite
R = versione destra a specchio

N° de commande Codice prodotto	h	b	l_1	h_1	f_1	t_{max}	D_{max}	HWS
RH100.2608.31R	26	7,9	110	21,4	7,15	21	42	100018
RH100.3208.31R	32	7,9	112	24,8	7,15	25	50	100018
RH100.2608.32R	26	7,9	110	21,4	6,95	25	50	100028
RH100.3208.32R	32	7,9	112	24,8	6,95	34	68	100028
RH100.2608.33R	26	7,9	110	21,4	6,75	25	50	100038
RH100.3208.33R	32	7,9	112	24,8	6,75	34	68	100038
RH100.2608.34R	26	7,9	110	21,4	6,35	25	50	100048
RH100.3208.34R	32	7,9	112	24,8	6,35	34	68	100048
LH100.2608.31L	26	7,9	110	21,4	7,15	21	42	100018
LH100.3208.31L	32	7,9	112	24,8	7,15	25	50	100018
LH100.2608.32L	26	7,9	110	21,4	6,95	25	50	100028
LH100.3208.32L	32	7,9	112	24,8	6,95	34	68	100028
LH100.2608.33L	26	7,9	110	21,4	6,75	25	50	100038
LH100.3208.33L	32	7,9	112	24,8	6,75	34	68	100038
LH100.2608.34L	26	7,9	110	21,4	6,35	25	50	100048
LH100.3208.34L	32	7,9	112	24,8	6,35	34	68	100048

w voir plaquettes
w vd. inserti

La clé P39L n'est pas fournie avec le porte outils - à cder séparément!
La chiave P39L non viene fornita con la portainserito - bisogna ordinarla separatamente!

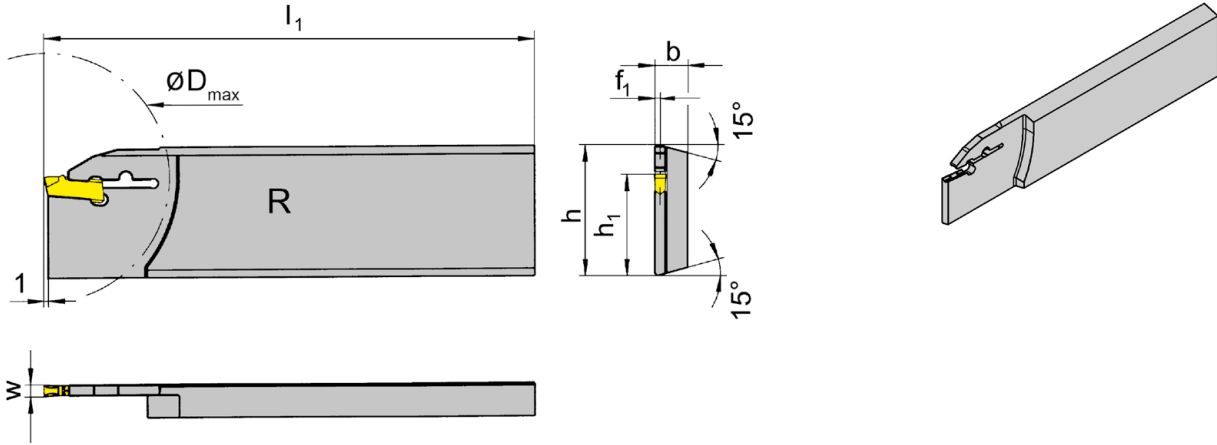
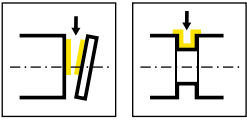

R = version à droite

R = versione destra

N° de commande Codice prodotto	h	b	l_1	h_1	f_1	t_{max}	D_{max}	HWS
RH100.3208.2.44	32	7,9	160	24,8	1,55	41	80	100048
RH100.3208.44	32	7,9	130	24,8	1,55	41	80	100048

w voir plaquettes

w vd. inserti

La clé P39L n'est pas fournie avec le porte outils - à cder séparément!

La chiave P39L non viene fornita con la portainsero - bisogna ordinarla separatamente!

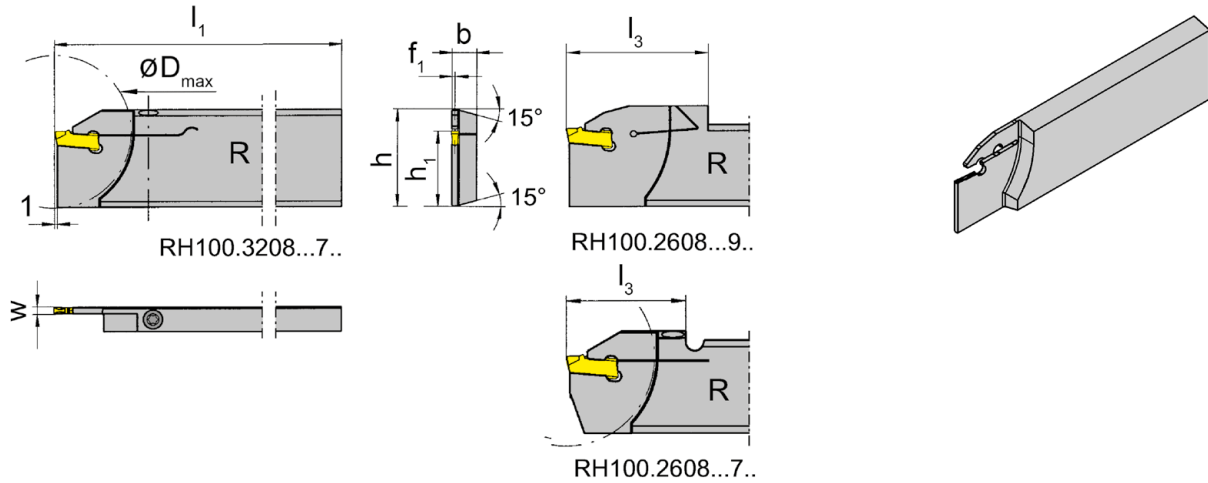
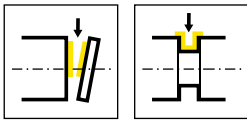

R = version à droite représentée
R = versione destra come in figura

L = version à gauche
L = versione sinistra a specchio

N° de commande Codice prodotto	h	b	l ₁	h ₁	f ₁	l ₃	t _{max}	D _{max}	HWS
RH100.2608.71	26	7,9	110	21,4	0,75	33,8	25	50	100018
RH100.3208.71	32	7,9	112	24,8	0,75	33,8	25	50	100018
RH100.2608.72	26	7,9	110	21,4	0,95	33,8	25	50	100028
RH100.3208.72	32	7,9	112	24,8	0,95	33,8	25	50	100028
RH100.2608.93	26	8	112	21,4	1,15	40	25	50	100038
RH100.3208.93	32	8	112	24,8	1,15	40	32,5	65	100038
LH100.2608.71	26	7,9	110	21,4	0,75	33,8	25	50	100018
LH100.3208.71	32	7,9	112	24,8	0,75	33,8	25	50	100018
LH100.2608.72	26	7,9	110	21,4	0,95	33,8	25	50	100028
LH100.3208.72	32	7,9	112	24,8	0,95	33,8	25	50	100028
LH100.2608.93	26	8	112	21,4	1,15	40	25	50	100038
LH100.3208.93	32	8	112	24,8	1,15	40	32,5	65	100038

w voir plaquettes
w vd. inserti

Pièces Détachées

Ricambi

Porte outils Portainsero	Vis de serrage Vite di serraggio	Tournevis TORX PLUS® Cacciavite TORX PLUS®
R/LH100...	4.15T15P	T15PQ
R/LH100...93	030.0413.T15P	T15PQ

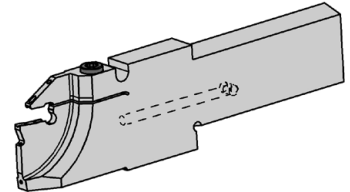
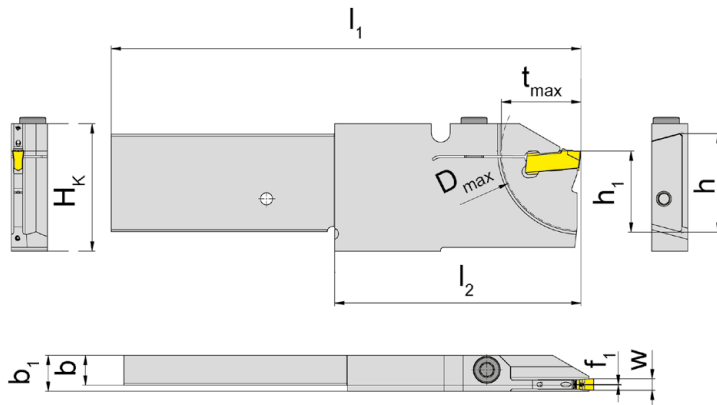
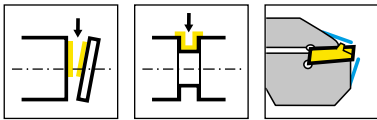

R = version à droite représentée
R = versione destra come in figura

L = version à gauche
L = versione sinistra a specchio

N° de commande Codice prodotto	H _k	h	b	l ₁	h ₁	f	t _{max}	l ₂	D _{max}	b ₁	HWS
RH100.2608.2.16.4.72.IK	33,6	26	7,9	124	21,4	0,2	16	65	32	9,5	100028
RH100.2608.2.16.4.72R.IK	33,6	26	7,9	124	21,4	6,4	16	65	32	9,5	100028
RH100.2608.2.21.4.73.IK	33,6	26	7,9	124	21,4	0,2	21	65	42	9,5	100038
RH100.2608.2.21.4.73R.IK	33,6	26	7,9	124	21,4	6,4	21	65	42	9,5	100038

pour machines DMG MORI (Multisprint)
per macchina TRAUB e INDEX

w voir plaquettes
w vd. inserti

Pièces Détachées

Ricambi

Porte outils Portainsero	Vis de serrage Vite di serraggio	Tournevis TORX PLUS® Cacciavite TORX PLUS®
RH100...	5.13T20P	T20PQ

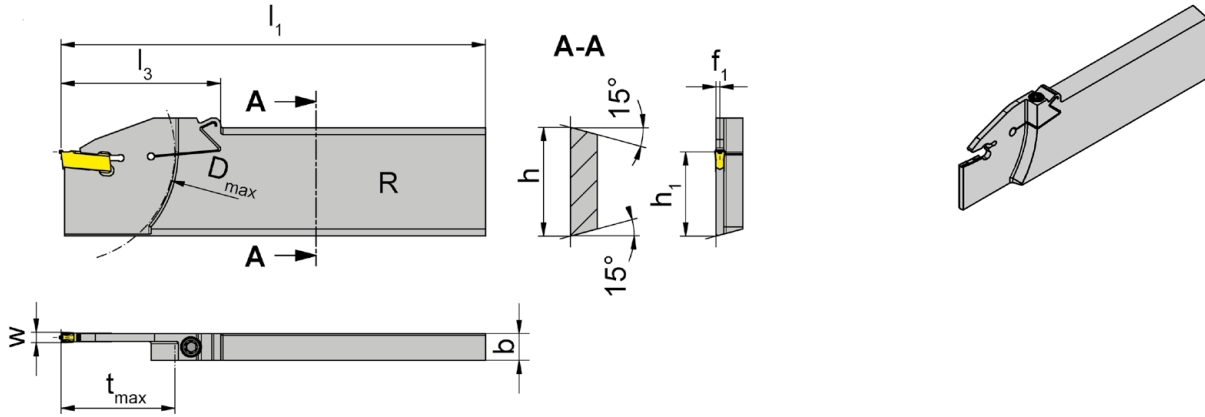
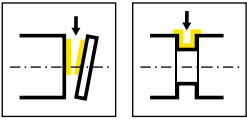

R = version à droite représentée
R = versione destra come in figura

L = version à gauche
L = versione sinistra a specchio

N° de commande Codice prodotto	h	b	l ₁	h ₁	f ₁	l ₃	t _{max}	D _{max}	Type de machine Tipo macchina	HWS
RH100.3208.83	32	8	125	24,8	1,15	47	33,5	65	TraubTNX65/42, IndexC65/	100038
LH100.3208.83	32	8	125	24,8	1,15	47	33,5	65	TraubTNX65/42, IndexC65/	100038
LH100.3208.15.83	32	8	150	24,8	1,15	47	33,5	65	TraubTNX65/42, IndexC65/	100038
LH100.3208.84	32	8	125	24,8	1,5	47	33,5	65	TraubTNX65/42, IndexC65/	100048

w voir plaquettes
w vd. inserti

Pièces Détachées
Ricambi

Porte outils Portainsero	Vis de serrage Vite di serraggio	Tournevis TORX PLUS® Cacciavite TORX PLUS®
R/LH100...	030.505P.0718	T15PQ
LH100.3208.15.83	030.505P.0718	T15PL

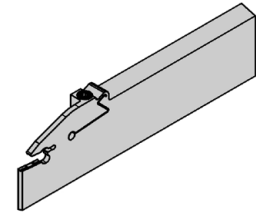
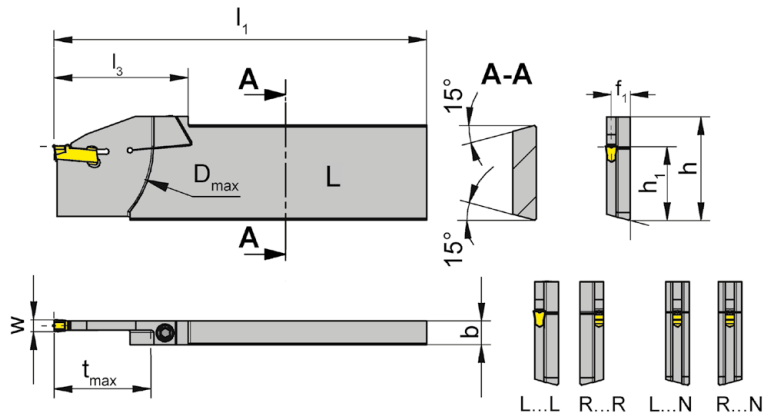
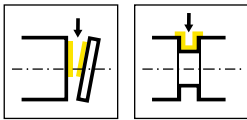

L = version à gauche représentée
L = versione sinistra come in figura

R = version à droite
R = versione destra a specchio

N° de commande Codice prodotto	h	b	l ₁	h ₁	f ₁	l ₃	t _{max}	D _{max}	Type de machine Tipo macchina	HWS
RH100.3208.83R	32	8	125	24,8	6,85	47	33,5	65	TraubTNX65/42, IndexC65	100038
RH100.3208.83N	32	8	125	24,8	4	47	33,5	65	TraubTNX65/42, IndexC65	100038
RH100.3208.84R	32	8	125	24,8	6,5	47	33,5	65	TraubTNX65/42, IndexC65	100048
RH100.3208.84N	32	8	134	24,8	4	54,5	41	80	TraubTNX80/65	100048
LH100.3208.83L	32	8	125	24,8	6,85	47	33,5	65	TraubTNX65/42, IndexC65	100038
LH100.3208.83N	32	8	125	24,8	4	47	33,5	65	TraubTNX65/42, IndexC65	100038
LH100.3208.84L	32	8	125	24,8	6,5	47	33,5	65	TraubTNX65/42, IndexC65	100048
LH100.3208.84N	32	8	134	24,8	4	54,5	41	80	TraubTNX80/65	100048

w voir plaquettes
w vd. inserti

Pièces Détachées

Ricambi

Porte outils Portainsero	Vis de serrage Vite di serraggio	Tournevis TORX PLUS® Cacciavite TORX PLUS®
R/LH100.3208....	030.505P.0718	T15PQ

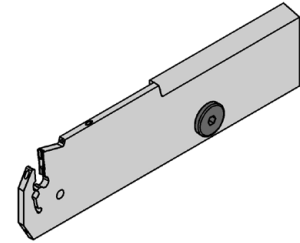
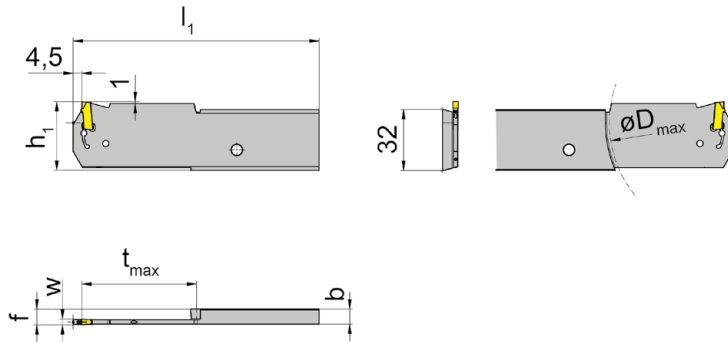
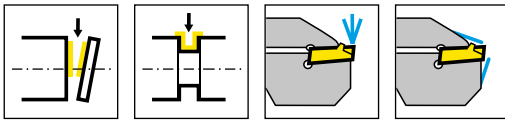

R = version à droite représentée
R = versione destra come in figura

L = version à gauche
L = versione sinistra a specchio

N° de commande Codice prodotto	b	l ₁	h ₁	f	t _{max}	D _{max}	HWS
RH100.3208.Y.60.3.83.IK*	7,9	128,5	36	8,25	60	120	100039 • 100038
RH100.3208.Y.60.3.84.IK*	7,9	128,5	36	8,25	60	120	100049 • 100048
RH100.3208.Y.60.4.83.IK	7,9	128,5	36	8,25	60	120	100038
RH100.3208.Y.60.4.84.IK	7,9	128,5	36	8,25	60	120	100048
LH100.3208.Y.60.3.83.IK*	7,9	128,5	36	8,25	60	120	100039 • 100038
LH100.3208.Y.60.3.84.IK*	7,9	128,5	36	8,25	60	120	100049 • 100048
LH100.3208.Y.60.4.83.IK	7,9	128,5	36	8,25	60	120	100038
LH100.3208.Y.60.4.84.IK	7,9	128,5	36	8,25	60	120	100048

* = Arrosage central sur la plaquette

* = Adduzione del lubrorefrigerante attraverso l'inserto

w voir plaquettes
w vd. inserti

La clé **P101.02** n'est pas fournie avec le fraise - à cder séparément!
La chiave P101.02 non viene fornita con fresa - bisogna ordinarla separatamente!

Pièces Détachées

Ricambi

Porte outils Portainsero	Bouchon de réfrigérant Tappo del refrigerante
R/LH100...	020.IK01.5732

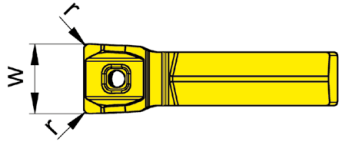
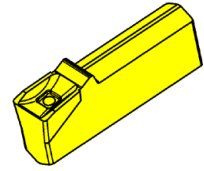
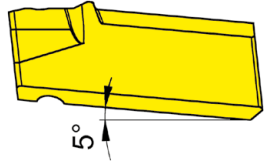
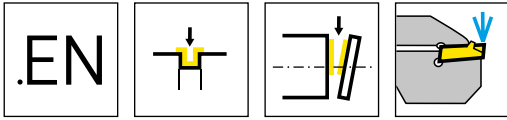

Nuance
Leghe

▲ en stock
a stock

Δ 4 semaines
4 settimane

N° de commande Codice prodotto	w	r	HIS	Nuance Leghe		
				AS45	EG55	HP65
S100.0250.EN2.IK	2,5	0,2	100029	▲	Δ	▲
S100.0300.EN2.IK	3	0,2	100039	▲	▲	▲
S100.0400.EN3.IK	4	0,3	100049	▲	▲	▲
P	●	●	●	●	●	●
M	●	○	●	●	○	●
K	●	○	●	●	○	●
N	○	-	○	○	-	○
S	●	-	●	●	-	●
H	-	-	-	-	-	-

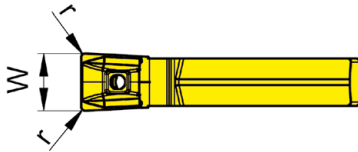
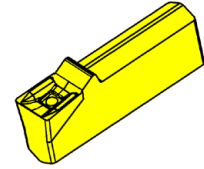
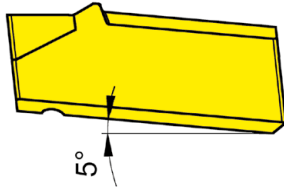
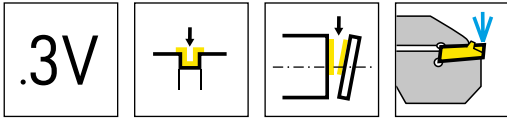

Nuance
Leghe

▲ en stock
a stock

Δ 4 semaines
4 settimane

N° de commande Codice prodotto	w	r	HIS	Nuance	
				HP65	IG35
S100.0250.3V2.IK	2,5	0,2	100029	▲	▲
S100.0300.3V2.IK	3	0,2	100039	▲	▲
				P ● -	
				M ● ●	
				K ● -	
				N ○ -	
				S ● ●	
				H - -	

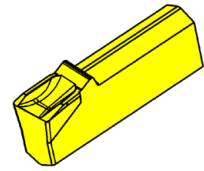
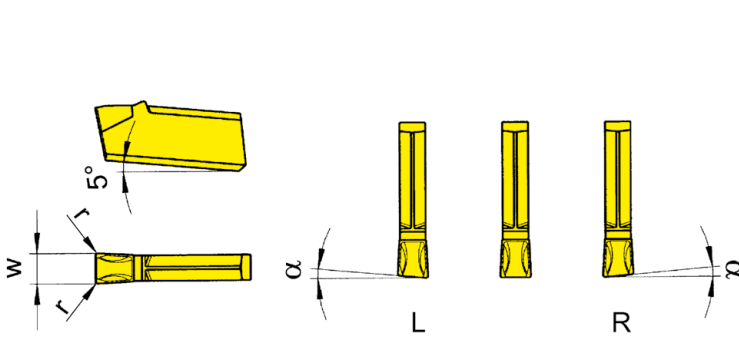
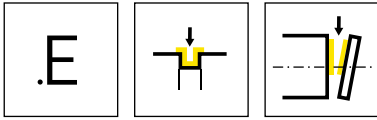

R = version à droite
R = versione destra

L = version à gauche
L = versione sinistra

▲ en stock
a stock

Δ 4 semaines
4 settimane

Nuance
Leghe

N° de commande Codice prodotto	w	r	α	HIS	ALX2	ALX3	AS63	AS66	TC92	TC93	TF42	TF43	TF45	TF46	TI22
RS100.0520.E2	2	0,2	5°	100018					Δ			▲	▲	Δ	
RS100.0525.E2	2,5	0,2	5°	100028					Δ	▲		▲	▲	Δ	Δ
RS100.0530.E2	3	0,2	5°	100038		▲			Δ	Δ	▲	▲	▲	▲	▲
RS100.0540.E2	4	0,2	5°	100048		Δ			Δ	Δ		▲	▲	Δ	Δ
LS100.0520.E2	2	0,2	5°	100018					Δ	Δ		Δ	▲	Δ	
LS100.0525.E2	2,5	0,2	5°	100028					Δ	Δ		Δ	Δ	Δ	Δ
LS100.0530.E2	3	0,2	5°	100038		▲			▲	Δ	Δ	▲	▲	▲	Δ
LS100.0540.E2	4	0,2	5°	100048		Δ			Δ	Δ		▲	▲	Δ	
S100.0200.E2	2	0,2	0°	100018		▲				Δ		▲	▲	▲	▲
S100.0250.E2	2,5	0,2	0°	100028					Δ			▲	▲	▲	▲
S100.0300.E2	3	0,2	0°	100038	▲	▲	▲	▲	▲	▲	▲	▲	▲	▲	▲
S100.0400.E3	4	0,3	0°	100048		▲				▲		▲	▲	▲	▲
S100.0500.E3	5	0,3	0°	100058				Δ	Δ	▲		▲	▲	▲	Δ
P	●	●	●	●	●	●	●	●	●	●	●	●	●	●	●
M	-	-	-	o	-	-	-	o	-	-	-	-	●	o	-
K	-	-	-	●	-	-	-	-	-	-	-	-	●	●	-
N	-	-	-	●	-	-	-	-	-	-	-	-	●	●	-
S	-	-	-	o	-	-	-	-	-	-	-	-	●	o	-
H	-	-	-	-	-	-	-	-	-	-	-	-	-	-	-

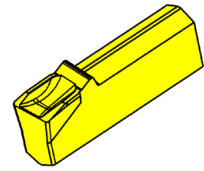
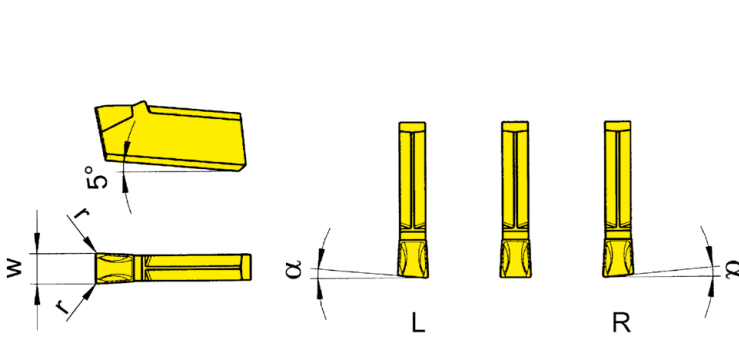
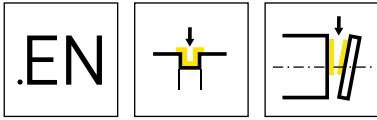

R = version à droite
R = versione destra

L = version à gauche
L = versione sinistra

▲ en stock
a stock

Δ 4 semaines
4 settimane

Nuance
Leghe

N° de commande Codice prodotto	w	r	α	HIS	ALX3	ALX5	AS62	AS63	AS66	AS6G	TF45	TH35
RS100.0530.EN2	3	0,2	5°	100038			▲		▲			
RS100.0540.EN2	4	0,2	5°	100048	▲							
LS100.0540.EN2	4	0,2	5°	100048	▲							
LS100.0480.EN8	8	0,8	4°	100088					▲			
S100.0200.EN2	2	0,2	0°	100018	▲	Δ				▲		Δ
S100.0220.EN2	2,2	0,2	0°	100018						▲		
S100.0250.EN2	2,5	0,2	0°	100028						▲		
S100.0300.EN2	3	0,2	0°	100038	▲	Δ		▲	▲	▲	Δ	
S100.0400.EN3	4	0,3	0°	100048	▲			▲		▲		
S100.0500.EN3	5	0,3	0°	100058	▲					▲		
S100.0600.EN6	6	0,6	0°	100068						▲		
S100.0800.EN8	8	0,8	0°	100088						▲		
S100.1000.EN8	10	0,8	0°	100108						▲		
S100.1200.EN8	12	0,8	0°	100128						▲		
S100.1600.EN8	16	0,8	0°	100168						▲		
P	●	●	●	●	●	●	●	●	●	●	●	●
M	-	●	-	-	○	●	●	●	●	●	●	●
K	-	●	-	-	●	●	●	●	●	●	●	●
N	-	●	-	-	●	●	●	●	●	●	●	●
S	-	●	-	-	○	●	●	●	●	●	●	●
H	-	-	-	-	-	-	-	-	-	-	-	-

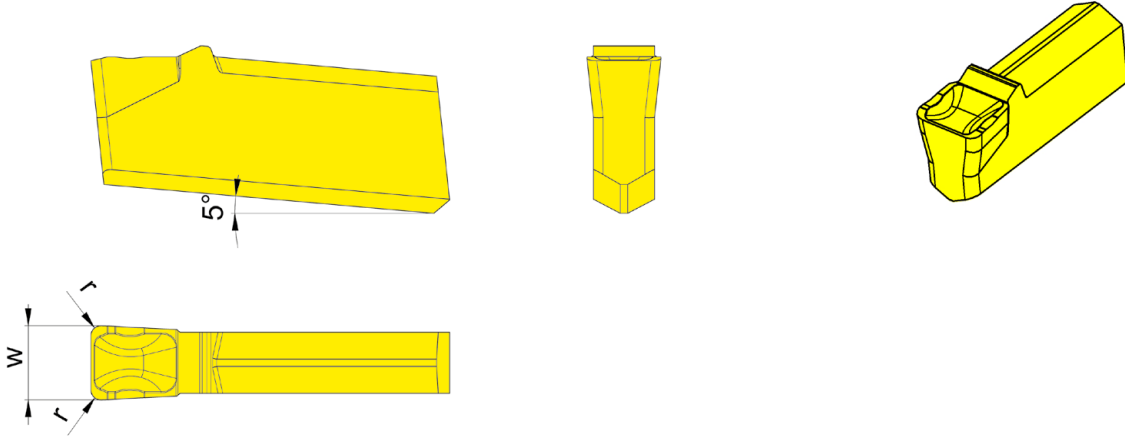
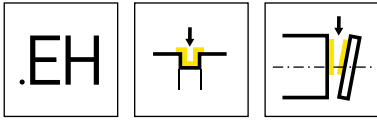

Nuance
Leghe

▲ en stock
a stock

Δ 4 semaines
4 settimane

N° de commande Codice prodotto	w	r	HIS	IG6G
S100.0300.EH4	3	0,4	100038	▲
S100.0400.EH6	4	0,6	100048	▲
				P ●
				M ○
				K ○
				N -
				S -
				H -

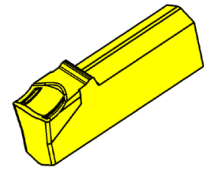
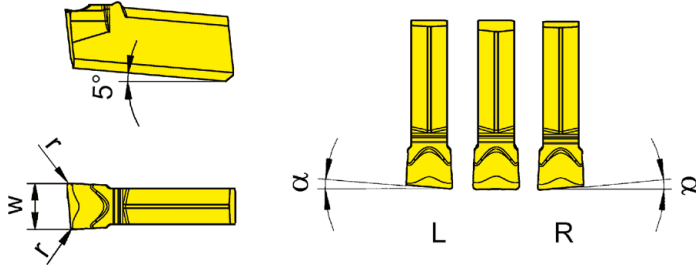
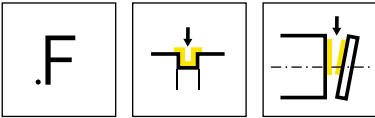

R = version à droite représentée
R = versione destra come in figura

L = version à gauche
L = versione sinistra a specchio

▲ en stock
a stock

△ 4 semaines
4 settimane

Nuance
Leghe

N° de commande Codice prodotto	w	r	α	HIS		TC92	TC93	TF42	TF43	TF45	TF46	TI22
RS100.0520.F2	2	0,2	5°	100018		△	△		△	▲		△
RS100.0525.F2	2,5	0,2	5°	100028		△	△		△	▲	△	△
RS100.0530.F2	3	0,2	5°	100038		△	△		▲	▲	▲	△
RS100.0540.F2	4	0,2	5°	100048		△	△			▲	△	△
LS100.0520.F2	2	0,2	5°	100018		△	△		△		△	△
LS100.0525.F2	2,5	0,2	5°	100028		△	△		△	▲	△	△
LS100.0530.F2	3	0,2	5°	100038		△			△	▲	▲	▲
LS100.0540.F2	4	0,2	5°	100048		△	△		△	▲	△	△
S100.0200.F2	2	0,2	-	100018		▲	△		▲	▲	▲	▲
S100.0250.F2	2,5	0,2	0°	100028		△	△			▲	△	▲
S100.0300.F2	3	0,2	0°	100038			▲	△	▲	▲	▲	▲
S100.0400.F3	4	0,3	0°	100048		△	▲		▲	▲	▲	▲
S100.0500.F3	5	0,3	0°	100058		△			△	▲	△	▲
P						●	●	●	●	●	●	●
M						-	-	-	-	●	○	-
K						-	-	-	-	●	●	-
N						-	-	-	-	●	●	-
S						-	-	-	-	●	○	-
H						-	-	-	-	-	-	-

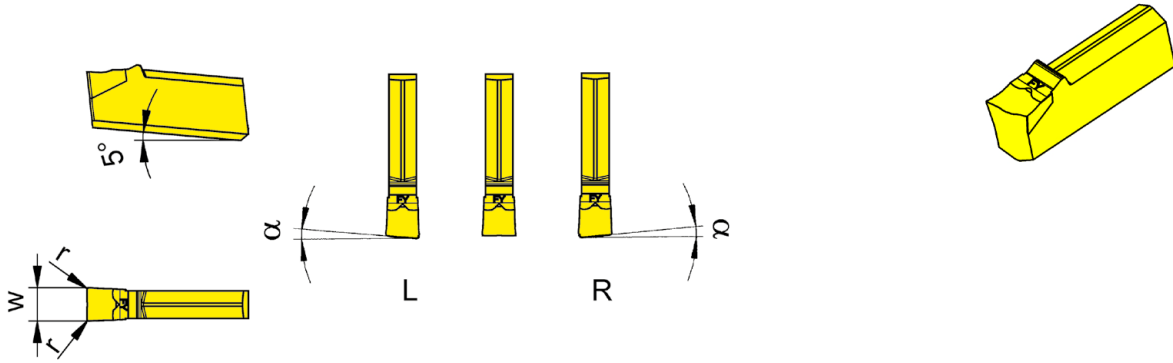
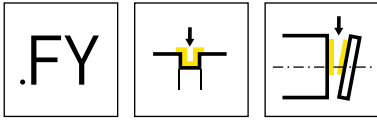

R = version à droite
R = versione destra

L = version à gauche
L = versione sinistra

Nuance
Leghe
▲ en stock
a stock
Δ 4 semaines
4 settimane

N° de commande Codice prodotto	w	r	α	HIS	Nuance Leghe				
					AS45	HP65	IG35	PH35	TI25
RS100.1520.FY0	2	0	15°	100018	▲		▲		
RS100.1530.FY0	3	-	15°	100038	▲		▲		
LS100.1520.FY0	2	0	15°	100018	▲		▲		
LS100.1530.FY0	3	-	15°	100038	▲		▲		
S100.0200.FY2	2	0,2	-	100018	Δ	▲	▲	Δ	▲
S100.0220.FY2	2,2	0,2	0°	100018			▲		▲
S100.0250.FY2	2,5	0,2	0°	100028	Δ	▲	▲		▲
S100.0300.FY2	3	0,2	0°	100038	Δ	▲	▲		▲
S100.0400.FY3	4	0,3	0°	100048		▲	▲		▲
P					●	●	-	○	●
M					●	●	●	○	●
K					●	●	-	●	●
N					○	○	-	-	●
S					●	●	●	-	●
H					-	-	-	-	-

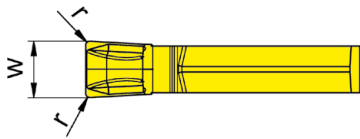
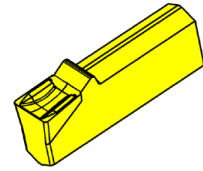
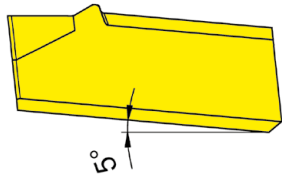
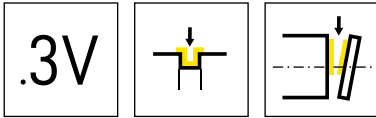

Nuance
Leghe

▲ en stock
a stock

Δ 4 semaines
4 settimane

N° de commande Codice prodotto	w	r	HIS					
				AS45	HP35	HP65	IG35	PH35
S100.0200.3V2	2	0,2	100018	▲	Δ	▲	▲	Δ
S100.0250.3V2	2,5	0,2	100028	▲		▲	▲	
S100.0300.3V2	3	0,2	100038	▲		▲	▲	
S100.0400.3V3	4	0,3	100048	▲		▲	▲	
P	●	○	●	-	○			
M	●	●	●	●	○			
K	●	○	●	-	●			
N	○	-	○	-	-			
S	●	○	●	●	-			
H	-	-	-	-	-			

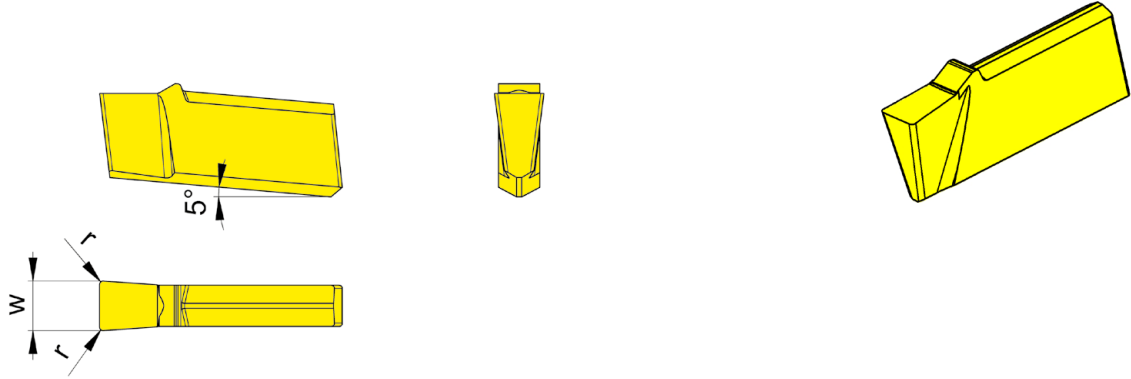
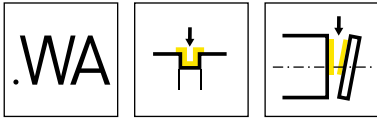

Nuance
Leghe

▲ en stock
a stock

Δ 4 semaines
4 settimane

N° de commande Codice prodotto	w	r	HIS	K10	DD26
S100.0200.WA2	2	0,2	100018	▲	▲
S100.0300.WA2	3	0,2	100038	▲	▲
				P ●	-
				M ○	-
				K ●	-
				N ●	●
				S ○	○
				H -	-

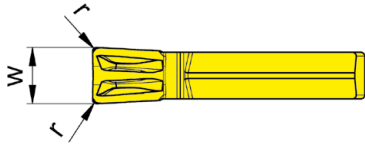
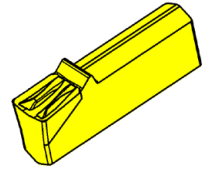
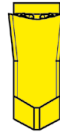
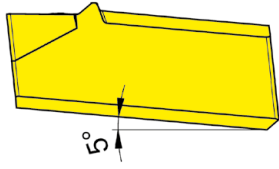
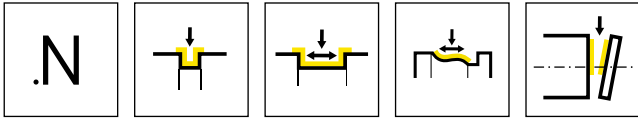

Nuance
Leghe

▲ en stock
a stock

Δ 4 semaines
4 settimane

N° de commande Codice prodotto	w	r	HIS	AS45	HP65
S100.0300.N2	3	0,2	100038	▲	▲
S100.0400.N3	4	0,3	100048	▲	▲
P	●	●			
M	●	●			
K	●	●			
N	o	o			
S	●	●			
H	-	-			

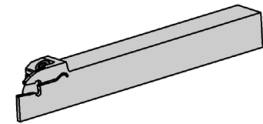
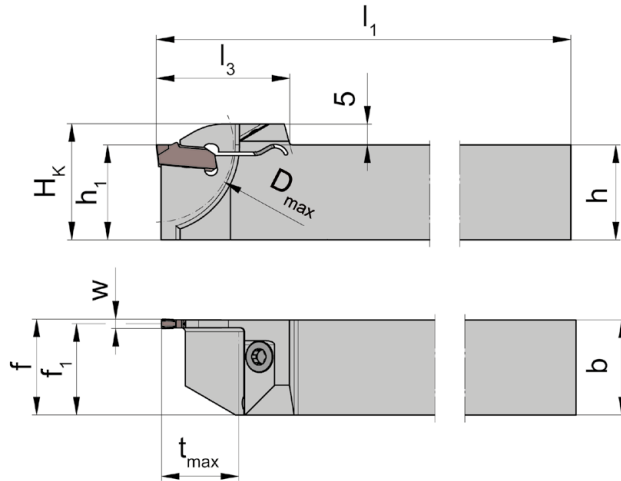
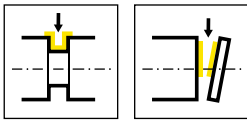

L = version à gauche représentée
L = versione sinistra come in figura

R = version à droite
R = versione destra a specchio

N° de commande Codice prodotto	h	b	l_1	l_3	h_1	f_1	f	t_{max}	H_k	D_{max}	HWS
RH101.1010.1.12	10	10	125	22,5	10	9,53	$f_1+w/2$	13	13,5	26	10112
RH101.1212.1.12	12	12	125	22,5	12	11,53	$f_1+w/2$	13	15,5	26	10112
RH101.1616.1.12	16	16	125	22,5	16	15,53	$f_1+w/2$	13	19,5	26	10112
RH101.1010.1.16	10	10	125	22,5	10	9,35	$f_1+w/2$	13	13,5	26	10116
RH101.1212.1.16	12	12	125	22,5	12	11,35	$f_1+w/2$	13	15,5	26	10116
RH101.1616.1.16	16	16	125	22,5	16	15,35	$f_1+w/2$	13	19,5	26	10116
LH101.1010.1.12	10	10	125	22,5	10	9,53	$f_1+w/2$	13	13,5	26	10112
LH101.1212.1.12	12	12	125	22,5	12	11,53	$f_1+w/2$	13	15,5	26	10112
LH101.1616.1.12	16	16	125	22,5	16	15,53	$f_1+w/2$	13	19,5	26	10112
LH101.1010.1.16	10	10	125	22,5	10	9,35	$f_1+w/2$	13	13,5	26	10116
LH101.1212.1.16	12	12	125	22,5	12	11,35	$f_1+w/2$	13	15,5	26	10116
LH101.1616.1.16	16	16	125	22,5	16	15,35	$f_1+w/2$	13	19,5	26	10116

w voir plaquettes
w vd. inserti

Pièces Détachées

Ricambi

Porte outils Portainsero	Vis de serrage Vite di serraggio	Tournevis TORX PLUS® Cacciavite TORX PLUS®
R/LH101...	3.5.12T10EP	T10PL

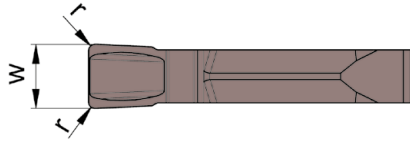
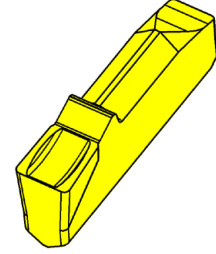
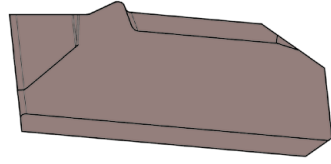
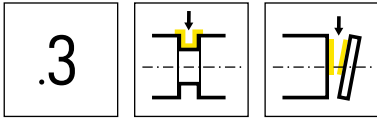

Nuance
Leghe
▲ en stock
a stock
Δ 4 semaines
4 settimane

N° de commande Codice prodotto	w	r	HIS	AS45	IG35
S101.0120.315	1,2	0,15	10112	▲	▲
S101.0160.315	1,6	0,15	10116	▲	▲
				P ●	-
				M ●	●
				K ●	-
				N ○	-
				S ●	●
				H -	-