

223



Porte outils et plaquettes

avec brise copeaux
Largeur de gorge 2 - 3 mm
Profondeur de gorge jusqu'à 25 mm

Portainserito e inserti

con formatruciolo
Larghezza della gola 2 - 3 mm
Profondità della gola fino a 25 mm

U

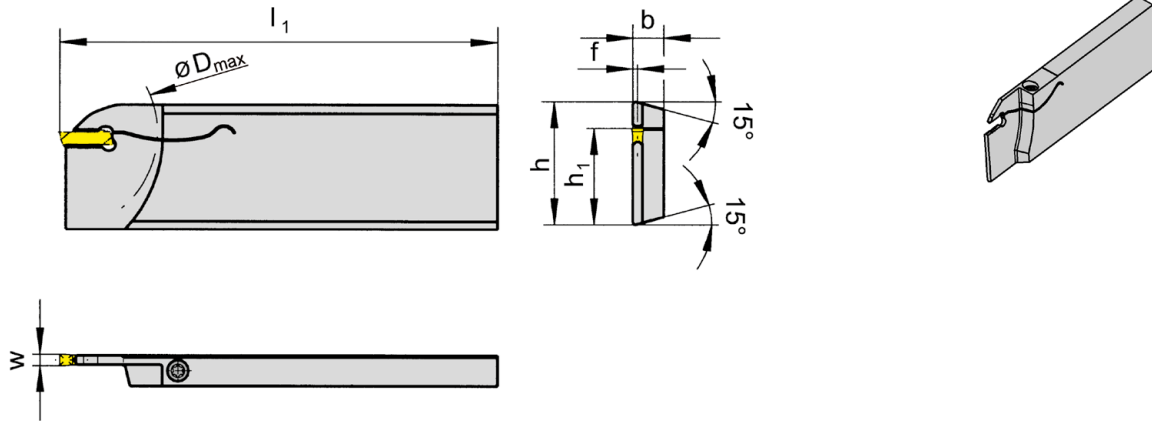
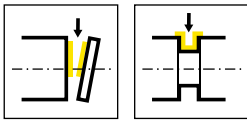

R = version à droite représentée
R = versione destra come in figura

L = version à gauche
L = versione sinistra a specchio

N° de commande Codice prodotto	h	b	l ₁	h ₁	f	D _{max}	HWS
RH223.2608.01	26	7,9	110	21,4	0,8	50	12301 • 22301
RH223.3208.01	32	7,9	110	24,8	0,8	50	12301 • 22301
RH223.2608.02	26	7,9	110	21,4	0,95	50	22302
RH223.3208.02	32	7,9	110	24,8	0,95	50	22302
RH223.2608.03	26	7,9	110	21,4	1,2	50	12303 • 22303
LH223.2608.01	26	7,9	110	21,4	0,8	50	12301 • 22301
LH223.3208.01	32	7,9	110	24,8	0,8	50	12301 • 22301
LH223.2608.02	26	7,9	110	21,4	0,95	50	22302
LH223.3208.02	32	7,9	110	24,8	0,95	50	22302
LH223.2608.03	26	7,9	110	21,4	1,2	50	12303 • 22303
LH223.3208.03	32	7,9	110	24,8	1,2	50	12303 • 22303

w voir plaquettes amovibles
w vd. inserti

Tronçonnage de barre/barre
Troncatura di barre piene/tubi
S223

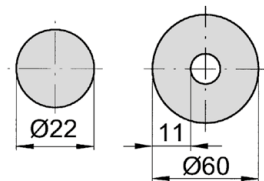

Tronçonnage de barre
Troncatura di barre piene
S123

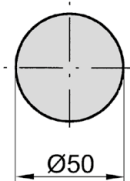

Pièces Détachées

Ricambi

Porte outils Portainsero	Vis de serrage Vite di serraggio	Tournevis TORX PLUS® Cacciavite TORX PLUS®
R/LH223...	4.15T15P	T15PL

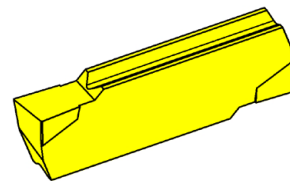
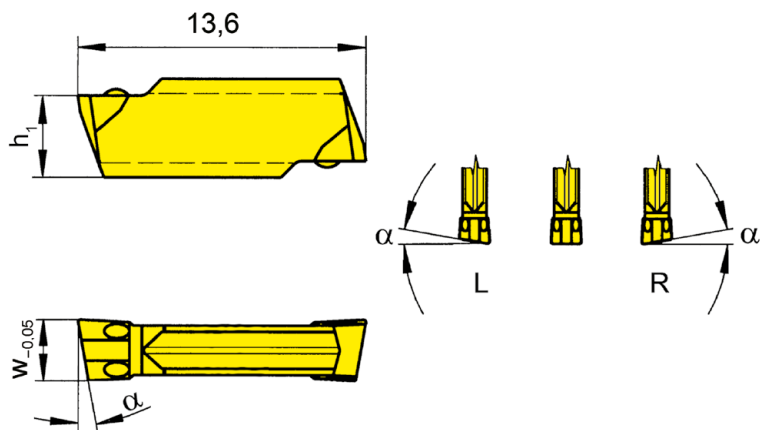
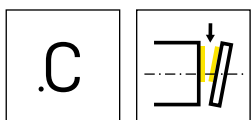

R = version à droite représentée
R = versione destra come in figura

L = version à gauche
L = versione sinistra a specchio

▲ en stock
a stock

Nuance
Leghe
Δ 4 semaines
4 settimane

N° de commande Codice prodotto	w	α	h ₁	HIS	Nuance Leghe			
					EG55	TF45	TI25	TN35
RS223.0420.C0	2	4°	3,65	22301	Δ	Δ	▲	▲
RS223.0820.C0	2	8°	3,65	22301	▲	▲	▲	▲
RS223.1520.C0	2	15°	3,65	22301	▲	▲	▲	▲
RS223.0425.C0	2,5	4°	3,75	22302	Δ	Δ	▲	
RS223.0825.C0	2,5	8°	3,75	22302	▲	▲	▲	▲
RS223.0430.C0	3	4°	3,95	22303	Δ	Δ	Δ	Δ
RS223.0830.C0	3	8°	3,95	22303	Δ	▲	▲	▲
LS223.0420.C0	2	4°	3,65	22301	Δ	Δ		▲
LS223.0820.C0	2	8°	3,65	22301	Δ		▲	▲
LS223.1520.C0	2	15°	3,65	22301	Δ	Δ	▲	▲
LS223.0425.C0	2,5	4°	3,75	22302	Δ	Δ	Δ	Δ
LS223.0825.C0	2,5	8°	3,75	22302	Δ	Δ	Δ	
LS223.0430.C0	3	4°	3,95	22303	Δ	Δ	Δ	Δ
LS223.0830.C0	3	8°	3,95	22303	Δ	Δ	Δ	Δ
S223.0020.C0	2	0°	3,65	22301	▲	▲	▲	▲
S223.0025.C0	2,5	0°	3,75	22302	Δ	Δ	▲	Δ
S223.0030.C0	3	0°	3,95	22303	Δ	Δ	▲	▲
P					●	●	●	●
M					○	●	●	●
K					○	●	●	●
N					-	●	●	●
S					-	●	●	●
H					-	-	-	-



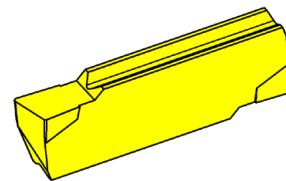
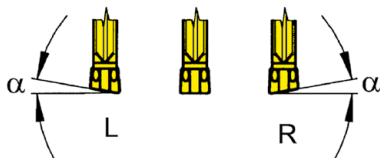
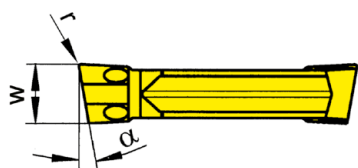
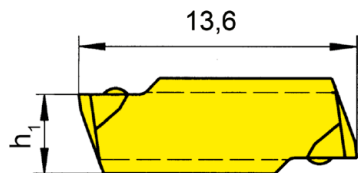
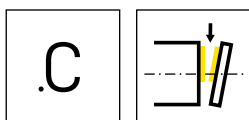

R = version à droite représentée
R = versione destra come in figura

L = version à gauche
L = versione sinistra a specchio

▲ en stock
a stock

Nuance
Leghe
Δ 4 semaines
4 settimane

N° de commande Codice prodotto	w	r	α	h ₁	HIS	EG55	TF45	TI25	TN35
RS223.0420.C1	2	0,15	4°	3,65	22301	Δ	Δ	Δ	▲
RS223.0820.C1	2	0,15	8°	3,65	22301	Δ	▲	▲	▲
RS223.1520.C1	2	0,15	15°	3,65	22301	Δ	▲	Δ	▲
RS223.0425.C1	2,5	0,15	4°	3,75	22302	Δ	Δ	Δ	Δ
RS223.0825.C1	2,5	0,15	8°	3,75	22302	Δ	Δ	▲	Δ
RS223.0430.C1	3	0,15	4°	3,95	22303	Δ	Δ		Δ
RS223.0830.C1	3	0,15	8°	3,95	22303	Δ	▲	Δ	
LS223.0420.C1	2	0,15	4°	3,65	22301	Δ	Δ	Δ	▲
LS223.0820.C1	2	0,15	8°	3,65	22301	Δ		Δ	Δ
LS223.1520.C1	2	0,15	15°	3,65	22301	Δ		Δ	Δ
LS223.0425.C1	2,5	0,15	4°	3,75	22302	Δ	Δ	Δ	Δ
LS223.0825.C1	2,5	0,15	8°	3,75	22302	Δ		Δ	Δ
LS223.0430.C1	3	0,15	4°	3,95	22303	Δ	Δ	Δ	Δ
LS223.0830.C1	3	0,15	8°	3,95	22303	Δ	Δ	Δ	Δ
S223.0020.C1	2	0,15	0°	3,65	22301	Δ	▲	▲	▲
S223.0025.C1	2,5	0,15	0°	3,75	22302	Δ	Δ	▲	Δ
S223.0030.C1	3	0,15	0°	3,95	22303	Δ	▲	▲	▲

P	●	●	●	●
M	○	●	●	●
K	○	●	●	●
N	-	●	●	●
S	-	●	●	●
H	-	-	-	-

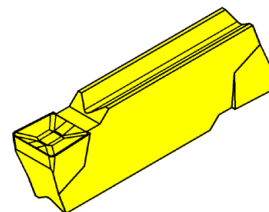
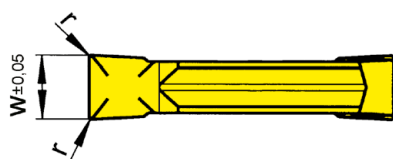
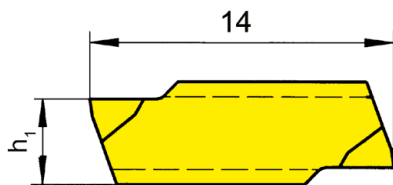
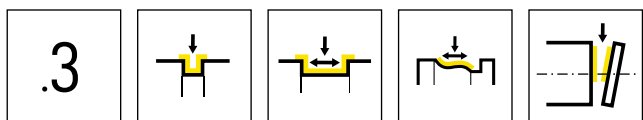

Nuance
Leghe

▲ en stock
a stock

Δ 4 semaines
4 settimane

N° de commande Codice prodotto	w	r	h ₁	HIS		MG12	EG55	H54	TI25	TN35
S223.0200.32	2	0,2	3,65	22301		▲	▲	▲	▲	▲
S223.0250.32	2,5	0,2	3,75	22302		▲	▲	▲	▲	▲
S223.0300.32	3	0,2	3,95	22303		▲	▲	▲	▲	▲
					P	o	•	•	•	•
					M	-	o	•	•	•
					K	-	o	-	•	•
					N	-	-	-	•	•
					S	-	-	-	•	•
					H	-	-	-	-	-



Porte outils
Portainsero
H224

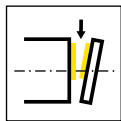

Page/Pag.
644-650

Plaque amovible
Inserto
S224

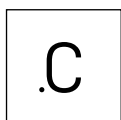

Page/Pag.
651-652

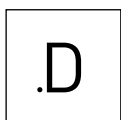

Page/Pag.
653

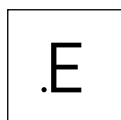

Page/Pag.
654

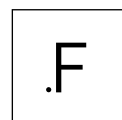

Page/Pag.
655

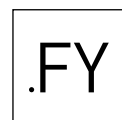

Page/Pag.
656



Page/Pag.
657

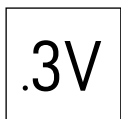

Page/Pag.
658

Informations techniques
Informazioni tecniche

Page/Pag.
713