

100



Porte outils et plaquettes

Profondeur de gorge 2 - 6 mm
Profondeur de gorge jusqu'à 55 mm

Portainsero e inserti

Profondità della gola 2 - 6 mm
Profondità della gola fino a 55 mm

U

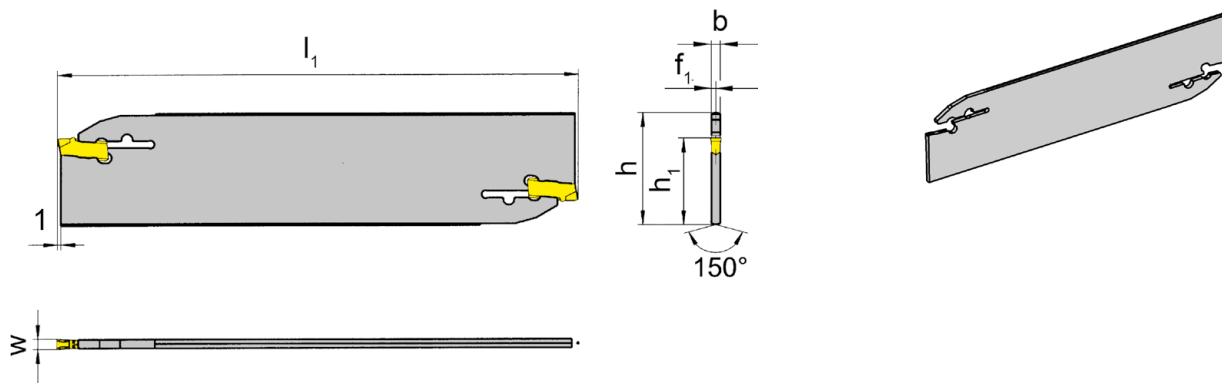
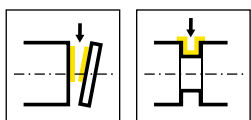

N° de commande Codice prodotto	h	b	l ₁	h ₁	f ₁	t _{max}	HWS
H100.2601.01	26	1,5	110	21,4	0,75	25	100018
H100.2602.02	26	1,9	110	21,4	0,95	37,5	100028
H100.2603.03	26	2,3	110	21,4	1,15	37,5	100038
H100.2604.04	26	3,1	110	21,8	1,65	40	100048
H100.3201.01	32	1,5	150	24,8	0,75	25	100018
H100.3202.02	32	1,9	150	24,8	0,95	50	100028
H100.3203.03	32	2,3	150	24,8	1,15	50	100038
H100.3204.04	32	3,1	160	24,8	1,65	55	100048
H100.3205.05	32	3,9	160	24,8	2	55	100058

w voir plaquettes
w vd. inserti

La clé P39L n'est pas fournie avec le porte outils - à cder séparément!
La chiave P39L non viene fornita con la portainsero - bisogna ordinarla separatamente!

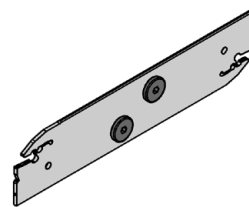
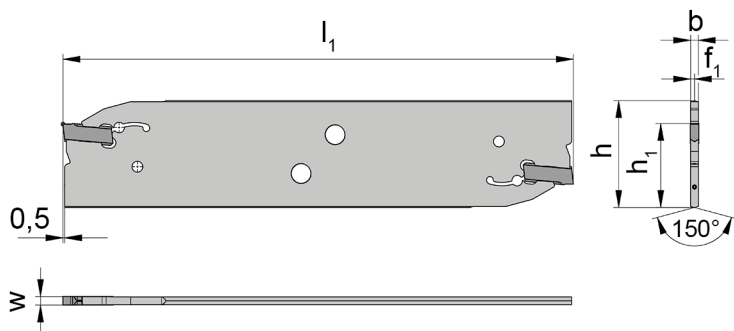
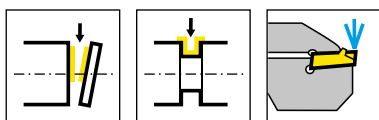

N° de commande Codice prodotto	h	b	l ₁	h ₁	f ₁	t _{max}	HWS
H100.2602.8.02.IK	26	1,9	110	21,4	0,95	35	100029 • 100028
H100.2603.8.03.IK	26	2,3	110	21,4	1,15	35	100039 • 100038
H100.2604.8.04.IK	26	3,1	110	21,4	1,55	35	100049 • 100048
H100.3202.8.02.IK	32	1,9	150	24,8	0,95	55	100029 • 100028
H100.3203.8.03.IK	32	2,3	150	24,8	1,15	60	100039 • 100038
H100.3204.8.04.IK	32	3,1	150	24,8	1,55	60	100049 • 100048

La clé P101.02 n'est pas fournie avec le fraise - à cder séparément!
La chiave P101.02 non viene fornita con fresa - bisogna ordinarla separatamente!

U

Pièces Détachées

Ricambi

Porte outils Portainsero	
H100...	020.IK01.5732

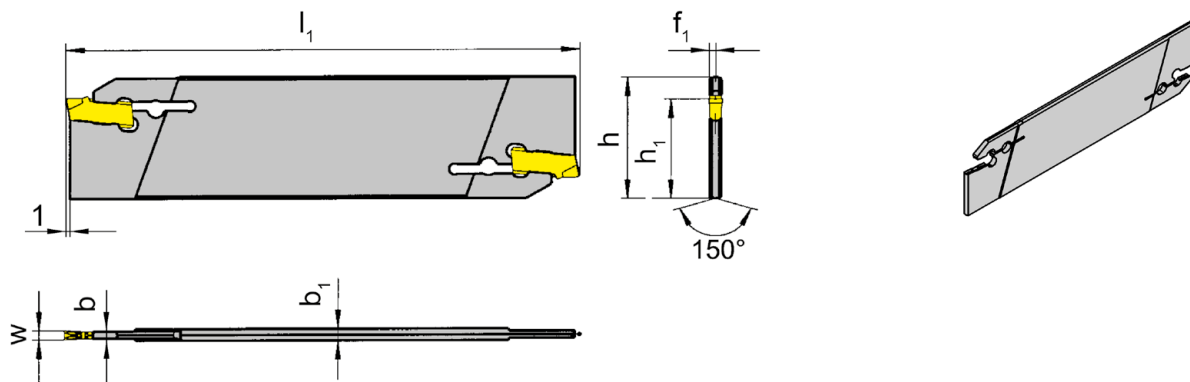
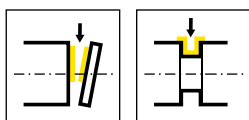

N° de commande Codice prodotto	h	b	l ₁	h ₁	f ₁	t _{max}	b ₁	HWS
H100.2603.01	26	1,5	110	21,4	1,15	21	2,3	100018
H100.2603.02	26	1,9	110	21,4	1,15	21	2,3	100028
H100.3203.01	32	1,5	150	24,8	1,15	25	2,3	100018
H100.3203.02	32	1,9	150	24,8	1,15	25	2,3	100028

La clé P39L n'est pas fournie avec le porte outils - à cder séparément!
La chiave P39L non viene fornita con la portainserto - bisogna ordinarla separatamente!

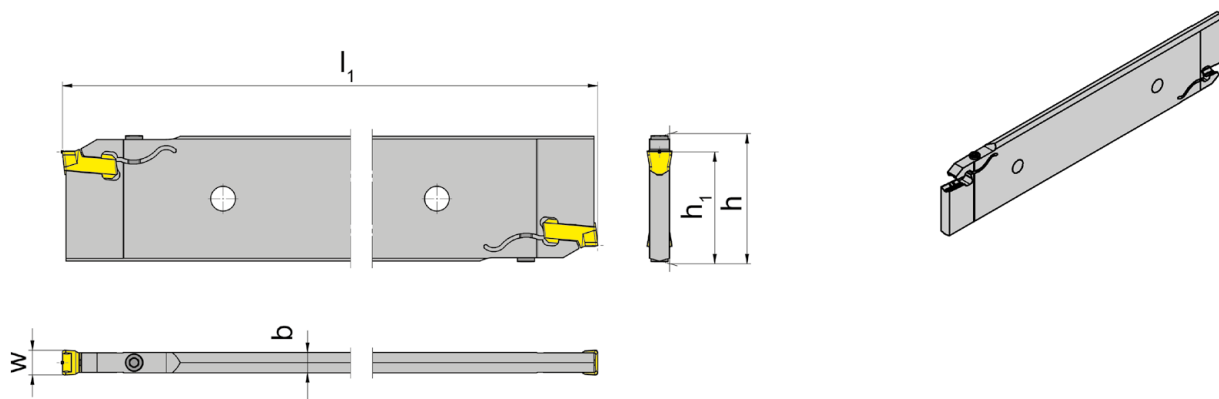
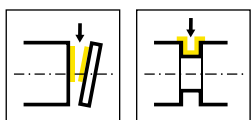

N° de commande Codice prodotto	h	b	l ₁	h ₁	HWS
H100.5208.26.08	52,6	7,4	260	45	100088
H100.5210.26.10	52,6	8,2	260	45	100108
H100.5212.26.12	52,6	10,4	260	45	100128

U

Pièces Détachées

Ricambi

Porte outils Portainsero	Vis de serrage Vite di serraggio	Tournevis TORX PLUS® Cacciavite TORX PLUS®
H100...	5.13T20P	T20PQ

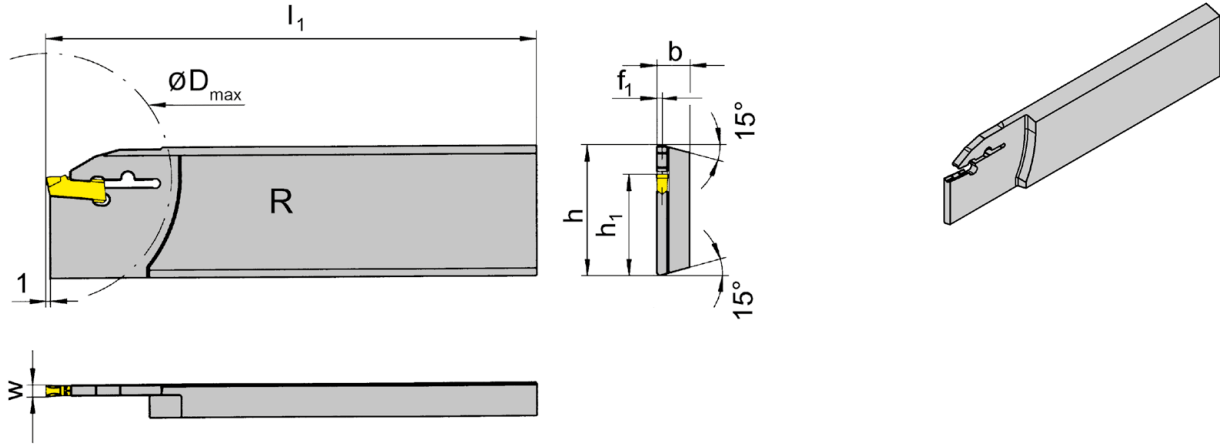
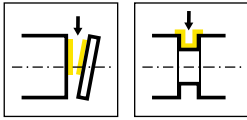

R = version à droite représentée
R = versione destra come in figura

L = version à gauche
L = versione sinistra a specchio

N° de commande Codice prodotto	h	b	l ₁	h ₁	f ₁	t _{max}	D _{max}	HWS
RH100.2608.31	26	7,9	110	21,4	0,75	21	42	100018
RH100.2608.32	26	7,9	110	21,4	0,95	25	50	100028
RH100.2608.33	26	7,9	110	21,4	1,15	25	50	100038
RH100.3208.31	32	7,9	112	24,8	0,75	25	50	100018
RH100.3208.32	32	7,9	112	24,8	0,95	34	68	100028
RH100.3208.33	32	7,9	112	24,8	1,15	34	68	100038
RH100.3208.34	32	7,9	112	24,8	1,55	34	68	100048
LH100.2608.31	26	7,9	110	21,4	0,75	21	42	100018
LH100.2608.32	26	7,9	110	21,4	0,95	25	50	100028
LH100.2608.33	26	7,9	110	21,4	1,15	25	50	100038
LH100.2608.34	26	7,9	110	21,4	1,55	25	50	100048
LH100.3208.31	32	7,9	112	24,8	0,75	25	50	100018
LH100.3208.32	32	7,9	112	24,8	0,95	34	68	100028
LH100.3208.33	32	7,9	112	24,8	1,15	34	68	100038
LH100.3208.34	32	7,9	112	24,8	1,55	34	68	100048

w voir plaquettes
w vd. inserti

La clé P39L n'est pas fournie avec le porte outils - à cder séparément!
La chiave P39L non viene fornita con la portainserto - bisogna ordinarla separatamente!

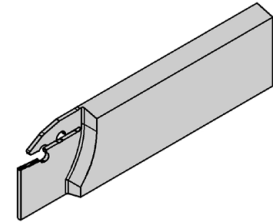
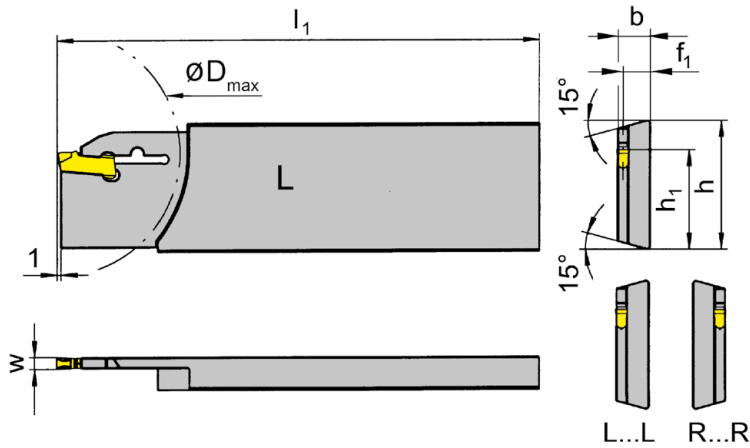
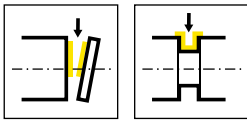

L = version à gauche représentée
L = versione sinistra come in figura

R = version à droite
R = versione destra a specchio

N° de commande Codice prodotto	h	b	l_1	h_1	f_1	t_{max}	D_{max}	HWS
RH100.2608.31R	26	7,9	110	21,4	7,15	21	42	100018
RH100.2608.32R	26	7,9	110	21,4	6,95	25	50	100028
RH100.2608.33R	26	7,9	110	21,4	6,75	25	50	100038
RH100.2608.34R	26	7,9	110	21,4	6,35	25	50	100048
RH100.3208.31R	32	7,9	112	24,8	7,15	25	50	100018
RH100.3208.32R	32	7,9	112	24,8	6,95	34	68	100028
RH100.3208.33R	32	7,9	112	24,8	6,75	34	68	100038
RH100.3208.34R	32	7,9	112	24,8	6,35	34	68	100048
LH100.2608.31L	26	7,9	110	21,4	7,15	21	42	100018
LH100.2608.32L	26	7,9	110	21,4	6,95	25	50	100028
LH100.2608.33L	26	7,9	110	21,4	6,75	25	50	100038
LH100.2608.34L	26	7,9	110	21,4	6,35	25	50	100048
LH100.3208.31L	32	7,9	112	24,8	7,15	25	50	100018
LH100.3208.32L	32	7,9	112	24,8	6,95	34	68	100028
LH100.3208.33L	32	7,9	112	24,8	6,75	34	68	100038
LH100.3208.34L	32	7,9	112	24,8	6,35	34	68	100048

w voir plaquettes
w vd. inserti

La clé P39L n'est pas fournie avec le porte outils - à cder séparément!
La chiave P39L non viene fornita con la portainserito - bisogna ordinarla separatamente!



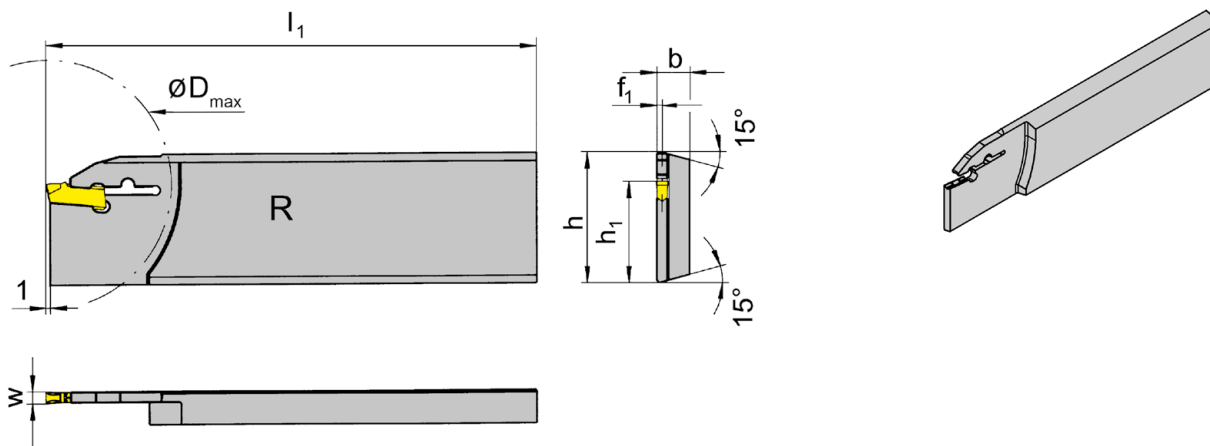
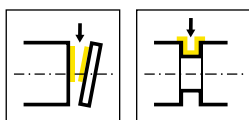

R = version à droite

R = versione destra

N° de commande Codice prodotto	h	b	l ₁	h ₁	f ₁	t _{max}	D _{max}	HWS
RH100.3208.2.44	32	7,9	160	24,8	1,55	41	80	100048
RH100.3208.44	32	7,9	130	24,8	1,55	41	80	100048

w voir plaquettes

w vd. inserti

La clé P39L n'est pas fournie avec le porte outils - à cder séparément!

La chiave P39L non viene fornita con la portainsero - bisogna ordinarla separatamente!

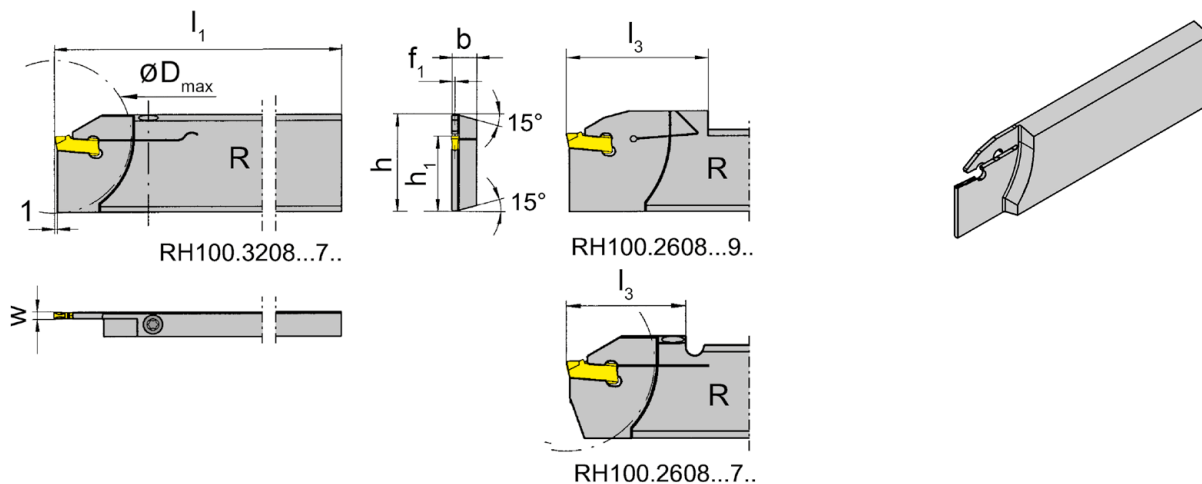
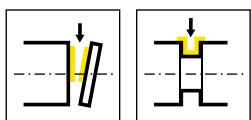

R = version à droite représentée
R = versione destra come in figura

L = version à gauche
L = versione sinistra a specchio

N° de commande Codice prodotto	h	b	l ₁	h ₁	f ₁	l ₃	t _{max}	D _{max}	HWS
RH100.2608.71	26	7,9	110	21,4	0,75	33,8	25	50	100018
RH100.2608.72	26	7,9	110	21,4	0,95	33,8	25	50	100028
RH100.2608.93	26	8	112	21,4	1,15	40	25	50	100038
RH100.3208.71	32	7,9	112	24,8	0,75	33,8	25	50	100018
RH100.3208.72	32	7,9	112	24,8	0,95	33,8	25	50	100028
RH100.3208.93	32	8	112	24,8	1,15	40	32,5	65	100038
LH100.2608.71	26	7,9	110	21,4	0,75	33,8	25	50	100018
LH100.2608.72	26	7,9	110	21,4	0,95	33,8	25	50	100028
LH100.2608.93	26	8	112	21,4	1,15	40	25	50	100038
LH100.3208.71	32	7,9	112	24,8	0,75	33,8	25	50	100018
LH100.3208.72	32	7,9	112	24,8	0,95	33,8	25	50	100028
LH100.3208.93	32	8	112	24,8	1,15	40	32,5	65	100038

w voir plaquettes
w vd. inserti

Pièces Détachées
Ricambi

Porte outils Portainsero	Vis de serrage Vite di serraggio	Tournevis TORX PLUS® Cacciavite TORX PLUS®
R/LH100...	4.15T15P	T15PQ
R/LH100...93	030.0413.T15P	T15PQ

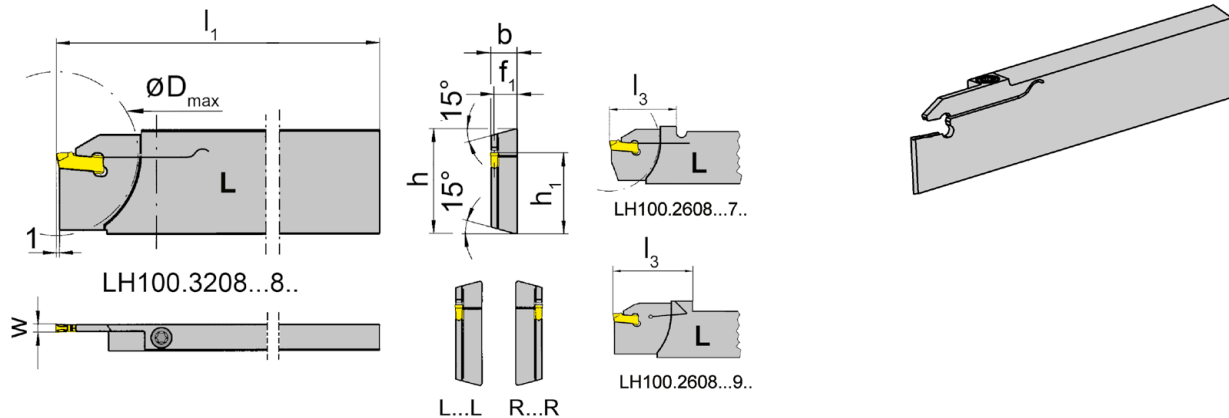
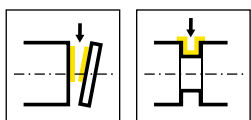

L = version à gauche représentée
L = versione sinistra come in figura

R = version à droite
R = versione destra a specchio

N° de commande Codice prodotto	h	b	l ₁	h ₁	f ₁	l ₃	t _{max}	D _{max}	HWS
RH100.2608.71R	26	7,9	110	21,4	7,15	33,8	25	50	100018
RH100.2608.72R	26	7,9	110	21,4	6,95	33,8	25	50	100028
RH100.2608.93R	26	8	115	21,4	6,85	40	25	50	100038
RH100.3208.71R	32	7,9	112	24,8	7,15	33,8	25	50	100018
RH100.3208.72R	32	7,9	112	24,8	6,95	33,8	25	50	100028
RH100.3208.93R	32	8	115	24,8	6,85	42	32,5	65	100038
LH100.2608.71L	26	7,9	110	21,4	7,15	33,8	25	50	100018
LH100.2608.72L	26	7,9	110	21,4	6,95	33,8	25	50	100028
LH100.2608.93L	26	8	115	21,4	6,85	40	25	50	100038
LH100.3208.71L	32	7,9	112	24,8	7,15	33,8	25	50	100018
LH100.3208.72L	32	7,9	112	24,8	6,95	33,8	25	50	100028
LH100.3208.93L	32	8	115	24,8	6,85	42	32,5	65	100038

w voir plaquettes
w vd. inserti

Pièces Détachées

Ricambi

Porte outils Portainsero	Vis de serrage Vite di serraggio	Tournevis TORX PLUS® Cacciavite TORX PLUS®
R/LH100...	4.15T15P	T15PQ
R/LH100...93R/L	030.0413.T15P	T15PQ

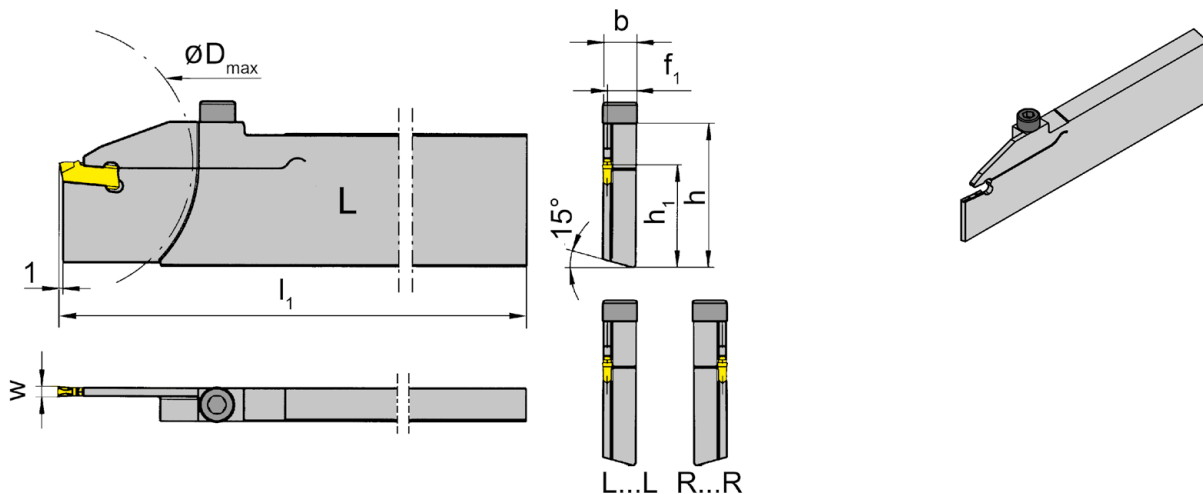
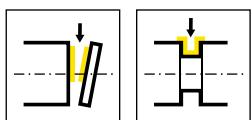

L = version à gauche représentée
L = versione sinistra come in figura

R = version à droite
R = versione destra a specchio

N° de commande Codice prodotto	h	b	l_1	h_1	f_1	t_{max}	D_{max}	HWS
RH100.3280.73R	32	7,9	130	24,8	6,75	32,5	65	100038
RH100.3280.74R	32	7,9	130	24,8	6,35	32,5	65	100048
LH100.3280.73L	32	7,9	130	24,8	6,75	32,5	65	100038
LH100.3280.74L	32	7,9	130	24,8	6,35	32,5	65	100048

pour machines TRAUB (TNX65)
per macchina utensile TRAUB (TNX65)

w voir plaquettes
w vd. inserti

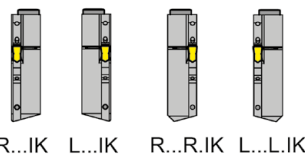
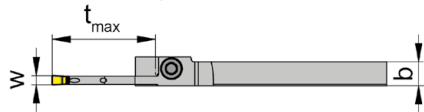
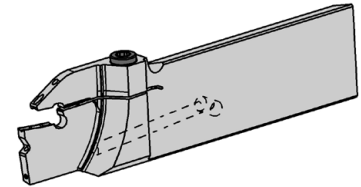
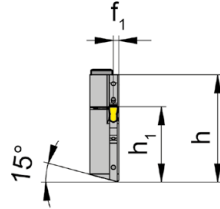
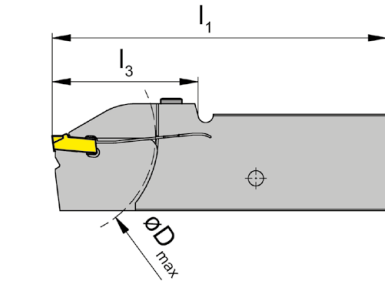
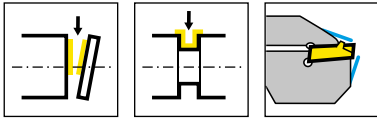

R...IK L...IK R...R.IK L...L.IK

L = version à gauche représentée
L = versione sinistra come in figura

R = version à droite
R = versione destra a specchio

N° de commande Codice prodotto	h	b	l ₁	h ₁	f ₁	l ₃	t _{max}	D _{max}	HWS
RH100.2608.26.4.73.IK	26	7,9	110	21,4	1,8	40	25	50	100038
RH100.2608.26.4.73R.IK	26	7,9	110	21,4	6,55	40	25	50	100038
RH100.3208.34.4.73.IK	32	7,9	110	24,8	1,8	48	34	68	100038
RH100.3208.34.4.73R.IK	32	7,9	110	24,8	6,55	48	34	68	100038
LH100.2608.26.4.73.IK	26	7,9	110	21,4	1,8	40	25	50	100038
LH100.2608.26.4.73L.IK	26	7,9	110	21,4	6,55	40	25	50	100038
LH100.3208.34.4.73.IK	32	7,9	110	24,8	1,8	48	34	68	100038
LH100.3208.34.4.73L.IK	32	7,9	110	24,8	6,55	48	34	68	100038

pour machines TRAUB et INDEX
per macchina TRAUB e INDEX

w voir plaquettes
w vd. inserti

Pièces Détachées

Ricambi

Porte outils Portainsero	Vis de serrage Vite di serraggio	Tournevis TORX PLUS® Cacciavite TORX PLUS®
R/LH100...	5.13T20P	T20PQ

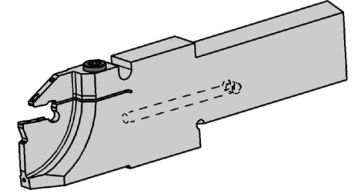
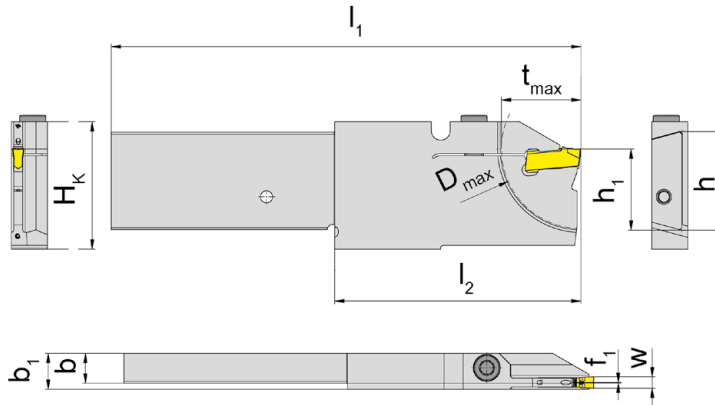
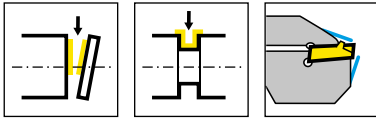

L = version à gauche représentée
L = versione sinistra come in figura

R = version à droite
R = versione destra a specchio

N° de commande Codice prodotto	H _k	h	b	l ₁	h ₁	f	t _{max}	l ₂	D _{max}	b ₁	HWS
RH100.2608.2.16.4.72.IK	33,6	26	7,9	124	21,4	0,2	16	65	32	9,5	100028
RH100.2608.2.16.4.72R.IK	33,6	26	7,9	124	21,4	6,4	16	65	32	9,5	100028
RH100.2608.2.21.4.73.IK	33,6	26	7,9	124	21,4	0,2	21	65	42	9,5	100038
RH100.2608.2.21.4.73R.IK	33,6	26	7,9	124	21,4	6,4	21	65	42	9,5	100038

pour machines DMG MORI (Multisprint)
per macchina TRAUB e INDEX

w voir plaquettes
w vd. inserti



Pièces Détachées

Ricambi

Porte outils Portainsero	Vis de serrage Vite di serraggio	Tournevis TORX PLUS® Cacciavite TORX PLUS®
RH100...	5.13T20P	T20PQ

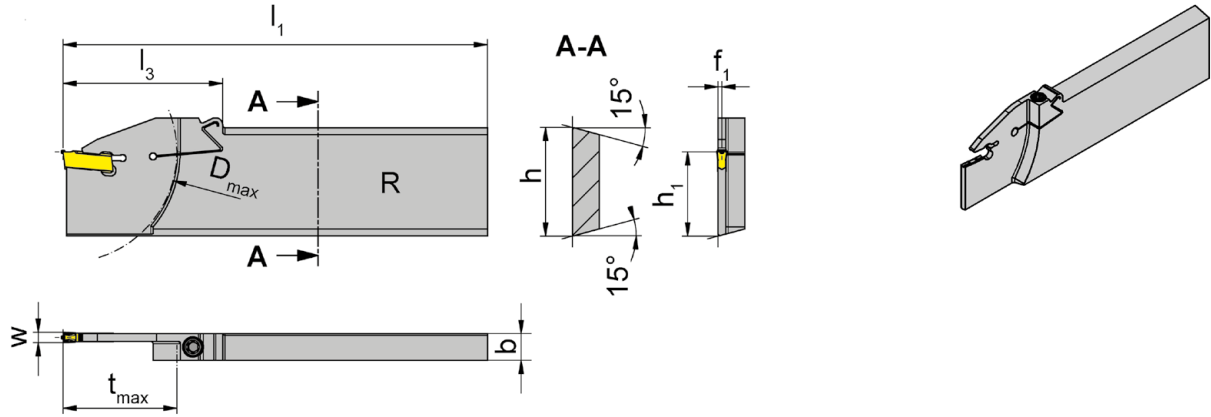
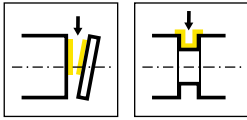

R = version à droite représentée
R = versione destra come in figura

L = version à gauche
L = versione sinistra a specchio

N° de commande Codice prodotto	h	b	l ₁	h ₁	f ₁	l ₃	t _{max}	D _{max}	Type de machine Tipo macchina	HWS
RH100.3208.83	32	8	125	24,8	1,15	47	33,5	65	TraubTNX65/42, IndexC65	100038
LH100.3208.15.83	32	8	150	24,8	1,15	47	33,5	65	TraubTNX65/42, IndexC65	100038
LH100.3208.83	32	8	125	24,8	1,15	47	33,5	65	TraubTNX65/42, IndexC65	100038
LH100.3208.84	32	8	125	24,8	1,5	47	33,5	65	TraubTNX65/42, IndexC65	100048

pour machines TRAUB et INDEX
per macchina TRAUB e INDEX

w voir plaquettes
w vd. inserti

Pièces Détachées
Ricambi

Porte outils Portainsero	Vis de serrage Vite di serraggio	Tournevis TORX PLUS® Cacciavite TORX PLUS®
LH100.3208.15.83	030.505P.0718	T15PL
R/LH100...	030.505P.0718	T15PQ



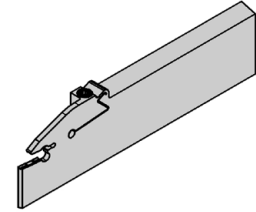
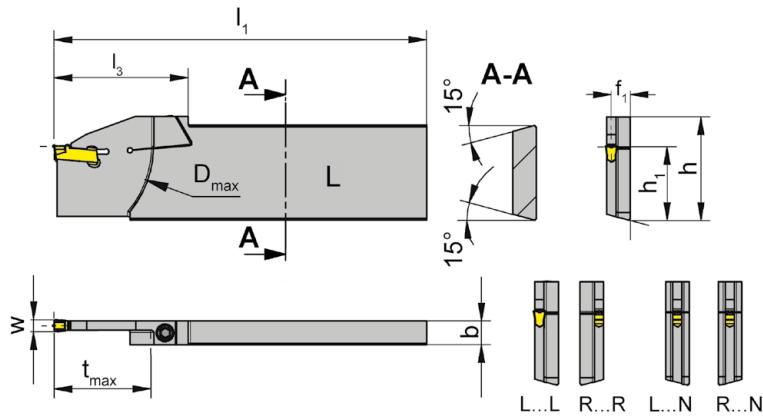
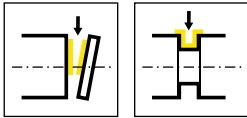

L = version à gauche représentée
L = versione sinistra come in figura

R = version à droite
R = versione destra a specchio

N° de commande Codice prodotto	h	b	l ₁	h ₁	f ₁	l ₃	t _{max}	D _{max}	Type de machine Tipo macchina	HWS
RH100.3208.83N	32	8	125	24,8	4	47	33,5	65	TraubTNX65/42, IndexC65	100038
RH100.3208.83R	32	8	125	24,8	6,85	47	33,5	65	TraubTNX65/42, IndexC65	100038
RH100.3208.84N	32	8	134	24,8	4	54,5	41	80	TraubTNX80/65	100048
RH100.3208.84R	32	8	125	24,8	6,5	47	33,5	65	TraubTNX65/42, IndexC65	100048
LH100.3208.83L	32	8	125	24,8	6,85	47	33,5	65	TraubTNX65/42, IndexC65	100038
LH100.3208.83N	32	8	125	24,8	4	47	33,5	65	TraubTNX65/42, IndexC65	100038
LH100.3208.84L	32	8	125	24,8	6,5	47	33,5	65	TraubTNX65/42, IndexC65	100048
LH100.3208.84N	32	8	134	24,8	4	54,5	41	80	TraubTNX80/65	100048

pour machines REIKA
per macchina REIKA

w voir plaquettes
w vd. inserti

Pièces Détachées

Ricambi

Porte outils Portainsero	Vis de serrage Vite di serraggio	Tournevis TORX PLUS® Cacciavite TORX PLUS®
R/LH100.3208....	030.505P.0718	T15PQ



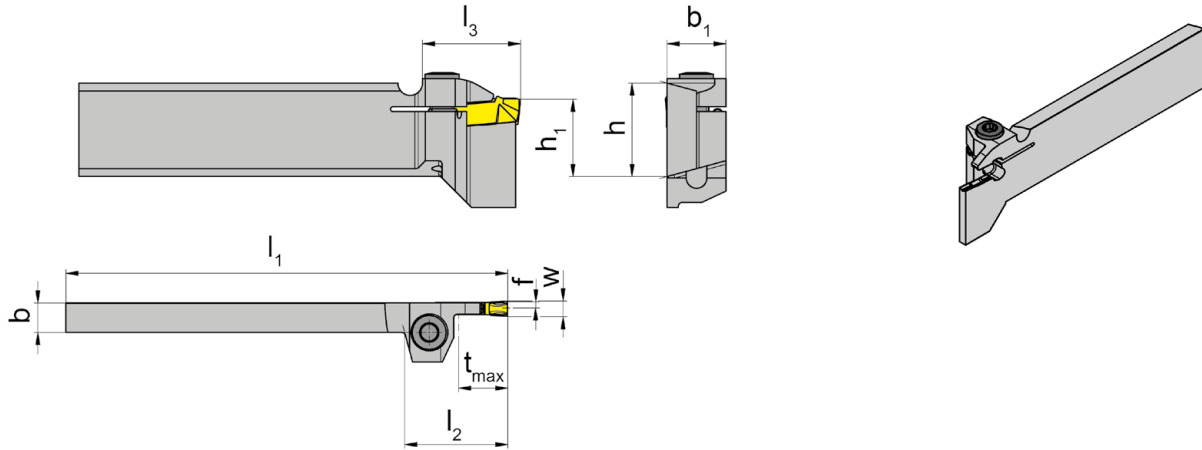
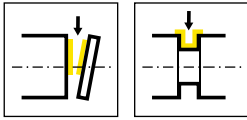

L = version à gauche représentée
L = versione sinistra come in figura

N° de commande Codice prodotto	h	b	l ₁	h ₁	l ₂	f	l ₃	t _{max}	b ₁	HWS
LH100.1908.R.13	19	8	90	15,7	16	1,15	20	10	12	100038
LH100.3208.R.13	32	8	110	24,8	16	1,15	20	10	12	100038

pour machines REIKA
per macchina REIKA
w voir plaquettes
w vd. inserti

U

Pièces Détachées
Ricambi

Porte outils Portainsero	Vis de serrage Vite di serraggio	Tournevis TORX PLUS® Cacciavite TORX PLUS®
LH100.1908.R.13	5.17T20P	T20PW
LH100.3208.R.13	5.17T20P	T20PQ

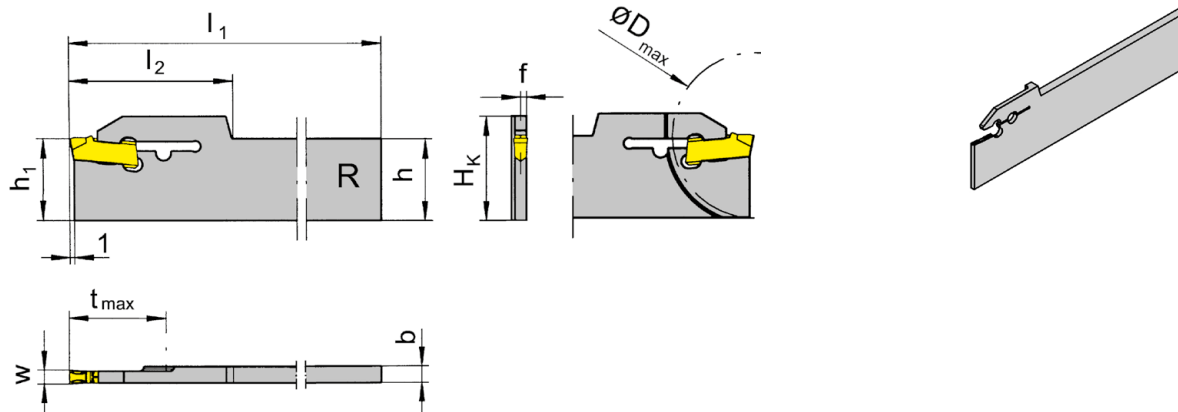
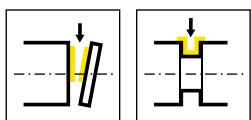

R = version à droite

R = versione destra

N° de commande Codice prodotto	H _K	b	l ₁	h ₁	f	l ₂	t _{max}	D _{max}	h	HWS
RH100.1703.21	22,1	3,2	110	17,4	0,75	32	17,5	35	17,4	100018
RH100.1703.33	22,1	3,2	110	17,4	1,15	34,5	30	60	17,4	100038
RH100.2203.21	26,9	3,2	150	22,2	0,75	32	32	50	22,1	100018
RH100.2203.33	26,9	3,2	150	22,2	1,15	34,5	38	76	22,1	100038

w voir plaquettes

w vd. inserti

La clé **P39L** n'est pas fournie avec la lame R/LH100...33 - à cder séparément!

La chiave **P39L** non viene fornita con la lama R/LH100...33 - bisogna ordinarla separatamente!

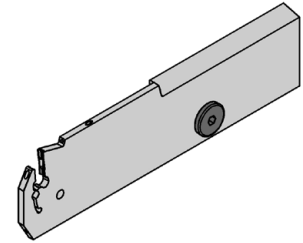
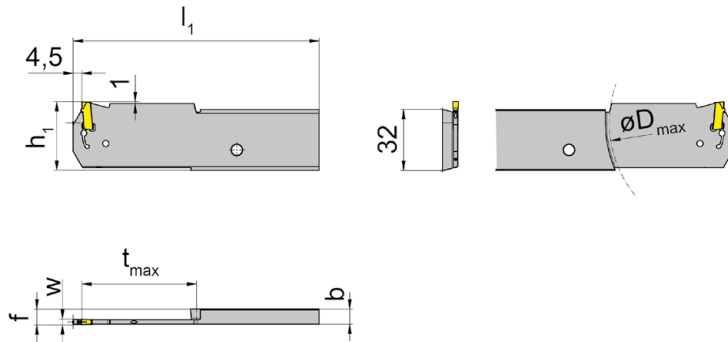
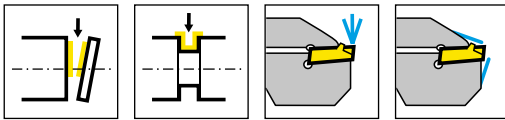

R = version à droite représentée
R = versione destra come in figura

L = version à gauche
L = versione sinistra a specchio

N° de commande Codice prodotto	b	l ₁	h ₁	f	t _{max}	D _{max}	HWS
RH100.3208.Y.60.3.83.IK*	7,9	128,5	36	8,25	60	120	100039 • 100038
RH100.3208.Y.60.3.84.IK*	7,9	128,5	36	8,25	60	120	100049 • 100048
RH100.3208.Y.60.4.83.IK	7,9	128,5	36	8,25	60	120	100038
RH100.3208.Y.60.4.84.IK	7,9	128,5	36	8,25	60	120	100048
LH100.3208.Y.60.3.83.IK*	7,9	128,5	36	8,25	60	120	100039 • 100038
LH100.3208.Y.60.3.84.IK*	7,9	128,5	36	8,25	60	120	100049 • 100048
LH100.3208.Y.60.4.83.IK	7,9	128,5	36	8,25	60	120	100038
LH100.3208.Y.60.4.84.IK	7,9	128,5	36	8,25	60	120	100048

* = Arrosage central sur la plaquette

* = Adduzione del lubrorefrigerante attraverso l'inserto

w voir plaquettes
w vd. inserti

La clé **P101.02** n'est pas fournie avec le fraise - à cder séparément!
La chiave P101.02 non viene fornita con fresa - bisogna ordinarla separatamente!

Pièces Détachées

Ricambi

Porte outils Portainserito	
R/LH100...	020.IK01.5732

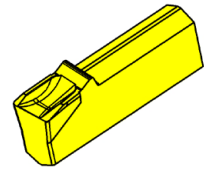
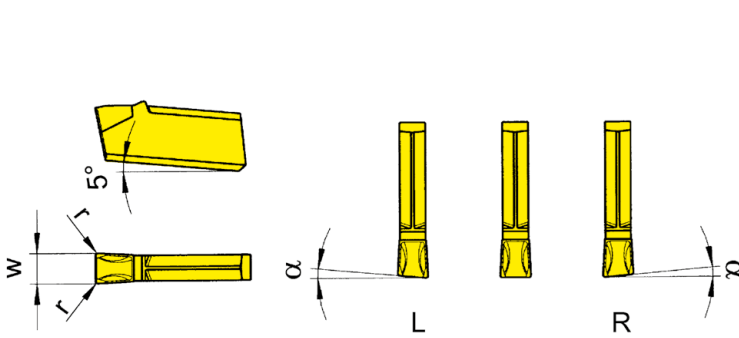
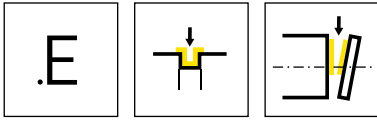

R = version à droite
R = versione destra

L = version à gauche
L = versione sinistra

Nuance
Leghe
▲ en stock
a stock
Δ 4 semaines
4 settimane

N° de commande Codice prodotto	w	r	α	HIS	ALX2	ALX3	AS63	AS66	TC92	TC93	TF42	TF43	TF45	TF46	TI22
RS100.0520.E2	2	0,2	5°	100018					Δ			▲	▲	Δ	
RS100.0525.E2	2,5	0,2	5°	100028					Δ	▲		▲	▲	Δ	Δ
RS100.0530.E2	3	0,2	5°	100038		▲			Δ	Δ	▲	▲	▲	▲	▲
RS100.0540.E2	4	0,2	5°	100048		Δ			Δ	Δ		▲	▲	Δ	Δ
LS100.0520.E2	2	0,2	5°	100018					Δ	Δ		Δ	▲	Δ	
LS100.0525.E2	2,5	0,2	5°	100028					Δ	Δ		Δ	Δ	Δ	Δ
LS100.0530.E2	3	0,2	5°	100038		▲			▲	Δ	Δ	▲	▲	▲	Δ
LS100.0540.E2	4	0,2	5°	100048		Δ			Δ	Δ		▲	▲	Δ	
S100.0200.E2	2	0,2	0°	100018		▲			▲	Δ		▲	▲	▲	
S100.0300.E2	3	0,2	0°	100038	▲	▲	▲	▲	▲	▲	▲	▲	▲	▲	▲
S100.0400.E3	4	0,3	0°	100048		▲			▲	▲		▲	▲	▲	
S100.0500.E3	5	0,3	0°	100058				Δ	Δ	▲		▲	▲	▲	Δ
P	●	●	●	●	●	●	●	●	●	●	●	●	●	●	●
M	-	-	-	○	-	-	-	○	-	-	-	-	●	○	-
K	-	-	-	●	-	-	-	●	-	-	-	-	●	●	-
N	-	-	-	●	-	-	-	●	-	-	-	-	●	●	-
S	-	-	-	○	-	-	-	○	-	-	-	-	●	○	-
H	-	-	-	-	-	-	-	-	-	-	-	-	-	-	-



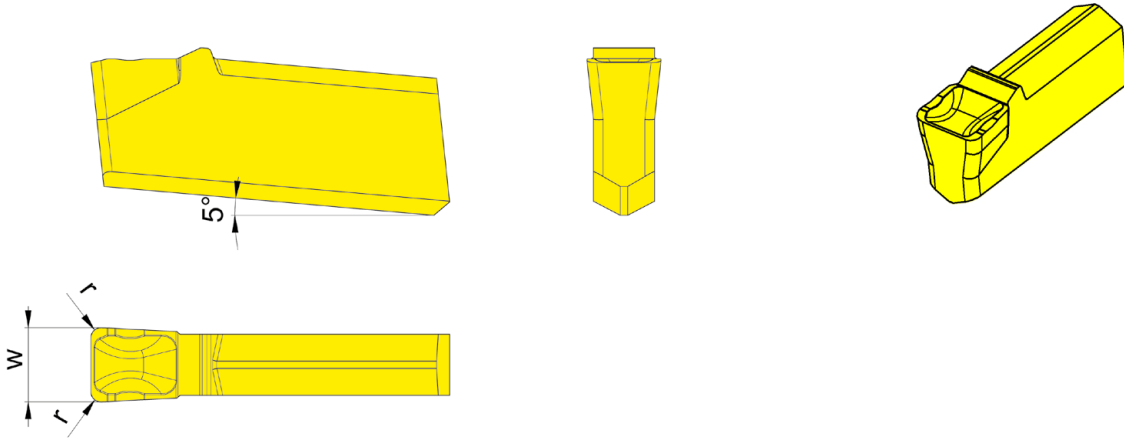
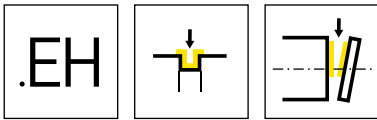

Nuance
Leghe

▲ en stock
a stock

Δ 4 semaines
4 settimane

N° de commande Codice prodotto	w	r	HIS	IG6G
S100.0300.EH4	3	0,4	100038	▲
S100.0400.EH6	4	0,6	100048	▲
				P ●
				M o
				K o
				N -
				S -
				H -



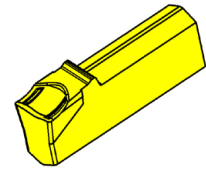
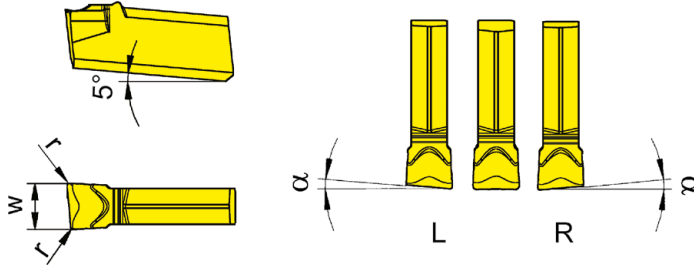
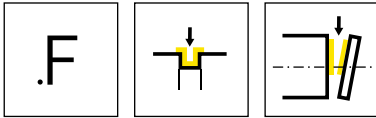

R = version à droite représentée
R = versione destra come in figura

L = version à gauche
L = versione sinistra a specchio

Nuance
Leghe
▲ en stock
a stock
Δ 4 semaines
4 settimane

N° de commande Codice prodotto	w	r	α	HIS	TC92	TC93	TF42	TF43	TF45	TF46	TI22
RS100.0520.F2	2	0,2	5°	100018	Δ	Δ		Δ	▲		Δ
RS100.0525.F2	2,5	0,2	5°	100028	Δ	Δ		Δ	▲	Δ	Δ
RS100.0530.F2	3	0,2	5°	100038	Δ	Δ		▲	▲	▲	Δ
LS100.0520.F2	2	0,2	5°	100018	Δ	Δ		Δ		Δ	Δ
LS100.0525.F2	2,5	0,2	5°	100028	Δ	Δ		Δ	▲	Δ	Δ
LS100.0530.F2	3	0,2	5°	100038	Δ			Δ	▲	▲	▲
S100.0200.F2	2	0,2	-	100018	▲	Δ		▲	▲	▲	▲
S100.0300.F2	3	0,2	0°	100038		▲	Δ	▲	▲	▲	▲
S100.0400.F3	4	0,3	0°	100048	Δ	▲		▲	▲	▲	▲
S100.0500.F3	5	0,3	0°	100058	Δ			Δ	▲	Δ	▲
P	●	●	●	●	●	●	●	●	●	●	●
M	-	-	-	-	●	○	-	-	○	-	-
K	-	-	-	-	●	○	-	-	○	-	-
N	-	-	-	-	●	○	-	-	○	-	-
S	-	-	-	-	●	○	-	-	○	-	-
H	-	-	-	-	●	○	-	-	○	-	-



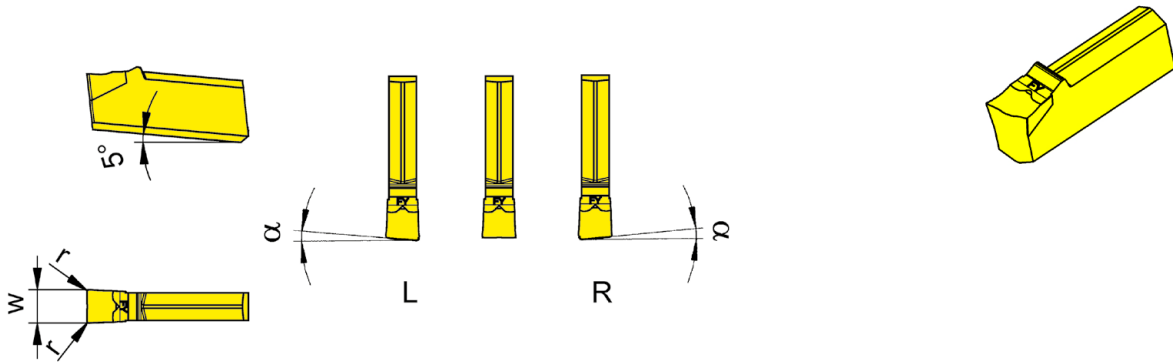
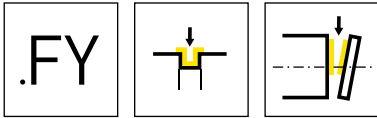

R = version à droite
R = versione destra

L = version à gauche
L = versione sinistra

Nuance
Leghe
▲ en stock
a stock
Δ 4 semaines
4 settimane

N° de commande Codice prodotto	w	r	α	HIS	Nuance				
					AS45	HP65	IG35	PH35	TI25
RS100.1520.FY0	2	0	15°	100018	▲		▲		
RS100.1530.FY0	3	-	15°	100038	▲		▲		
LS100.1520.FY0	2	0	15°	100018	▲		▲		
LS100.1530.FY0	3	-	15°	100038	▲		▲		
S100.0200.FY2	2	0,2	-	100018	Δ	▲	▲	Δ	▲
S100.0220.FY2	2,2	0,2	0°	100018			▲		▲
S100.0250.FY2	2,5	0,2	0°	100028	Δ	▲	▲		▲
S100.0300.FY2	3	0,2	0°	100038	Δ	▲	▲		▲
S100.0400.FY3	4	0,3	0°	100048		▲	▲		▲
P	●	●	-	○	●				
M	●	●	●	○	●				
K	●	●	-	●	●				
N	○	○	-	-	●				
S	●	●	●	-	●				
H	-	-	-	-	-				

U

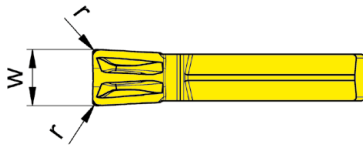
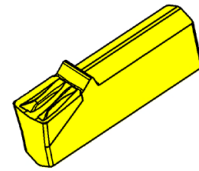
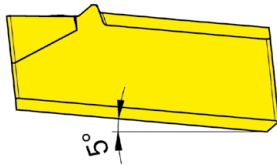
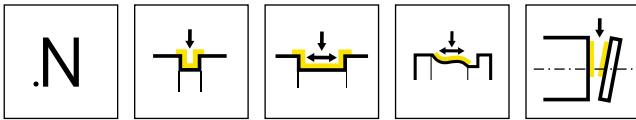

Nuance
Leghe

▲ en stock
a stock

Δ 4 semaines
4 settimane

N° de commande Codice prodotto	w	r	HIS	Nuance	
				AS45	HP65
S100.0300.N2	3	0,2	100038	▲	▲
S100.0400.N3	4	0,3	100048	▲	▲
				P ●	●
				M ●	●
				K ●	●
				N o	o
				S ●	●
				H -	-



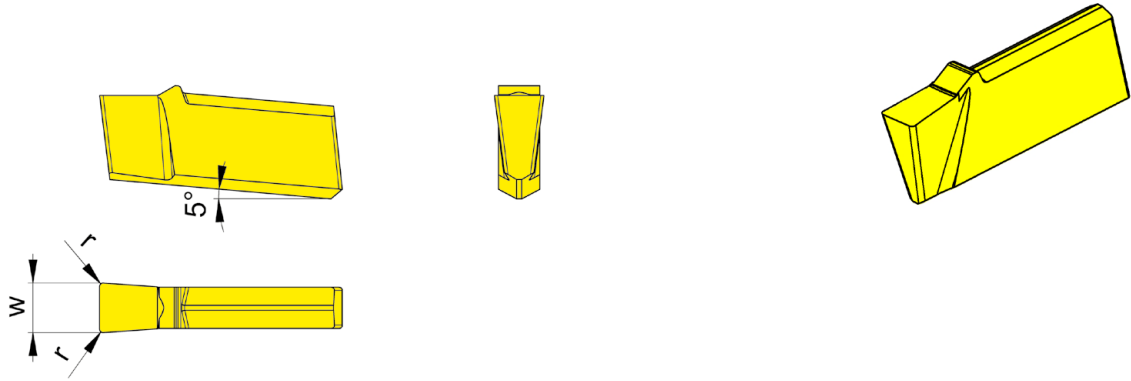
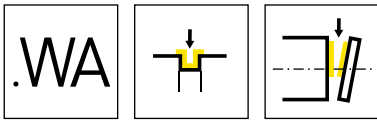

Nuance
Leghe

▲ en stock
a stock

Δ 4 semaines
4 settimane

N° de commande Codice prodotto	w	r	HIS	K10	DD26
S100.0200.WA2	2	0,2	100018	▲	▲
S100.0300.WA2	3	0,2	100038	▲	▲
				P ● -	
				M ○ -	
				K ● -	
				N ● ●	
				S ○ ○	
				H - -	

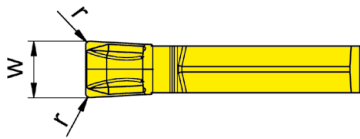
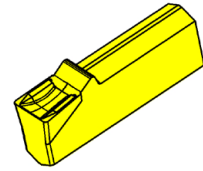
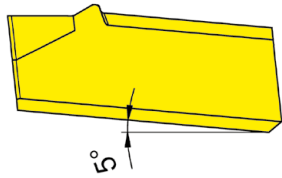
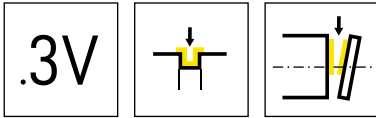

Nuance
Leghe

▲ en stock
a stock

Δ 4 semaines
4 settimane

N° de commande Codice prodotto	w	r	HIS					
				AS45	HP35	HP65	IG35	PH35
S100.0200.3V2	2	0,2	100018	▲	Δ	▲	▲	Δ
S100.0250.3V2	2,5	0,2	100028	▲		▲	▲	
S100.0300.3V2	3	0,2	100038	▲		▲	▲	
S100.0400.3V3	4	0,3	100048	▲		▲	▲	
P	●	○	●	-	○			
M	●	●	●	●	○			
K	●	○	●	-	●			
N	○	-	○	-	-			
S	●	○	●	●	-			
H	-	-	-	-	-			



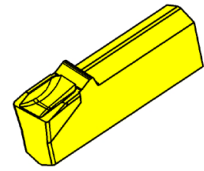
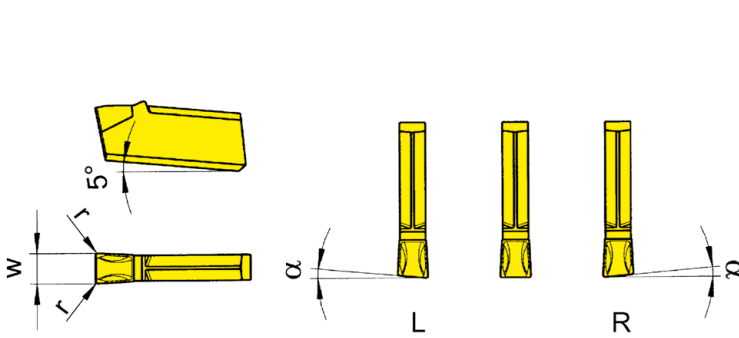
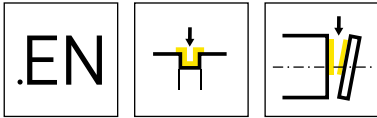

R = version à droite
R = versione destra

L = version à gauche
L = versione sinistra

▲ en stock
a stock

Δ 4 semaines
4 settimane

Nuance
Leghe

N° de commande Codice prodotto	w	r	α	HIS	ALX3	ALX5	AS62	AS63	AS66	AS6G	TF45	TH35
RS100.0540.EN2	4	0,2	5°	100048	▲							
RS100.0530.EN2	3	0,2	5°	100038			▲		▲			
LS100.0480.EN8	8	0,8	4°	100088					▲			
LS100.0540.EN2	4	0,2	5°	100048	▲							
S100.0200.EN2	2	0,2	0°	100018	▲	Δ				▲		Δ
S100.0300.EN2	3	0,2	0°	100038	▲	Δ			▲	▲	Δ	
S100.0400.EN3	4	0,3	0°	100048	▲			▲		▲		
S100.0500.EN3	5	0,3	0°	100058	▲					▲		
S100.0600.EN6	6	0,6	0°	100068						▲		
S100.0800.EN8	8	0,8	0°	100088						▲		
S100.1000.EN8	10	0,8	0°	100108						▲		
S100.1200.EN8	12	0,8	0°	100128						▲		
S100.1600.EN8	16	0,8	0°	100168						▲		
P	●	●	●	●	●	●	●	●	●	●	●	●
M	-	●	-	-	○	●	-	-	○	●	●	●
K	-	●	-	-	●	●	-	-	●	●	●	●
N	-	●	-	-	●	●	-	-	●	●	●	●
S	-	●	-	-	○	●	-	-	○	●	●	●
H	-	-	-	-	-	-	-	-	-	-	-	-

U

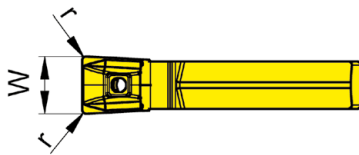
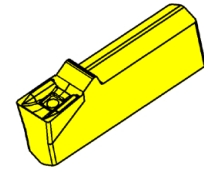
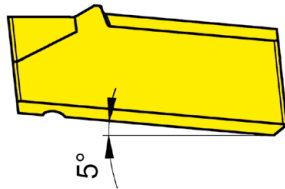
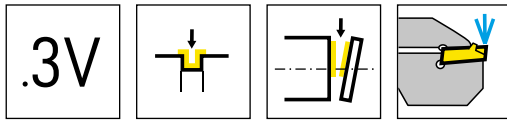

Nuance
Leghe

▲ en stock
a stock

Δ 4 semaines
4 settimane

N° de commande Codice prodotto	w	r	HIS	Nuance	
				HP65	IG35
S100.0250.3V2.IK	2,5	0,2	100029	▲	▲
S100.0300.3V2.IK	3	0,2	100039	▲	▲
				P ● -	
				M ● ●	
				K ● -	
				N ○ -	
				S ● ●	
				H - -	



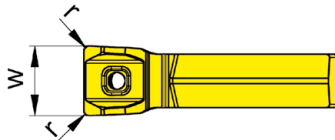
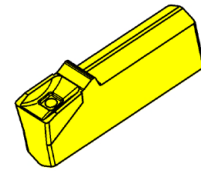
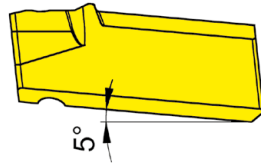
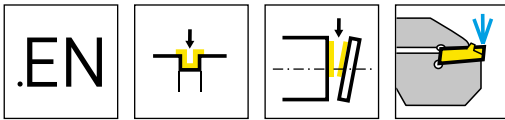

Nuance
Leghe

▲ en stock
a stock

Δ 4 semaines
4 settimane

N° de commande Codice prodotto	w	r	HIS	Nuance Leghe		
				AS45	EG55	HP65
S100.0250.EN2.IK	2,5	0,2	100029	▲	Δ	▲
S100.0300.EN2.IK	3	0,2	100039	▲	▲	▲
S100.0400.EN3.IK	4	0,3	100049	▲	▲	▲
P	●	●	●	●	●	●
M	●	○	●	●	○	●
K	●	○	●	●	○	●
N	○	-	○	○	-	○
S	●	-	●	●	-	●
H	-	-	-	-	-	-

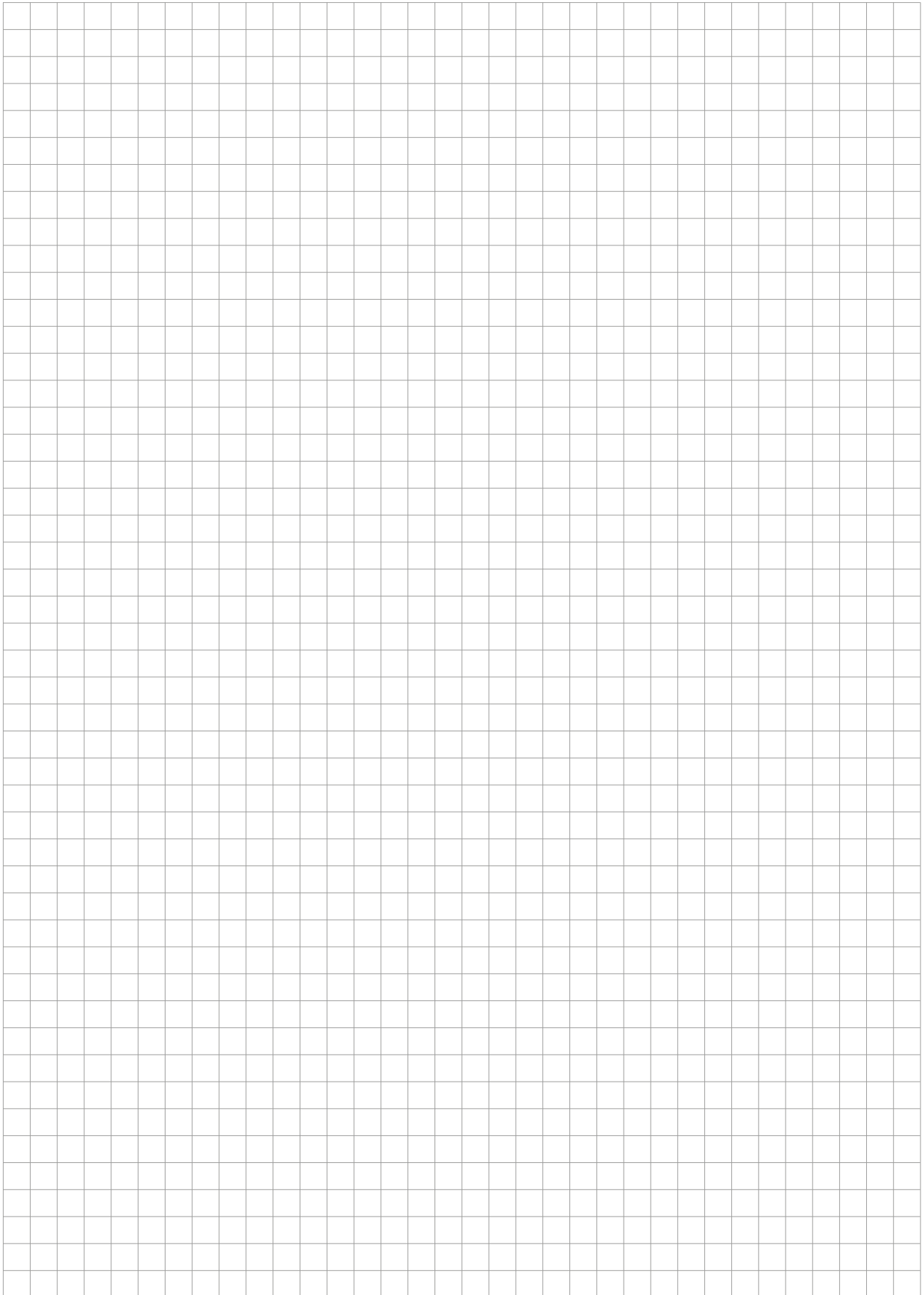

U

Porte outils
Portainsero
H223

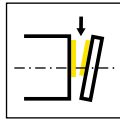

Page/Pag.
638

Plaque amovible
Inserto
S223

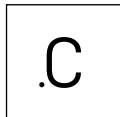

Page/Pag.
639-640

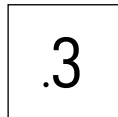

Page/Pag.
641

Informations techniques
Informazioni tecniche

Page/Pag
713