

15A/25A



T

Porte outils et plaquettes

Largeur de gorge 2 - 4 mm

Portainserito e inserti

Larghezza della gola 2 - 4 mm

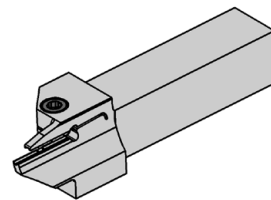
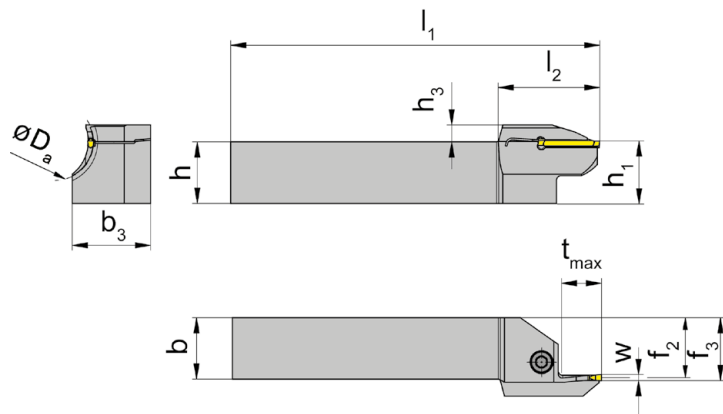
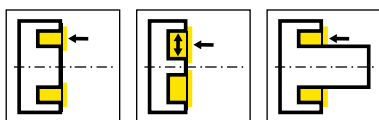

L = version à gauche représentée
L = versione sinistra come in figura

R = version à droite
R = versione destra a specchio

N° de commande Codice prodotto	h	b	l ₁	l ₂	h ₁	b ₃	f ₂	f ₃	t _{max}	h ₃	D _{a min}	D _{a max}	HWS
RAH25A.12.1520.02	12	12	120	32	12,3	15,5	11,5	12,5	12	5	15	20	25A02
RAH25A.12.2025.02	12	12	120	32	12,3	16,5	11,5	12,5	12	5	20	25	25A02
RAH25A.12.2530.02	12	12	120	33	12,3	17,5	11,5	12,5	13	5,5	25	30	25A02
RAH25A.16.1520.02	16	16	120	32	16,3	19,5	15,5	16,5	12	5	15	20	25A02
RAH25A.16.2025.02	16	16	120	32	16,3	20,5	15,5	16,5	12	5	20	25	25A02
RAH25A.16.2530.02	16	16	120	33	16,3	21,5	15,5	16,5	13	5,5	25	30	25A02
RAH25A.20.1520.02	20	20	120	32	20,3	23,5	19,5	20,5	12	5	15	20	25A02
RAH25A.20.2025.02	20	20	120	32	20,3	24,5	19,5	20,5	12	5	20	25	25A02
RAH25A.20.2530.02	20	20	120	33	20,3	25,5	19,5	20,5	13	5,5	25	30	25A02
LAH25A.12.1520.02	12	12	120	32	12,3	15,5	11,5	12,5	12	5	15	20	25A02
LAH25A.12.2025.02	12	12	120	32	12,3	16,5	11,5	12,5	12	5	20	25	25A02
LAH25A.12.2530.02	12	12	120	33	12,3	17,5	11,5	12,5	13	5,5	25	30	25A02
LAH25A.16.1520.02	16	16	120	32	16,3	19,5	15,5	16,5	12	5	15	20	25A02
LAH25A.16.2025.02	16	16	120	32	16,3	20,5	15,5	16,5	12	5	20	25	25A02
LAH25A.16.2530.02	16	16	120	33	16,3	21,5	15,5	16,5	13	5,5	25	30	25A02
LAH25A.20.1520.02	20	20	120	32	20,3	23,5	19,5	20,5	12	5	15	20	25A02
LAH25A.20.2025.02	20	20	120	32	20,3	24,5	19,5	20,5	12	5	20	25	25A02
LAH25A.20.2025.03	20	20	120	34	20,3	26,5	19	20,5	14	5,5	20	25	25A03
LAH25A.20.2530.02	20	20	120	33	20,3	25,5	19,5	20,5	13	5,5	25	30	25A02

L'arête de coupe doit être réglé de 0,3 mm au-dessus de la hauteur de centre
Il tagliente deve essere posizionato 0,3 mm sopra centro

w voir plaquettes amovibles
w vd. inserti

Pièces Détachées

Ricambi

Porte outils Portainsero	Vis de serrage Vite di serraggio	Tournevis TORX PLUS® Cacciavite TORX PLUS®
R/LAH25A.12...	5.14T20P	T20PQ
R/LAH25A...	5.13T20P	T20PQ

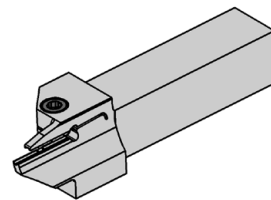
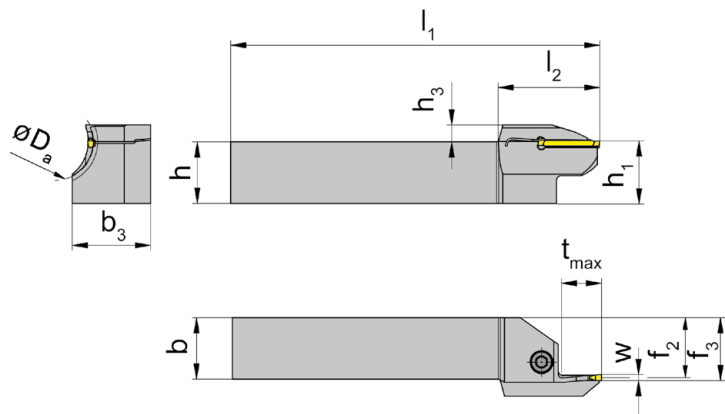
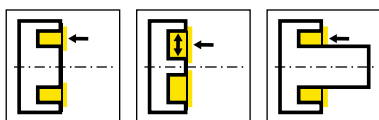

L = version à gauche représentée
L = versione sinistra come in figura

R = version à droite
R = versione destra a specchio

N° de commande Codice prodotto	h	b	l ₁	l ₂	h ₁	b ₃	f ₂	f ₃	t _{max}	h ₃	D _{a min}	D _{a max}	HWS
RAH25A.12.1520.03	12	12	120	32	12,3	17	11	12,5	13	5,5	15	20	25A03
RAH25A.16.1520.03	16	16	120	32	16,3	21	15	16,5	13	5,5	15	20	25A03
RAH25A.20.1520.03	20	20	120	33	20,3	25	19	20,5	13	5,5	15	20	25A03
RAH25A.16.2025.03	16	16	120	34	16,3	22,5	15	16,5	14	5	20	25	25A03
RAH25A.20.2025.03	20	20	120	34	20,3	26,5	19	20,5	14	5,5	20	25	25A03
RAH25A.12.2530.03	12	12	120	35	12,3	19,5	11	12,5	15	6	25	30	25A03
RAH25A.16.2530.03	16	16	120	35	16,3	23,5	15	16,5	15	6	25	30	25A03
RAH25A.20.2530.03	20	20	120	35	20,3	27,5	19	20,5	15	6	25	30	25A03
LAH25A.12.1520.03	12	12	120	33	12,3	17	11	12,5	13	5,5	15	20	25A03
LAH25A.16.1520.03	16	16	120	33	16,3	21	15	16,5	13	5,5	15	20	25A03
LAH25A.20.1520.03	20	20	120	33	20,3	25	19	20,5	13	5,5	15	20	25A03
LAH25A.12.2025.03	12	12	120	34	12,3	18,5	11	12,5	14	5,5	20	25	25A03
LAH25A.16.2025.03	16	16	120	34	16,3	22,5	15	16,5	14	5,5	20	25	25A03
LAH25A.20.2025.03	20	20	120	34	20,3	26,5	19	20,5	14	5,5	20	25	25A03
LAH25A.16.2530.03	16	16	120	35	16,3	23,5	15	16,5	15	6	25	30	25A03
LAH25A.20.2530.03	20	20	120	35	20,3	27,5	19	20,5	15	6	25	30	25A03

L'arête de coupe doit être réglé de 0,3 mm au-dessus de la hauteur de centre
Il tagliente deve essere posizionato 0,3 mm sopra centro

w voir plaquettes amovibles
w vd. inserti

Pièces Détachées

Ricambi

Porte outils Portainserto	Vis de serrage Vite di serraggio	Tournevis TORX PLUS® Cacciavite TORX PLUS®
R/LAH25A.12...	5.14T20P	T20PQ
R/LAH25A...	5.13T20P	T20PQ

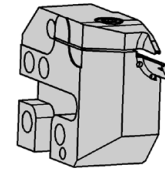
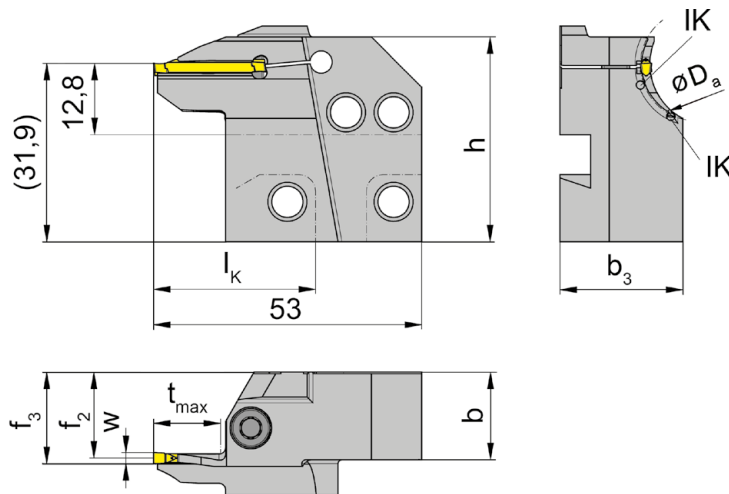
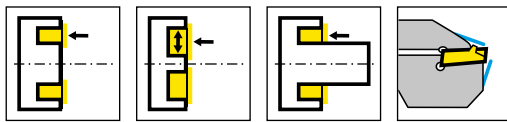

R = version à droite représentée
R = versione destra come in figura

L = version à gauche
L = versione sinistra a specchio

N° de commande Codice prodotto	D _{a min}	D _{a max}	t _{max}	b	b ₃	f ₂	f ₃	w	h	l _k	HWS	HMS
RAK25A.1520.02.IK	15	20	12	15,7	21	15,4	f ₂ +w/2	2	38,6	34	25A02	220001
RAK25A.2025.02.IK	20	25	12	15,7	22	15,4	f ₂ +w/2	2	38,6	34	25A02	220001
RAK25A.2530.02.IK	25	30	13	15,7	23	15,4	f ₂ +w/2	2	38,6	34	25A02	220001
RAK25A.2025.03.IK	20	25	14	15,7	24	14,9	f ₂ +w/2	3	38,6	34	25A03	220001
RAK25A.2530.03.IK	25	30	15	15,7	25	14,9	f ₂ +w/2	3	38,6	34	25A03	220001
RAK25A.3040.03.IK	30	40	16	15,7	23	14,9	f ₂ +w/2	3	38,6	34	25A03	220001
RAK25A.4050.03.IK	40	50	18	15,7	24	14,9	f ₂ +w/2	3	38,6	34	25A03	220001
RAK25A.5065.03.IK	65	80	18	15,7	21,5	15,4	f ₂ +w/2	3	39	34	25A03	220001
RAK25A.6580.03.IK	50	65	20	15,7	24	17,1	f ₂ +w/2	3	39	34	25A03	220001
RAK25A.2025.04.IK	20	25	16	15,7	24	15,1	f ₂ +w/2	4	38,6	34	25A04	220001
RAK25A.2530.04.IK	25	30	17	15,7	24	15,1	f ₂ +w/2	4	38,6	34	25A04	220001
RAK25A.3040.04.IK	30	40	18	15,7	24	15,1	f ₂ +w/2	4	38,6	34	25A04	220001
RAK25A.4050.04.IK	40	50	20	15,7	24	15,5	f ₂ +w/2	4	39,2	34	25A04	220001
RAK25A.5065.04.IK	50	65	20	15,7	24	17,1	f ₂ +w/2	4	39	34	25A04	220001
LAK25A.1520.02.IK	15	20	12	15,7	21	15,4	f ₂ +w/2	2	38,6	34	25A02	220002
LAK25A.2025.02.IK	20	25	12	15,7	22	15,4	f ₂ +w/2	2	38,6	34	25A02	220002
LAK25A.2530.02.IK	25	30	13	15,7	23	15,4	f ₂ +w/2	2	38,6	34	25A02	220002
LAK25A.2025.03.IK	20	25	14	15,7	24	14,9	f ₂ +w/2	3	38,6	34	25A03	220002
LAK25A.2530.03.IK	25	30	15	15,7	25	14,9	f ₂ +w/2	3	38,6	34	25A03	220002
LAK25A.3040.03.IK	30	40	16	15,7	23	14,9	f ₂ +w/2	3	38,6	34	25A03	220002
LAK25A.4050.03.IK	40	50	18	15,7	24	14,9	f ₂ +w/2	3	38,6	34	25A03	220002
LAK25A.5065.03.IK	50	65	18	15,7	22	15,4	f ₂ +w/2	3	39	34	25A03	220002
LAK25A.6580.03.IK	65	80	18	15,7	21,5	15,4	f ₂ +w/2	3	39	34	25A03	220002
LAK25A.2025.04.IK	20	25	16	15,7	24	15,1	f ₂ +w/2	4	38,6	34	25A04	220002
LAK25A.2530.04.IK	25	30	17	15,7	24	15,1	f ₂ +w/2	4	38,6	34	25A04	220002
LAK25A.3040.04.IK	30	40	18	15,7	24	15,1	f ₂ +w/2	4	38,6	34	25A04	220002
LAK25A.4050.04.IK	40	50	20	15,7	24	15,1	f ₂ +w/2	4	39,2	34	25A04	220002
LAK25A.5065.04.IK	50	65	18	15,7	22	15,4	f ₂ +w/2	4	39	34	25A04	220002
LAK25A.6580.04.IK	65	80	20	15,7	23,5	17,1	f ₂ +w/2	4	39	34	25A04	220002

Pièces Détachées

Ricambi

Cassette Cartuccia	Vis de serrage Vite di serraggio	Tournevis TORX PLUS® Cacciavite TORX PLUS®
R/LAK25A...	5.13T20P	T20PQ

L'arête de coupe doit être réglé de 0,3 mm au-dessus de la hauteur de centre
Il tagliente deve essere posizionato 0,3 mm sopra centro

w voir plaquettes amovibles
w vd. inserti

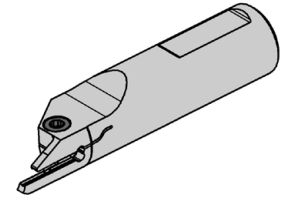
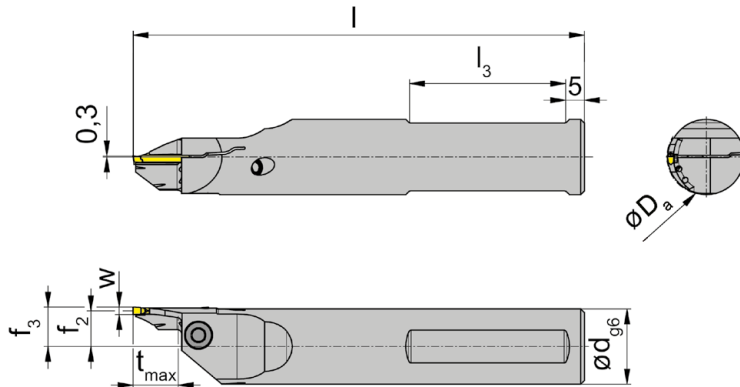
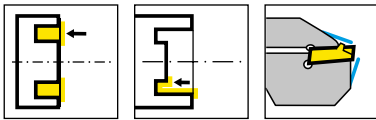

L = version à gauche représentée
L = versione sinistra come in figura

R = version à droite
R = versione destra a specchio

N° de commande Codice prodotto	d	l	l ₃	f ₃	f ₂	t _{max}	D _{a min}	D _{a max}	HWS
RIB25A.20.2025.02.IK	20	120	55	f ₂ +w/2	9,5	12	20	25	25A02
RIB25A.20.2530.02.IK	20	120	55	f ₂ +w/2	9,5	13	25	30	25A02
RIB25A.20.2025.03.IK	20	120	55	f ₂ +w/2	9	14	20	25	25A03
RIB25A.20.2530.03.IK	20	120	55	f ₂ +w/2	9	15	25	30	25A03
RIB25A.20.3040.03.IK	20	120	55	f ₂ +w/2	9	16	30	40	25A03
RIB25A.20.4050.03.IK	20	120	55	f ₂ +w/2	9	18	40	50	25A03
RIB25A.20.6580.03.IK	20	120	55	f ₂ +w/2	9	18	65	80	25A03
RIB25A.20.2025.04.IK	20	120	55	f ₂ +w/2	8,5	16	20	25	25A04
RIB25A.20.2530.04.IK	20	120	55	f ₂ +w/2	8,5	17	25	30	25A04
RIB25A.20.3040.04.IK	20	120	55	f ₂ +w/2	8,5	18	30	40	25A04
RIB25A.20.4050.04.IK	20	120	55	f ₂ +w/2	8,5	20	40	50	25A04
RIB25A.20.5065.04.IK	20	120	55	f ₂ +w/2	8,5	20	65	80	25A04
RIB25A.20.6580.04.IK	20	120	55	f ₂ +w/2	8,5	20	65	80	25A04
LIB25A.20.2025.02.IK	20	120	55	f ₂ +w/2	9,5	12	20	25	25A02
LIB25A.20.2530.02.IK	20	120	55	f ₂ +w/2	9,5	13	25	30	25A02
LIB25A.20.2025.03.IK	20	120	55	f ₂ +w/2	9	14	20	25	25A03
LIB25A.20.2530.03.IK	20	120	55	f ₂ +w/2	9	15	25	30	25A03
LIB25A.20.3040.03.IK	20	120	55	f ₂ +w/2	9	16	30	40	25A03
LIB25A.20.4050.03.IK	20	120	55	f ₂ +w/2	9	18	40	50	25A03
LIB25A.20.5065.03.IK	20	120	55	f ₂ +w/2	9	18	50	65	25A03
LIB25A.20.2025.04.IK	20	120	55	f ₂ +w/2	8,5	16	20	25	25A04
LIB25A.20.2530.04.IK	20	120	55	f ₂ +w/2	8,5	17	25	30	25A04
LIB25A.20.3040.04.IK	20	120	55	f ₂ +w/2	8,5	18	30	40	25A04
LIB25A.20.4050.04.IK	20	120	55	f ₂ +w/2	8,5	20	40	50	25A04
LIB25A.20.5065.04.IK	20	120	55	f ₂ +w/2	8,5	20	50	65	25A04

L'arête de coupe doit être réglé de 0,3 mm au-dessus de la hauteur de centre
Il tagliente deve essere posizionato 0,3 mm sopra centro

w voir plaquettes amovibles
w vd. inserti

Pièces Détachées

Ricambi

Porte outils Portainsero	Vis de serrage Vite di serraggio	Tournevis TORX PLUS® Cacciavite TORX PLUS®
R/LIB25A.20...	5.13T20EP	T20PQ
R/LIB25A.20...03	5.17T20P	T20PQ
R/LIB25A.20.6580.04.IK	5.13T20P	T20PQ



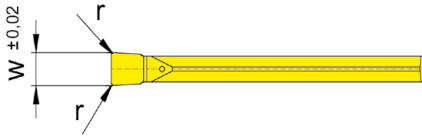
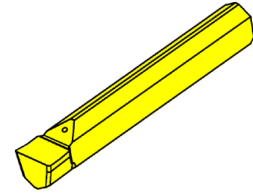
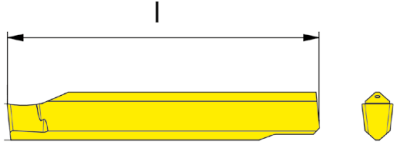
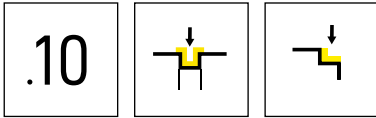

▲ en stock
a stock

Δ 4 semaines
4 settimane

Nuance
Leghe

N° de commande Codice prodotto	w	r	l	HIS	Nuance Leghe			
					EG55	IG35	TH35	
S15A.0200.12	2	0,2	20	25A02	▲	▲	▲	
S15A.0300.12	3	0,2	21	25A03	▲	▲	▲	
S15A.0400.12	4	0,2	24	25A04	▲	▲	▲	
					P	●	-	●
					M	○	●	●
					K	○	-	●
					N	-	-	●
					S	-	●	●
					H	-	-	-

T

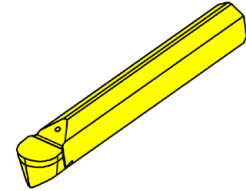
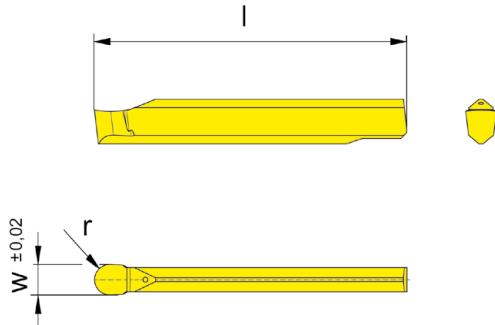
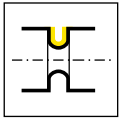

Nuance
Leghe

▲ en stock
a stock

Δ 4 semaines
4 settimane

N° de commande Codice prodotto	w	l	r	HIS	Nuance Leghe		
					EG55	IG35	TH35
S15A.0200.10.10	2	20	1	25A02	▲	▲	▲
S15A.0300.10.15	3	21	1,5	25A03	▲	▲	▲
S15A.0400.10.20	4	24	2	25A04	▲	▲	▲
P	●	-	●				
M	○	●	●				
K	○	-	●				
N	-	-	●				
S	-	●	●				
H	-	-	-				



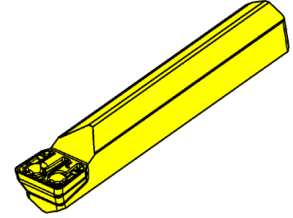
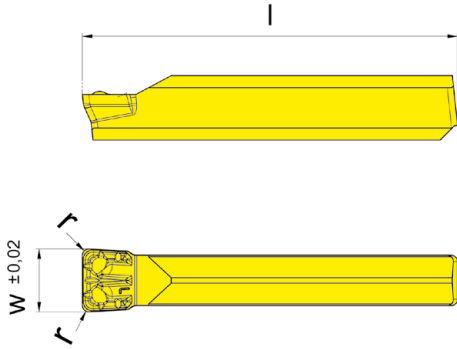
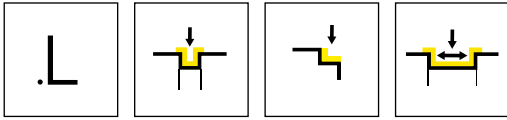

Nuance
Leghe

▲ en stock
a stock

Δ 4 semaines
4 settimane

N° de commande Codice prodotto	w	r	l	HIS	Nuance		
					AS45	EG55	IG65
S15A.0300.L2	3	0,2	24	25A03	▲	▲	▲
S15A.0400.L4	4	0,4	24	25A04	▲	▲	▲
					P ●	●	●
					M ●	○	●
					K ●	○	-
					N ○	-	-
					S ●	-	○
					H -	-	-

T

.10

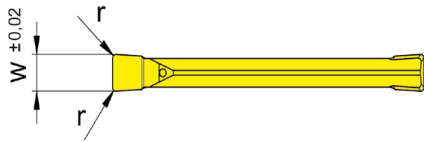
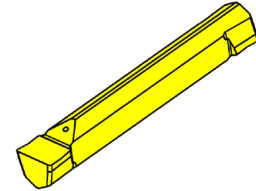
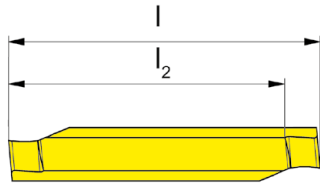
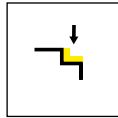
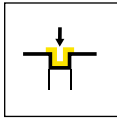

Nuance
Leghe

▲ en stock
a stock

Δ 4 semaines
4 settimane

N° de commande Codice prodotto	w	r	l	l ₂	HIS	Nuance Leghe		
						EG55	IG35	TH35
S25A.0200.12	2	0,2	20	17	25A02	▲	▲	▲
S25A.0300.12	3	0,2	21	18	25A03	▲	▲	▲
S25A.0400.12	4	0,2	24	20,5	25A04	▲	▲	▲
P	●	-	●					
M	○	●	●					
K	○	-	●					
N	-	-	●					
S	-	●	●					
H	-	-	-					



Plaquette amovible

Inserto

S25A

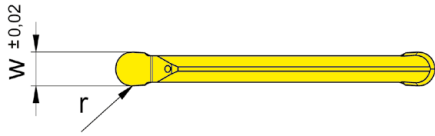
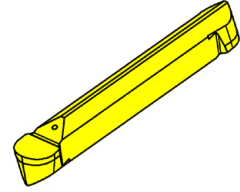
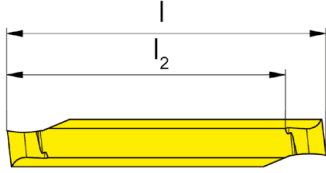
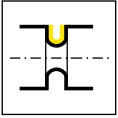

Nuance
Leghe

▲ en stock
a stock

Δ 4 semaines
4 settimane

N° de commande Codice prodotto	w	l	r	l ₂	HIS	Nuance			
						EG55	IG35	TH35	
S25A.0200.10.10	2	20	1	17	25A02	▲	▲	▲	
S25A.0300.10.15	3	21	1,5	18	25A03	▲	▲	▲	
S25A.0400.10.20	4	24	2	20,5	25A04	▲	▲	▲	
						P	●	-	●
						M	○	●	●
						K	○	-	●
						N	-	-	●
						S	-	●	●
						H	-	-	-

T

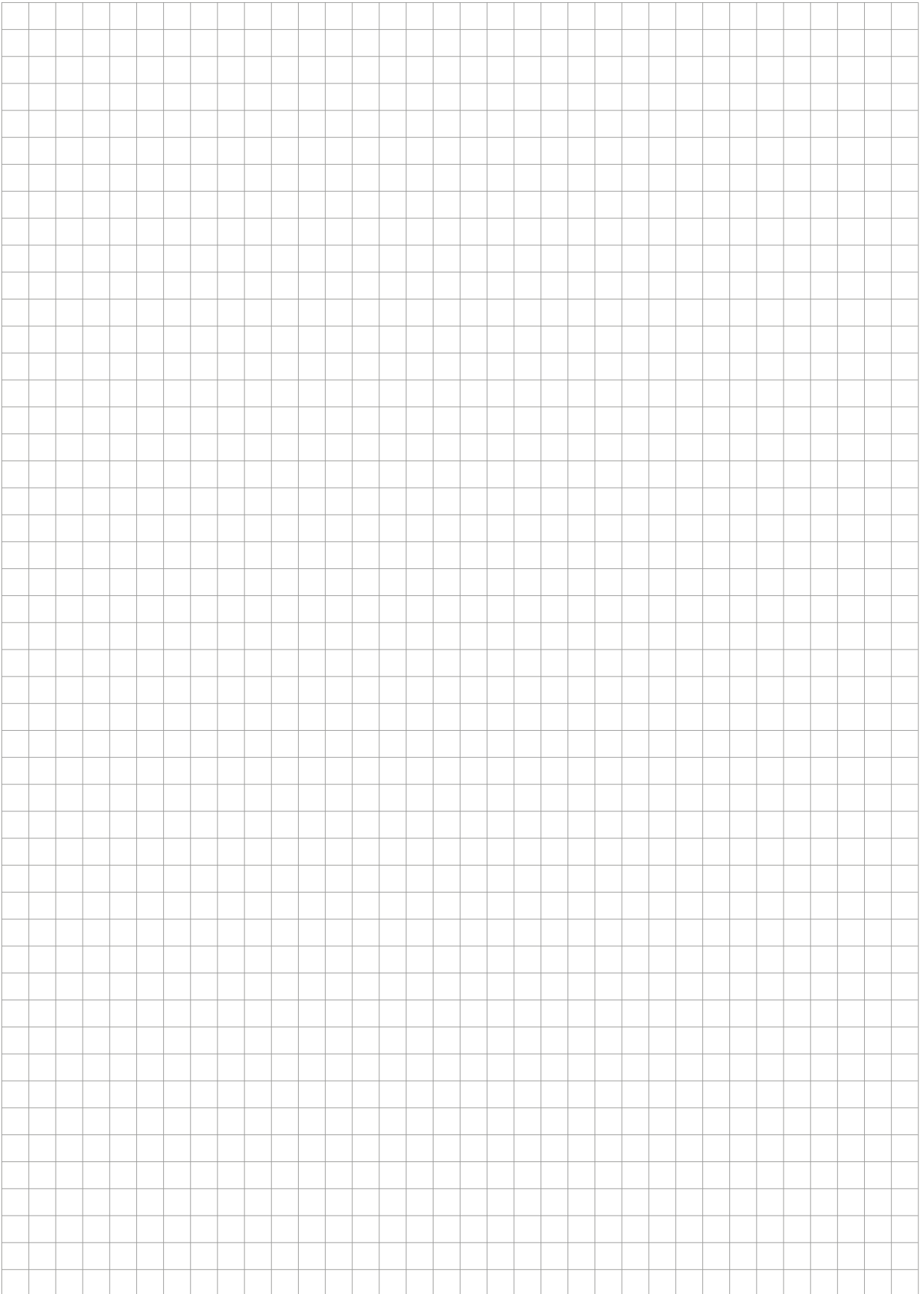

Gorge frontale

Gole assiali



Base de support
Attacco Base
220/B224

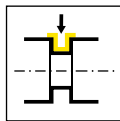

Page/Pag.
550-551

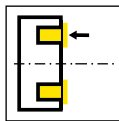

Page/Pag.
552

Cassette
Cartuccia
LAK224/RAK224/
LIK224/RIK224

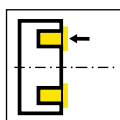

Page/Pag.
553-560

Plaquette amovibile
Inserto
S224

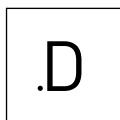

Page/Pag.
561

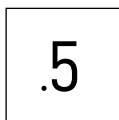

Page/Pag.
562

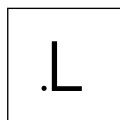

Page/Pag.
563

T