

114



T

Porte outils et plaquettes

Largeur de gorge 1 - 3 mm

Portainserito e inserti

Larghezza della gola 1 - 3 mm

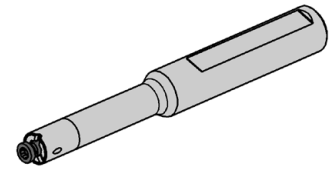
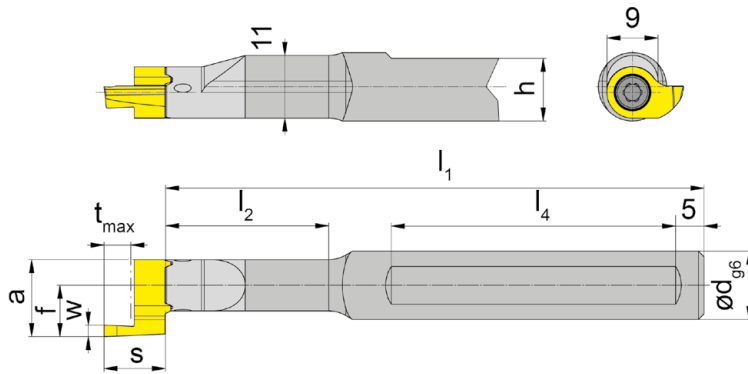
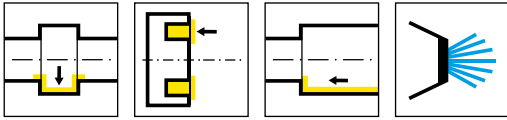

Illustration de coupe à droite représentée
Figura = taglio destro

N° de commande Codice prodotto	d	l ₁	l ₂	h	l ₄	HWS
B114.0012.00	12	69,7	14,2	11	40	311090R • 311090L
B114.0012.01	12	94,7	28,7	11	50	311090R • 311090L
B114.0012.02	12	104,7	39,7	11	50	311090R • 311090L
B114.0012.03	12	124,7	58,7	11	50	311090R • 311090L
B114.0016.00	16	74,7	14,2	15	40	311090R • 311090L
B114.0016.01	16	94,7	28,7	15	50	311090R • 311090L
B114.0016.02	16	104,7	39,7	15	50	311090R • 311090L
B114.0016.03	16	124,7	58,7	15	50	311090R • 311090L

w, a, s, tmax et f voir plaquettes
w, a, s, tmax, f vd. Inserti

Pièces Détachées

Ricambi

Porte outils Portainsero	Vis de serrage Vite di serraggio	Tournevis TORX PLUS® Cacciavite TORX PLUS®
B114...	4.12T15EP	T15PQ

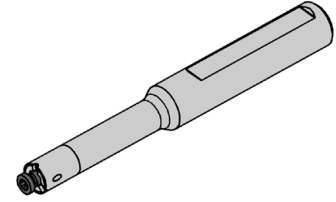
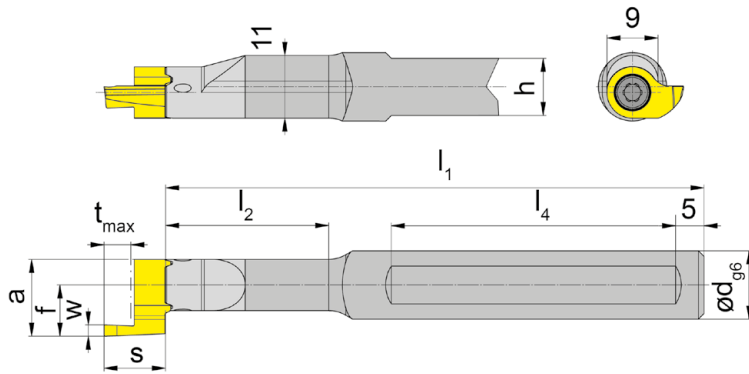
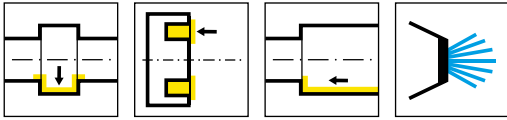

Illustration de coupe à droite représentée
Figura = taglio destro

N° de commande Codice prodotto	d	l ₁	l ₂	h	l ₄	HWS
B114.0012.2.00	12	69,7	14,2	11	40	311090R • 311090L
B114.0012.2.01	12	94,7	28,7	11	50	311090R • 311090L
B114.0012.2.02	12	104,7	39,7	11	50	311090R • 311090L
B114.0012.2.03	12	124,7	58,7	11	50	311090R • 311090L
B114.0016.2.00	16	74,7	14,2	14	40	311090R • 311090L
B114.0016.2.01	16	94,7	28,7	14	50	311090R • 311090L
B114.0016.2.02	16	104,7	39,7	14	50	311090R • 311090L
B114.0016.2.03	16	124,7	58,7	14	50	311090R • 311090L

w, a, s, tmax et f voir plaquettes
w, a, s, tmax, f vd. Inserti

Pièces Détachées

Ricambi

Porte outils Portainsero	Vis de serrage Vite di serraggio	Tournevis TORX PLUS® Cacciavite TORX PLUS®
B114...	4.12T15EP	T15PQ



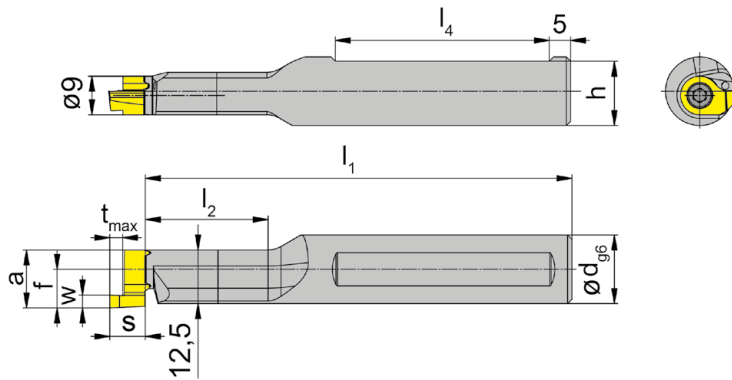
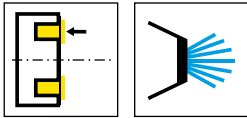

Illustration de coupe à droite représentée
Figura = taglio destro

N° de commande Codice prodotto	d	l_1	l_2	h	l_4	HWS
RBA114.0016.01	16	99,7	28,7	15	50	311090R • 311090L
RBA114.0016.02	16	109,7	39,7	15	50	311090R • 311090L
LBA114.0016.01	16	99,7	28,7	15	50	311090R • 311090L
LBA114.0016.02	16	109,7	39,7	15	50	311090R • 311090L

w, a, s, tmax et f voir plaquettes
w, a, s, tmax, f vd. Inserti

Pièces Détachées

Ricambi

Porte outils Portainsero	Vis de serrage Vite di serraggio	Tournevis TORX PLUS® Cacciavite TORX PLUS®
R/LBA114...	4.12T15EP	T15PQ

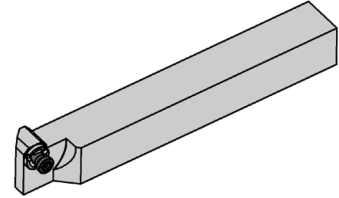
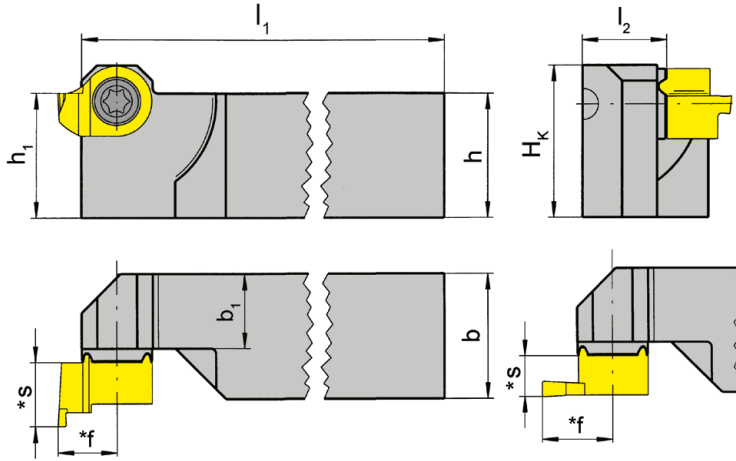
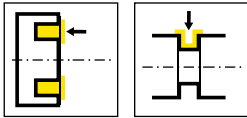

R = version à droite représentée
R = versione destra come in figura

L = version à gauche
L = versione sinistra a specchio

N° de commande Codice prodotto	h	b	l ₁	l ₂	h ₁	b ₁	H _k	HWS
RHC114.1212.01	12	12	122	11,2	12	9,5	15,6	311090R • 311090L
RHC114.1616.01	16	16	122	11,2	16	9,5	19,6	311090R • 311090L
RHC114.2020.01	20	20	122	15,2	20	13,5	23,6	311090R • 311090L
RHC114.2525.01	25	25	147	20,2	25	18,5	28,6	311090R • 311090L
LHC114.1212.01	12	12	122	11,2	12	9,5	15,6	311090R • 311090L
LHC114.1616.01	16	16	122	11,2	16	9,5	19,6	311090R • 311090L
LHC114.2020.01	20	20	122	15,2	20	13,5	23,6	311090R • 311090L
LHC114.2525.01	25	25	147	20,2	25	18,5	28,6	311090R • 311090L

* voir plaquettes
* vd. inserti

Porte outils droite sont utilisable pour les plaquettes à gauche. Porte outils gauche sont utilisable pour les plaquettes à droite.
Utilizzare portainsero destro su inserto sinistro. Utilizzare portainsero sinistro su inserto destro.

Pièces Détachées

Ricambi

Porte outils Portainsero	Vis de serrage Vite di serraggio	Tournevis TORX PLUS® Cacciavite TORX PLUS®
R/LHC114...	4.12T15EP	T15PQ



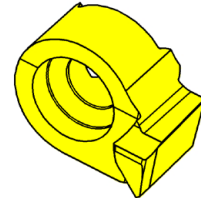
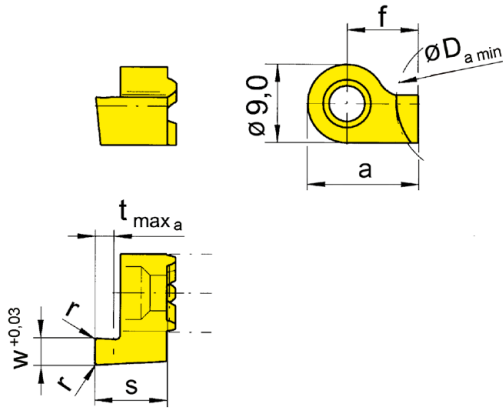
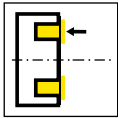

R = version à droite représentée
R = versione destra come in figura

L = version à gauche
L = versione sinistra a specchio

▲ en stock
▲ a stock

Nuance
Leghe
Δ 4 semaines
4 settimane

N° de commande Codice prodotto	w	s	f	a	r	t _{max a}	D _{a min}	HIS	EG55	TN35
R114.1210.00	1	8,3	7,5	12	-	1,5	12	311090R	▲	▲
R114.1215.00	1,5	8,3	7,5	12	0,2	2,5	12	311090R	▲	▲
R114.1220.00	2	8,3	7,5	12	0,2	3	12	311090R	▲	▲
R114.1225.00	2,5	8,3	7,5	12	0,2	3	12	311090R	▲	▲
R114.1230.00	3	8,3	7,5	12	0,2	3	12	311090R	▲	▲
R114.1220.5.00	2	10,8	7,5	12	0,2	5	12	311090R	▲	▲
R114.1225.5.00	2,5	10,8	7,5	12	0,2	5	12	311090R	▲	▲
R114.1230.6.00	3	11,8	7,5	12	0,2	6	12	311090R	▲	▲
L114.1210.00	1	8,3	7,5	12	-	1,5	12	311090L	▲	▲
L114.1215.00	1,5	8,3	7,5	12	0,2	2,5	12	311090L	▲	▲
L114.1220.00	2	8,3	7,5	12	0,2	3	12	311090L	▲	▲
L114.1225.00	2,5	8,3	7,5	12	0,2	3	12	311090L	▲	▲
L114.1230.00	3	8,3	7,5	12	0,2	3	12	311090L	▲	▲
L114.1220.5.00	2	10,8	7,5	12	0,2	5	12	311090L	▲	▲
L114.1225.5.00	2,5	10,8	7,5	12	0,2	5	12	311090L	▲	▲
L114.1230.6.00	3	11,8	7,5	12	0,2	6	12	311090L	▲	▲

Usinage frontal le long d'un axe!
Lavorazione oltre l'asse del pezzo

R = rotation antihoraire! Utiliser les plaquettes à gorges frontales type 114 sur les porte outils type B114 la cote l1 et l2 doivent être augmentées de 3,0 / 5,5 ou 6,5 mm.

R = rotazione senso antiorario! Utilizzando l'inserto tipo 114 per gole assiali con portainserito B114 le quote l1 e l2 devono essere incrementate di 3,0 / 5,5 o 6,5 mm.

P	●	●
M	○	●
K	○	●
N	-	●
S	-	●
H	-	-

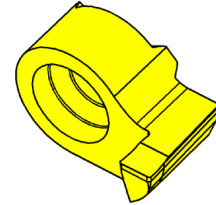
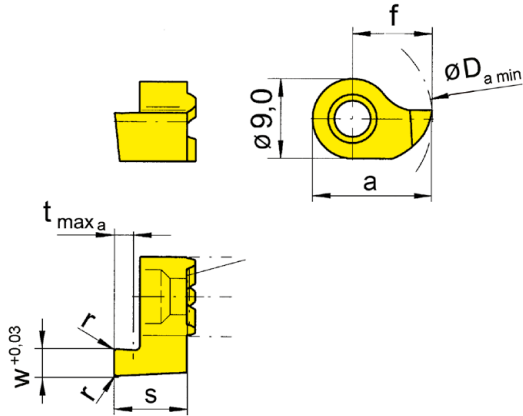
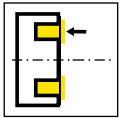

R = version à droite représentée
R = versione destra come in figura

L = version à gauche
L = versione sinistra a specchio

▲ en stock
a stock

Nuance
Leghe
Δ 4 semaines
4 settimane

N° de commande Codice prodotto	w	s	f	a	r	t _{max a}	D _{a min}	HIS	MG12	EG55	TF45	TN35
R114.1410.00	1	8,3	9	13,5	-	1,5	14	311090R	Δ	▲		▲
R114.1415.00	1,5	8,3	9	13,5	0,2	2,5	14	311090R		▲		▲
R114.1420.00	2	8,3	9	13,5	0,2	3	14	311090R		▲		▲
R114.1425.00	2,5	8,3	9	13,5	0,2	3	14	311090R		▲		▲
R114.1430.00	3	8,3	9	13,5	0,2	3	14	311090R	▲	▲		▲
R114.1420.5.00	2	10,8	9	13,5	0,2	5	14	311090R		▲		▲
R114.1425.5.00	2,5	10,8	9	13,5	0,2	5	14	311090R		▲		▲
R114.1430.6.00	3	11,8	9	13,5	0,2	6	14	311090R		▲		▲
L114.1410.00	1	8,3	9	13,5	-	1,5	14	311090L	Δ	▲		▲
L114.1415.00	1,5	8,3	9	13,5	0,2	2,5	14	311090L		▲		▲
L114.1420.00	2	8,3	9	13,5	0,2	3	14	311090L		▲		▲
L114.1425.00	2,5	8,3	9	13,5	0,2	3	14	311090L		▲		▲
L114.1430.00	3	8,3	9	13,5	0,2	3	14	311090L	Δ			▲
L114.1420.5.00	2	10,8	9	13,5	0,2	5	14	311090L		▲		▲
L114.1425.5.00	2,5	10,8	9	13,5	0,2	5	14	311090L		▲		▲
L114.1430.6.00	3	11,8	9	13,5	0,2	6	14	311090L		▲		▲
P	o	•	•	•								
M	-	o	•	•								
K	-	o	•	•								
N	-	-	•	•								
S	-	-	•	•								
H	-	-	-	-								

Usinage frontal!

Lavorazione a cavallo del pezzo

R = rotation horaire! Utiliser les plaquettes à gorges frontales type 114 sur les porte outils type B114 la cote l1 et l2 doivent être augmentées de 3,0 / 5,5 ou 6,5 mm.

R = rotazione senso orario! Utilizzando l'inserto tipo 114 per gole assiali con portainsero B114 le quote l1 e l2 devono essere incrementate di 3,0 / 5,5 o 6,5 mm.



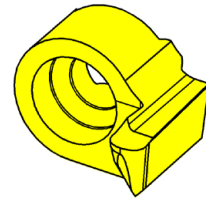
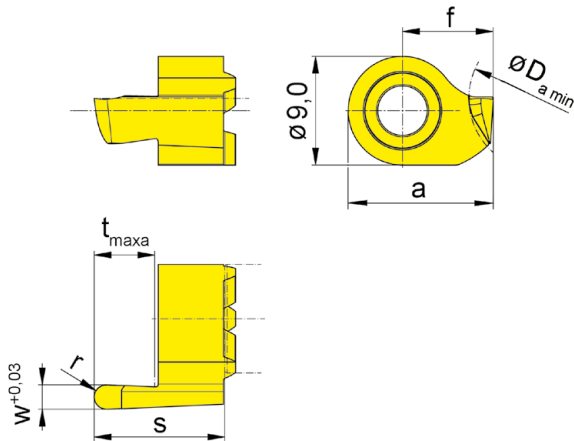
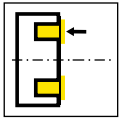

R = version à droite représentée
R = versione destra come in figura

L = version à gauche
L = versione sinistra a specchio

▲ en stock
a stock

Nuance
Leghe
Δ 4 semaines
4 settimane

N° de commande Codice prodotto	w	s	f	a	r	t _{max a}	D _{a min}	HIS	EG55	TN35
R114.1220.5.10	2	10,8	7,5	12	1	5	12	311090R	▲	▲
R114.1225.5.12	2,5	10,8	7,5	12	1,25	5	12	311090R	▲	▲
R114.1230.6.15	3	11,8	7,5	12	1,5	6	12	311090R	▲	▲
L114.1220.5.10	2	10,8	7,5	12	1	5	12	311090L	▲	▲
L114.1225.5.12	2,5	10,8	7,5	12	1,25	5	12	311090L	▲	▲
L114.1230.6.15	3	11,8	7,5	12	1,5	6	12	311090L	▲	▲

Rayon complet Usinage frontal le long d'un axe!
Raggio completo Lavorazione oltre l'asse del pezzo

R = rotation anti horaire! Utiliser les plaquettes à gorges frontales type 114 sur les porte outils type B114 la cote l1 et l2 doivent êtres augmentées de 5,5 ou 6,5 mm.

R = rotazione anti-oraria! Utilizzando l'inserto per gole assiali tipo 114 sul portainsero tipo B114, la dimensione l1 e l2 aumenteranno di 5,5 o 6,5 mm.

P	●	●
M	○	●
K	○	●
N	-	●
S	-	●
H	-	-

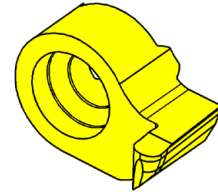
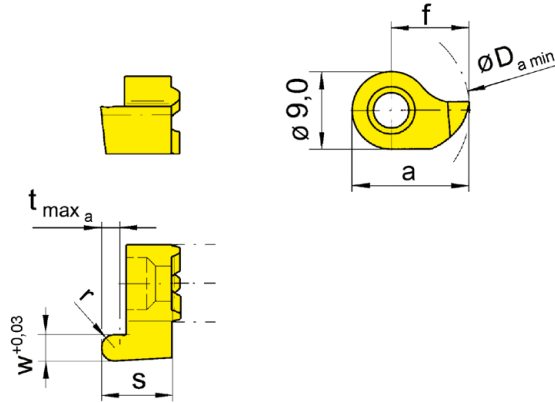
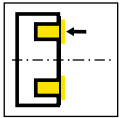

R = version à droite représentée
R = versione destra come in figura

L = version à gauche
L = versione sinistra a specchio

▲ en stock
a stock

Nuance
Leghe
Δ 4 semaines
4 settimane

N° de commande Codice prodotto	w	s	f	a	r	t _{max a}	D _{a min}	HIS	EG55	TN35
R114.1410.05	1	8,3	9	13,5	0,5	1,5	14	311090R	▲	▲
R114.1416.08	1,6	8,3	9	13,5	0,8	2,5	14	311090R	▲	▲
R114.1420.10	2	8,3	9	13,5	1	3	14	311090R	▲	▲
R114.1425.12	2,5	8,3	9	13,5	1,25	3	14	311090R	▲	▲
R114.1430.15	3	8,3	9	13,5	1,5	3	14	311090R	▲	▲
L114.1410.05	1	8,3	9	13,5	0,5	1,5	14	311090L	▲	▲
L114.1416.08	1,6	8,3	9	13,5	0,8	2,5	14	311090L	▲	▲
L114.1420.10	2	8,3	9	13,5	1	3	14	311090L	▲	▲
L114.1425.12	2,5	8,3	9	13,5	1,25	3	14	311090L	▲	▲
L114.1430.15	3	8,3	9	13,5	1,5	3	14	311090L	Δ	▲

Rayon complet **Usinage frontal!**

Raggio completo Lavorazione a cavallo del pezzo

R = rotation horaire! Utiliser les plaquettes à gorges frontales type 114 sur les porte outils type B114 la cote l1 et l2 doivent être augmentées de 3,0 mm.

R = rotazione senso orario! Utilizzando l'inserto tipo 114 per gole assiali con portainsero B114 le quote l1 e l2 devono essere incrementate di 3,0 mm.

P	●	●
M	○	●
K	○	●
N	-	●
S	-	●
H	-	-



Gorge frontale

Gole assiali



Porte outils
Portainsero
H25A/IB25A

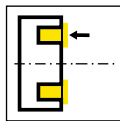

Page/Pag.
538-539, 541

Cassette
Cartuccia
AK25A

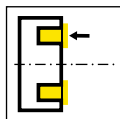

Page/Pag.
540

Plaquette
Inserto
S15A

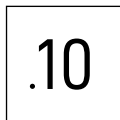

Page/Pag.
542

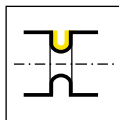

Page/Pag.
543

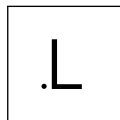

Page/Pag.
544

Plaquette amovibile
Inserto
S25A

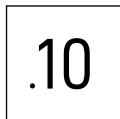

Page/Pag.
545

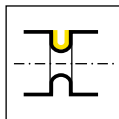

Page/Pag.
546

T