

M406/M409



**Fraise pour rainure
en „T“ avec plaquette
interchangeable**

Diamètre de coupe 25-50 mm

**Fresatura di cave
a „T“ con inserti
intercambiabili**

Diametro Ds 25-50 mm

J

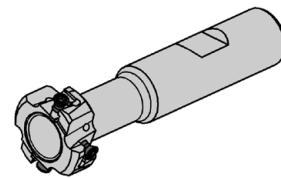
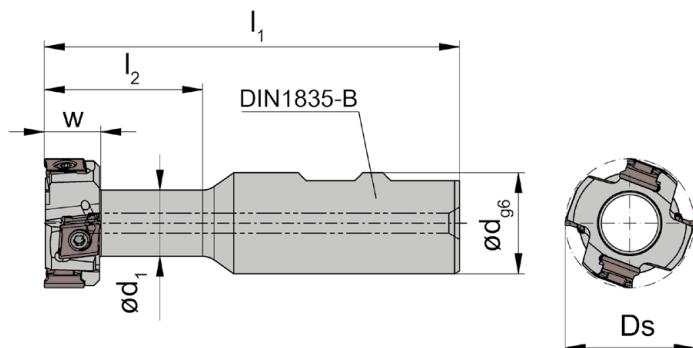
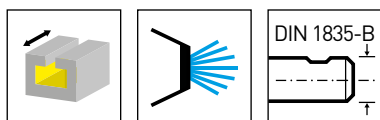

Illustration de coupe à droite représentée

Figura = taglio destro

N° de commande Codice prodotto	Z	Z _{eff}	Ds	d	l ₁	l ₂	d ₁	w	a	n _{max}	Plaquette à droite Inserto destro	Plaquette à gauche Inserto sinistro	HWS
M406.025.11.D16.1.02.B	4	2	25	16	83	31	12,4	11	12,9	19000	2x R406.063.U..	2x L406.063.U..	40600R • 40600L

Pour Ø 25 mm 2 plats serrage
da Ø 25 mm 2 piatti di serraggio

J

Pièces Détachées

Ricambi

Fraise Fresa	Vis de serrage Vite di serraggio	Tournevis TORX PLUS® Cacciavite TORX PLUS®
M406.025.11.D16.1.02.B	030.2608.T8P	T8PL

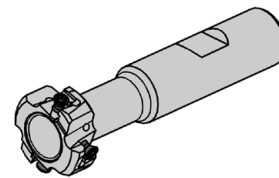
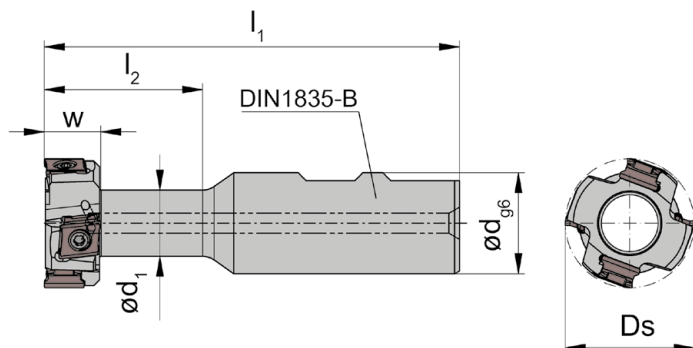
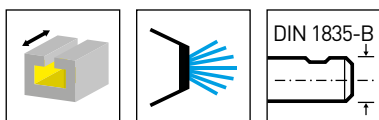

Illustration de coupe à droite représentée

Figura = taglio destro

N° de commande Codice prodotto	Z	Z _{eff}	Ds	d	l ₁	l ₂	d ₁	w	a	n _{max}	Plaquette à droite Inserto destro	Plaquette à gauche Inserto sinistro	HWS
M409.032.14.D25.1.02.B	4	2	32	25	103	39	16,4	14	16,9	15600	2x R409.093.U..	2x L409.093.U..	40900R • 40900L
M409.040.18.D25.1.02.B	4	2	40	25	109	48	20,4	18	20,9	13900	2x R409.093.U..	2x L409.093.U..	40900R • 40900L
M409.050.22.D32.1.02.B	6	2	50	32	125	59	26,4	22	26,9	12500	4x R409.093.U..	2x L409.093.U..	40900R • 40900L

Pour Ø 25 mm 2 plats serrage
da Ø 25 mm 2 piatti di serraggio

Pièces Détachées

Ricambi

Fraise Fresa	Vis de serrage Vite di serraggio	Tournevis TORX PLUS® Cacciavite TORX PLUS®
M409...	030.3511.T10P	T10PL

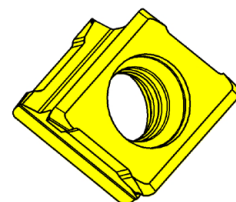
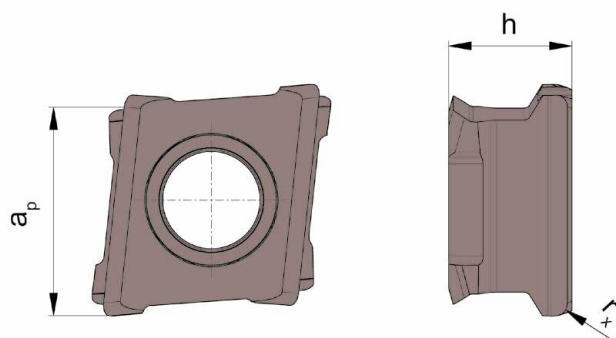
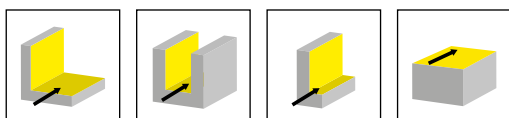

▲ en stock
a stock

△ 4 semaines
4 settimane

Nuance
Leghe

N° de commande Codice prodotto	a _p	h	r _x	HIS	AS46	AS4B
R406.063.U.02	6,3	3,85	0,2	40600R	△	▲
R406.063.U.04	6,3	3,85	0,4	40600R	▲	▲
R406.063.U.08	6,3	3,85	0,8	40600R	▲	▲
L406.063.U.02	6,3	3,85	0,2	40600L	△	▲
L406.063.U.04	6,3	3,85	0,4	40600L	▲	▲
L406.063.U.08	6,3	3,85	0,8	40600L	▲	▲

avec 4 arêtes de coupe utilisables
con 4 taglianti

P	o	•
M	o	•
K	•	•
N	o	o
S	o	•
H	-	-

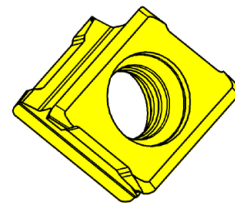
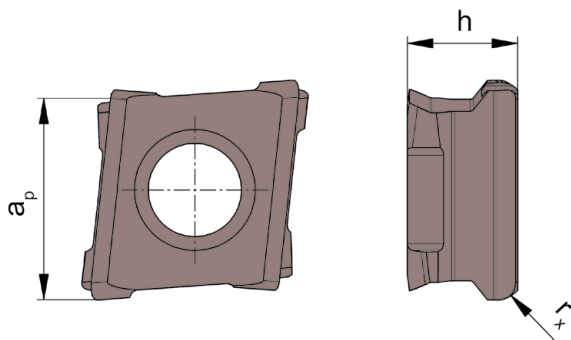
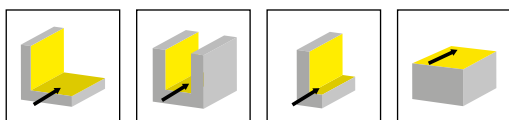

Nuance
Leghe

▲ en stock
a stock

Δ 4 semaines
4 settimane

N° de commande Codice prodotto	a _p	h	r _x	HIS	Nuance	
					AS46	AS4B
R409.093.U.04	9,3	5,2	0,4	40900R	▲	▲
R409.093.U.08	9,3	5,2	0,8	40900R	▲	▲
R409.093.U.12	9,3	5,2	1,2	40900R	▲	▲
L409.093.U.04	9,3	5,2	0,4	40900L	▲	▲
L409.093.U.08	9,3	5,2	0,8	40900L	▲	▲
L409.093.U.12	9,3	5,2	1,2	40900L	▲	▲
					P	o •
					M	o •
					K	• •
					N	o o
					S	o •
					H	- -

avec 4 arêtes de coupe utilisables
con 4 taglianti



Applications Technologiques

Nozioni tecniche

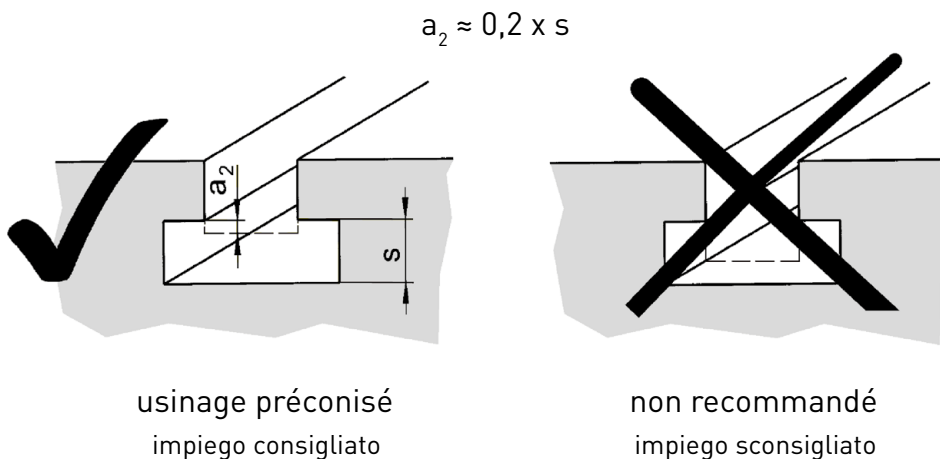

Conditions de coupe

Parametri di taglio

Fraisage de rainure en „T“ Ø25 / Ø32 mm

Fresatura di cava a „T“

Matières usinées Materiale di lavorare	Matières de coupe Leghe dei taglienti	v_c (m/min)	f_z (mm)
Acier pour traitement thermique Acciaio da bonifca e tempra	AS4B	120 - 160	0,07 - 0,14
Fonte grise Ghise	AS4B	100 - 160	0,07 - 0,14

Fraisage de rainure en „T“ Ø40 / Ø50 mm

Fresatura di cava a „T“

Matières usinées Materiale di lavorare	Matières de coupe Leghe dei taglienti	v_c (m/min)	f_z (mm)
Acier pour traitement thermique Acciaio da bonifca e tempra	AS4B	60 - 90	0,06 - 0,08
Fonte grise Ghise	AS4B	90 - 140	0,06 - 0,08