

# M311



**Fraise pour rainure  
en „T“ avec plaquette  
interchangeable**

de Diamètre de coupe 17 mm

**Fresatura di cave  
a „T“ con inserti  
intercambiabili**

da Diametro 17 mm

J

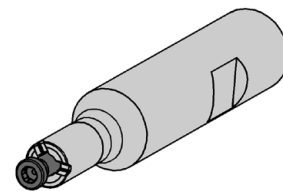
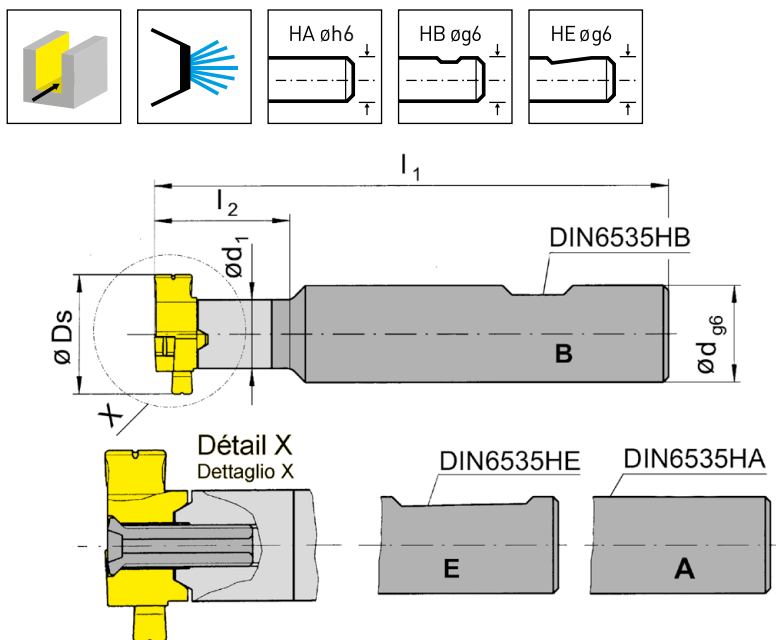

Illustration de coupe à droite représentée

Figura = taglio destro

N° de commande Codice prodotto	d	l <sub>1</sub>	l <sub>2</sub>	d <sub>1</sub>	Forme Forma	HWS
<b>M311.0016.00A</b>	16	90	25	9	A	311090R
<b>M311.0016.00B</b>	16	90	25	9	B	311090R
<b>M311.0016.00E</b>	16	90	25	9	E	311090R

Ds voir plaquettes

Ds vd. inserti

J

**Pièces Détachées**

Ricambi

Corps de fraise Corpo fresa	Vis de serrage Vite di serraggio	Tournevis TORX PLUS® Cacciavite TORX PLUS®
M311...	<b>4.16T15KP</b>	<b>T15PQ</b>

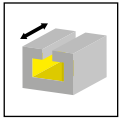

z3

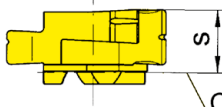
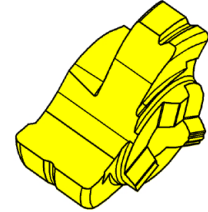
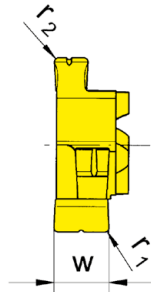
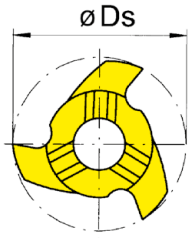

Corps de fraise  
Fresa portainsero

Illustration de coupe à droite représentée  
Figura = taglio destro

Nuance  
Leghe  
▲ en stock  
a stock  
Δ 4 semaines  
4 settimane

N° de commande Codice prodotto	Ds	s	w	r <sub>1</sub>	r <sub>2</sub>	a	HIS	AS45	TI25
311.1016.00	17	7,7	7,2	0,5	0,8	10	311090R	▲	▲

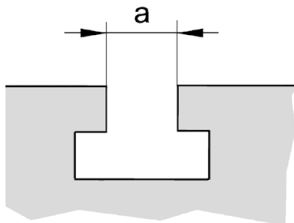

P	●	●
M	●	●
K	●	●
N	○	●
S	●	●
H	-	-

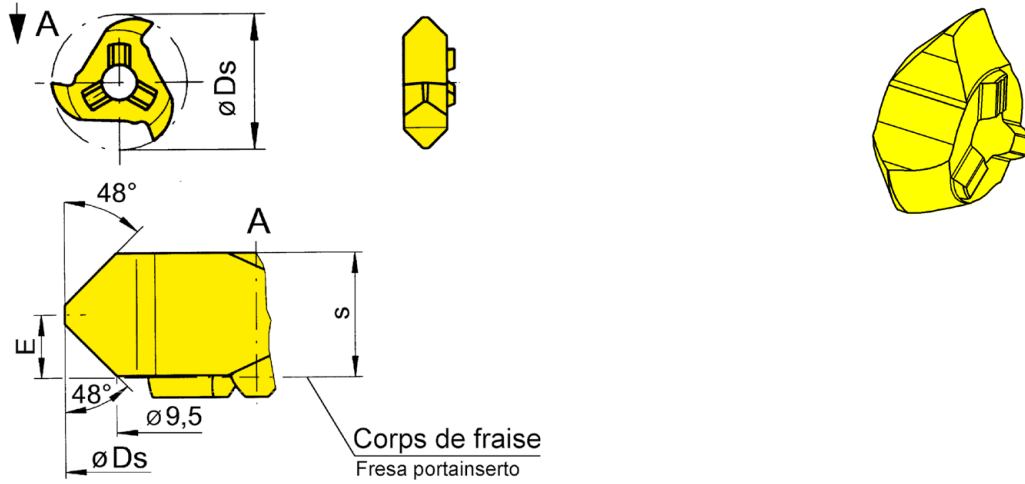
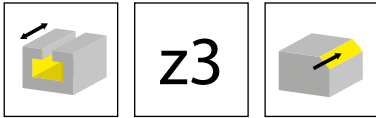

Corps de fraise  
Fresa portainsero

Illustration de coupe à droite représentée  
Figura = taglio destro

▲ en stock  
a stock

Δ 4 semaines  
4 settimane

Nuance  
Leghe

N° de commande Codice prodotto	Ds	E	s	a	HIS	Ti25
311.4216.00	15,8	3	5,95	10	311090R	▲

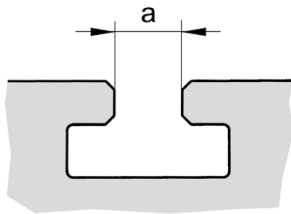

P	●
M	●
K	●
N	●
S	●
H	-

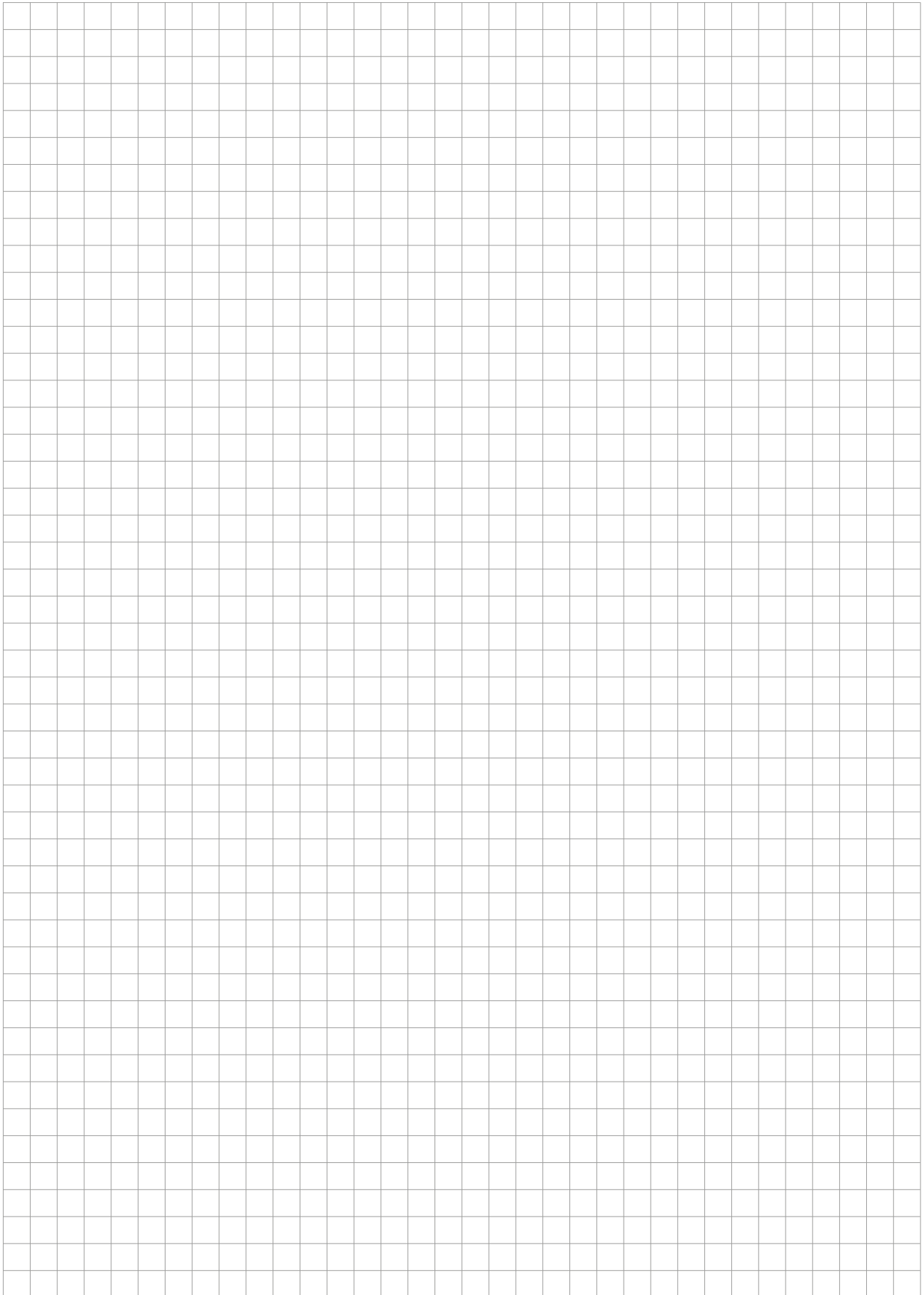

# Fraisage de rainure en „T“

Fresatura di cave a „T“

---

Corps de fraise  
Corpo fresa  
M313

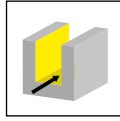

Page/Pag.  
418

Plaquette  
Inserto  
313

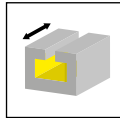

Page/Pag.  
419

# M313



**Fraise pour rainure  
en „T“ avec plaquette  
interchangeable**

de Diamètre de coupe 20 mm

**Fresatura di cave  
a „T“ con inserti  
intercambiabili**

da Diametro 20 mm

**J**

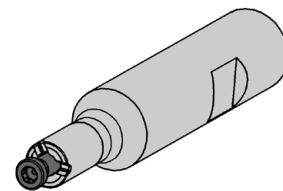
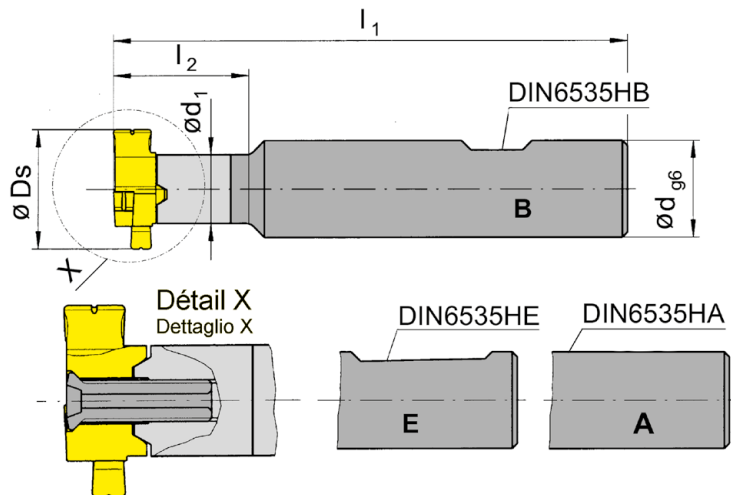
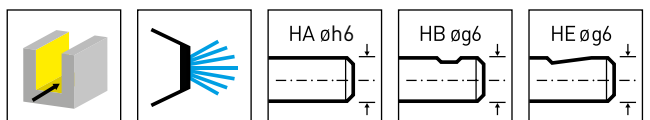

Illustration de coupe à droite représentée

Figura = taglio destro

N° de commande Codice prodotto	d	l <sub>1</sub>	l <sub>2</sub>	d <sub>1</sub>	Forme Forma	HWS
<b>M313.0016.00A</b>	16	93	30	11,5	A	313113R • 313113L
<b>M313.0016.00B</b>	16	93	30	11,5	B	313113R • 313113L
<b>M313.0016.00E</b>	16	93	30	11,5	E	313113R • 313113L

Ds voir plaquettes

Ds vd. inserti



**Pièces Détachées**

Ricambi

<b>Corps de fraise</b> Corpo fresa	<b>Vis de serrage</b> Vite di serraggio	<b>Tournevis TORX PLUS®</b> Cacciavite TORX PLUS®
M313...	<b>5.13T20KP</b>	<b>T20PQ</b>



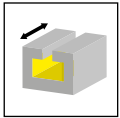

z3

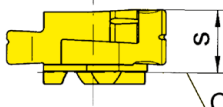
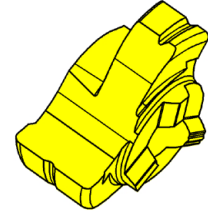
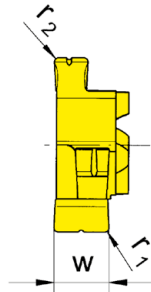
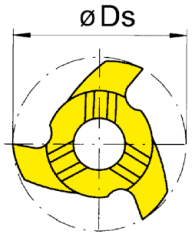

Corps de fraise  
Fresa portainsero

Illustration de coupe à droite représentée  
Figura = taglio destro

Nuance  
Leghe  
▲ en stock  
a stock  
Δ 4 semaines  
4 settimane

N° de commande Codice prodotto	Ds	s	w	r <sub>1</sub>	r <sub>2</sub>	a	HIS	AS45	TI25
313.1219.00	20	8,7	8,2	0,5	0,8	12	313113R	▲	▲
								P ● ●	● ●
								M ● ●	● ●
								K ● ●	● ●
								N ○ ●	● ●
								S ● ●	● ●
								H - -	- -

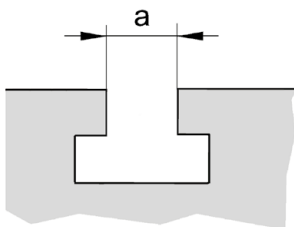

# Fraisage de rainure en „T“

Fresatura di cave a „T“



Corps de fraise  
Corpo fresa  
M328

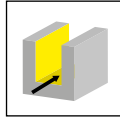

Page/Pag.  
422

Plaquette  
Inserto  
328

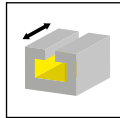

Page/Pag.  
423

Informations techniques  
Informazioni tecniche

Page/Pag.  
424

# M328



**Fraise pour rainure  
en „T“ avec plaquette  
interchangeable**

de Diamètre de coupe  $\varnothing$  24 mm

**Fresatura di cave  
a „T“ con inserti  
intercambiabili**

da Diametro  $\varnothing$  24 mm

**J**

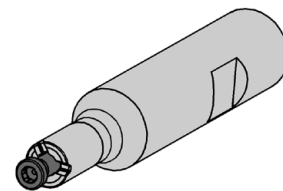
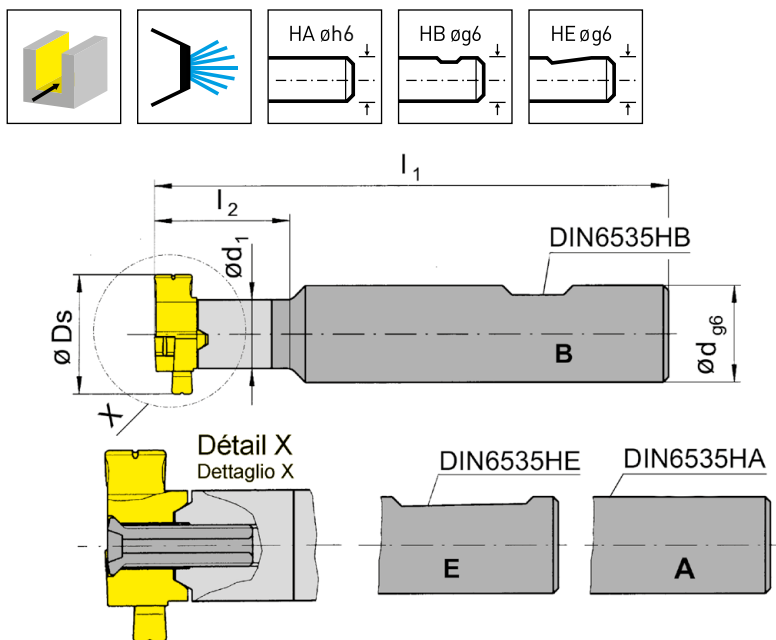

Illustration de coupe à droite représentée

Figura = taglio destro

N° de commande Codice prodotto	d	l <sub>1</sub>	l <sub>2</sub>	d <sub>1</sub>	Forme Forma	HWS
M328.0020.00A	20	104	35	13,5	A	328143R
M328.0020.00B	20	104	35	13,5	B	328143R
M328.0020.00E	20	104	35	13,5	E	328143R

Ds voir plaquettes

Ds vd. inserti

J

### Pièces Détachées

Ricambi

Corps de fraise Corpo fresa	Vis de serrage Vite di serraggio	Tournevis TORX PLUS® Cacciavite TORX PLUS®
M328...	5.13T20KP	T20PQ

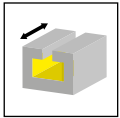

z3

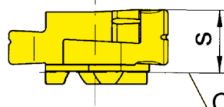
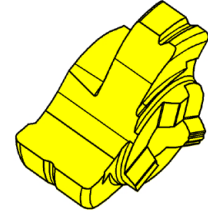
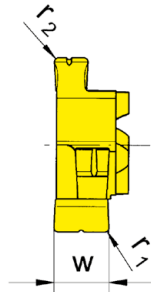
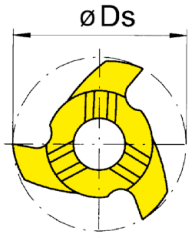

Corps de fraise  
Fresa portainsero

Illustration de coupe à droite représentée  
Figura = taglio destro

Nuance  
Leghe  
▲ en stock  
a stock  
Δ 4 semaines  
4 settimane

N° de commande Codice prodotto	Ds	s	w	r <sub>1</sub>	r <sub>2</sub>	a	HIS	AS45	TI25
328.1423.00	24	9,8	9,2	0,5	1	14	328143R	▲	▲
								P ● ●	● ●
								M ● ●	● ●
								K ● ●	● ●
								N ○ ●	● ●
								S ● ●	● ●
								H - -	- -

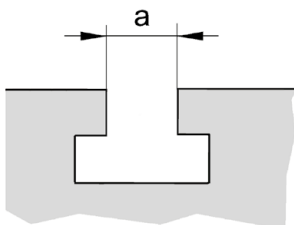

## Applications Technologiques

Nozioni tecniche

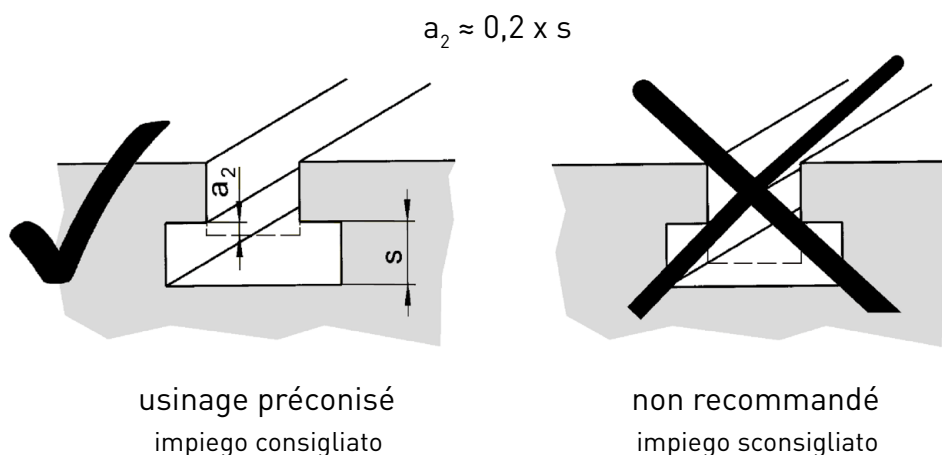

## Conditions de coupe

Parametri di taglio

### Fraisage de rainure en „T“

Fresatura di cava a „T“

Matières usinées Materiale di lavorare	Matières de coupe Leghe dei taglienti	$v_c$ (m/min)	$f_z$ (mm), Z=1 Ds 17 mm	$f_z$ (mm), Z=1 Ds 20-24 mm
Acier au carbone Acciai al carbonio	TI25 / AS45	200 - 300	0,03 - 0,06	0,05 - 0,08
Acier allié Acciai legati	TI25 / AS45	140 - 220	0,02 - 0,04	0,03 - 0,05
Fonte grise Ghise	TI25 / AS45	100 - 160	0,03 - 0,06	0,05 - 0,10

### Chanfreinage de rainure en „T“

Esecuzione smussi cava a „T“

Matières usinées Materiale di lavorare	Matières de coupe Leghe dei taglienti	$v_c$ (m/min)	$f_z$ (mm), Z=3
Acier au carbone Acciai al carbonio	TI25 / AS45	300 - 400	0,10 - 0,13
Acier allié Acciai legati	TI25 / AS45	180 - 300	0,13 - 0,21
Fonte grise Ghise	TI25 / AS45	140 - 240	0,16 - 0,27

Paramètres de coupe seulement valables avec corps carbure antivibratoire (standard).

I dati di taglio sono validi unicamente per l'utilizzo dei nostri portainseri con gambo in metallo duro anti-vibrante.