

# M328



**G**

**Fraises à Fileter par  
interpolation circ.**

de Diamètre de coupe 27,7 mm

**Fresa Integrale per  
interpolazione circolare**

da Diametro 27,7 mm

# Vue d'ensemble

Vista d'insieme



Profil partiel, métrique type 328, 628

Profilo parziale, metrico tipo 328, 628

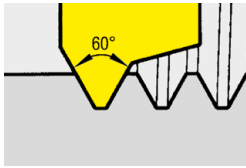

Pas / Passo P	1,0	1,25	1,5	1,75	2,0	2,5
---------------	-----	------	-----	------	-----	-----

Nom.-Ø / Ø nomin.

Type / tipo **328** / Ds 27,7

328.0720.01	≥ 32	≥ 32	≥ 32	≥ 32	≥ 32	
328.1525.01			≥ 34	≥ 34	≥ 34	≥ 34

Typ / type **628** / Ds 27,7

628.1525.01			≥ 34	≥ 34	≥ 34	≥ 34
-------------	--	--	------	------	------	------

Pas / Passo P	3,0	3,5	4,0	4,5	5,0	5,5	6,0
---------------	-----	-----	-----	-----	-----	-----	-----

Nom.-Ø / Ø nomin.

Type / tipo **328** / Ds 27,7

328.3050.01	≥ 40	≥ 38	≥ 38	≥ 38	≥ 38		
328.5060.01					≥ 48	≥ 46	≥ 44

Type / tipo **628** / Ds 27,7

628.3050.01	≥ 40	≥ 38	≥ 38	≥ 38	≥ 38		
628.5060.01					≥ 48	≥ 46	≥ 44

Profil plein, Whitworth type 328, 628

Profilo completo, Whitworth tipo 328, 628

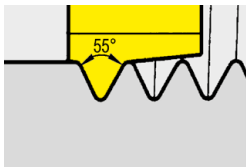

fil./pouce fil./pollici	11
----------------------------	----

Filetage / Filettatura

Type / tipo **328** / Ds 27,7

328.5511.02	G1½"
-------------	------

Type / tipo **628** / Ds 27,7

628.5511.02	G1½"
-------------	------

G

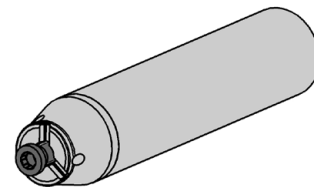
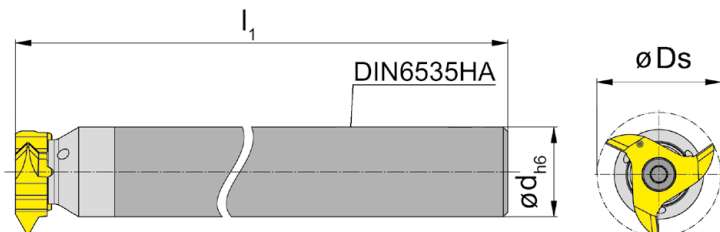
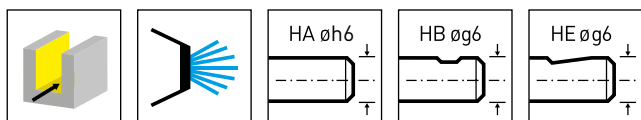

Illustration de coupe à droite représentée

Figura = taglio destro

N° de commande Codice prodotto	d	l <sub>1</sub>	Forme Forma	HWS
M328.0020.10A	20	250	A	328143R
M328.0020.D.05A	20	145	A	328143R
M328.0020.D.06A	20	160	A	328143R
M328.0020.D.07A	20	180	A	328143R
M328.0020.D.05B	20	145	B	328143R
M328.0020.D.06B	20	160	B	328143R
M328.0020.D.07B	20	180	B	328143R
M328.0020.D.05E	20	145	E	328143R
M328.0020.D.06E	20	160	E	328143R
M328.0020.D.07E	20	180	E	328143R

Ds voir plaquettes  
Ds vd. inserti



**Pièces Détachées**

Ricambi

Corps de fraise Corpo fresa	Vis de serrage Vite di serraggio	Tournevis TORX PLUS® Cacciavite TORX PLUS®
M328.0020.10A	5.14T20P	T20PQ
M328.0020.D....	5.17T20P	T20PQ

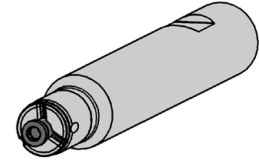
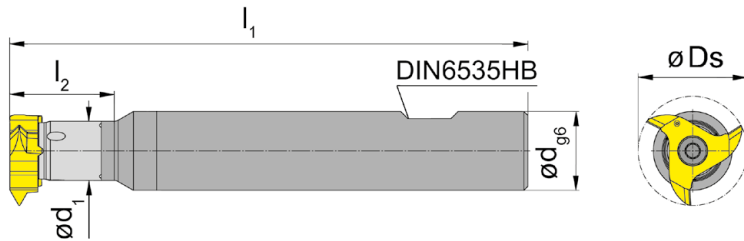
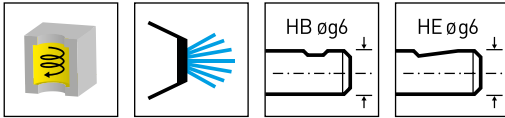

Illustration de coupe à droite représentée  
Figura = taglio destro

N° de commande Codice prodotto	d	l <sub>1</sub>	l <sub>2</sub>	d <sub>1</sub>	Forme Forma	HWS
SM328.0020.05B	20	130	25	15	B	328143R
SM328.0020.06B	20	145	-	20	B	328143R
SM328.0020.07B	20	160	25	15	B	328143R
SM328.0020.08B	20	200	-	20	B	328143R
SM328.0020.05E	20	130	25	15	E	328143R
SM328.0020.06E	20	145	-	20	E	328143R
SM328.0020.07E	20	160	25	15	E	328143R
SM328.0020.08E	20	200	-	20	E	328143R

Matière du corps : alliage de tungstène (donne une bonne résistance aux vibrations)  
Gambo in lega di tungsteno per conferire una buona resistenza alle vibrazioni

Ds voir plaquettes  
Ds vd. inserti

### Pièces Détachées

Ricambi

Corps de fraise Corpo fresa	Vis de serrage Vite di serraggio	Tournevis TORX PLUS® Cacciavite TORX PLUS®
SM328...	5.17T20P	T20PQ

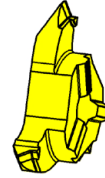
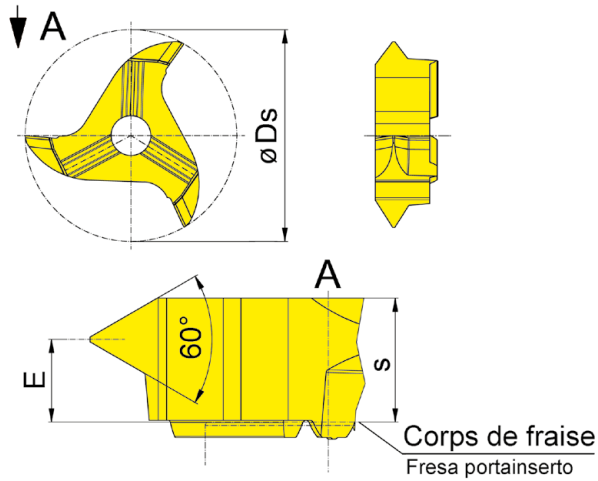
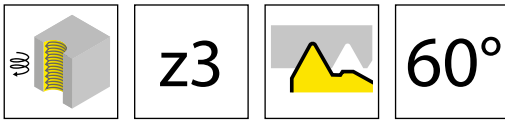

Illustration de coupe à droite représentée  
Figura = taglio destro

▲ en stock  
a stock

△ 4 semaines  
4 settimane

Nuance  
Leghe

N° de commande Codice prodotto	P	P <sub>max</sub>	E	s	Ds	HIS	AS45	TI25	TN35
328.0720.01	1	2	4,6	5,95	27,7	328114R	▲		▲
328.1525.01	1,5	2,5	4,3	5,95	27,7	328114R	▲		▲
328.3050.01	3	5	4,8	7,2	27,7	328114R	▲	▲	▲
328.5060.01	5	6	4,4	7,2	27,7	328114R	▲		▲
	P	●	●	●					
	M	●	●	●					
	K	●	●	●					
	N	○	●	●					
	S	●	●	●					
	H	-	-	-					



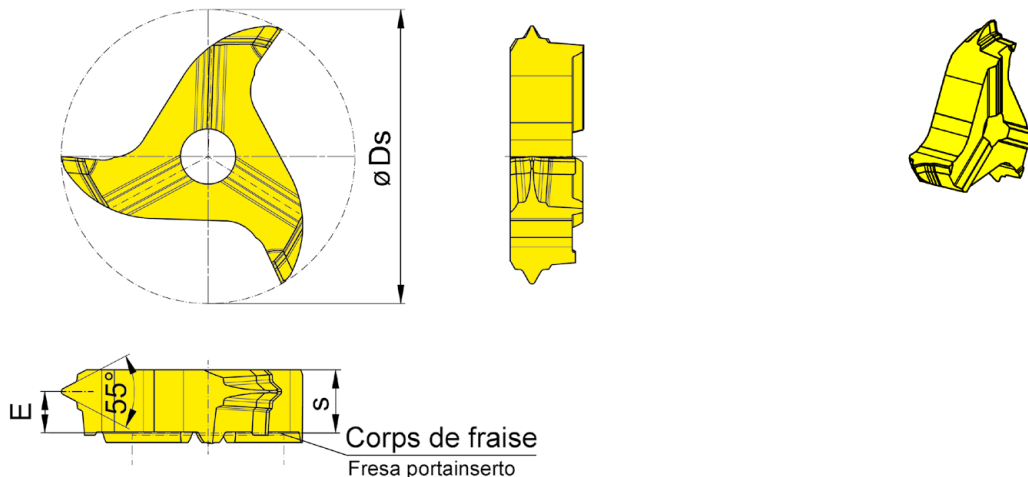
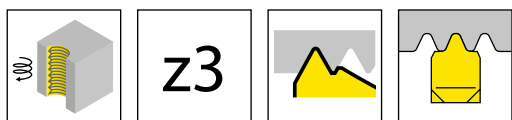

Nuance  
Leghe

Illustration de coupe à droite représentée  
Figura = taglio destro

▲ en stock  
a stock

Δ 4 semaines  
4 settimane

N° de commande Codice prodotto	TPI	E	s	Ds	HIS	AS45
328.5511.02	11	3,9	5,95	27,7	328114R	▲
						P ●
						M ●
						K ●
						N ○
						S ●
						H -

G

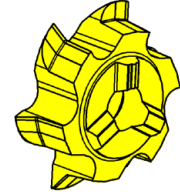
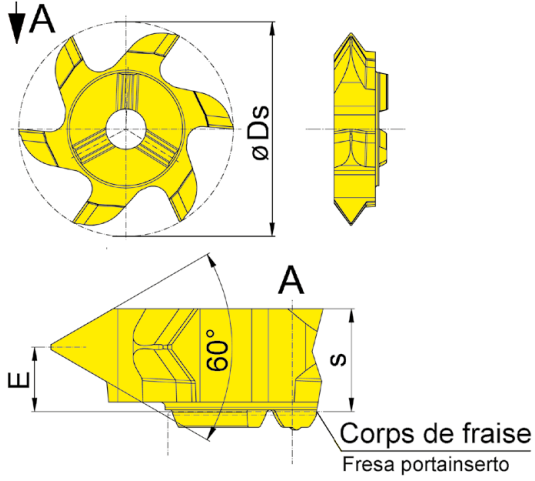
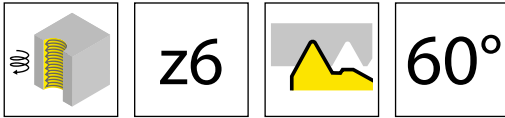

Illustration de coupe à droite représentée  
Figura = taglio destro

▲ en stock  
a stock

▲ 4 semaines  
4 settimane

Nuance  
Leghe

N° de commande Codice prodotto	P	P <sub>max</sub>	E	s	D <sub>s</sub>	HIS	Nuance Leghe	
							AS45	TI25
628.1525.01	1,5	2,5	4,8	6	27,7	328114R	▲	▲
628.3050.01	3	5	3,7	5,75	27,7	328114R	▲	▲
628.5060.01	5	6	3,2	5,75	27,7	328114R	▲	▲
							P	●
							M	●
							K	●
							N	○
							S	●
							H	-



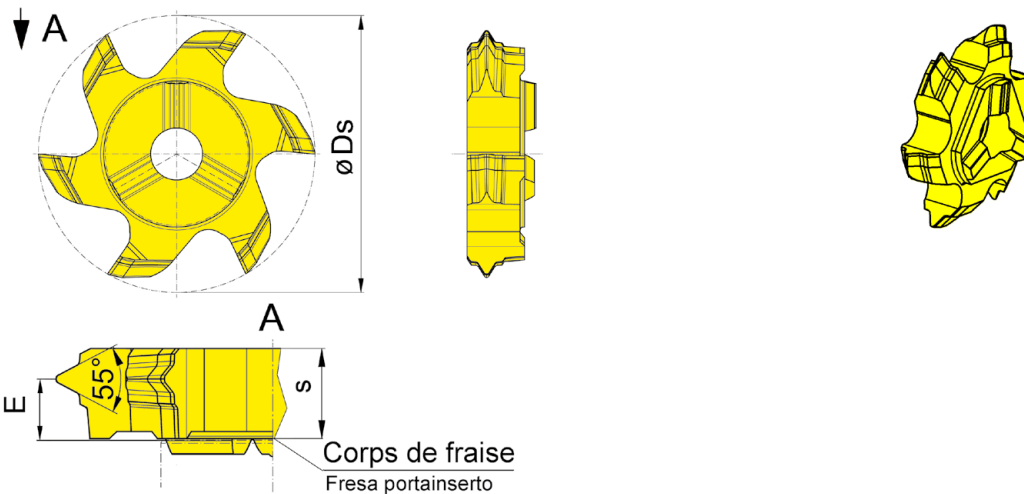
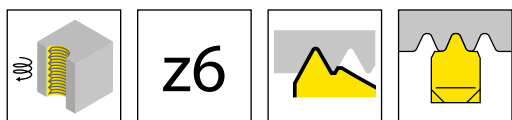

Illustration de coupe à droite représentée  
Figura = taglio destro

▲ en stock  
a stock

Nuance  
Leghe  
Δ 4 semaines  
4 settimane

N° de commande Codice prodotto	TPI	E	s	Ds	HIS	AS45
628.5511.02	11	3,9	5,85	27,7	328114R	▲
						P ●
						M ●
						K ●
						N ○
						S ●
						H -



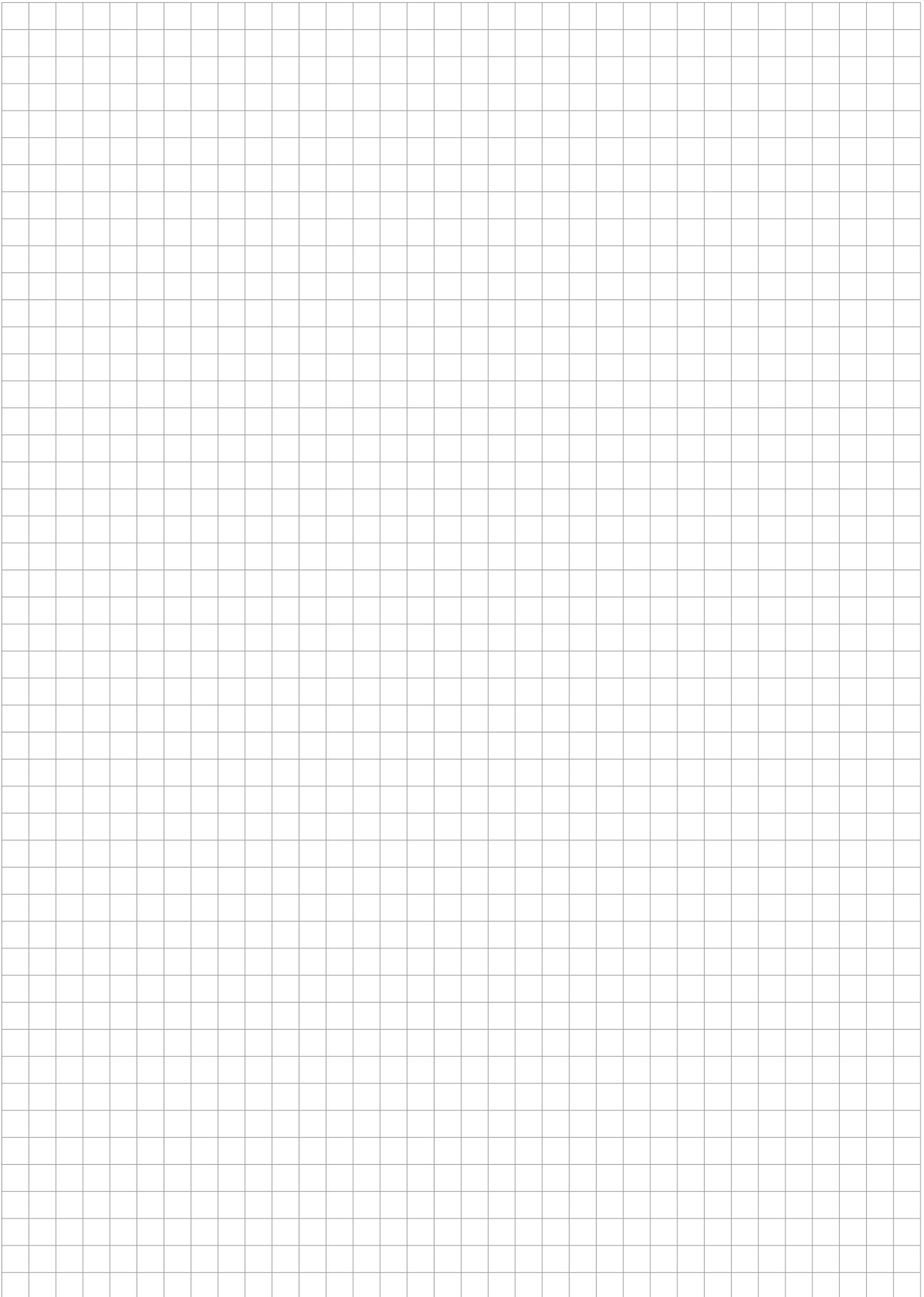

Vue d'ensemble  
Vista d'insieme

Page/Pag.  
338

Corps de fraise  
Corpo fresa  
M332

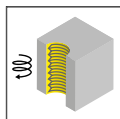

Page/Pag.  
339

Plaquette  
Inserto  
632

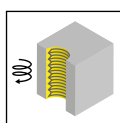

Page/Pag.  
340

G

### Attention:

Le diamètre nominal est toujours le plus grand  $\emptyset$  du filetage.  
En règle générale, la désignation dépend de la taille du filetage.  
Exemple : M12 x 1 -> diamètre nominal 12

Il peut y avoir un phénomène de recoupe, si le diamètre d'alésage est plus petit que celui recommandé.

### Attenzione:

Il diametro nominale è sempre il  $\emptyset$  maggiore della filettatura. Di norma, la designazione si basa sulle dimensioni del filetto.  
Esempio: M12 x 1 -> diametro nominale 12

L'effetto recutting dell'utensile in fresatura può creare degli errori sul profilo se il diametro minimo del componente è minore di quello consigliato.