

M306



G

**Fraises à Fileter par
interpolation circ.**

de Diamètre de coupe 9,6 mm

**Fresa Integrale per
interpolazione circolare**

da Diametro 9,6 mm

Profil partiel, métrique type 108, 306, 606

Profilo parziale, metrico tipo 108, 306, 606

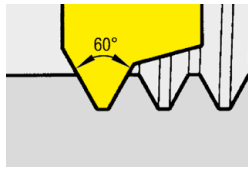

Pas / Passo P	0,5	0,75	1,0	1,25	1,5	1,75	2,0	2,5	3,0
Nom.-Ø / Ø nomin.									
Type / tipo 108 / Ds 9,6									
R/L 108.0205.01	≥ 12	≥ 12							
R/L108.0510.01			≥ 14	≥ 14					
R/L108.0815.01					≥ 16	≥ 16			
Type / tipo 306 / Ds 10,0									
306.0515.01	≥ 12	≥ 12	≥ 13	≥ 13	≥ 14				
306.1020.01							≥ 16		
Type / tipo 306 / Ds 11,7									
306.0815.01					≥ 18				
306.0720.01			≥ 16	≥ 16	≥ 16	≥ 16	≥ 16		
306.2530.01								≥ 20	≥ 20
Type / tipo 606 / Ds 10,0									
606.0515.01	≥ 12	≥ 12	≥ 13	≥ 13	≥ 14				
Type / tipo 606 / Ds 11,7									
606.0720.01			≥ 16	≥ 16	≥ 16	≥ 16	≥ 16		

Profil plein, métrique type 306, 606

Profilo completo, metrico tipo 306

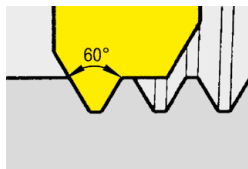

Pas / Passo P	1,5	2,0
Nom.-Ø / Ø nomin.		
Type / tipo 306 / Ds 11,7		
306.0815.02	≥ 22	
Type / tipo 306 / Ds 10,0		
306.1020.02		≥ 24

Pas / Passo P	1,5
Nom.-Ø / Ø nomin.	
Type / tipo 606 / Ds 11,7	
606.0815.02	≥ 22

Profil plein, Whitworth type 306, 606

Profilo completo, Whitworth tipo 306, 606

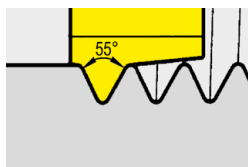

fil./pouce fil./pollici	19	14	11
Filetage / Filettatura			
Type / tipo 306 / Ds 9,7			
306.5519.10.02	G $\frac{1}{4}$ "		
Type / tipo 306 / Ds 11,7			
306.5519.02	G $\frac{3}{8}$ "		
306.5514.02		G $\frac{1}{2}$ "	
306.5511.02			G1"
Type / tipo 606 / Ds 9,7			
606.5519.10.02	G $\frac{1}{4}$ "		
Type / tipo 606 / Ds 11,7			
606.5519.02	G $\frac{3}{8}$ "		
606.5514.02		G $\frac{1}{2}$ "	

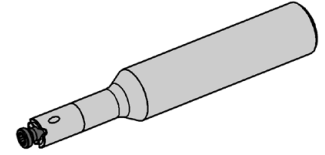
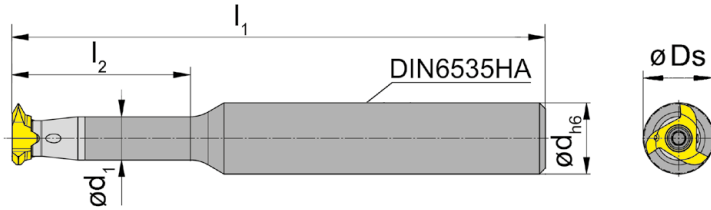
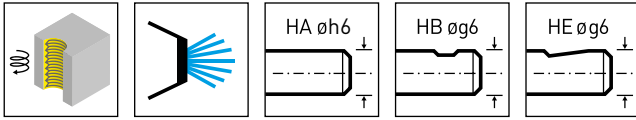

Illustration de coupe à droite représentée
Figura = taglio destro

N° de commande Codice prodotto	d	l ₁	l ₂	d ₁	Forme Forma	HWS
M306.0712.02A	12	90	30	7,3	A	306060R • 306060L
M306.0716.01A	16	100	25	7,3	A	306060R • 306060L
M306.0716.02A	16	110	35	7,3	A	306060R • 306060L
M306.0712.02B	12	90	30	7,3	B	306060R • 306060L
M306.0716.01B	16	100	25	7,3	B	306060R • 306060L
M306.0716.02B	16	110	35	7,3	B	306060R
M306.0712.02E	12	90	30	7,3	E	306060R • 306060L
M306.0716.01E	16	100	25	7,3	E	306060R • 306060L
M306.0716.02E	16	110	35	7,3	E	306060R

Ds voir plaquettes
Ds vd. inserti

Pièces Détachées

Ricambi

Porte outils Portainsero	Vis de serrage Vite di serraggio	Tournevis TORX PLUS® Cacciavite TORX PLUS®
M306...	2.6.5T8EP	T8PL



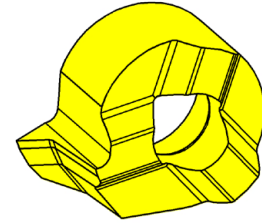
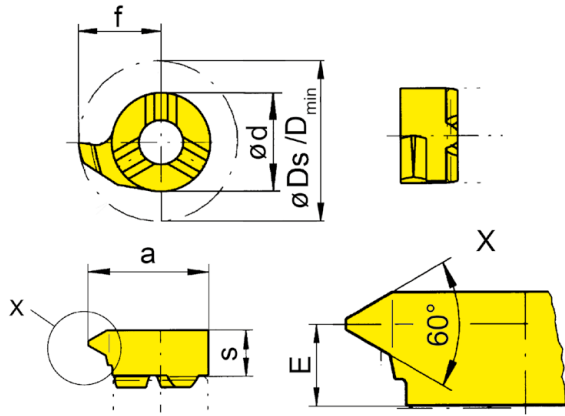

R = version à droite représentée
R = versione destra come in figura

L = version à gauche
L = versione sinistra a specchio

Nuance
Leghe
▲ en stock
a stock
Δ 4 semaines
4 settimane

N° de commande Codice prodotto	P	P _{max}	E	f	a	d	s	D _{min}	D _s	HIS	Nuance Leghe				
											MG12	EG55	TH35	TI25	TN35
R108.0205.01	0,5	0,75	2,8	4,8	7,8	6	3,6	8	9,6	306060R	▲	▲	▲	▲	▲
R108.0815.01	1,5	1,75	2,6	4,8	7,8	6	3,6	8	9,6	306060R	▲	▲	▲	▲	▲
R108.0510.01	1	1,25	2,8	4,8	7,8	6	3,6	8	9,6	306060R	▲	▲	▲	▲	▲
L108.0205.01	0,5	0,75	2,8	4,8	7,8	6	3,6	8	9,6	306060L	Δ	▲	▲	▲	▲
L108.0815.01	1,5	1,75	2,6	4,8	7,8	6	3,6	8	9,6	306060L	Δ	▲	▲	▲	▲
L108.0510.01	1	1,25	2,8	4,8	7,8	6	3,6	8	9,6	306060L	Δ	▲	▲	▲	▲
											P	o	•	•	•
											M	-	o	•	•
											K	-	o	•	•
											N	-	-	•	•
											S	-	-	•	•
											H	-	-	-	-

G

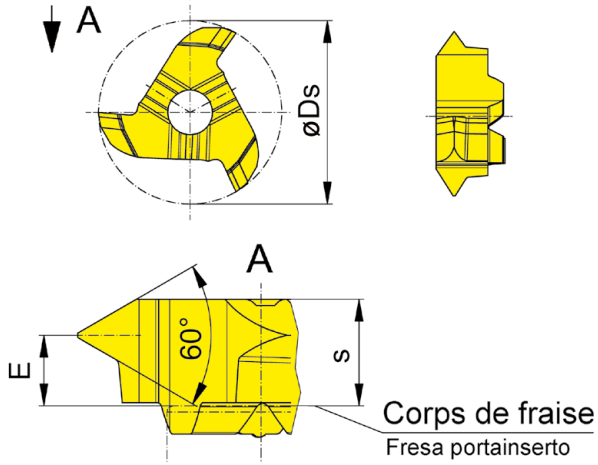
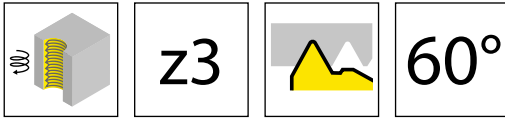

Illustration de coupe à droite représentée
Figura = taglio destro

▲ en stock
a stock

Δ 4 semaines
4 settimane

Nuance
Leghe

N° de commande Codice prodotto	P	P _{max}	E	s	Ds	HIS	Nuance Leghe					
							AS45	TA45	TF45	TI25	TN35	
306.0515.01	0,5	1,5	2,3	3,4	10	306060R	▲	▲			Δ	
306.0720.01	1	2	1,95	3,4	11,7	306060R	▲		▲	▲	▲	
306.0815.01	1,5	1,5	2,25	3,4	11,7	306060R	▲		Δ	▲	▲	
306.1020.01	2	2	2,2	3,4	10	306060R	▲			▲		
306.2530.01	2,5	3	1,7	3,4	11,7	306060R	▲		▲	▲	▲	
							P	●	●	●	●	●
							M	●	●	●	●	●
							K	●	●	●	●	●
							N	○	●	●	●	●
							S	●	●	●	●	●
							H	-	-	-	-	-



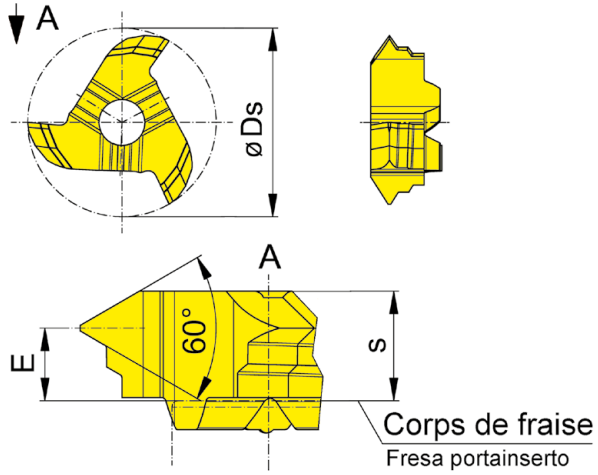
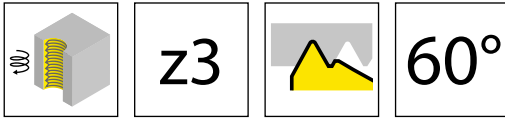

Illustration de coupe à droite représentée
Figura = taglio destro

▲ en stock
a stock

▲ 4 semaines
4 settimane

Nuance
Leghe

N° de commande Codice prodotto	P	E	s	Ds	HIS	Nuance Leghe	
						AS45	TA45
306.0510.02	1	2,5	3,4	11,7	306060R	▲	
306.0815.02	1,5	2,25	3,4	11,7	306060R	▲	▲
306.1020.02	2	2,2	3,4	10	306060R	▲	▲
						P	● ●
						M	● ●
						K	● ●
						N	○ ●
						S	● ●
						H	- -

G

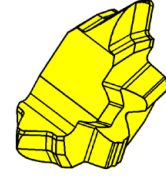
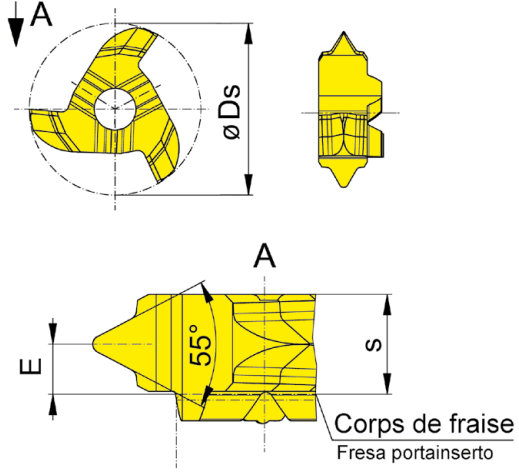
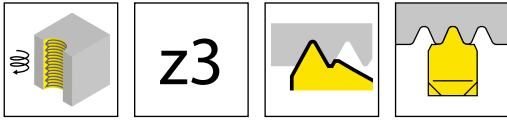

Illustration de coupe à droite représentée
Figura = taglio destro

▲ en stock a stock
Δ 4 semaines 4 settimane
Nuance Leghe

N° de commande Codice prodotto	TPI	E	s	Ds	HIS	Nuance Leghe				
						AS45	TA45	TF45	TI25	TN35
306.5511.02	11	1,7	3,4	11,7	306060R	▲	▲		Δ	
306.5514.02	14	2	3,4	11,7	306060R	▲	▲			Δ
306.5519.02	19	2,2	3,4	11,7	306060R	▲	▲			
306.5519.10.02	19	2,2	3,4	9,7	306060R	▲	▲			
P						●	●	●	●	●
M						●	●	●	●	●
K						●	●	●	●	●
N						○	●	●	●	●
S						●	●	●	●	●
H						-	-	-	-	-



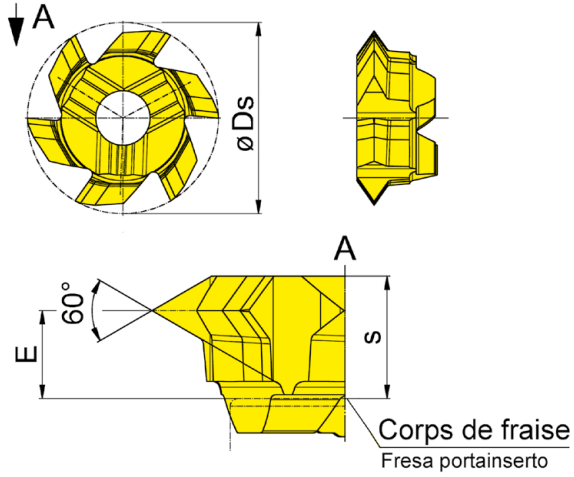
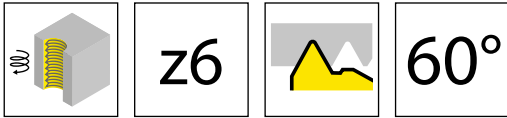

Illustration de coupe à droite représentée
Figura = taglio destro

Nuance
Leghe
▲ en stock
a stock
Δ 4 semaines
4 settimane

N° de commande Codice prodotto	P	P _{max}	E	s	Ds	HIS	Nuance Leghe	
							AS45	TA45
606.0515.01	0,5	1,5	2,3	3,15	10	306060R	▲	▲
606.0720.01	1	2	1,95	3,15	11,7	306060R	▲	▲
							P	●
							M	●
							K	●
							N	○
							S	●
							H	-

G

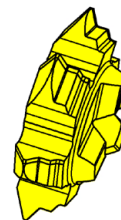
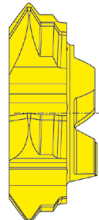
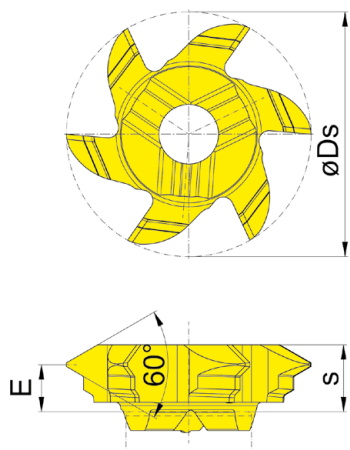
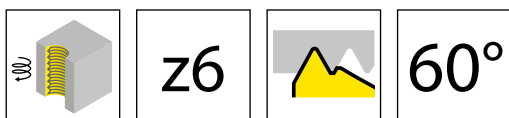

Illustration de coupe à droite représentée
Figura = taglio destro

▲ en stock
a stock

Nuance
Leghe
Δ 4 semaines
4 settimane

N° de commande Codice prodotto	P	E	s	Ds	HIS	AS45	TA45
606.0510.02	1	2,5	3,2	11,7	306060R	▲	▲
606.0815.02	1,5	2,25	3,2	11,7	306060R	▲	▲
	P	●	●				
	M	●	●				
	K	●	●				
	N	○	●				
	S	●	●				
	H	-	-				



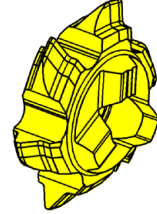
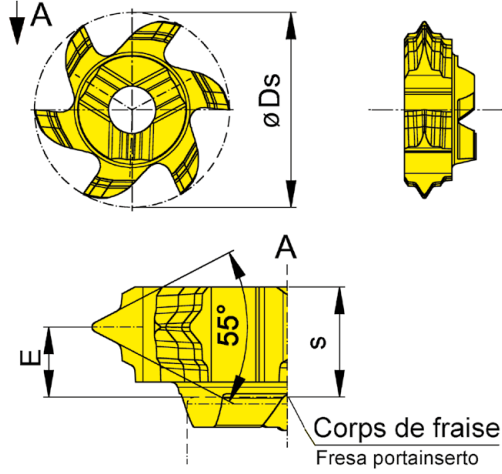
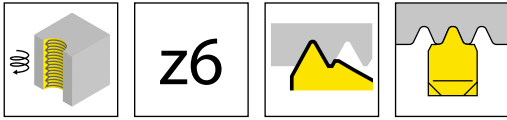

Illustration de coupe à droite représentée
Figura = taglio destro

▲ en stock
a stock

△ 4 semaines
4 settimane

Nuance
Leghe

N° de commande Codice prodotto	TPI	E	s	Ds	HIS	Nuance Leghe		
						AS45	TA45	TI25
606.5519.10.02	19	2,1	3,3	9,7	306060R	▲	▲	△
606.5514.02	14	2	3,3	11,7	306060R	▲	▲	△
606.5519.02	19	2,1	3,3	11,7	306060R	▲	▲	△
						P	●	●
						M	●	●
						K	●	●
						N	○	●
						S	●	●
						H	-	-

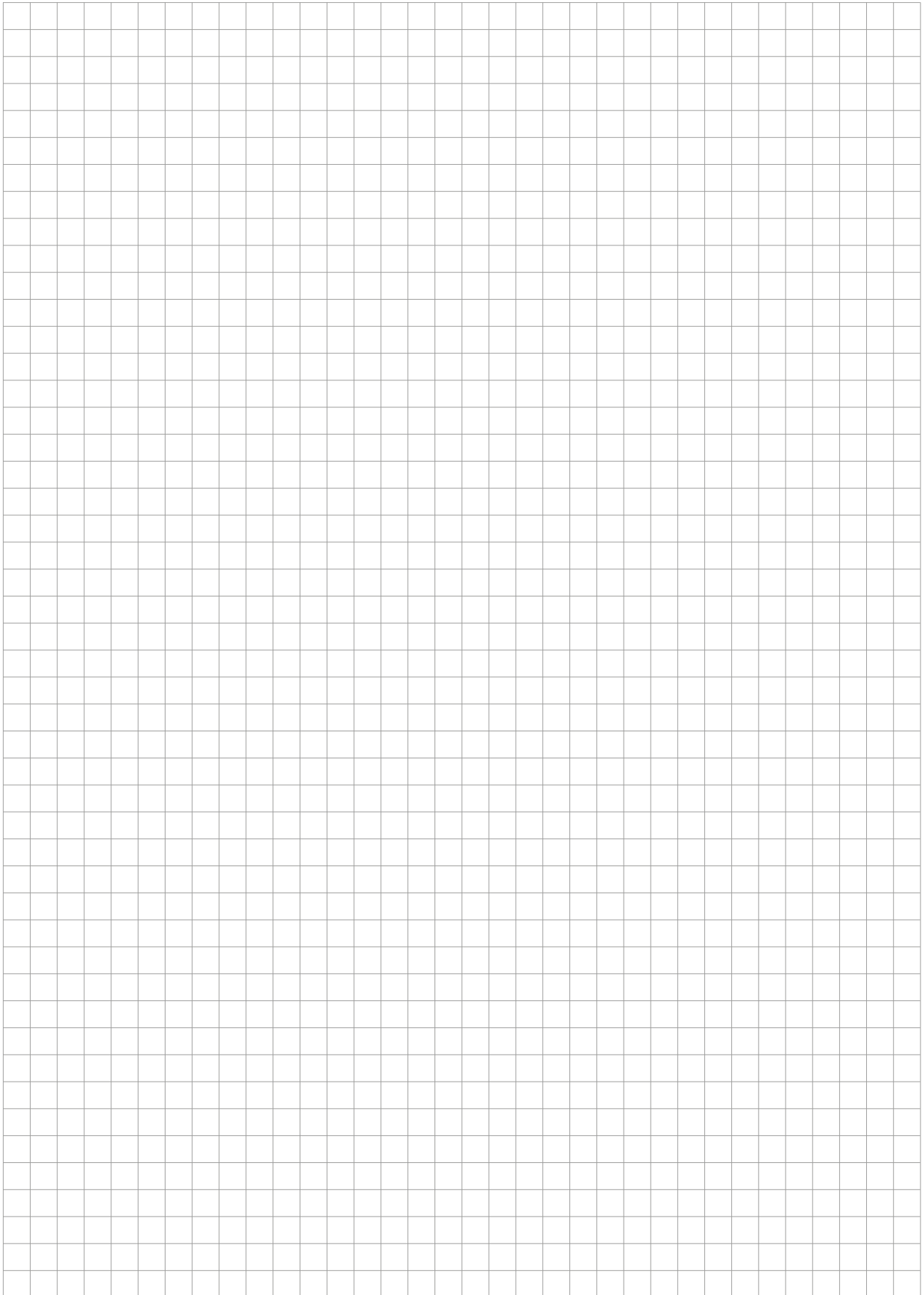

Vue d'ensemble
Vista d'insieme

Page/Pag.
298

Corps de fraise
Corpo fresa
M308

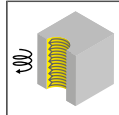

Page/Pag.
299

Plaquette
Inserto
111/308/608

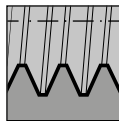

Page/Pag.
300-301

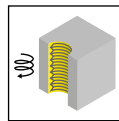

Page/Pag.
302-305

G

Attention:

Le diamètre nominal est toujours le plus grand \emptyset du filetage.
En règle générale, la désignation dépend de la taille du filetage.
Exemple : M12 x 1 -> diamètre nominal 12

Il peut y avoir un phénomène de recoupe, si le diamètre d'alésage est plus petit que celui recommandé.

Attenzione:

Il diametro nominale è sempre il \emptyset maggiore della filettatura. Di norma, la designazione si basa sulle dimensioni del filetto.
Esempio: M12 x 1 -> diametro nominale 12

L'effetto recutting dell'utensile in fresatura può creare degli errori sul profilo se il diametro minimo del componente è minore di quello consigliato.