

Accessories for Drill Chucks

Service Keys | Gaskets | Assembly Tool

Service Keys for Drill Chucks

Service Key		Tightening Torque Nm	Part No.
Service Key	Type		
2.50	B	15	415577
6.00	B	15	115578

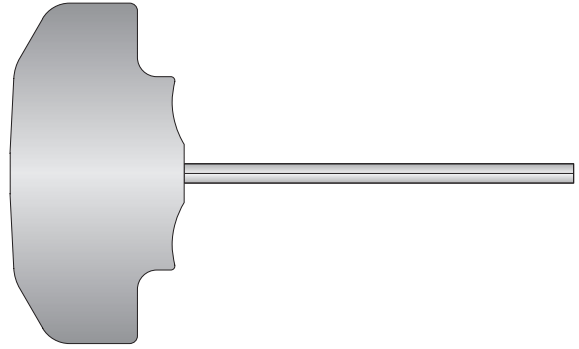

Gaskets for Drill Chucks

	Gasket		Part No.
	Gasket Diameter	Clamping Diameter	
	3.00 - 6.00	0.50 - 13.00	387113
	6.00 - 13.00	0.50 - 13.00	387114
m	3.00 - 6.00	2.50 - 16.00	387115
	6.00 - 16.00	2.50 - 16.00	387116

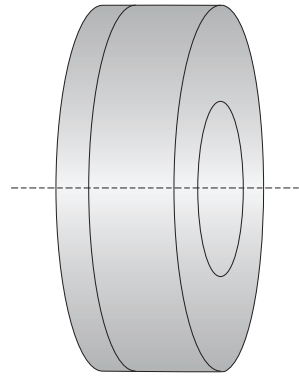

Assembly Tool for Gasket

Part No.
387112

