

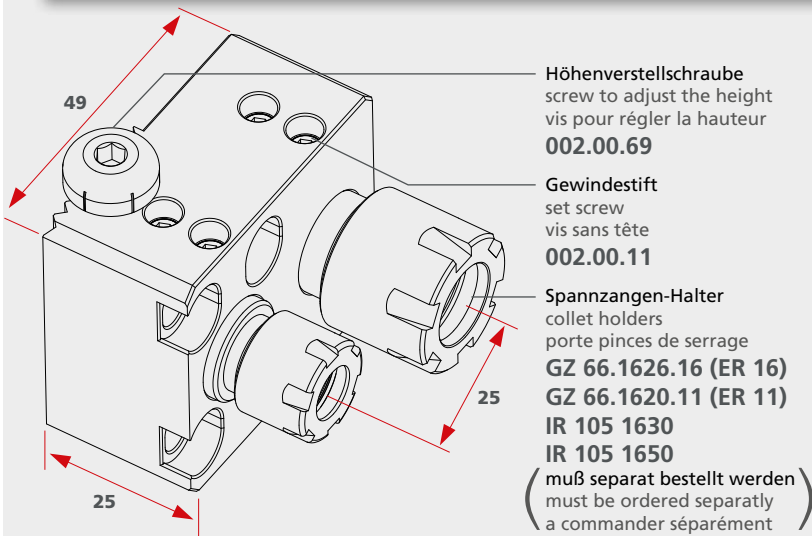

N10
Art. Nr. 12-0037

Anwendungsbereich **Rückseitenbearbeitung**
 Application **back working**

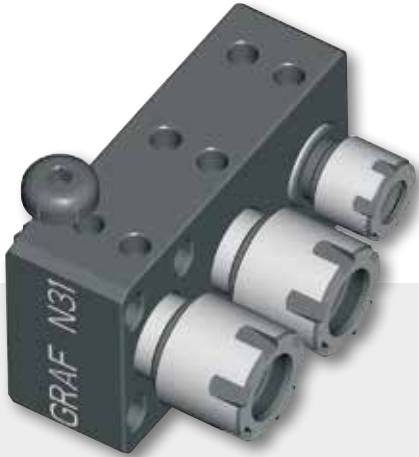



N31

Art. Nr. 12-0798

Anwendungsbereich **Rückseitenbearbeitung**
Application **back working**

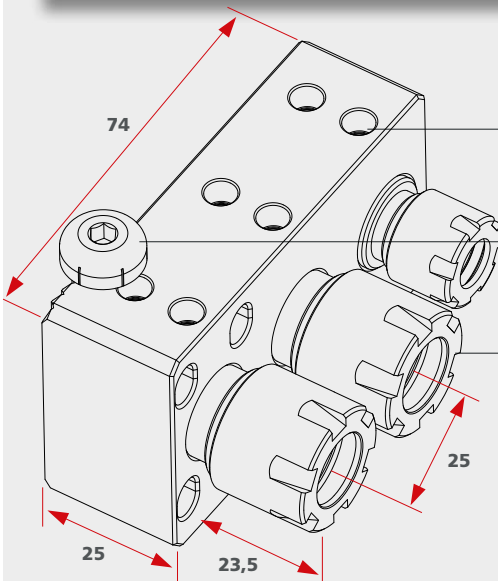

Gewindestift
set screw
vis sans tête
001.01.24

Höhenverstellungsschraube
screw to adjust the height
vis pour régler la hauteur
002.00.69

Spannzangen-Halter
collet holders
porte pinces de serrage
GZ 66.1620.11 (ER 11)
GZ 66.1626.16 (ER 16)
oder IR 105.1630
IR 105 1630
IR 105 1650

(muß separat bestellt werden)
(must be ordered separately)
(à commander séparément)

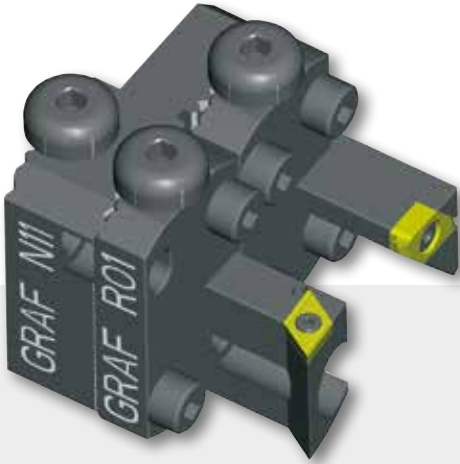

N11

Art. Nr. 12-0038

Anwendungsbereich **Rückseitenbearbeitung**

Application **back working**

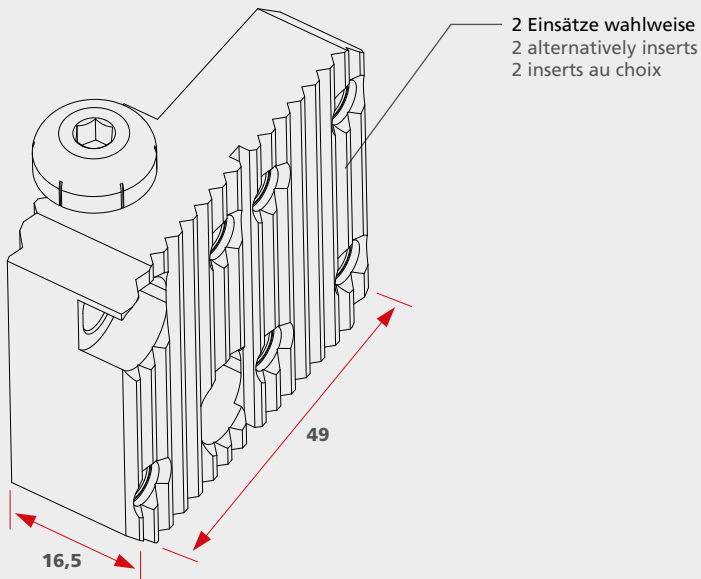

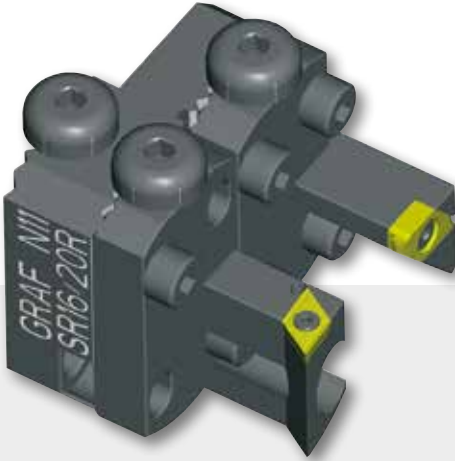

N11SR16/20R
Art. Nr. 12-0053

Anwendungsbereich **Rückseitenbearbeitung**
Application **back working**

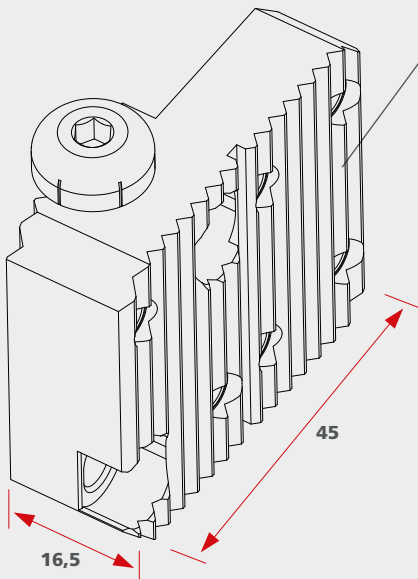

2 Einsätze wahlweise
2 alternatively inserts
2 inserts au choix

Für Grundhalter

For basic holder

Pour porte-outil
de base

G 022 025 SR16/20R
G 022 030 SR32
G 025 060
G 028 006
G 032 25
G 033 40
G 016 011 SR10
G 025 040
G 032 045
G 032 030
G 022 020 SR10
G 022 024-S2
G 023 030
G 028 015
G 025 020

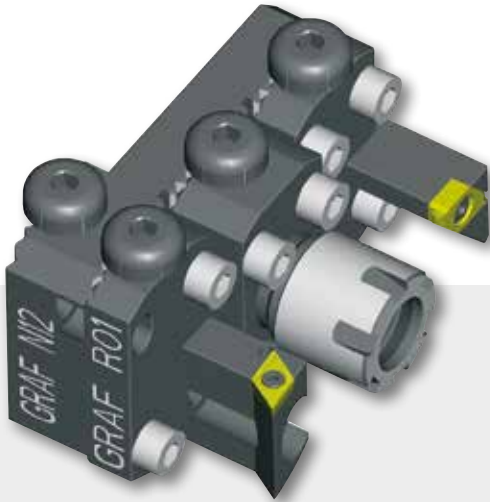

N12

Art. Nr. 12-0509

Anwendungsbereich **Rückseitenbearbeitung**

Application **back working**

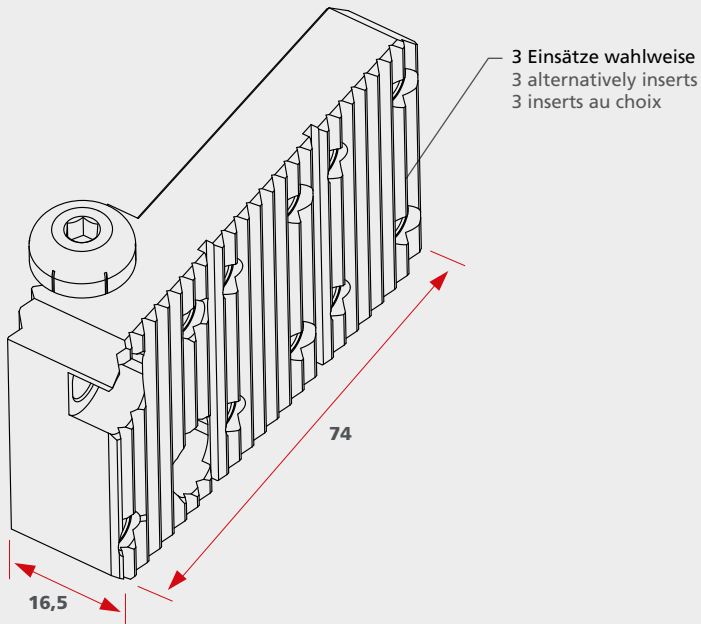



N12 SR16/20 R
Art. Nr. 12-0510

Anwendungsbereich **Rückseitenbearbeitung**
Application **back working**

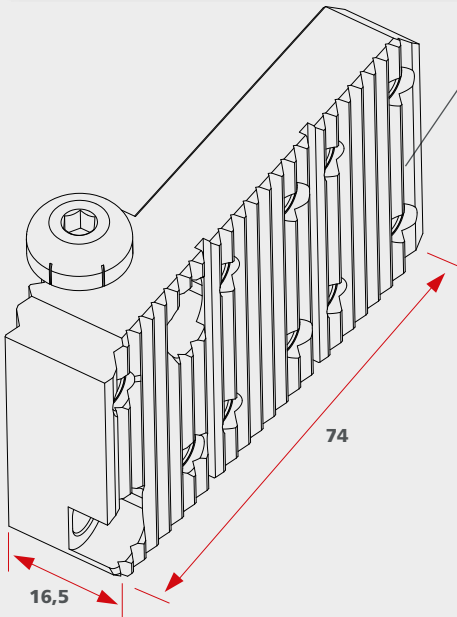

3 Einsätze wahlweise
3 alternatively inserts
3 inserts au choix

Für Grundhalter

For basic holder

Pour porte-outil
de base

G 022 025 SR16/20R
G 022 030 SR32
G 025 060
G 028 006
G 032 25
G 033 40
G 016 011 SR10
G 025 040
G 032 045
G 032 030
G 022 020 SR10
G 022 024-S2
G 023 030
G 028 015
G 025 020

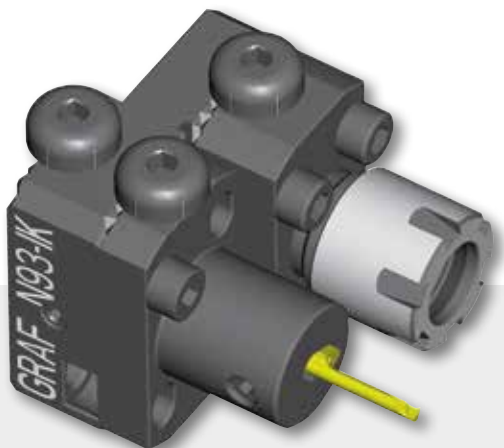

N93IK

Art. Nr. 12-0528

Anwendungsbereich **Rückseitenbearbeitung**

Application **back working**

