

### UPA 3 Boring Head Diagram

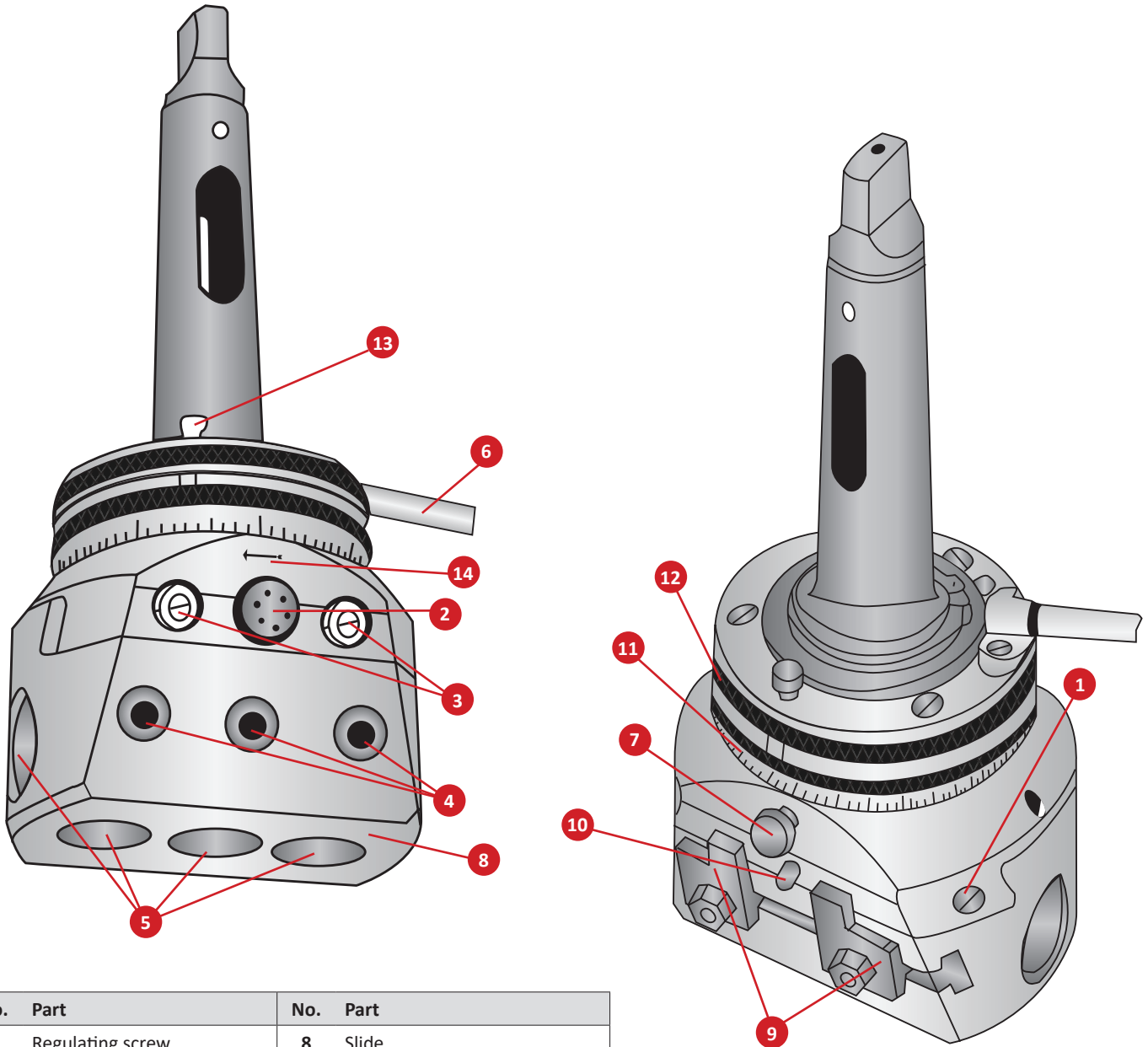

No.	Part	No.	Part
1	Regulating screw	8	Slide
2	Locking screw	9	Stop
3	Setting screws	10	Fixed pin
4	Fastening screw	11	Scale ring
5	Tool post holes	12	Holding ring
6	Holding rod	13	Button for return movement
7	Feed button	14	Arrow

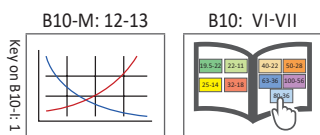

A  
B  
C  
D  
E  
F  
G  
H  
I  
J  
K  
L  
M  
INDEX

### UPA 4 / 5-S 6 Boring Heads Diagram

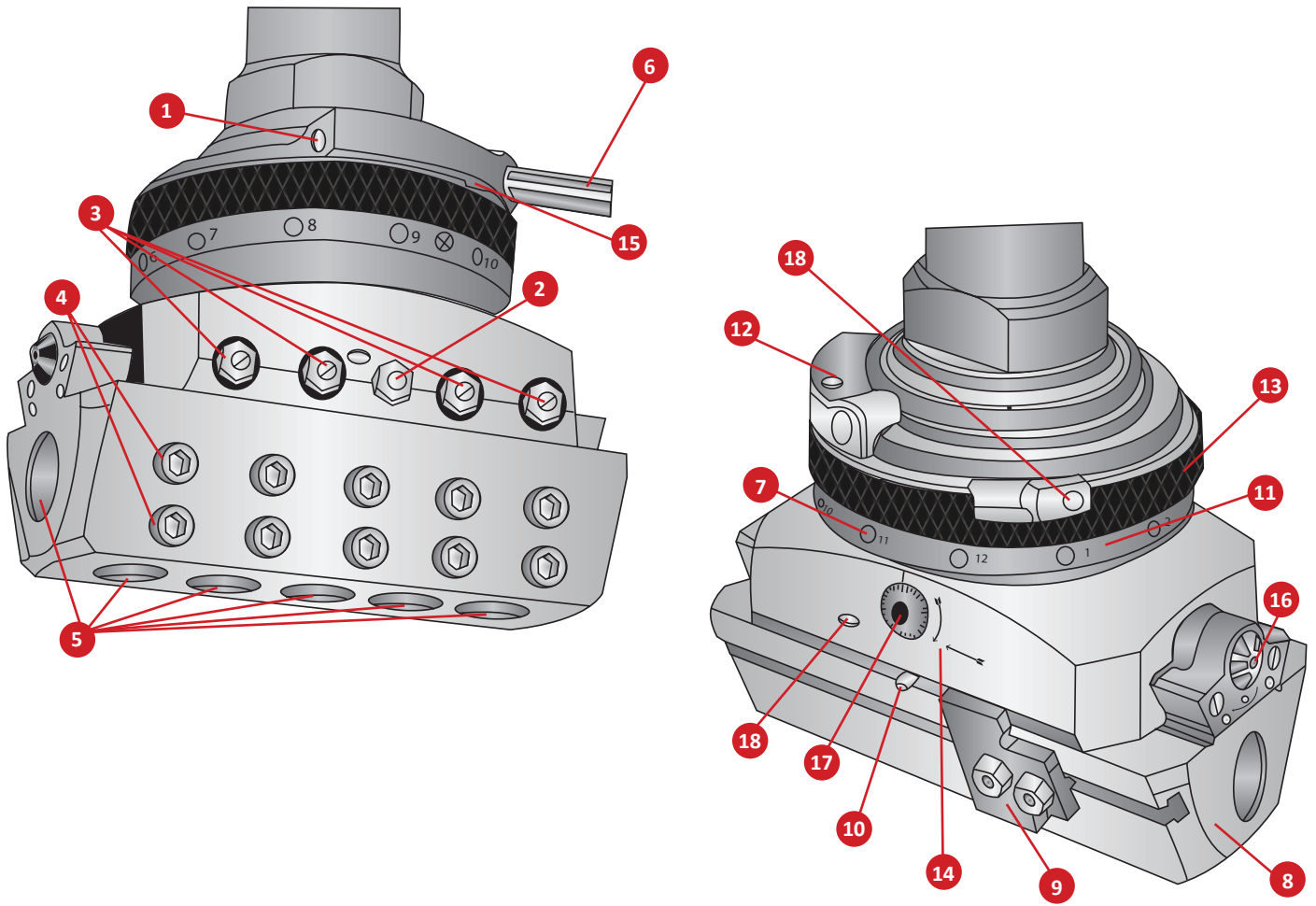

No.	Part	No.	Part
1	Regulating screw	10	Fixed pin
2	Locking screw	11	Scale ring
3	Setting screws	12	Retaining ring
4	Fastening screws	13	Feed ring
5	Tool post holes	14	Arrow
6	Holding rod	15	Recess
7	Feed buttons	16	Quick setting dial
8	Slide with rotation bores	17	Fine setting dial
9	Stop	18	Release ring

