

### CAT Master Shanks with Metric Threads

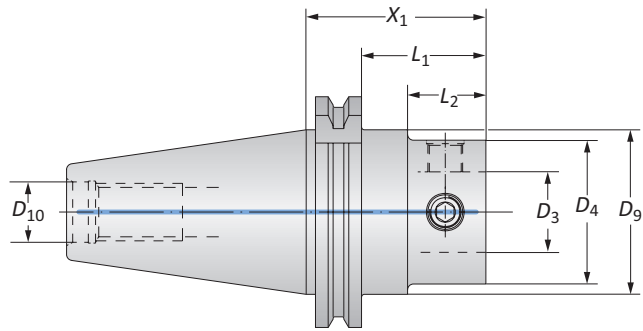

Taper Size	Connection		Shank				Weight	Part No.	
	$D_4$   $D_3$	$X_1$	$L_1$	$L_2$	$D_9$	$D_{10}$			
Ⓜ	40	50 - 28	62.00	42.90	–	44.45	M16 x 2	1.30 (kg)	132022T016960
	40	63 - 36	82.00	62.90	–	44.45	M16 x 2	1.80 (kg)	132066T016960
	50	50 - 28	62.00	42.90	27.00	69.85	M24 x 3	3.40 (kg)	132022T016962
	50	63 - 36	72.00	52.90	37.00	69.85	M24 x 3	3.70 (kg)	132066T016962
	50	80 - 36	72.00	52.90	–	69.85	M24 x 3	4.20 (kg)	132088T016962
	50	100 - 56	105.00	85.90	–	69.85	M24 x 3	5.20 (kg)	132076T016962

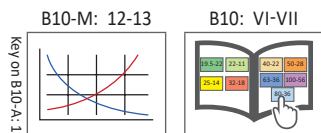

Ⓜ = Metric (mm)

**⚠ WARNING** Exceeding weight capacity for machine tool spindle and tool changer can cause machine damage and/or serious injury. To prevent:  
 -Consult machine tool builder for machine's weight limitations.  
 -Refer to example on page B10-M: 11 for calculating tool assembly weight  
 Factory technical assistance is also available for specific applications through our Application Engineering department. *email: engineering.eu@alliedmachine.com*

**⚠ WARNING** Tool failure can cause serious injury. To prevent:  
 -Do not exceed recommended 10xD length-to-diameter ratio or exceed 4 total components (including shank)  
 -When using Alu-Line® components, do not exceed recommended 5xD length-to-diameter ratio  
 -When using tool steel components, do not exceed recommended 6xD length-to-diameter ratio  
 -When using heavy metal reducers, do not exceed recommended 8xD length-to-diameter ratio  
 -When using a carbide shank, do not exceed recommended 9xD length-to-diameter ratio  
 -When using a NOVITECH® module, do not exceed recommended 10xD length-to-diameter ratio  
 -Refer to examples on pages B10-M: 8-10 for calculating length-to-diameter ratio  
 Factory technical assistance is available for your specific applications through our Application Engineering department. *email: engineering.eu@alliedmachine.com*

A  
B  
C  
D  
E  
F  
G  
H  
I  
J  
K  
L  
M  
INDEX