

Holding Arbors for Milling Cutters

Central Coolant Feed | Shell Mill Adapter Range: 16.00 mm - 40.00 mm

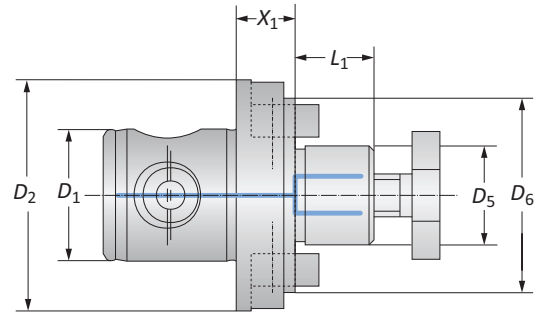
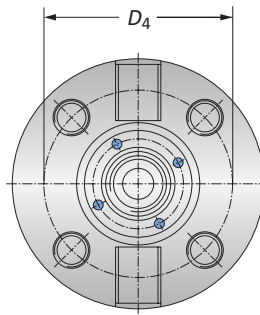

MVS Connection	Adapter Range	Holding Arbor				Weight	Part No.
		D_2 D_1	D_5	X_1	L_1		
50 - 28	16.00	16.00	17.00	–	40.00	0.40 (kg)	162032
50 - 28	22.00	16.00	19.00	–	50.00	0.50 (kg)	162033
m 63 - 36	27.00	16.00	21.00	–	60.00	0.80 (kg)	161082
80 - 36	32.00	16.00	24.00	–	78.00	1.10 (kg)	209080
80 - 36	40.00	19.00	27.00	66.70	89.00	1.50 (kg)	209081

NOTE: See page B10-G: 15 for holding arbor with MVS 100 - 56 connection

