

GRAF Mehrkant-Drückgerät zum Innendrücker
GRAF multi-sided hitting equipment for interior pressing
GRAF appareil pour brochage tournant intérieur

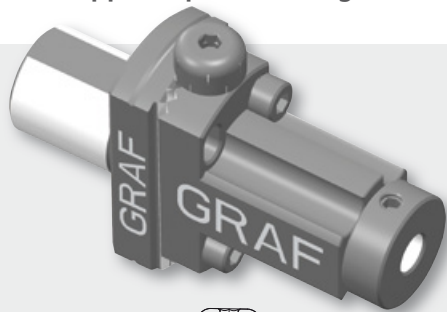

Mehrkant-Stößel zum Innendrücker ASP

Multi-sided rams for interior pressing ASP

Poinçon multipans pour brochage intérieur ASP

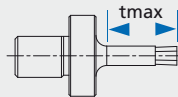

Bestell-Nr.	SW
GM 77.008.02	SK/SW 2
GM 77.008.03	SK/SW 3
GM 77.008.04	SK/SW 4
GM 77.008.05	SK/SW 5
GM 77.008.06	SK/SW 6
GM 77.008.08	SK/SW 8
GM 77.008.10	SK/SW 10

Abmasse und Stosstiefe (tmax = 15) nach Kundenwunsch

Dimensions (tmax = 15) according to customer drawing

Dimensions (tmax = 15) selon dessins fournis par le client

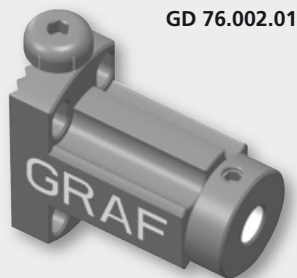
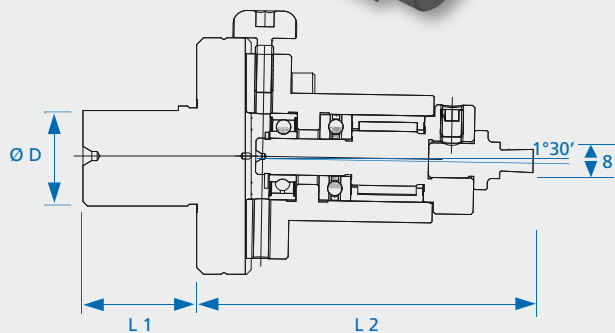

	Bestell-Nr.	Ø D	L 1	L 2
	GD 76.3440.10	3/4"	40	58
	GD 76.3450.10	3/4"	50	58
	GD 76.2030.10	20	30	58
	GD 76.1060.10	1"	60	58
	GD 76.2540.10	25	40	58
	GD 76.2560.10	25	60	58
	GD 76.3225.10	32	25	64
	GD 76.3340.10	33	40	64
	GD 76.3045.10	30	45	69
	GD 76.3444.10	34	44	64
	GD 76.25150.10	25	150	58
	GD 76.1621.10	16	21	58
	GD 76.22120.10	22	120	58
	GD 76.2225.10 - SR16/20R	22	25	64
	GD 76.2230.10 - SR32	22	30	64
	GD 76.2238.10	22	38	58
	GD 76.2250.10	22	50	58
	GD 76.2270.10	22	70	58
	GD 76.20100.10	20	100	58
	GD 76.20145.10	20	145	58
	GD 76.20185.10	20	185	58
	GD 76.2880.10	28	80	64

GRAF Mehrkant-Drückgerät zum Innendrücken
GRAF multi-sided hitting equipment for interior pressing
GRAF appareil pour brochage tournant intérieur

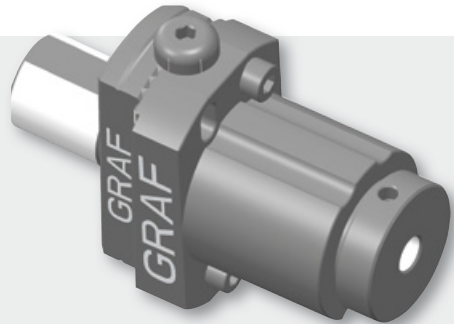

Bestell-Nr.	SW
GM 77.008.02	SK/SW 2
GM 77.008.03	SK/SW 3
GM 77.008.04	SK/SW 4
GM 77.008.05	SK/SW 5
GM 77.008.06	SK/SW 6
GM 77.008.08	SK/SW 8
GM 77.008.10	SK/SW 10

Mehrkant-Stößel zum Innendrücken ASP
Multi-sided rams for interior pressing ASP
Poinçon multipans pour brochage intérieur ASP

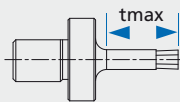

Abmasse und Stosstiefe (tmax = 15) nach Kundenwunsch
Dimensions (tmax = 15) according to customer drawing
Dimensions (tmax = 15) selon dessins fournis par le client

	STAR-Maschinen	Bestell-Nr. GD 78.2225-SR16/20R	D 22	L1 25	L2 72	B 28
	TORNOS-Maschinen	GD 78.2040	20	40	72	28
	HANWA-Maschinen	GD 78.2040	20	40	72	28
		GD 78.2570	25	70	72	28
	TRAUB-Maschinen	GD 78.1640	16	40	72	28
	Kurzdreher Revoler VDI 30	GD 78.VDI30	VDI 30	55	100	46

Bestell-Nr. GD 78.001.00

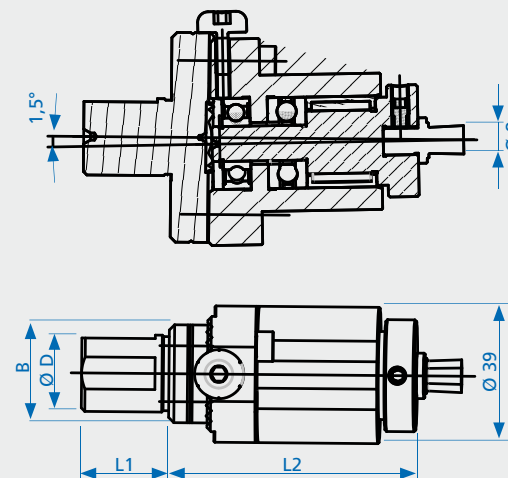
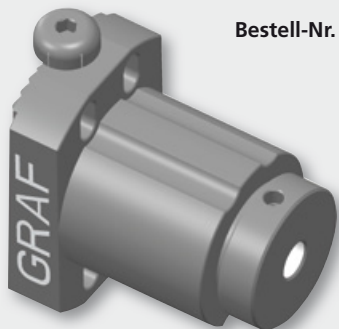

GRAF Mehrkant-Drückgerät zum Aussendrücken
GRAF multi-sided hitting equipment for external (surface) broaching
GRAF appareil pour brochage tournant extérieur

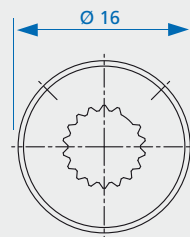
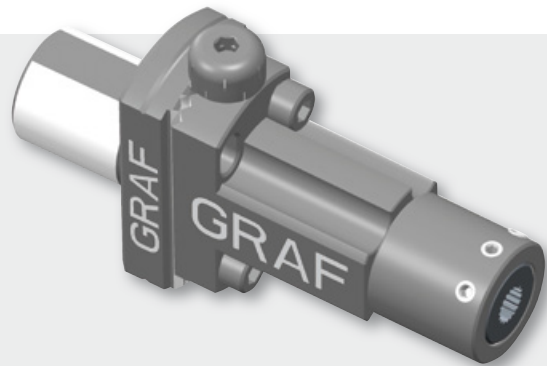

Mehrkant-Büchse zum
Außendrücken
Multi-edged pot broach for
external surface broaching
Bague profilée pour brochage
extérieur

Bestell-Nr. GMA 77.016.A
Abmessungen nach
Kundenzeichnung
Dimensions according to
customer drawing
Dimensions selon dessins
fournis par le client

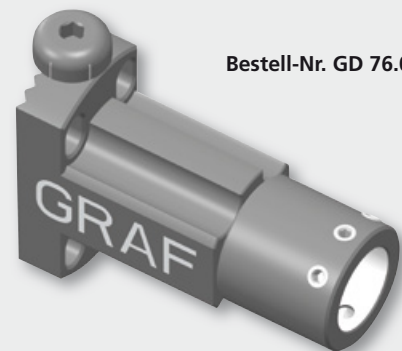
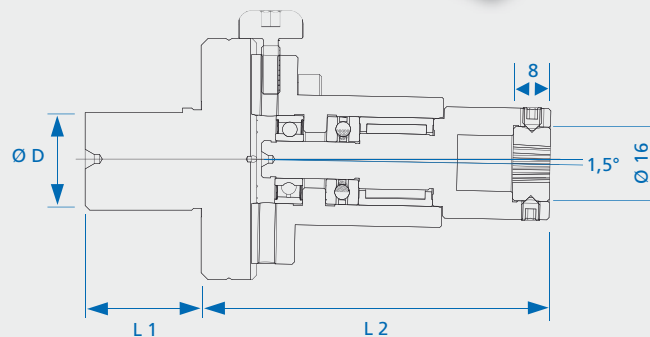

Bestell-Nr. GD 76.002.02

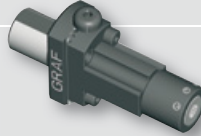
	Bestell-Nr.	Ø D	L 1	L 2
	GDA 76.3440.16	3/4"	40	70
	GDA 76.3450.16	3/4"	50	70
	GDA 76.2030.16	20	30	70
	GDA 76.1060.16	1"	60	70
	GDA 76.2540.16	25	40	70
	GDA 76.2560.16	25	60	76
	GDA 76.3225.16	32	25	76
	GDA 76.3340.16	33	40	76
	GDA 76.3045.16	30	45	82
	GDA 76.3444.16	34	44	76
	GDA 76.25150.16	25	150	70
	GDA 76.1621.16	16	21	70
	GDA 76.22120.16	22	120	70
	GDA 76.2225.16 - SR16/20R	22	25	76
	GDA 76.2230.16 - SR32	22	30	76
	GDA 76.2238.16	22	38	70
	GDA 76.2250.16	22	50	70
	GDA 76.2270.16	22	70	70
	GDA 76.20100.16	20	100	70
	GDA 76.20145.16	20	145	70
	GDA 76.20185.16	20	185	70
	GDA 76.2880.16	28	80	76