

Drill Chucks for Clockwise & Counterclockwise Rotation

Clamping Diameter Range: 0.50 mm - 16.00 mm

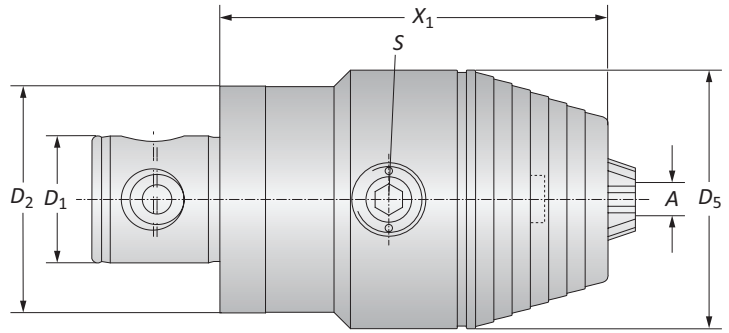

| MVS Connection | Clamping Range | Drill Chuck | | | Weight | Part No. |
|--------------------|----------------|---------------|-------|--------|-----------|----------|
| | | D_2 D_1 | X_1 | D_5 | | |
| m 50 - 28 | 0.50 - 13.00 | 80.00 | 50.00 | s6 / B | 1.10 (kg) | 209088 |
| m 50 - 28 | 2.50 - 16.00 | 85.00 | 57.00 | s6 / B | 1.30 (kg) | 209089 |
| m 63 - 36 | 0.50 - 13.00 | 80.00 | 50.00 | s6 / B | 1.30 (kg) | 209090 |
| m 63 - 36 | 2.50 - 16.00 | 85.00 | 57.00 | s6 / B | 1.50 (kg) | 209091 |

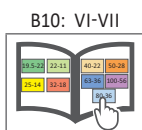
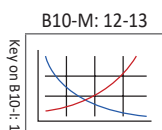

m = Metric (mm)