

Alu-Line Basic D 40 Serrated Slides

Diameter Range: 200.00 mm - 520.00 mm

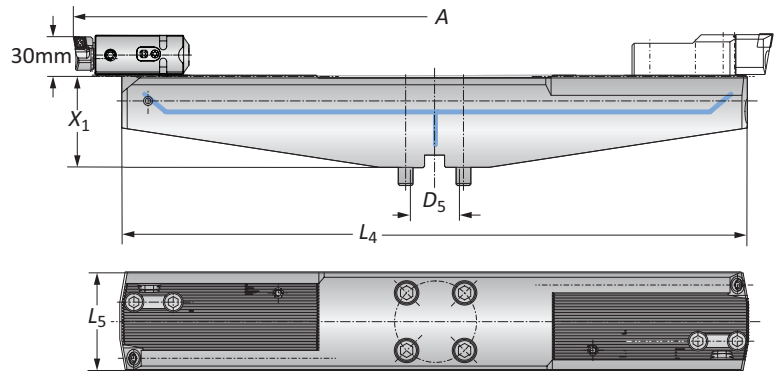

	Connection	Boring Range	Serrated Slide			Weight	Part No.
	D_5	A	X_1	L_4	L_5		
Ⓜ	D 40	200.00 - 280.00	75.00	190.00	80.00	2.80 (kg)	349021
	D 40	280.00 - 360.00	75.00	270.00	80.00	3.80 (kg)	349022
	D 40	360.00 - 440.00	75.00	350.00	80.00	5.00 (kg)	349023
	D 40	440.00 - 520.00	75.00	430.00	80.00	6.00 (kg)	349024

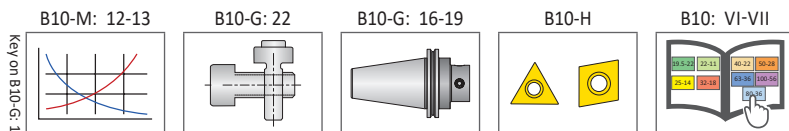

Ⓜ = Metric (mm)

⚠ WARNING Exceeding weight capacity for machine tool spindle and tool changer can cause machine damage and/or serious injury. To prevent:
 -Consult machine tool builder for machine's weight limitations.
 -Refer to example on page B10-M: 11 for calculating tool assembly weight
 Factory technical assistance is also available for specific applications through our Application Engineering department. *email: engineering.eu@alliedmachine.com*

⚠ WARNING Tool failure can cause serious injury. To prevent:
 -Do not exceed recommended 10xD length-to-diameter ratio or exceed 4 total components (including shank)
 -When using Alu-Line® components, do not exceed recommended 5xD length-to-diameter ratio
 -When using tool steel components, do not exceed recommended 6xD length-to-diameter ratio
 -When using heavy metal components, do not exceed recommended 8xD length-to-diameter ratio
 -When using a carbide shank, do not exceed recommended 9xD length-to-diameter ratio
 -When using a NOVITECH module, do not exceed recommended 10xD length-to-diameter ratio
 -Refer to examples on pages B10-M: 8-10 for calculating length-to-diameter ratio
 Factory technical assistance is available for your specific applications through our Application Engineering department. *email: engineering.eu@alliedmachine.com*



Alu-Line Basic D 60 Serrated Slides

Diameter Range: 200.00 mm - 505.00 mm

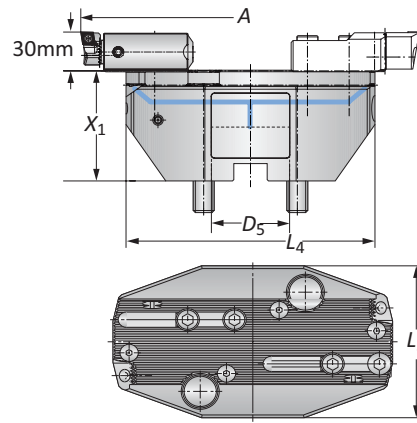

	Connection	Boring Range	Serrated Slide			Weight	Part No.
	D_5	A	X_1	L_4	L_5		
Ⓜ	D 60	200.00 - 280.00	85.00	191.00	110.00	4.10 (kg)	349051
	D 60	275.00 - 355.00	85.00	264.00	110.00	5.20 (kg)	349052
	D 60	350.00 - 430.00	85.00	339.00	125.00	6.90 (kg)	349053
	D 60	425.00 - 505.00	85.00	414.00	125.00	8.00 (kg)	349054

Key on B10-G: 1

B10-M: 12-13

B10-G: 23

B10-G: 16-19

B10-H

B10: VI-VII

Ⓜ = Metric (mm)

⚠ WARNING Exceeding weight capacity for machine tool spindle and tool changer can cause machine damage and/or serious injury. To prevent:

- Consult machine tool builder for machine's weight limitations.
- Refer to example on page B10-M: 11 for calculating tool assembly weight

Factory technical assistance is also available for specific applications through our Application Engineering department. *email: engineering.eu@alliedmachine.com*

⚠ WARNING Tool failure can cause serious injury. To prevent:

- Do not exceed recommended 10xD length-to-diameter ratio or exceed 4 total components (including shank)
- When using Alu-Line® components, do not exceed recommended 5xD length-to-diameter ratio
- When using tool steel components, do not exceed recommended 6xD length-to-diameter ratio
- When using heavy metal components, do not exceed recommended 8xD length-to-diameter ratio
- When using a carbide shank, do not exceed recommended 9xD length-to-diameter ratio
- When using a NOVITECH module, do not exceed recommended 10xD length-to-diameter ratio
- Refer to examples on pages B10-M: 8-10 for calculating length-to-diameter ratio

Factory technical assistance is available for your specific applications through our Application Engineering department. *email: engineering.eu@alliedmachine.com*

Alu-Line Eco D 60 Serrated Slides

Diameter Range: 465.00 mm - 1020.00 mm

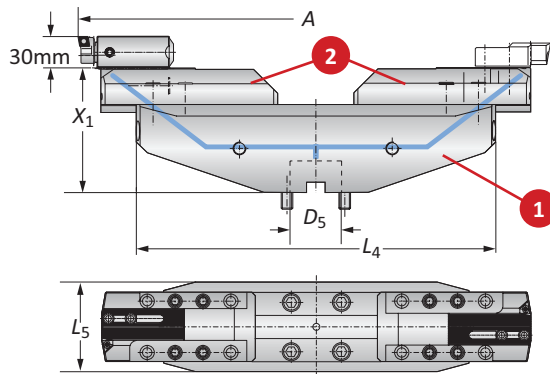

Connection	Boring Range	Serrated Slide			1 Base Slide		2 Serrated Slide (Alu-Line)*		2 Serrated Slide (steel)**		
		D_5	A	X_1	L_4	L_5	Weight	Part No.	Weight	Part No.	Weight
M	D 60	465.00 - 745.00	155.00	447.00	129.00	11.80 (kg)	349005	2.20 (kg)	349015	5.70 (kg)	349014
	D 60	740.00 - 1020.00	155.00	722.00	129.00	18.00 (kg)	349006	2.20 (kg)	349015	5.70 (kg)	349014

*Finish boring: serrated slide in Alu-Line

**Rough boring: serrated slide in steel

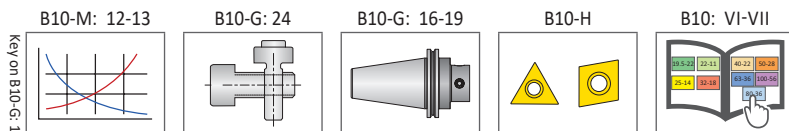

M = Metric (mm)

WARNING Exceeding weight capacity for machine tool spindle and tool changer can cause machine damage and/or serious injury. To prevent:
 -Consult machine tool builder for machine's weight limitations.
 -Refer to example on page B10-M: 11 for calculating tool assembly weight
 Factory technical assistance is also available for specific applications through our Application Engineering department. *email: engineering.eu@alliedmachine.com*

WARNING Tool failure can cause serious injury. To prevent:
 -Do not exceed recommended 10xD length-to-diameter ratio or exceed 4 total components (including shank)
 -When using Alu-Line® components, do not exceed recommended 5xD length-to-diameter ratio
 -When using tool steel components, do not exceed recommended 6xD length-to-diameter ratio
 -When using heavy metal components, do not exceed recommended 8xD length-to-diameter ratio
 -When using a carbide shank, do not exceed recommended 9xD length-to-diameter ratio
 -When using a NOVITECH module, do not exceed recommended 10xD length-to-diameter ratio
 -Refer to examples on pages B10-M: 8-10 for calculating length-to-diameter ratio
 Factory technical assistance is available for your specific applications through our Application Engineering department. *email: engineering.eu@alliedmachine.com*



Alu-Line Flex D 60 Serrated Slides

Diameter Range: 500.00 mm - 3255.00 mm

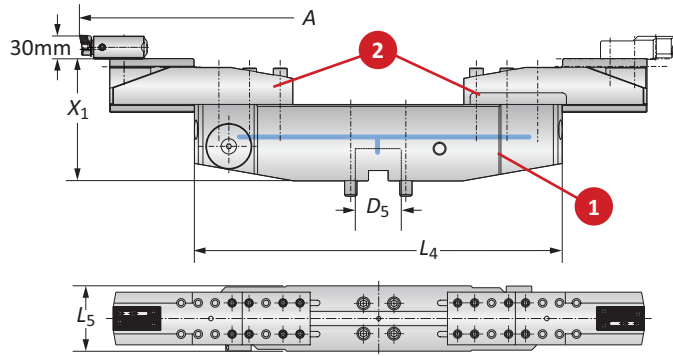

Connection	Boring Range	Serrated Slide			Weight (1 + 2)	Part No.		
		D_5	A	X_1		L_4	L_5	1 Base Slide
m	D 60	500.00 - 780.00	160.00	480.00	130.00	24.20 (kg)	349031	349035
	D 60	950.00 - 1055.00	185.00	480.00	130.00	41.30 (kg)	349031	349036
	D 60	775.00 - 1055.00	185.00	755.00	155.00	42.50 (kg)	349032	349035
	D 60	1050.00 - 1330.00	210.00	755.00	155.00	59.60 (kg)	349032	349036
	D 60	1442.00 - 1605.00	225.00	755.00	155.00	86.30 (kg)	349032	349037
	D 60	1325.00 - 1605.00	210.00	1305.00	185.00	88.20 (kg)	349033	349035
	D 60	1325.00 - 1880.00	235.00	1305.00	185.00	105.30 (kg)	349033	349036
	D 60	1600.00 - 2155.00	250.00	1305.00	185.00	132.00 (kg)	349033	349037
	D 60	1990.00 - 2430.00	255.00	1305.00	185.00	169.80 (kg)	349033	349038
	D 60	2150.00 - 2430.00	235.00	2130.00	225.00	192.50 (kg)	349034	349035
	D 60	2150.00 - 2705.00	260.00	2130.00	225.00	209.60 (kg)	349034	349036
	D 60	2150.00 - 2980.00	275.00	2130.00	225.00	236.00 (kg)	349034	349037
	D 60	2150.00 - 3255.00	280.00	2130.00	225.00	274.00 (kg)	349034	349038

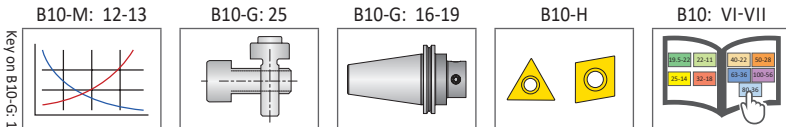

m = Metric (mm)

WARNING Exceeding weight capacity for machine tool spindle and tool changer can cause machine damage and/or serious injury. To prevent:
 -Consult machine tool builder for machine's weight limitations.
 -Refer to example on page B10-M: 11 for calculating tool assembly weight
 Factory technical assistance is also available for specific applications through our Application Engineering department. *email: engineering.eu@alliedmachine.com*

WARNING Tool failure can cause serious injury. To prevent:
 -Do not exceed recommended 10xD length-to-diameter ratio or exceed 4 total components (including shank)
 -When using Alu-Line® components, do not exceed recommended 5xD length-to-diameter ratio
 -When using tool steel components, do not exceed recommended 6xD length-to-diameter ratio
 -When using heavy metal components, do not exceed recommended 8xD length-to-diameter ratio
 -When using a carbide shank, do not exceed recommended 9xD length-to-diameter ratio
 -When using a NOVITECH module, do not exceed recommended 10xD length-to-diameter ratio
 -Refer to examples on pages B10-M: 8-10 for calculating length-to-diameter ratio
 Factory technical assistance is available for your specific applications through our Application Engineering department. *email: engineering.eu@alliedmachine.com*