

UPA Product Overview



UPA Boring Head FACING AND BORING

Universal Facing and Boring Heads

The versatile Wohlhaupter UPA boring heads can be used for facing, boring, and taper turning. They can also be used for right- or left-handed turning.

Precise and *versatile* boring heads.

- Diameter range: 0.00 mm - 620.00 mm
- Slide adjustment up to 112.00 mm
- Can be used in a variety of operations

UNIVERSAL FACING AND BORING Applications

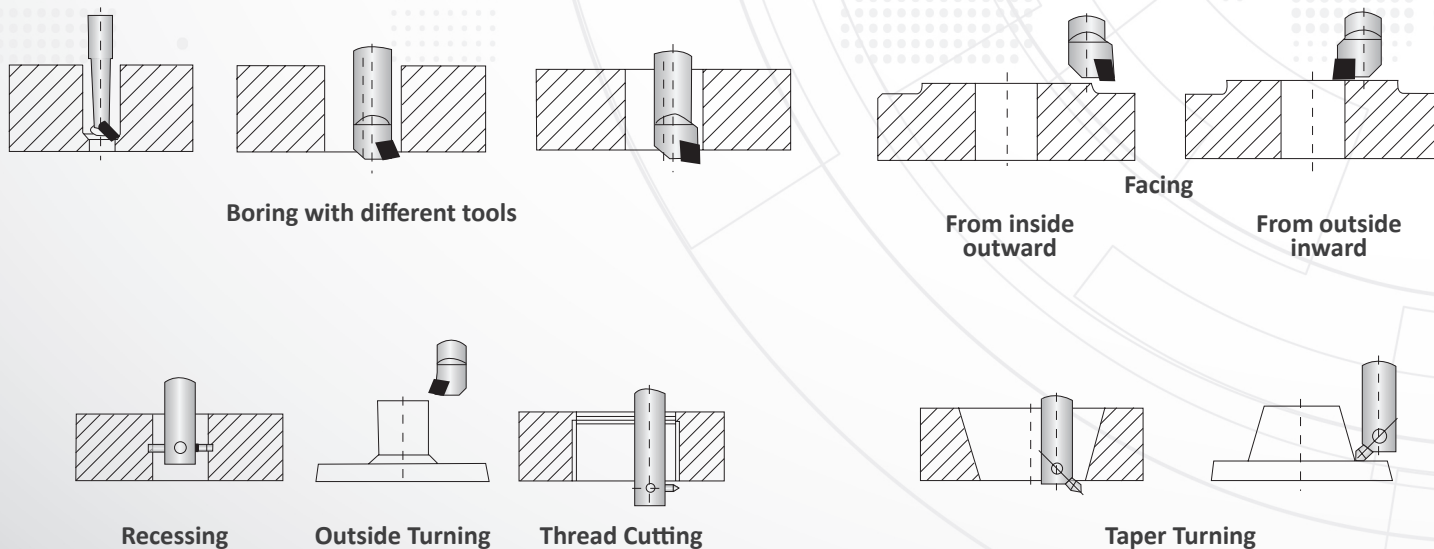

UNIVERSAL

FACING & BORING Application Examples

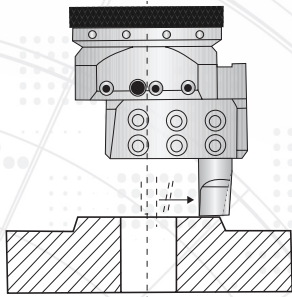

Facing with boring bar directly in slide

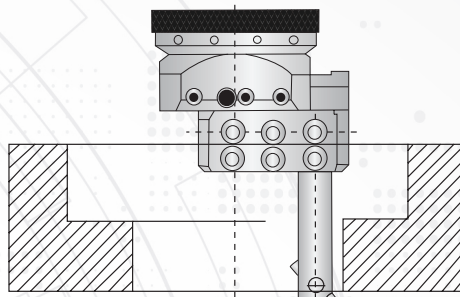

Boring with long boring bar

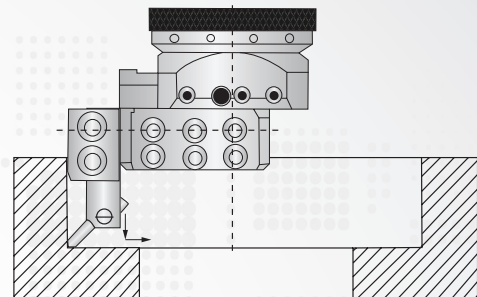

Boring and facing with short boring bar holder and a boring bar

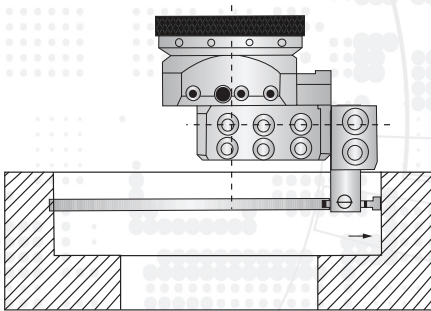

Recessing with short boring bar holder and a boring bar

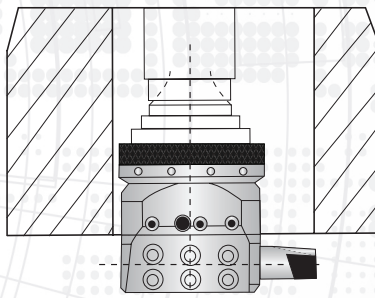

Deep hole boring with boring bar directly in slide

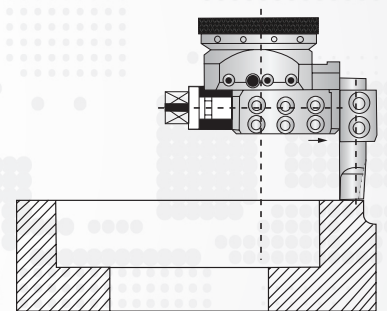

Large diameter facing with a long boring bar holder

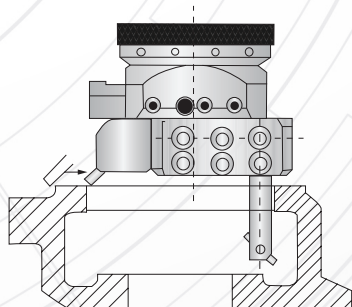

Facing in two areas with one boring bar and a boring bar holder

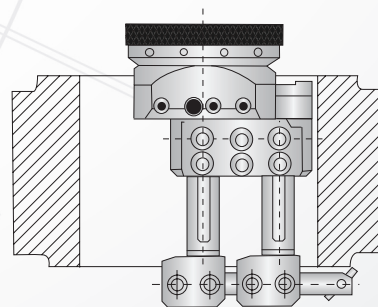

Facing the reverse side by using boring bar holders contained in attachment