

**GRAF Innendreh-Halter
für HORN-Schneidplatten Typ 105 mit Innenkühlung**

GRAF boring shank holder
for HORN inserts type 105 with coolant supply

GRAF porte-outil pour alésage
pour insert HORN type 105 avec raccord pour canal d'arrosage

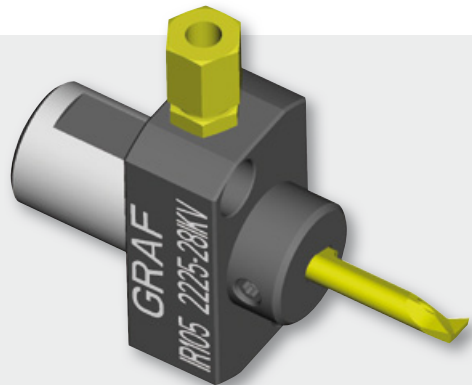

Kühlmittelanschluss
M 8x1

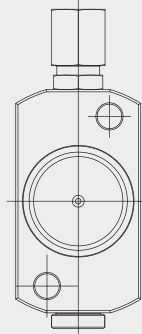
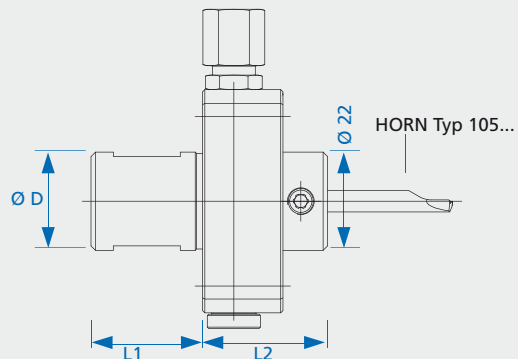

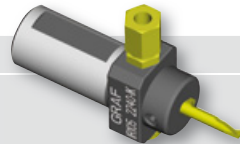
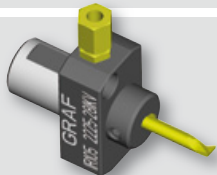
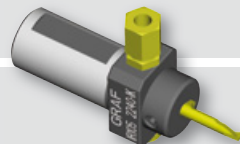
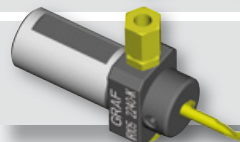
	Bestell-Nr.	Ø D	L 1	L 2
	IR 105.3440.IKV	3/4"	40	23
	IR 105.1060.IKV	1"	60	23
	IR 105.1640.IKV	16	40	23
	IR 105.2240.IKV	22	40	23
	IR 105.2225-28.IKV	22	25	28
	IR 105.2225-40.IKV	22	25	40
	IR 105.2225-60.IKV	22	25	60
	IR 105.2040.IKV	20	40	23
	IR 105.2560.IKV	25	60	23